

INSTRUCTIONS

MODEL AVO-9E-C PULSE GENERATOR

S.N.:

### WARRANTY

Avtech Electrosystems Ltd. warrants products of its manufacture to be free from defects in material and workmanship under conditions of normal use. If, within one year after delivery to the original owner, and after prepaid return by the original owner, this Avtech product is found to be defective, Avtech shall at its option repair or replace said defective item. This warranty does not apply to units which have been disassembled, modified or subjected to conditions exceeding the applicable specifications or ratings. This warranty is the extent of the obligation assumed by Avtech with respect to this product and no other warranty or guarantee is either expressed or implied.

### TECHNICAL SUPPORT

Phone: 613-226-5772 or 1-800-265-6681

Fax: 613-226-2802 or 1-800-561-1970

E-mail: [info@avtechpulse.com](mailto:info@avtechpulse.com)

World Wide Web: <http://www.avtechpulse.com>



## TABLE OF CONTENTS

WARRANTY.....	2
TABLE OF CONTENTS.....	4
FIG. 1: PULSE GENERATOR TEST ARRANGEMENT (AVX-S1 Module Disconnected).....	6
GENERAL OPERATING INSTRUCTIONS (AVX-S1 Module Disconnected).....	7
FIG. 2: PULSE GENERATOR TEST ARRANGEMENT (AVX-S1 Module Connected).....	9
CONNECTING THE AVO-9A-C TO THE AVX-S1.....	10
AVX-S1 FUNCTIONAL EQUIVALENT CCT. PACKAGE.....	11
AVX-S SERIES DATA SHEET.....	12
SPECIFICATIONS.....	13
FIG. 3: FRONT PANEL CONTROLS.....	14
FRONT PANEL CONTROLS.....	15
FIG. 4: BACK PANEL CONTROLS.....	17
BACK PANEL CONTROLS.....	18
FIG. 5: SYSTEM BLOCK DIAGRAM.....	19

POWER SUPPLY AND FUSE REPLACEMENT.....20

PERFORMANCE CHECK SHEET.....22

Manual Reference: /fileserver1/officefiles/instructword/avo-9/AVO-9E-Cedb-fig.doc, created September 15, 2000

FIG. 1: PULSE GENERATOR TEST ARRANGEMENT  
(AVX-S1 Module Disconnected)

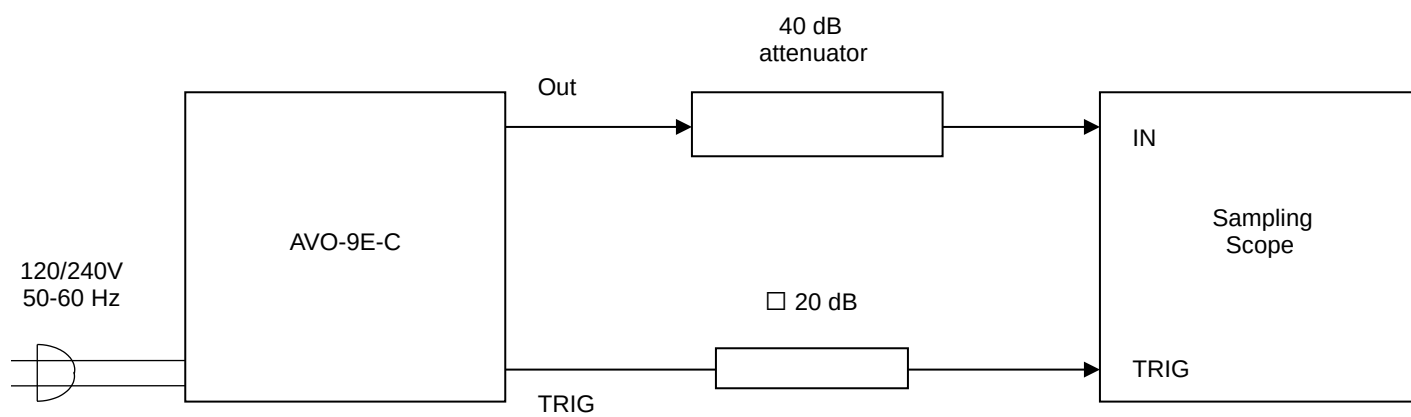

GENERAL OPERATING INSTRUCTIONS  
(AVX-S1 Module Disconnected)

- 1) The bandwidth capability of components and instruments used to display the pulse generator output signal (attenuators, cables, connectors, etc.) should exceed one gigahertz.
- 2) The use of 40 db attenuator at the sampling scope vertical input channel will insure a peak input signal to the sampling scope of less than one volt.
- 3) The TRIG output channel provides a +0.5 V, 20 ns wide pulse. To avoid overdriving the TRIG input channel of some sampling scopes, a 20 db attenuator should be placed at the input to the sampling scope trigger channel.
- 4) To obtain a stable output display the PRF and PRF FINE controls on the front panel should be set mid-range while the PRF range switch may be in either range. The front panel TRIG toggle switch should be in the INT position. The front panel DELAY control and the scope triggering controls are then adjusted to obtain a stable output. It is recommended that the DELAY control first be set max counter clockwise and then turned clockwise until a stable display is obtained. The scope may then be used to set the desired PRF by rotating the PRF and PRF FINE controls and by means of the PRF range switch.
- 5) The output pulse width is controlled by means of the front panel one turn PW control. The control should initially be set maximum counter clockwise and the pulse width adjusted using an oscilloscope.
- 6) The output pulse amplitude is controlled by means of the front panel one turn AMP control.
- 7) An external clock may be used to control the output PRF of the AVO-9E unit by setting the front panel TRIG toggle switch in the EXT position and applying a 50 nsec, or under, TTL level pulse to the TRIG BNC connector input.
- 8) **WARNING:** Model AVO-9E-C may fail if triggered at a PRF greater than 10.0 MHz or at a duty cycle exceeding 20%.
- 9) AVO-9E-C units with a serial number higher than 5600 are protected by an automatic overload protective circuit which controls the front panel overload light. If the unit is overloaded (by operating at an exceedingly high duty cycle or by operating into a short circuit), the protective circuit will turn the output of the instrument OFF and turn the indicator light ON. The light will stay ON (i.e. output OFF) for about 5 seconds after which the instrument will attempt to turn ON (i.e. light OFF) for about 1 second. If the overload condition persists, the

instrument will turn OFF again (i.e. light ON) for another 5 seconds. If the overload condition has been removed, the instrument will turn on and resume normal operation. Overload conditions may be removed by:

- 1) Reducing PRF (i.e. switch to a lower range)
- 2) Reducing pulse width (i.e. switch to a lower range).

10) Dual Polarity Option. To invert the output of the AVO- 9E unit, connect the IN PORT of the AVX-3 unit to the OUT port of the AVO-9E mainframe. An inverted pulse is then obtained at the OUT port of the AVX-3 unit.

11) The rise and fall time are switched from the high to low range by means of the TR and TF two position switches. (TRF option).

12) The AVO-9E-C unit can be converted from 120 to 240V 50- 60 Hz operation by adjusting the voltage selector card in the rear panel fused voltage selector-cable connector assembly.

13) For additional assistance:

Tel: (613) 226-5772

Fax: (613) 226-2802

Email: [info@avtechpulse.com](mailto:info@avtechpulse.com)



**FIG. 2: PULSE GENERATOR TEST ARRANGEMENT**  
(AVX-S1 Module Connected)

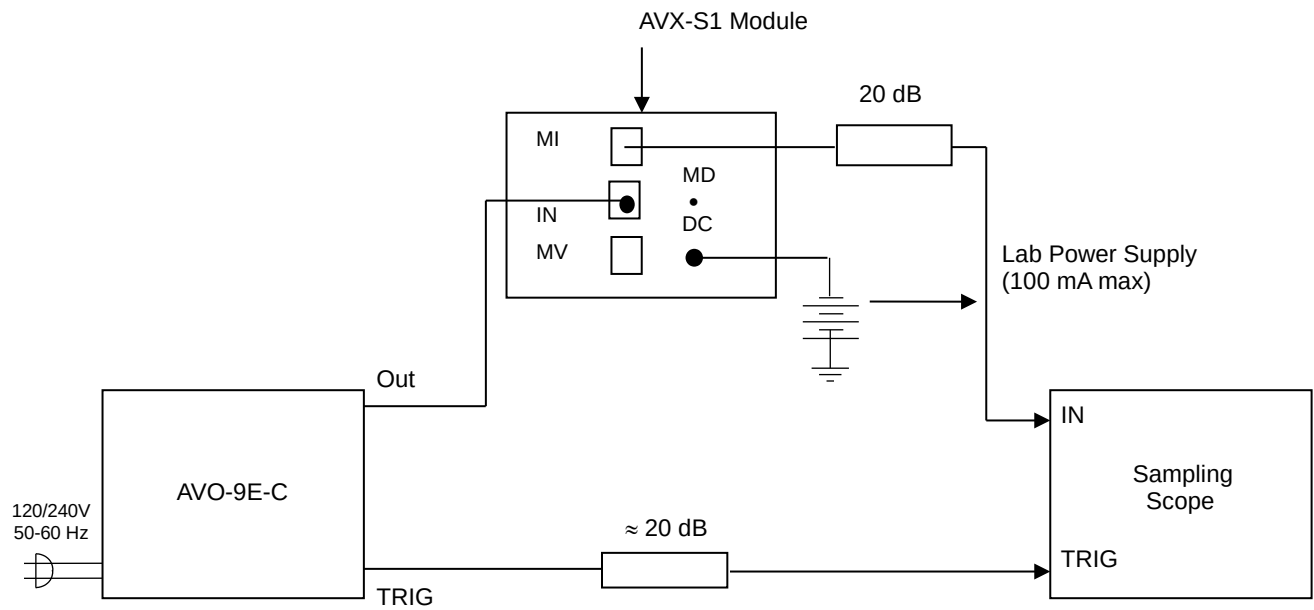

### CONNECTING THE AVO-9A-C TO THE AVX-S1

- 1) A general description of the AVX-S1 module is given in the enclosed data sheet.
- 2) The AVX-S1 module should be connected to the AVO-9A-C mainframe via the supplied 24" RG174 cable. The diode current may be monitored by connecting the MI and MV output ports to the sampling scope via 20 dB attenuators. The output amplitude ( $V_{MI}$  and  $V_{MV}$ , and Volts) and diode current ( $I_D$ , Amp) are related as follows:

$$I_D = 0.2 (V_{MI} - V_{MV})$$

The laser diode voltage is given by the following:

$$V_D = 10 V_{MV}$$

- 3) The laser diode plugs directly into the socket on the side of the AVX-S1 module.
- 4) A forward DC bias may be applied to the laser diode by connecting a DC potential of 0 to -5 Volts to the DC solder terminal. The application of a small forward bias often yields a more ideal diode current waveform (as observed on the MI port). Note that the DC port must be shorted to ground if a bias is not applied.

AVX-S1 FUNCTIONAL EQUIVALENT CCT. PACKAGE

AVX-S SERIES DATA SHEET

SPECIFICATIONS

FIG. 3: FRONT PANEL CONTROLS

## FRONT PANEL CONTROLS

- (1) ON-OFF Switch. Applies basic prime power to all stages.
- (2) PRF Control. PRF RANGE, PRF and PRF FINE controls determine output PRF as follows:

	PRF MIN	PRF MAX
Range 1	100 Hz	1 KHz
Range 2	1 KHz	10 KHz
Range 3	10 KHz	100 KHz
Range 4	100 KHz	1.0 MHz
Range 5	1.0 MHz	10 MHz

- (3) DELAY Control. Controls the relative delay between the reference output pulse provided at the TRIG output (4) and the main output (7). This delay is variable over the range of 0 to at least 100 nsec.
- (4) TRIG Output. This output precedes the main output (7) and is used to trigger the sampling scope time base. The output is a +0.5V 20 ns (approx) pulse capable of driving a fifty-ohm load.
- (5) PW Control. A one-turn control which varies the output pulse width.
- (6) AMP Control. A one-turn control which varies the output pulse amplitude from 0 to max output to a fifty-ohm load.
- (7) OUT Connector. SMA connector provides output to a fifty-ohm load.
- (8) EXT-INT Control. With this toggle switch in the INT position, the PRF of the AVO-9E unit is controlled via an internal clock which in turn is controlled by the PRF controls. With the toggle switch in the EXT position, the AVO-9E unit requires a 10 ns (or under) TTL level pulse applied at the TRIG input in order to trigger the output stages. In addition, in this mode, the scope time base must be triggered by the external trigger source.
- (9) AVO-9E-C units with a serial number higher than 5600 are protected by an automatic overload protective circuit which controls the front panel overload light. If the unit is overloaded (by operating at an exceedingly high duty cycle or by operating into a short circuit), the protective circuit will turn the output of the instrument OFF and turn the indicator light ON. The light will stay ON (i.e. output

OFF) for about 5 seconds after which the instrument will attempt to turn ON (i.e. light OFF) for about 1 second. If the overload condition persists, the instrument will turn OFF again (i.e. light ON) for another 5 seconds. If the overload condition has been removed, the instrument will turn on and resume normal operation. Overload conditions may be removed by:

- 1) Reducing PRF (i.e. switch to a lower range)
- 2) Reducing pulse width (i.e. switch to a lower range)
- 3) Removing output load short circuit (if any)

Note that the overload light may illuminate when the prime power is first applied. The light will extinguish after a few seconds and the instrument will then function normally.



FIG. 4: BACK PANEL CONTROLS

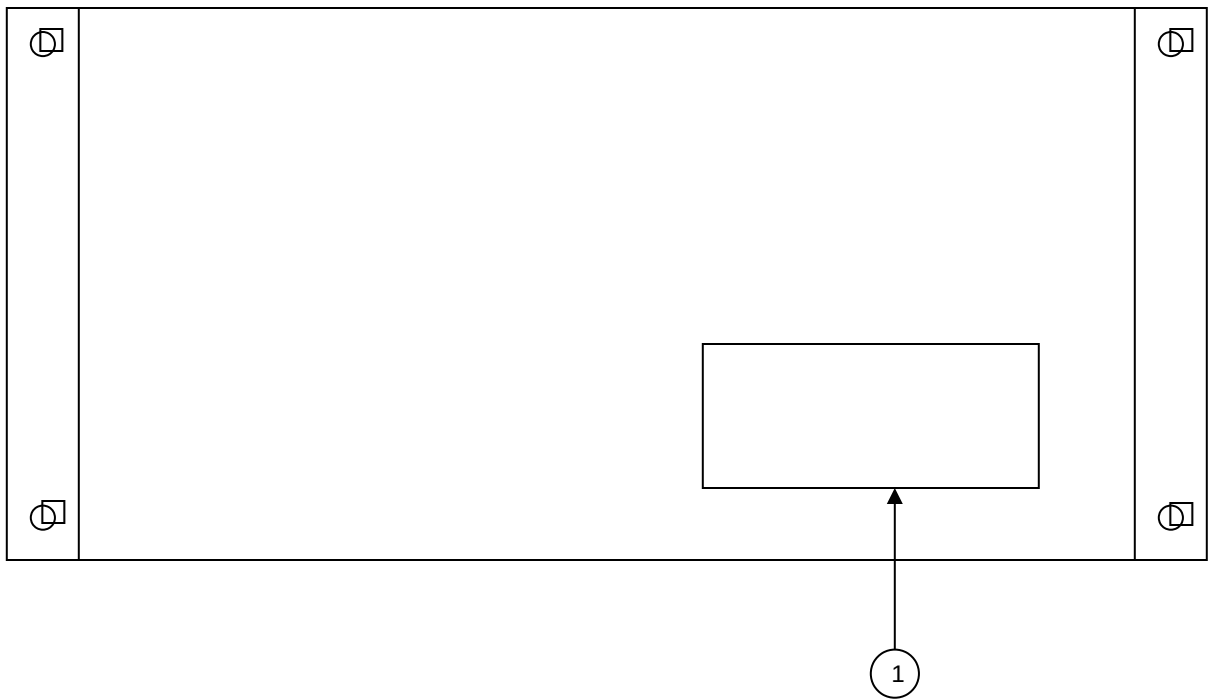

### BACK PANEL CONTROLS

- (1) FUSED CONNECTOR, VOLTAGE SELECTOR. The detachable power cord is connected at this point. In addition, the removable cord is adjusted to select the desired input operating voltage. The unit also contains the main power fuse (0.25 A SB).

FIG. 5: SYSTEM BLOCK DIAGRAM

## POWER SUPPLY AND FUSE REPLACEMENT

This instrument has three fuses (plus one spare). One, which protects the AC input, is located in the rear-panel power entry module, as described in the “Rear Panel Controls” section of this manual. If the power appears to have failed, check the AC fuse first.

The other two fuses (plus one spare) are located on the internal DC power supply, as shown below:

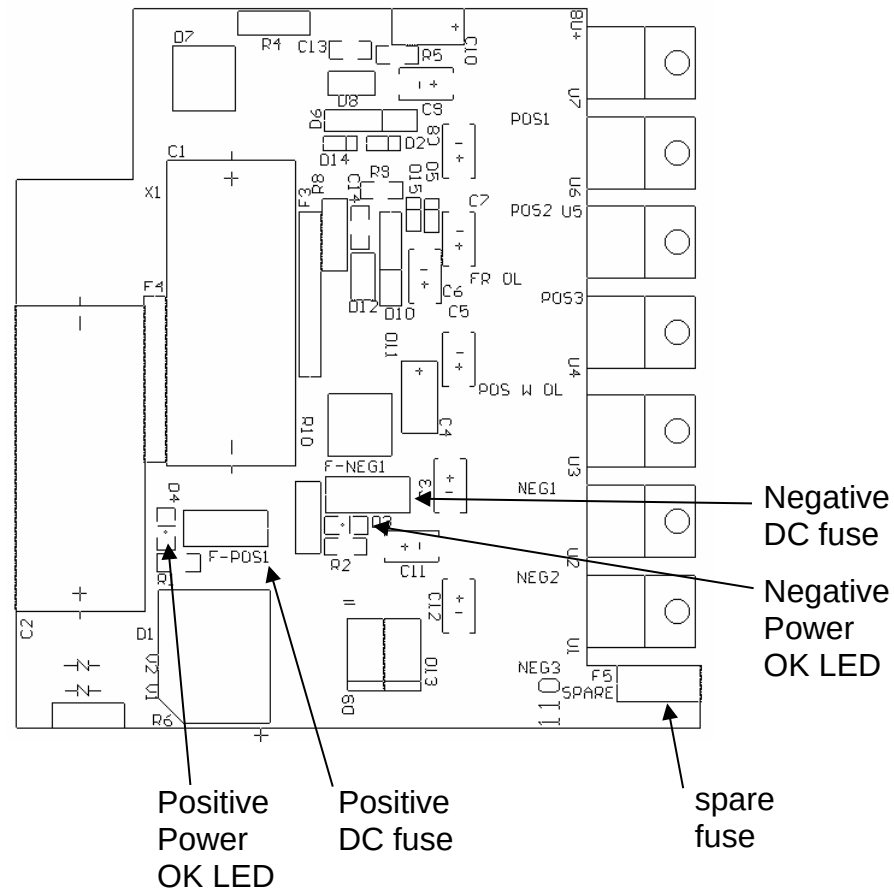

The positive fuse and the spare fuse on this circuit board are 1A slow-blow fuses, Littlefuse part number R452001. (This fuse can be ordered from Digikey, [www.digikey.com](http://www.digikey.com). The Digikey part number is F1343CT-ND). The negative fuse is a 0.5A slow-blow fuse (Littlefuse R452.500, Digikey part number F1341CT-ND).

If you suspect that the DC fuses are blown, follow this procedure:

1. Remove the top cover, by removing the four Phillips screws on the top cover and then sliding the cover back and off.

2. Locate the two “Power OK” LEDs on the power supply circuit board, as illustrated above.
3. Turn on the instrument.
4. Observe the “Power OK” LEDs. If the fuses are not blown, the two LEDs will be lit (bright red). If one of the LEDs is not lit, the fuse next to it has blown.
5. Turn off the instrument.
6. If a fuse is blown, use needle-nose pliers to remove the blown fuse from its surface-mount holder.
7. Replace the fuse.

PERFORMANCE CHECK SHEET