



AVTECH ELECTROSYSTEMS LTD.

NANOSECOND WAVEFORM ELECTRONICS
SINCE 1975

P.O. BOX 265
OGDENSBURG, NY
U.S.A. 13669-0265

TEL: 888-670-8729 (USA & Canada) or +1-613-686-6675 (Intl)
FAX: 800-561-1970 (USA & Canada) or +1-613-686-6679 (Intl)

info@avtechpulse.com - <http://www.avtechpulse.com/>

BOX 5120, LCD MERIVALE
OTTAWA, ONTARIO
CANADA K2C 3H4

INSTRUCTIONS

MODEL AVO-9F2-C-AK1-QTKB-N-AC22
0 TO 340 mA, 200 ps RISE TIME
HIGH PERFORMANCE LASER DIODE DRIVER
WITH PLUG-IN SOCKET OUTPUT MODULE

AVX-S1-QTKB

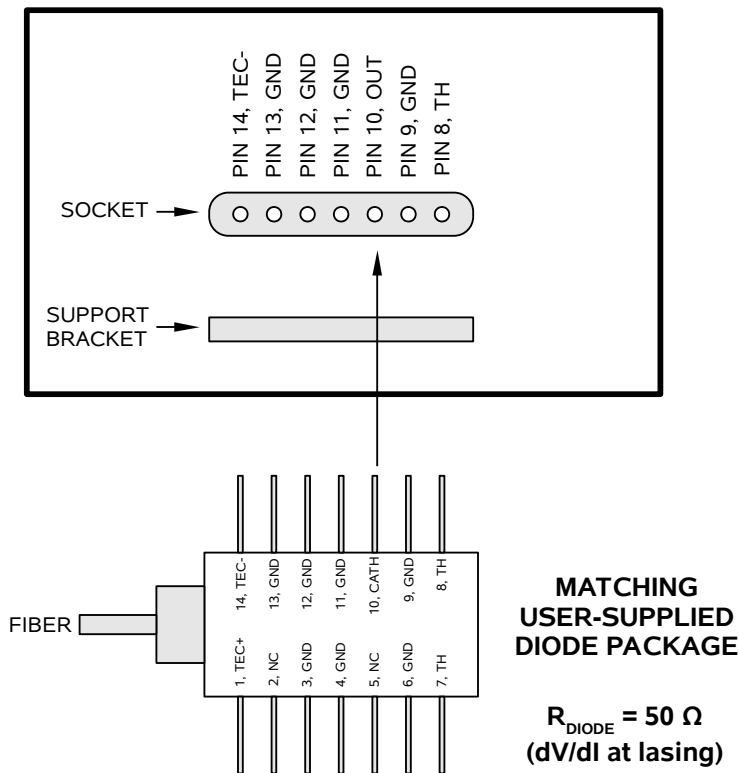

SERIAL NUMBER: _____

WARRANTY

Avtech Electrosystems Ltd. warrants products of its manufacture to be free from defects in material and workmanship under conditions of normal use. If, within one year after delivery to the original owner, and after prepaid return by the original owner, this Avtech product is found to be defective, Avtech shall at its option repair or replace said defective item. This warranty does not apply to units which have been disassembled, modified or subjected to conditions exceeding the applicable specifications or ratings. This warranty is the extent of the obligation assumed by Avtech with respect to this product and no other warranty or guarantee is either expressed or implied.

TECHNICAL SUPPORT

Phone: 888-670-8729 (USA & Canada) or +1-613-686-6675 (International)

Fax: 800-561-1970 (USA & Canada) or +1-613-686-6679 (International)

E-mail: info@avtechpulse.com

World Wide Web: <http://www.avtechpulse.com>

TABLE OF CONTENTS

WARRANTY.....	2
TECHNICAL SUPPORT.....	2
TABLE OF CONTENTS.....	3
INTRODUCTION.....	5
SPECIFICATIONS.....	7
ORIGINAL QUOTATION.....	8
REGULATORY NOTES.....	10
FCC PART 18.....	10
EC DECLARATION OF CONFORMITY.....	10
DIRECTIVE 2002/95/EC (RoHS).....	11
DIRECTIVE 2002/96/EC (WEEE).....	11
AC POWER SUPPLY REGULATORY NOTES.....	12
INSTALLATION.....	13
VISUAL CHECK.....	13
POWER RATINGS.....	13
CONNECTION TO THE POWER SUPPLY.....	13
PROTECTION FROM ELECTRIC SHOCK.....	14
ENVIRONMENTAL CONDITIONS.....	15
FUSES.....	16
AC FUSE REPLACEMENT.....	16
DC FUSE REPLACEMENT.....	17
FUSE RATINGS.....	17
FRONT PANEL CONTROLS.....	18
REAR PANEL CONTROLS.....	20
GENERAL INFORMATION.....	21
MINIMAL TEST ARRANGEMENT - WITHOUT OUTPUT MODULE.....	21
NORMAL TEST ARRANGEMENT.....	21
THERMAL CONTROL.....	24
AMPLITUDE CONTROL.....	24
PULSE WIDTH CONTROL.....	24
PULSE WIDTH / AMPLITUDE INTERACTION.....	25
THERMAL / OVERLOAD ALARMS.....	26
PROTECTING YOUR INSTRUMENT.....	27

DO NOT EXCEED 100 MHz.....	27
DO NOT GO BELOW 25 MHz.....	27
KEEP THE AMPLITUDE BELOW 20V.....	27
USE A 50Ω LOAD.....	27
INSTALL THE DIODE CORRECTLY.....	27
MECHANICAL INFORMATION.....	28
TOP COVER REMOVAL.....	28
RACK MOUNTING.....	28
ELECTROMAGNETIC INTERFERENCE.....	28
MAINTENANCE.....	29
REGULAR MAINTENANCE.....	29
CLEANING.....	29
WIRING DIAGRAMS.....	30
WIRING OF AC POWER.....	30
PCB 158N - LOW VOLTAGE POWER SUPPLY, 1/3.....	31
PCB 158N - LOW VOLTAGE POWER SUPPLY, 2/3.....	32
PCB 158N - LOW VOLTAGE POWER SUPPLY, 3/3.....	33
PCB 94F – ALARM BOARD.....	34
PCB 216A - PRF/PW TWEAKING PCB.....	35
.....	35
MAIN WIRING.....	36
PERFORMANCE CHECKSHEET.....	37

INTRODUCTION

The AVO-9F2-C-AK1-QTKB-N-AC22 is a high performance instrument capable of generating up to 340 mA into diode loads, at repetition rates between 25 and 100 MHz.

The AVO-9F2-C-AK1-QTKB-N-AC22 consists of a mainframe unit and an AVX-S1 series output module, which provides a socket into which the user's laser diode may be inserted. The mainframe generates voltage pulses of between 0 and -20V. The output module connects to the instrument mainframe via a detachable 2 foot long coaxial cable. The output module contains the necessary elements to match the laser diode to the pulse generator mainframe. The output module contains the necessary elements to match the laser diode to the pulse generator mainframe. A DC bias current of 0 to -100 mA may be applied to the laser diode by applying the desired DC current to a solder terminal on the output module. The output modules include an SMA output connector that provides an attenuated coincident replica of the diode current.

The AVX-S1 output module supplied with the AVO-9F2-C-AK1-QTKB-N-AC22 is specifically designed to accommodate custom diodes with the pinout illustrated below. The diode should have a resistance (dV/dI at lasing) of 50 Ohms for proper impedance matching.

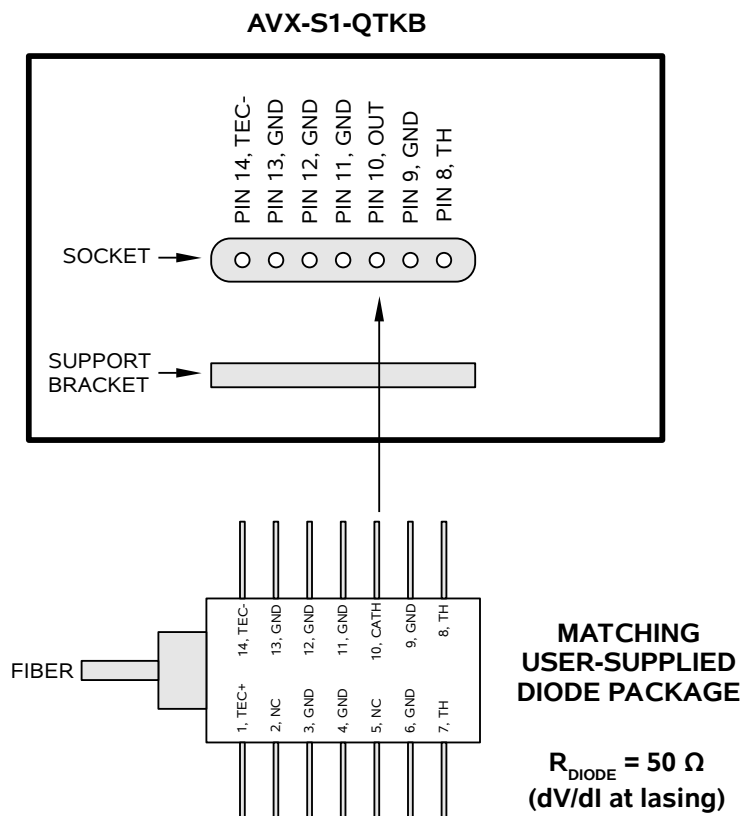

The instrument contains thermal sensors to detect overheating of the output stage. If the output stage becomes too hot, an alarm will sound and the output triggering will stop until the temperature has decreased sufficiently.

SPECIFICATIONS

Model:	AVO-9F2-C-AK1-QTKB-N-AC22
Amplitude, standard ¹ :	Up to -20V into a total resistance (diode resistance + output module resistance) of 50 Ohms. This means that if your diode voltage is 3V, then you can obtain up to $(20V - 3V) / 50 \text{ Ohms} = 340 \text{ mA}$ of current, approximately.
Max. output of mainframe into 50Ω ($V_{\text{MAINFRAME}}$):	-20V
$R_S + R_{\text{DIODE}}$:	50Ω
Allowed load voltage range:	0 to 3V. (Contact Avtech if your diode has a higher forward voltage drop)
Pulse width (FWHM):	0.4 - 1 ns
Duty cycle limits:	N/A
Minimum PRF:	25 MHz
Maximum PRF:	100 MHz
Rise / fall times (20%-80%):	≤ 200 ps
Related 50Ω series:	AVN-4
Included output module:	AVX-S1
Polarity:	Negative
Propagation delay:	≤ 100 ns
Jitter:	± 15 ps (Ext trig in to pulse out)
DC offset or bias insertion:	Apply required DC bias current in the range of ± 100 mA to solder terminal on output module.
Sync output (to 50Ω):	400 mV square wave
Trigger required: (ext trig mode)	ECL-level (LOW = -1.6V, HIGH = -0.8V) square wave (50% duty cycle). Terminated by 50 Ohms to -2V internally.
Recommended accessory kit:	Add the suffix "-AK1" to the model number to include the recommended accessory kit. Consists of three SMA, 18 GHz, 2 Watt attenuators (10, 20 & 30 dB) for use on the output, and two 50 Ohm, 1 GHz, 1 Watt feed-through terminators (one SMA, one BNC) for use on external trigger inputs.
Power requirements:	100 - 240 Volts, 50 - 60 Hz
Dimensions, Mainframe: (H×W×D)	100 x 430 x 375 mm (3.9" x 17" x 14.8") .
Dimensions, Output Module:	41 x 66 x 76 mm (1.6" x 2.6" x 3.0"), cast aluminum, blue enamel
Temperature range:	+5°C to +40°C

1) For operation at amplitudes of less than 20% of full-scale, best results will be obtained by setting the amplitude near full-scale and using external attenuators on the output, between the mainframe and the output module. Attenuators are available in the -AK1 accessory kit option.

ORIGINAL QUOTATION

Quote number: 15896.01

Model number: AV0-9F2-C-AK1-QTKB-N-AC22

Description: Laser Diode Driver (Pulsed Voltage)

-QTKB-N special socket arrangement: A negative pulse will be applied to the diode cathode (pin 10). Pins 3, 4, 6, 9, and 11-13 will be grounded. A male DB-9 connector is provided on the output module, which provides access to the thermal control pins of the diode, as follows:

- DB-9 pin 2 connects to diode pin 7 (TH)
- DB-9 pin 3 connects to diode pin 8 (TH)
- DB-9 pin 4 connects to diode pin 1 (TEC+)
- DB-9 pin 5 connects to diode pin 14 (TEC-).
- DB-9 pin 6 connects to diode pin 2 (future use)
- DB-9 pin 7 connects to diode pin 5 (future use)

The remaining DB-9 pins are unconnected.

Four mounting holes on a 8.9 x 26 mm grid will be provided. The diode parasitic resistance (dV/dI at lasing) must be approximately 50 Ohms. The output module will not contain any internal series resistance.

-AK1 accessory kit: Consists of three SMA, 18 GHz, 2 Watt attenuators (10, 20 & 30 dB) and two 50 Ohm, 1 GHz, 1 Watt feed-through terminators (one SMA, one BNC). The attenuators may be used to reduce the output amplitude of the pulser.

Pricing, manuals, datasheets: <http://www.avtechpulse.com/laser/avo-9f2>

PDF datasheet:

http://www.avtechpulse.com/catalog/page064_cat11_avo-9_rev31.pdf

Price: \$X US each, Ex-works, Ottawa, Canada. Before discount.

Quote valid for: 8 weeks

Note: Orders with Avtech are non-cancelable, non-refundable. Avtech does not offer returns, due to the highly-specialized low-volume nature of our instruments.

Estimated delivery: 8 weeks after receipt of order (excluding export permit* delays).

*Export Permit: These instruments are very high performance pulse generators, which are considered to be "Nuclear-Related Dual-Use Goods" under government regulations. As such, an "End Use Statement - High Speed Models" form must be completed when ordering. The necessary form is attached (in PDF format), and is also available at <http://www.avtechpulse.com/end-use/EndUseStatement,HighSpeed,v8.pdf>. We will use the information in the completed form to apply for an export license from the Canadian government, which will take 1 to 6 weeks to

obtain. We cannot ship your order without the license. Please return the completed form to us by fax or email.

REGULATORY NOTES

FCC PART 18

This device complies with part 18 of the FCC rules for non-consumer industrial, scientific and medical (ISM) equipment.

This instrument is enclosed in a rugged metal chassis and uses a filtered power entry module (where applicable). The main output signal is provided on a shielded connector that is intended to be used with shielded coaxial cabling and a shielded load. Under these conditions, the interference potential of this instrument is low.

If interference is observed, check that appropriate well-shielded cabling is used on the output connectors. Contact Avtech (info@avtechpulse.com) for advice if you are unsure of the most appropriate cabling. Also, check that your load is adequately shielded. It may be necessary to enclose the load in a metal enclosure.

If any of the connectors on the instrument are unused, they should be covered with shielded metal "dust caps" to reduce the interference potential.

This instrument does not normally require regular maintenance to minimize interference potential. However, if loose hardware or connectors are noted, they should be tightened. Contact Avtech (info@avtechpulse.com) if you require assistance.

EC DECLARATION OF CONFORMITY



We Avtech Electrosystems Ltd.
 P.O. Box 5120, LCD Merivale
 Ottawa, Ontario
 Canada K2C 3H4

declare that this pulse generator meets the intent of Directive 2004/108/EG for Electromagnetic Compatibility. Compliance pertains to the following specifications as listed in the official Journal of the European Communities:

EN 50081-1 Emission

EN 50082-1 Immunity

and that this pulse generator meets the intent of the Low Voltage Directive 72/23/EEC as amended by 93/68/EEC. Compliance pertains to the following specifications as listed in the official Journal of the European Communities:

EN 61010-1:2001 Safety requirements for electrical equipment for measurement, control, and laboratory use

DIRECTIVE 2002/95/EC (RoHS)

This instrument is exempt from Directive 2002/95/EC of the European Parliament and of the Council of 27 January 2003 on the Restriction of the use of certain Hazardous Substances (RoHS) in electrical and electronic equipment. Specifically, Avtech instruments are considered "Monitoring and control instruments" (Category 9) as defined in Annex 1A of Directive 2002/96/EC. The Directive 2002/95/EC only applies to Directive 2002/96/EC categories 1-7 and 10, as stated in the "Article 2 - Scope" section of Directive 2002/95/EC.

DIRECTIVE 2002/96/EC (WEEE)

European customers who have purchased this equipment directly from Avtech will have completed a "WEEE Responsibility Agreement" form, accepting responsibility for WEEE compliance (as mandated in Directive 2002/96/EC of the European Union and local laws) on behalf of the customer, as provided for under Article 9 of Directive 2002/96/EC.

Customers who have purchased Avtech equipment through local representatives should consult with the representative to determine who has responsibility for WEEE compliance. Normally, such responsibilities will lie with the representative, unless other arrangements (under Article 9) have been made.

Requirements for WEEE compliance may include registration of products with local governments, reporting of recycling activities to local governments, and financing of recycling activities.



AC POWER SUPPLY REGULATORY NOTES

This instrument converts the AC input power to the +24V DC voltage that powers the internal circuitry of this instrument using a Tamura AAD130SD-60-A switching power supply. According to the manufacturer, the Tamura AAD130SD-60-A has the following certifications:

UL60950-1
IEC60950 -1
CSA C22.2 No. 60950- 1
EN60950 -1

and is compliant with:

EN61000-3-2
EN61000-4-2 Level 2
EN61000-4-2 Level 3 (Air Only)
EN61000-4-4 Level 3
EN61000-4-5 Level 3
EN61000-4-11
CISPR 11 and 22 FCC Part 15 Class B (conducted)

INSTALLATION

VISUAL CHECK

After unpacking the instrument mainframe and the transformer module, examine to ensure that they have not been damaged in shipment. Visually inspect all connectors, knobs, and handles. Confirm that a power cord and an instrumentation manual (this manual), are with the instrument. If the instrument has been damaged, file a claim immediately with the company that transported the instrument.

POWER RATINGS

This instrument is intended to operate from 100 - 240 V, 50 - 60 Hz.

The maximum power consumption is 90 Watts. Please see the “FUSES” section for information about the appropriate AC and DC fuses.

This instrument is an “Installation Category II” instrument, intended for operation from a normal single-phase supply.

CONNECTION TO THE POWER SUPPLY

An IEC-320 three-pronged recessed male socket is provided on the back panel for AC power connection to the instrument. One end of the detachable power cord that is supplied with the instrument plugs into this socket. The other end of the detachable power cord plugs into the local mains supply. Use only the cable supplied with the instrument. The mains supply must be earthed, and the cord used to connect the instrument to the mains supply must provide an earth connection. (The supplied cord does this.)

 Warning: Failure to use a grounded outlet may result in injury or death due to electric shock. This product uses a power cord with a ground connection. It must be connected to a properly grounded outlet. The instrument chassis is connected to the ground wire in the power cord.

The table below describes the power cord that is normally supplied with this instrument, depending on the destination region:

Destination Region	Description	Option	Manufacturer	Part Number
United Kingdom, Hong Kong, Singapore, Malaysia	BS 1363, 230V, 50 Hz	-AC00	Qualtek	370001-E01
Australia, New Zealand	AS 3112:2000, 230-240V, 50 Hz	-AC01	Qualtek	374003-A01
Continental Europe, Korea, Indonesia, Russia	European CEE 7/7 "Schuko" 230V, 50 Hz	-AC02	Qualtek	364002-D01
North America, Taiwan	NEMA 5-15, 120V, 60 Hz	-AC03	Qualtek	312007-01
Switzerland	SEV 1011, 230V, 50 Hz	-AC06	Qualtek	378001-E01
South Africa, India	SABS 164-1, 220-250V, 50 Hz	-AC17	Volex	2131H 10 C3
Japan	JIS 8303, 100V, 50-60 Hz	-AC18	Qualtek	397002-01
Israel	SI 32, 220V, 50 Hz	-AC19	Qualtek	398001-01
China	GB 1002-1, 220V, 50 Hz	-AC22	Volex	2137H 10 C3

PROTECTION FROM ELECTRIC SHOCK

 Operators of this instrument must be protected from electric shock at all times. The owner must ensure that operators are prevented access and/or are insulated from every connection point. In some cases, connections must be exposed to potential human contact. Operators must be trained to protect themselves from the risk of electric shock. This instrument is intended for use by qualified personnel who recognize shock hazards and are familiar with safety precautions required to avoid possibly injury. In particular, operators should:

1. Keep exposed high-voltage wiring to an absolute minimum.
2. Wherever possible, use shielded connectors and cabling.
3. Connect and disconnect loads and cables only when the instrument is turned off.
4. Keep in mind that all cables, connectors, oscilloscope probes, and loads must have an appropriate voltage rating.
5. Do not attempt any repairs on the instrument, beyond the fuse replacement procedures described in this manual. Contact Avtech technical support (see page 2 for contact information) if the instrument requires servicing. Service is to be performed solely by qualified service personnel.

ENVIRONMENTAL CONDITIONS

This instrument is intended for use under the following conditions:

1. indoor use;
2. altitude up to 2 000 m;
3. temperature 5 °C to 40 °C;
4. maximum relative humidity 80 % for temperatures up to 31 °C decreasing linearly to 50 % relative humidity at 40 °C;
5. Mains supply voltage fluctuations up to ± 10 % of the nominal voltage;
6. no pollution or only dry, non-conductive pollution.

FUSES

This instrument contains four fuses. All are accessible from the rear-panel. Two protect the AC prime power input, and two protect the internal DC power supplies. The locations of the fuses on the rear panel are shown in the figure below:

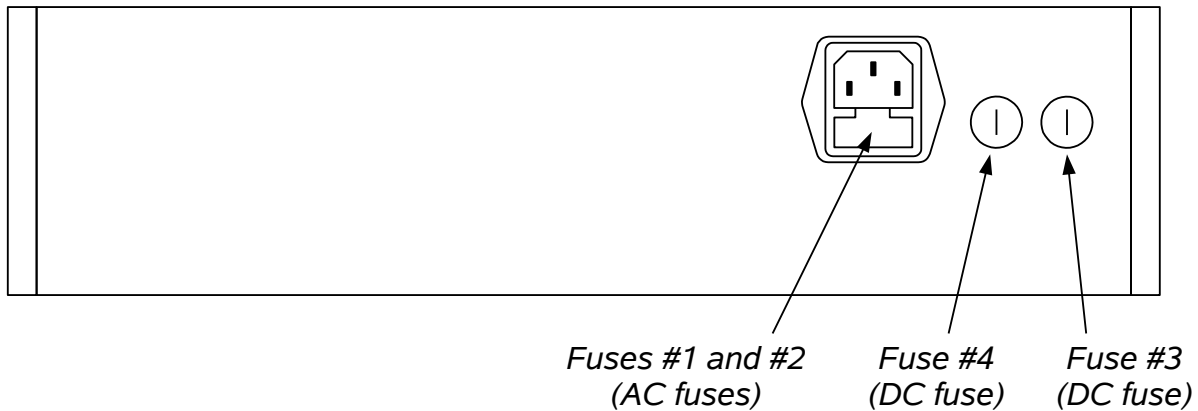

AC FUSE REPLACEMENT

To physically access the AC fuses, the power cord must be detached from the rear panel of the instrument. The fuse drawer may then be extracted using a small flat-head screwdriver, as shown below:

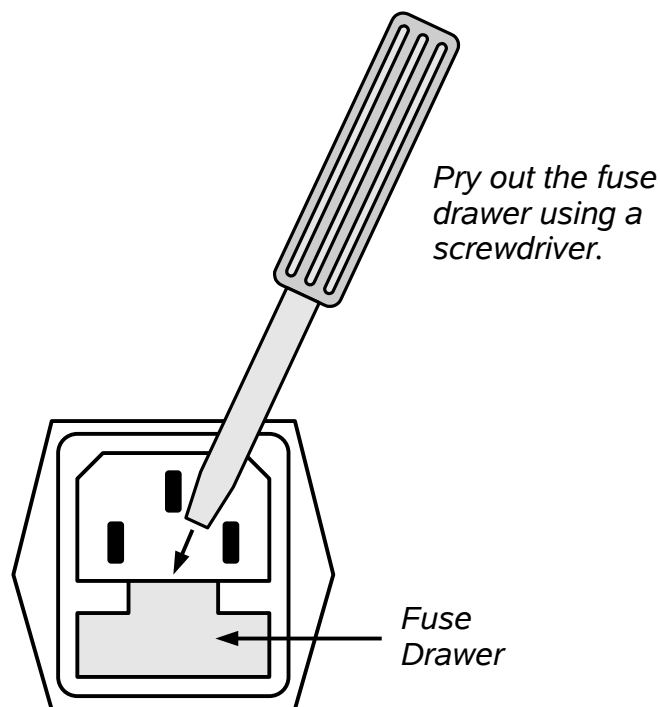

DC FUSE REPLACEMENT

The DC fuses may be replaced by inserting the tip of a flat-head screwdriver into the fuse holder slot, and rotating the slot counter-clockwise. The fuse and its carrier will then pop out.

FUSE RATINGS

The following table lists the required fuses:

Fuses	Nominal Mains Voltage	Rating	Case Size	Recommended Replacement Part	
				Littelfuse Part Number	Digi-Key Stock Number
#1, #2 (AC)	115 V	0.8A, 250V, Time-Delay	5×20 mm	0218.800HXP	F2418-ND
	230 V	0.5A, 250V, Time-Delay	5×20 mm	0218.500HXP	F2416-ND
#3 (DC)	N/A	2.5A, 250V, Time-Delay	5×20 mm	021802.5HXP	F2427-ND
#4 (DC)	N/A	2.0A, 250V, Time-Delay	5×20 mm	0218002.HXP	F2420-ND

The recommended fuse manufacturer is Littelfuse (<http://www.littelfuse.com>).

Replacement fuses may be easily obtained from Digi-Key (<http://www.digikey.com>) and other distributors.

FRONT PANEL CONTROLS

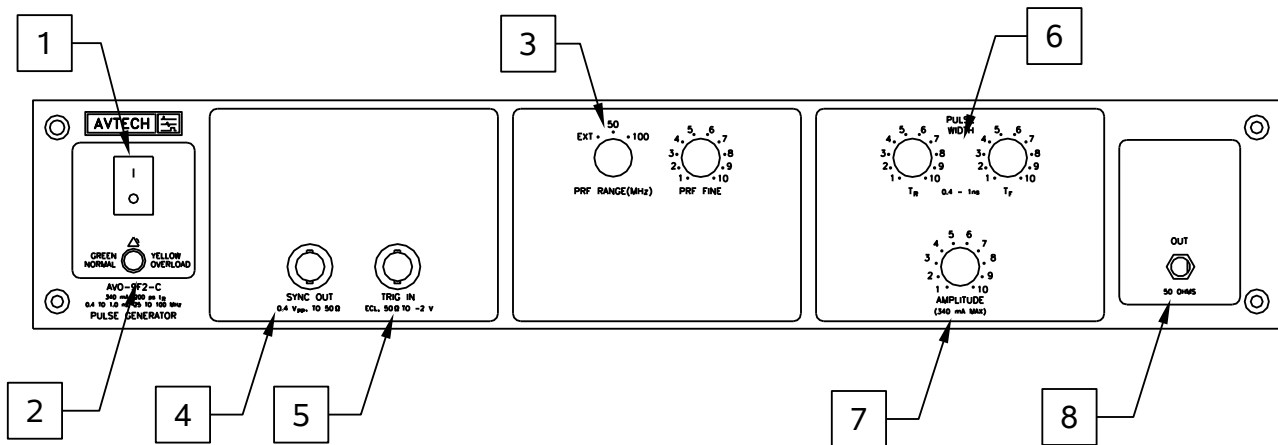

- 1) POWER Switch. This is the main power switch. When turning the instrument on, there may be a delay of several seconds before the instrument appears to respond.
- 2) OVERLOAD Indicator. When the instrument is powered, this indicator is normally green, indicating normal operation. If this indicator is yellow, an internal automatic overload protection circuit has been tripped. If the unit is overloaded (by operating at an exceedingly high duty cycle or by operating into a very low impedance), the protective circuit will disable the output of the instrument and turn the indicator light yellow. The light will stay yellow (i.e. output disabled) for about 5 seconds after which the instrument will attempt to re-enable the output (i.e. light green) for about 1 second. If the overload condition persists, the output will be disabled again (i.e. light yellow) for another 5 seconds. If the overload condition has been removed, the instrument will resume normal operation.

This overload indicator may flash yellow briefly at start-up. This is not a cause for concern.

- 3) PRF Range Switch. This switch sets the pulse repetition frequency (PRF) range of the internal oscillator. The marked value of each position is the upper limit of the 2:1 range, approximately. The vernier dial beside the switch varies the PRF within the set range.

If this switch is set to the “EXT” position, the instrument is triggered by a signal applied to the TRIG connector, rather than by the internal oscillator.

- 4) TRIG Connector. When the PRF Range Switch is set to “EXT”, the instrument is triggered by an ECL-level (LOW = -1.6V, HIGH = -0.8V) square wave (50% duty cycle) applied to this connector. This input is terminated internally with 50 Ohms to -2V.

- 5) SYNC Connector. This output may be used to trigger oscilloscopes or other equipment. It is active in both the internal and external trigger modes. This output provides an AC-coupled 400 mV (peak-to-peak) square wave with the same pulse repetition frequency as the main output.
- 6) Pulse Width Control. These two one-turn controls vary the output pulse width and pulse shape. TR controls the leading edge of the pulse while TF controls the falling edge. Clockwise rotation of TR and TF increases the output pulse width. See the “General Operating Notes” section for more details.
- 7) Amplitude Control. This dial controls the amplitude.
- 8) OUT Connector. This SMA connector is connected to the output module, when the output module is used to drive a diode load. If the output module is not used, this output will generate up to 20V into a load impedances of 50Ω. (NOTE: when the output module is not used, this output *requires* a 50Ω load to function properly).

REAR PANEL CONTROLS

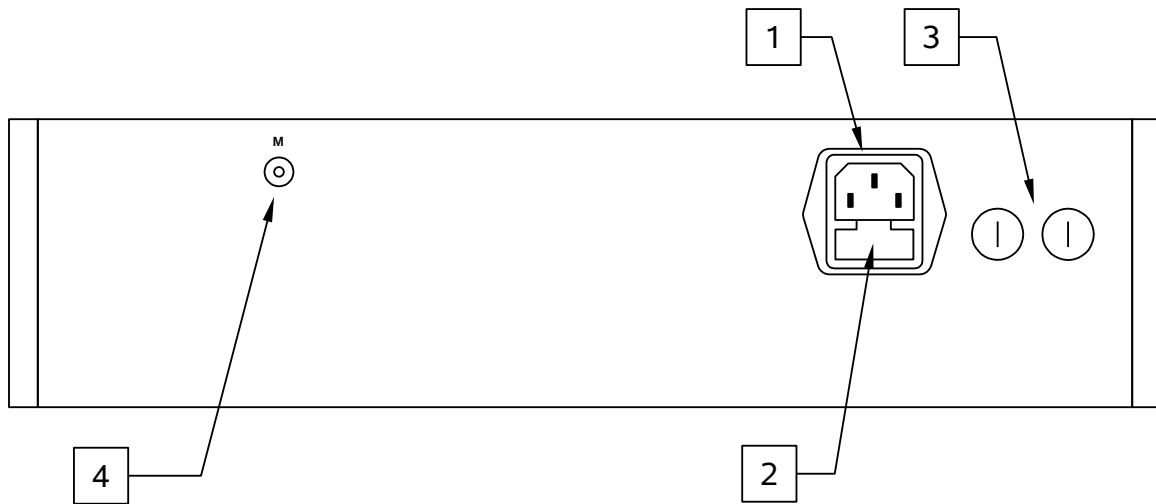

1. AC POWER INPUT. An IEC-320 C14 three-pronged recessed male socket is provided on the back panel for AC power connection to the instrument. One end of the detachable power cord that is supplied with the instrument plugs into this socket.
2. AC FUSE DRAWER. The two fuses that protect the AC input are located in this drawer. Please see the “FUSES” section of this manual for more information.
3. DC FUSES. These two fuses protect the internal DC power supplies. Please see the “FUSES” sections of this manual for more information.
4. M OUTPUT CONNECTOR. This SMA connector output provides a $\div 11$ attenuated coincident replica of main output, for monitoring purposes. When used, it must be terminated with a 50 Ohm load.

GENERAL INFORMATION

MINIMAL TEST ARRANGEMENT - WITHOUT OUTPUT MODULE

The AVO-9F2-C-AK1-QTKB-N-AC22 can be tested initially without the supplied output module. If the output module is not used, the mainframe output generates 0 to -20V into a 50 Ohm load, as illustrated below:

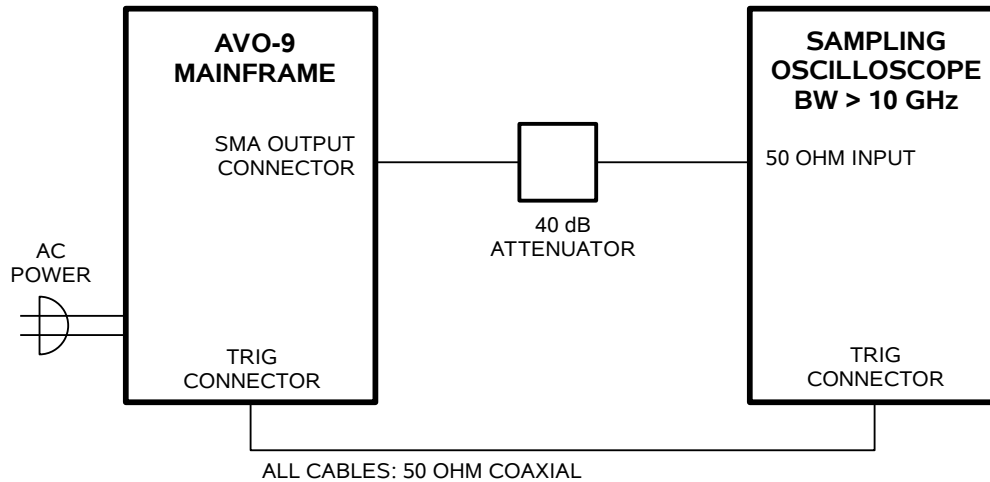

Since most sampling oscilloscopes have limited input amplitude ranges, attenuators are required.

When the output module is not used, a 50 Ohm load impedance is *required* for proper test operation.

NORMAL TEST ARRANGEMENT

To fully test the instrument, and for normal operation, the output module must be connected as shown below:

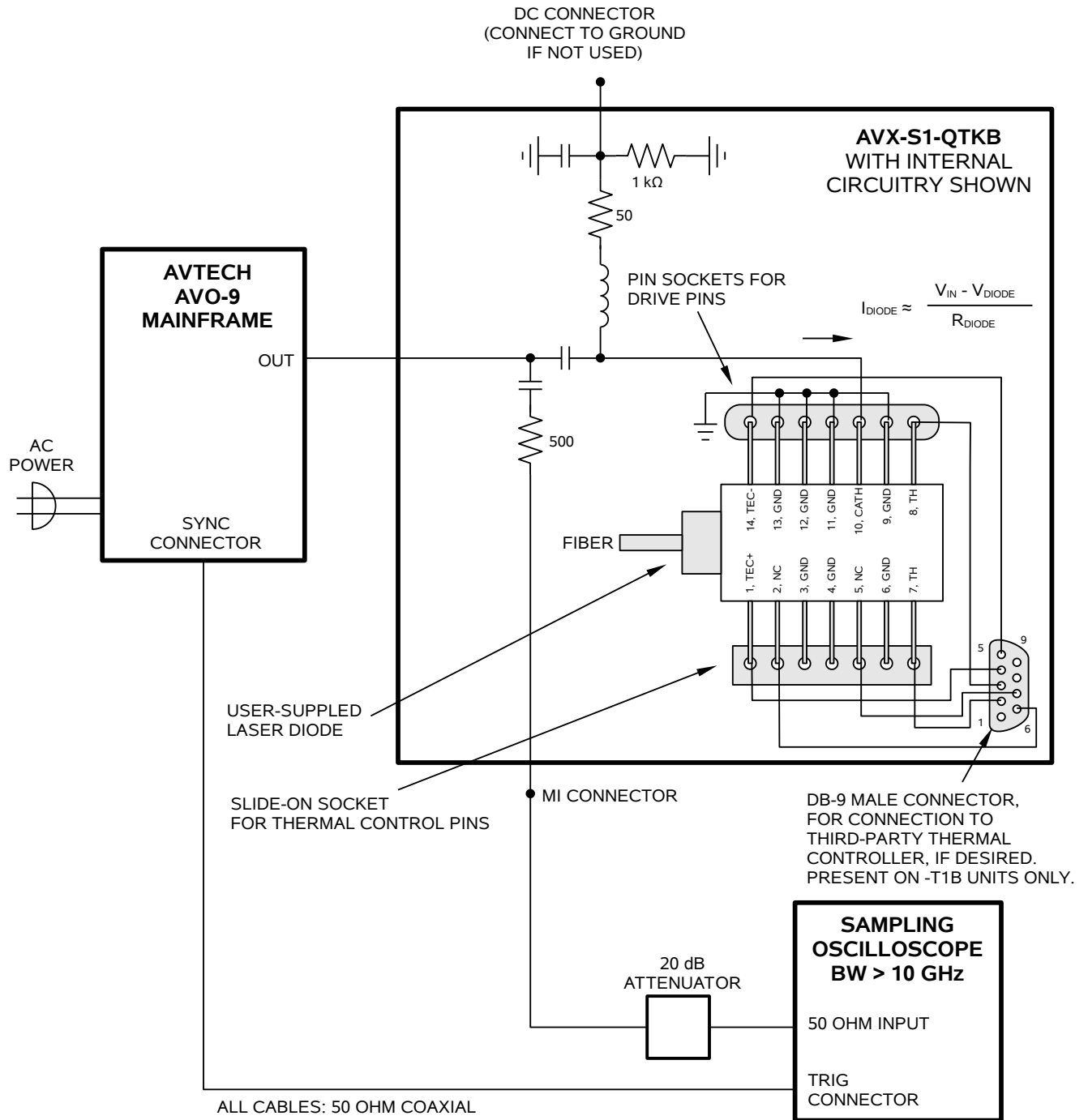

The diode load is inserted into the socket on the output module. The mechanical layout of the socket is shown below:

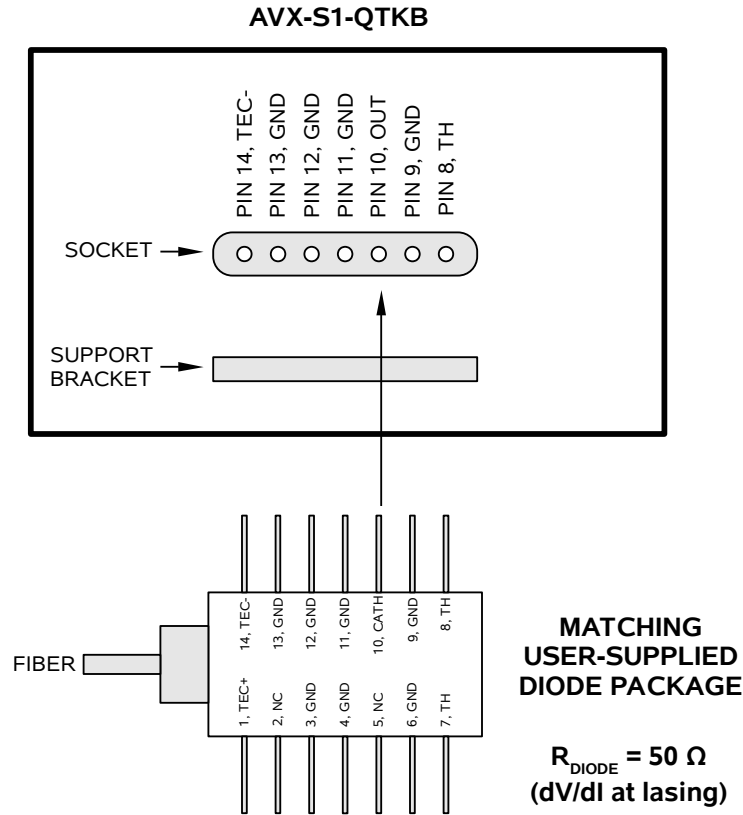

NOTE: Trim the diode leads to **no longer than 1.0 cm in length**. If the leads are longer than that, they may cause an internal short circuit in the output module, which may cause damage to the diode and the output module.

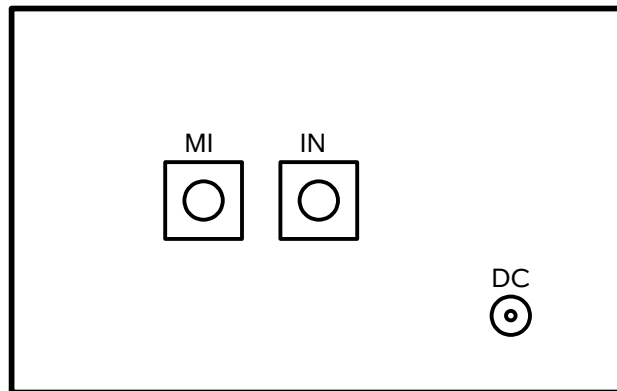

AVX-S1-QTKB OUTPUT MODULE, CONNECTOR VIEW

An oscilloscope may be used to monitor the MI output, the location of which is shown in the figure above. A forward DC bias may be applied to the laser diode by connecting a DC potential of 0 to -10 Volts to the DC solder terminal. The application of a small forward

bias often yields a more ideal diode current waveform (as observed on the MI port). Note that the DC port must be shorted to ground if a bias is not applied.

THERMAL CONTROL

This model includes a DB-9 male connector that will mate to third-party temperature controllers. These third-party controller provide a means of controlling the thermoelectric cooler that is typically present in butterfly-packaged laser diodes, if desired. The need for cooling is dependent on the user's application. Cooling is generally recommended by device manufacturers.

DB-9 pin 2 connects to diode pin 7 (TH).

DB-9 pin 3 connects to diode pin 8 (TH).

DB-9 pin 4 connects to diode pin 1 (TEC+).

DB-9 pin 5 connects to diode pin 14 (TEC-).

DB-9 pin 6 connects to diode pin 2 (future use).

DB-9 pin 7 connects to diode pin 5 (future use).

The remaining DB-9 pins are unconnected.

AMPLITUDE CONTROL

When using the output module, the pulse current through the diode load is given by:

$$I_{\text{DIODE}} = (V_{\text{SET}} - V_{\text{DIODE}}) / R_{\text{DIODE}}$$

where V_{SET} is the amplitude setting on the mainframe (between 0 and -20V), V_{DIODE} is the voltage drop across the diode (-2 to -3V typically), and R_{DIODE} is the resistance internal to the laser diode (ideally 50Ω).

The AVO-9F2-C-AK1-QTKB-N-AC22 can deliver up to 20V into a 50 Ohms. This means that if your diode voltage is 3V, then you can obtain up to $(20V - 3V) / 50 \text{ Ohms} = 340 \text{ mA}$ of current, approximately.

PULSE WIDTH CONTROL

The output pulse shape is determined by the two front panel controls TR and TF. TR controls the leading edge of the pulse while TF controls the falling edge. Clockwise rotation of TR and TF increases the output pulse width.

Initially rotate the TF pot fully clockwise and set the TR pot at mid-range. The output amplitude is controlled by the front panel AMP control and by the input signal level. Initially the AMP control should be set maximum clockwise. The output will resemble the following (for positive amplitudes):

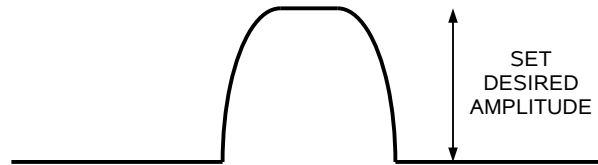

Having obtained an output of the form shown above, the desired pulse width is then obtained by adjusting the two front panel pots TR and TF. Rotate TR counterclockwise from the position set earlier until a sharp 200 ps leading edge is observed. Then rotate TF counterclockwise until the desired pulse width and fall time are obtained.

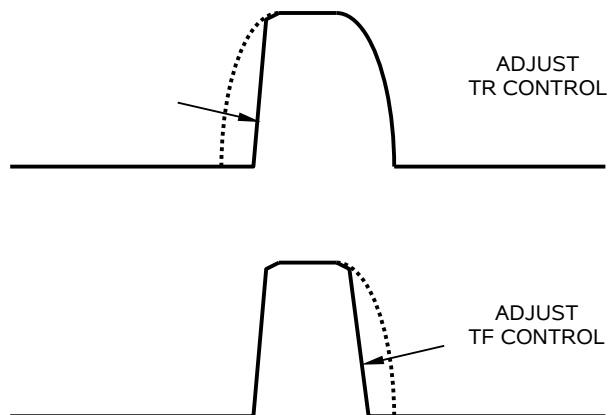

Further iterative adjustments of TR and TF will be necessary to simultaneously obtain the lowest rise time, lowest fall time, the desired pulse width, and pulse top shape, and low spurious signal level. Some additional adjustment of signal level may be necessary to obtain the desired amplitude. If the input frequency is then changed it will be necessary to readjust AMP, TR and TF to establish the required pulse shape.

PULSE WIDTH / AMPLITUDE INTERACTION

The pulse width and delay of the output pulse may vary slightly with the amplitude setting, particularly at lower amplitudes. For some demanding applications, it may be desirable to use external attenuators in conjunction with the AVO-9F2-C-AK1-QTKB-N-AC22, instead of generating a low-amplitude pulse directly.

THERMAL / OVERLOAD ALARMS

This instrument contains several protection circuits and alarms.

Never operate under conditions where the generated amplitude exceeds 20V. The overload light may come on (temporarily disabling the output) if the amplitude is too high.

The instrument also contains thermal sensors to detect overheating of the output stage. If the output stage becomes too hot, an audible alarm will sound and the output triggering will stop until the temperature has decreased sufficiently.

The protection circuits will be very aggressive if the output amplitude exceeds 20V. If the alarms activate, reduce the output amplitude, or turn the instrument off and allow it to cool for a few minutes.

PROTECTING YOUR INSTRUMENT

DO NOT EXCEED 100 MHz

The output stage may be damaged if triggered by an external signal at a pulse repetition frequency greater than 100 MHz.

DO NOT GO BELOW 25 MHz

The output stage may be damaged if triggered by an external signal at a pulse repetition frequency less than 25 MHz.

KEEP THE AMPLITUDE BELOW 20V

It is possible to shape the output pulse such that the output amplitude exceeds 20 Volts. This should be avoided, to avoid excessive internal power dissipation.

USE A 50Ω LOAD

The mainframe output stage may be damaged if the output is not terminated into the output module or a 50Ω dummy load.

INSTALL THE DIODE CORRECTLY

NOTE: Trim the diode leads to **no longer than 1.0 cm in length**. If the leads are longer than that, they may cause an internal short circuit in the output module, which may cause damage to the diode and the output module.

MECHANICAL INFORMATION

TOP COVER REMOVAL

If necessary, the interior of the instrument may be accessed by removing the four Phillips screws on the top panel. With the four screws removed, the top cover may be slid back (and off).

 Always disconnect the power cord and allow the instrument to sit unpowered for 10 minutes before opening the instrument. This will allow any internal stored charge to discharge.

There are no user-adjustable internal circuits. For repairs other than fuse replacement, please contact Avtech (info@avtechpulse.com) to arrange for the instrument to be returned to the factory for repair. Service is to be performed solely by qualified service personnel.

 Caution: High voltages are present inside the instrument during normal operation. Do not operate the instrument with the cover removed.

RACK MOUNTING

A rack mounting kit is available. The -R5 rack mount kit may be installed after first removing the one Phillips screw on the side panel adjacent to the front handle.

ELECTROMAGNETIC INTERFERENCE

To prevent electromagnetic interference with other equipment, all used outputs should be connected to shielded loads using shielded coaxial cables. Unused outputs should be terminated with shielded coaxial terminators or with shielded coaxial dust caps, to prevent unintentional electromagnetic radiation. All cords and cables should be less than 3m in length.

MAINTENANCE

REGULAR MAINTENANCE

This instrument does not require any regular maintenance.

On occasion, one or more of the four rear-panel fuses may require replacement. All fuses can be accessed from the rear panel. See the “FUSES” section for details.

CLEANING

If desired, the interior of the instrument may be cleaned using compressed air to dislodge any accumulated dust. (See the “TOP COVER REMOVAL” section for instructions on accessing the interior.) No other cleaning is recommended.

WIRING DIAGRAMS

WIRING OF AC POWER

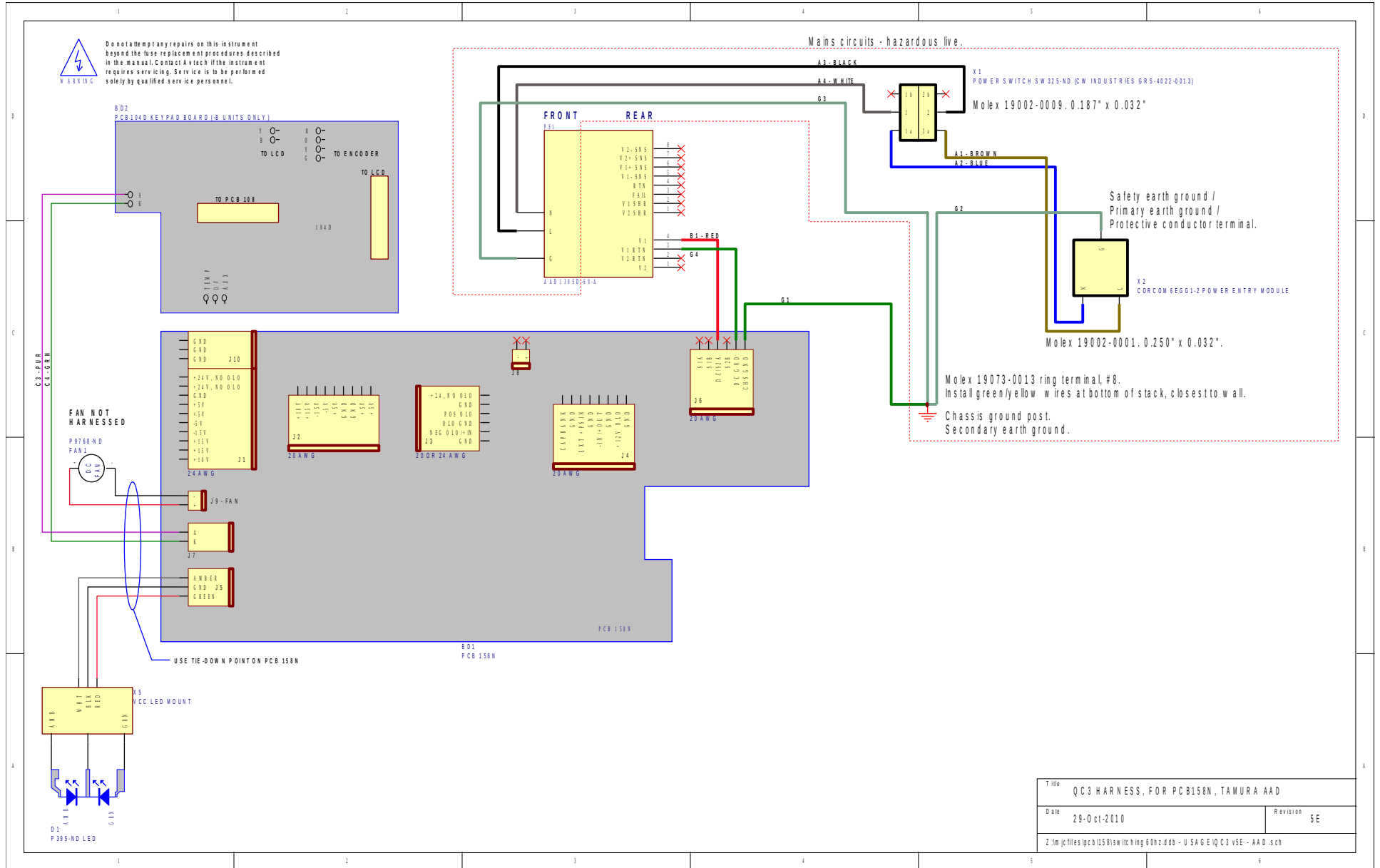

Title		QC3 HARNESS, FOR PCB158N, TAMURA AAD	
Date	29-Oct-2010	Revision	5E
Z:\m\j\files\pcb1581\sw\it\hng\60hz.dbb - U.S.AGE IQ C3 v5E - AAD.sch			

PCB 158N - LOW VOLTAGE POWER SUPPLY, 1/3

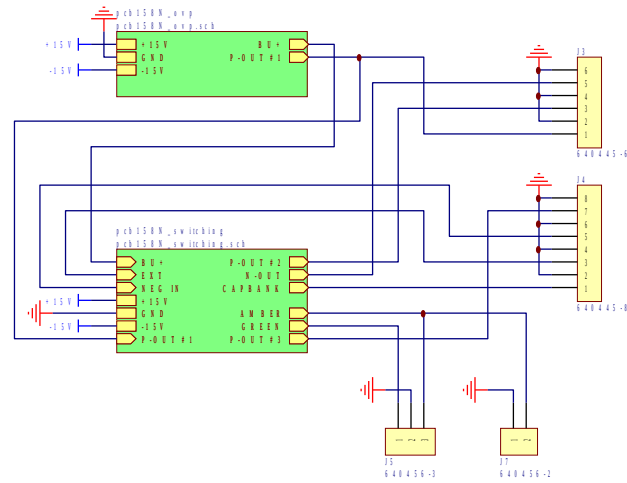

Title		LOW VOLTAGE DC/DC POWER SUPPLY
Date	12-Dec-2008	Revision
Z:\m\jcf\files\pcb\158\switching\60hz.ddb - 158N\pcb\158N.sch		

PCB 158N - LOW VOLTAGE POWER SUPPLY, 2/3

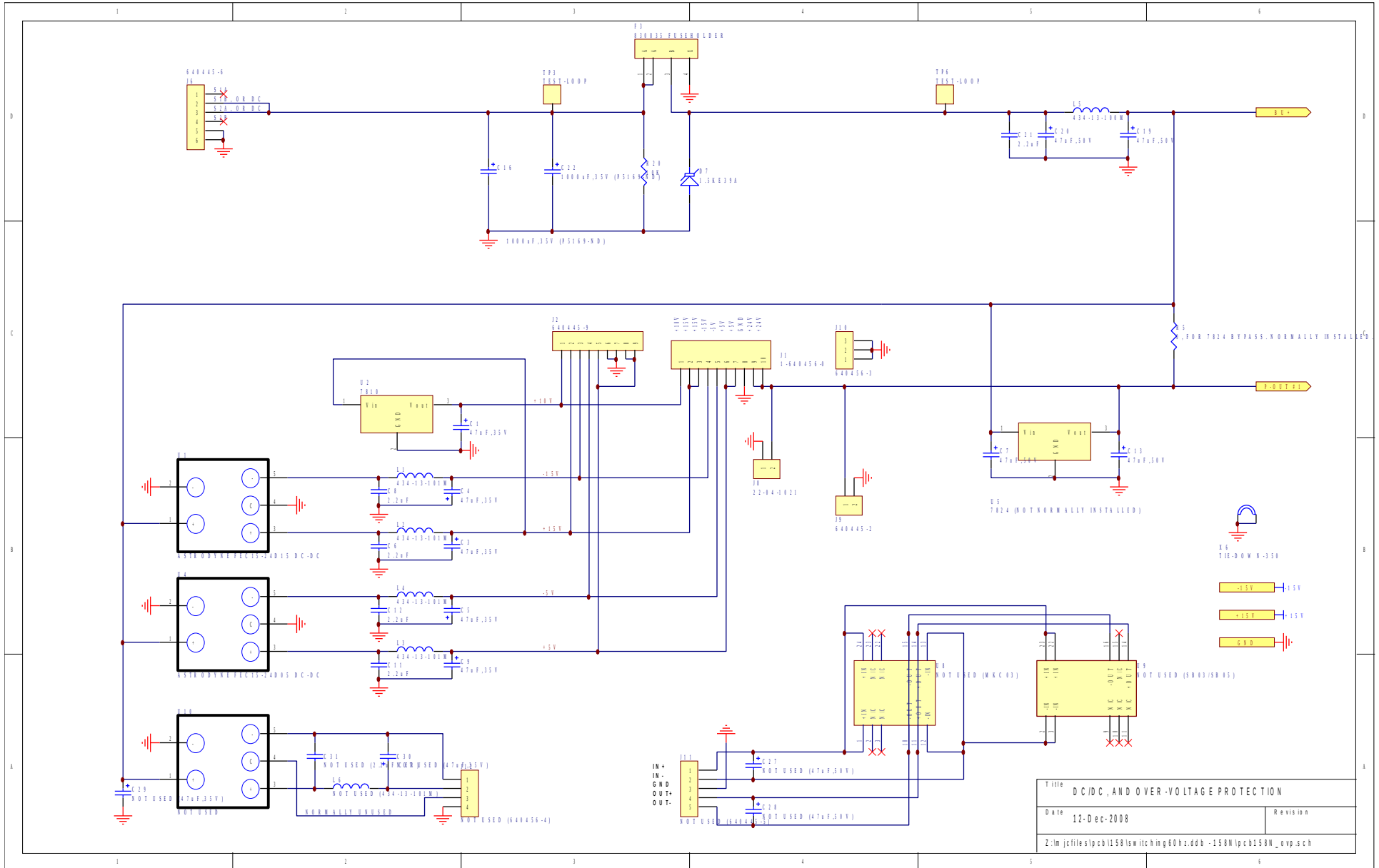

PCB 158N - LOW VOLTAGE POWER SUPPLY, 3/3

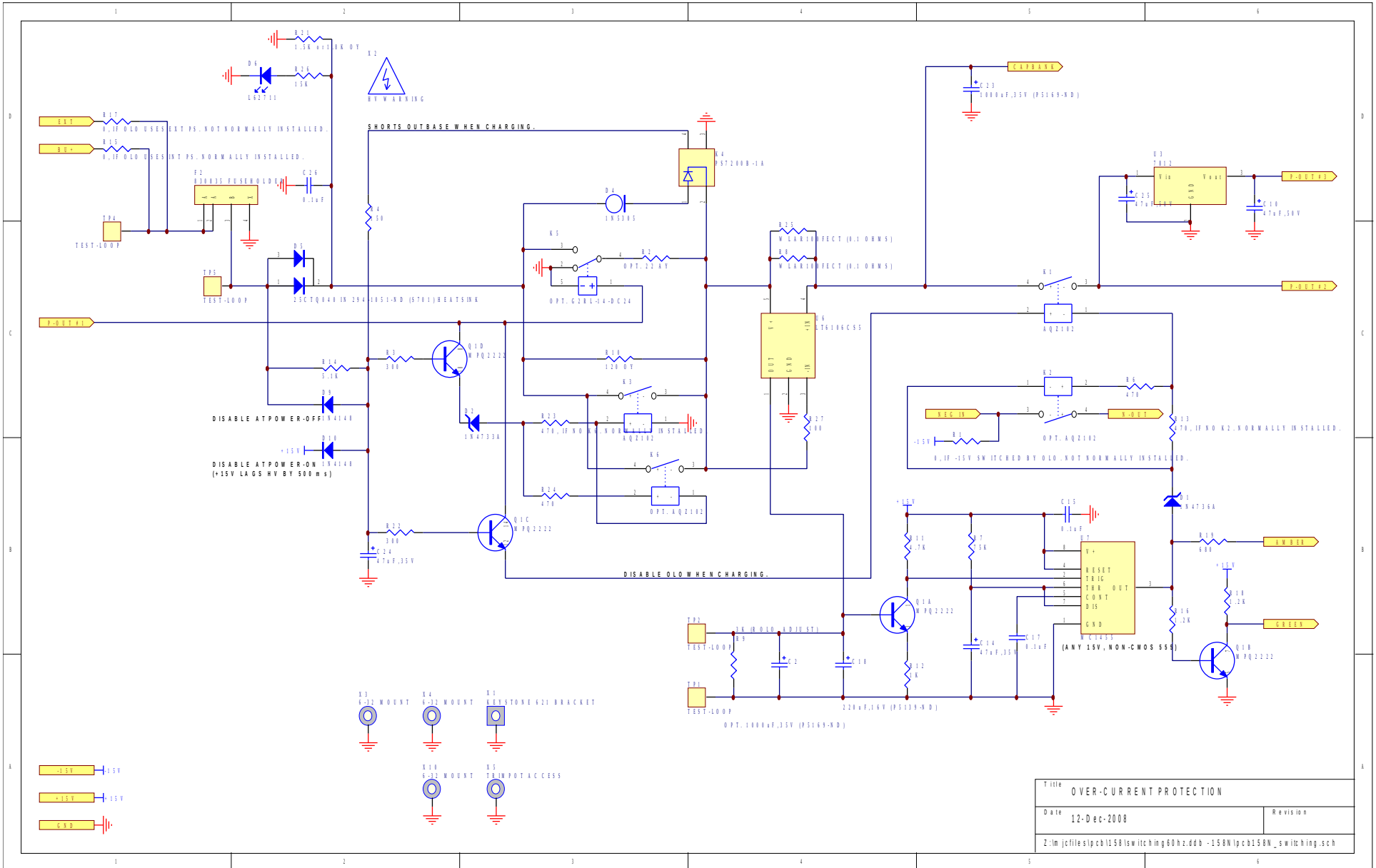

PCB 94F – ALARM BOARD

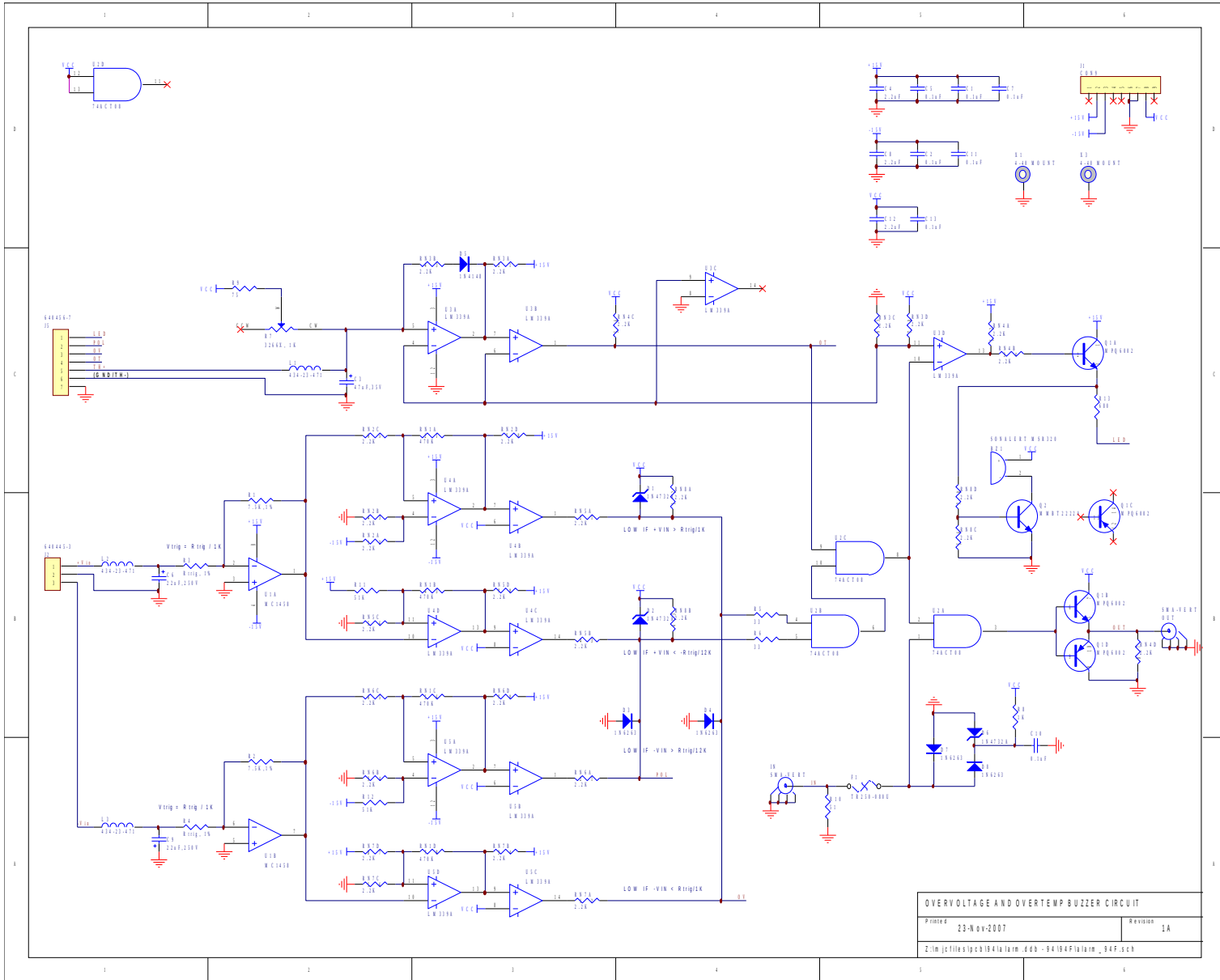

PCB 216A - PRF/PW TWEAKING PCB

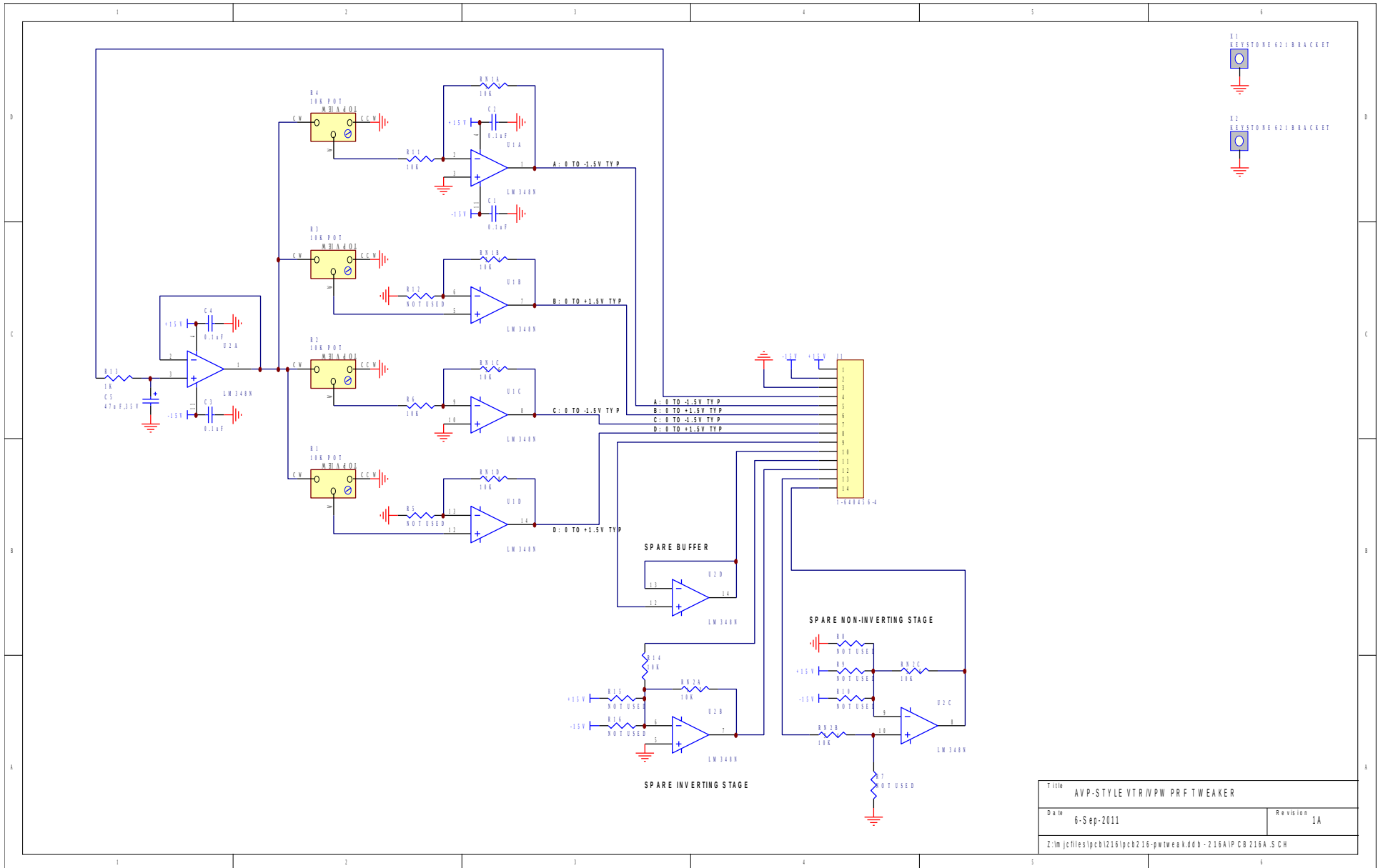

Title AVP-STYLE VTR/PW PRF TWEAKER	
Date 6-Sep-2011	Revision 1A
Z:\m\jchies\pcb\216\pcb216-prfwear.ddb - 216A\PCB 216A.SCH	

MAIN WIRING

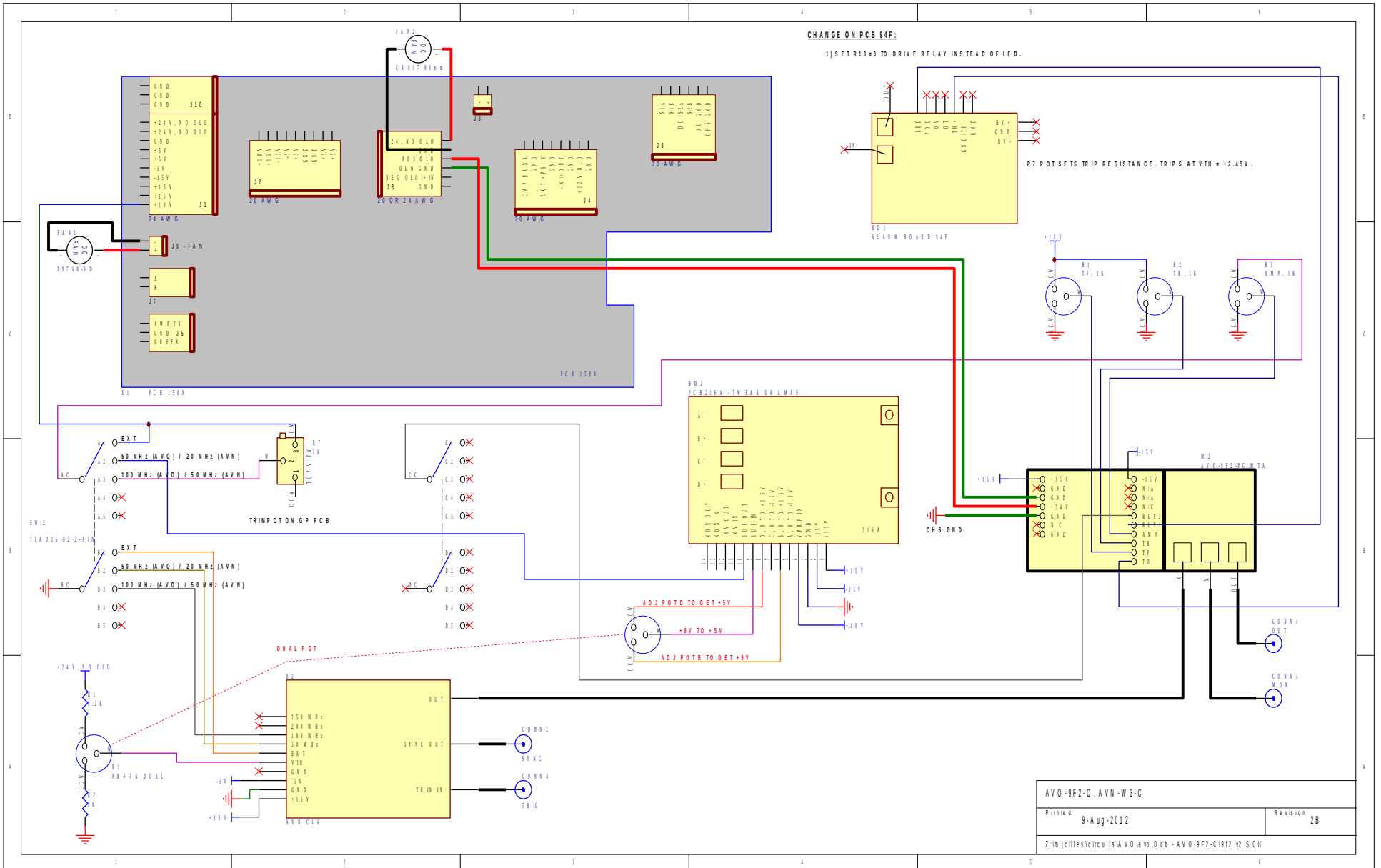

PERFORMANCE CHECKSHEET