

INSTRUCTIONS

MODEL AVO-9G-C-OP1 PULSE GENERATOR

MODEL AVX-S1-MI BIAS INSERTION UNIT

S.N.: 8203

WARRANTY

Avtech Electrosystems Ltd. warrants products of its manufacture to be free from defects in material and workmanship under conditions of normal use. If, within one year after delivery to the original owner, and after prepaid return by the original owner, this Avtech product is found to be defective, Avtech shall at its option repair or replace said defective item. This warranty does not apply to units which have been disassembled, modified or subjected to conditions exceeding the applicable specifications or ratings. This warranty is the extent of the obligation assumed by Avtech with respect to this product and no other warranty or guarantee is either expressed or implied.

TECHNICAL SUPPORT

Phone: 613-226-5772 or 1-800-265-6681

Fax: 613-226-2802 or 1-800-561-1970

E-mail: info@avtechpulse.com

World Wide Web: <http://www.avtechpulse.com>

EC Declaration of Conformity

We

Avtech Electrosystems Ltd.
P.O. Box 5120, Stn. F
Ottawa, Ontario
Canada K2C 3H4

declare that the AVO-9G-C pulse generator meets the intent of Directive 89/336/EEC for Electromagnetic Compatibility. Compliance pertains to the following specifications as listed in the official Journal of the European Communities:

EN 50081-1 Emission

EN 50082-1 Immunity



TABLE OF CONTENTS

WARRANTY.....	2
EC Declaration of Conformity.....	4
TABLE OF CONTENTS.....	5
PULSE GENERATOR TEST ARRANGEMENT (AVX-S1 Module Disconnected).....	6
OPERATING INSTRUCTIONS.....	7
PULSE GENERATOR TEST ARRANGEMENT (AVX-S1 Module Connected).....	9
AVX-S1.....	10
AVX-S SPECIFICATIONS.....	13
FRONT PANEL CONTROLS.....	14
BACK PANEL CONTROLS.....	16
TOP COVER REMOVAL AND RACK MOUNTING.....	17
POWER SUPPLY AND FUSE REPLACEMENT.....	18
OP-1 OPERATING INSTRUCTIONS (AN-101-9G).....	20
PERFORMANCE CHECK SHEET.....	23

PULSE GENERATOR TEST ARRANGEMENT (AVX-S1 Module Disconnected)

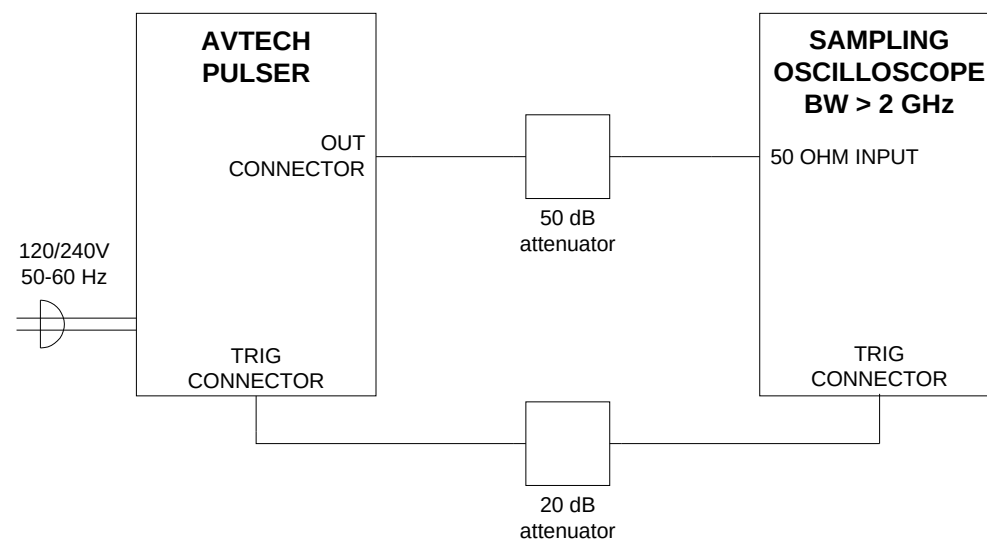

ALL CABLES: 50 OHM COAXIAL

OPERATING INSTRUCTIONS

- 1) For front panel manual control of the output parameters, the rear panel LOCAL-REMOTE switch must be in the LOCAL position. For remote control using a personal computer, the switch should be in the REMOTE position. See the AN-101-9G section (at the end of the manual) for the instructions of this mode of operation.
- 2) The bandwidth capability of components and instruments used to display the pulse generator output signal (attenuators, cables, connectors, etc.) should exceed 2 GHz.
- 3) The use of 50 dB attenuator at the scope vertical input channel will insure a peak input signal to the scope of less than one Volt (necessary only if sampling scope used). If a high impedance real time scope is used, the pulse generator should be terminated using a shunt 50 Ohm resistor.
- 4) The TRIG output channel provides TTL level signals. To avoid overdriving the TRIG input channel of some scopes, a 30 dB attenuator should be placed at the input to the scope trigger channel. The TRIG output precedes the main output when the front panel ADVANCE-DELAY switch is in the ADVANCE position. The TRIG output lags the main output when the switch is in the DELAY position.
- 5) To obtain a stable output display the PW and PRF controls on the front panel should be set mid range. The front panel TRIG toggle switch should be in the INT position. The DELAY controls and the scope triggering controls are then adjusted to obtain a stable output. The scope may then be used to set the desired PRF by rotating the PRF controls.
- 6) The output pulse width is controlled by means of the front panel one turn PW control (ten turn control for units with -PWT option).
- 7) The output pulse amplitude is controlled by means of the front panel one turn AMP control (ten turn control for units with the -AT option).
- 8) An external clock may be used to control the output PRF of the AVO unit by setting the front panel TRIG toggle switch in the EXT position and applying a 50 ns (or wider) TTL level pulse to the TRIG BNC connector input. For operation in this mode, the scope time base must also be triggered by the external clock rather than from the TRIG output.
- 9) AVO units with a serial number higher than 5600 are protected by an automatic overload protective circuit which controls the front panel overload light. If the unit is overloaded (by operating at an exceedingly high duty cycle or by operating

into a short circuit), the protective circuit will turn the output of the instrument OFF and turn the indicator light ON. The light will stay ON (i.e. output OFF) for about 5 seconds after which the instrument will attempt to turn ON (i.e. light OFF) for about 1 second. If the overload condition persists, the instrument will turn OFF again (i.e. light ON) for another 5 seconds. If the overload condition has been removed, the instrument will turn on and resume normal operation. Overload conditions may be removed by:

- 1) Reducing PRF (i.e. switch to a lower range)
 - 2) Reducing pulse width (i.e. switch to a lower range)
 - 3) Removing output load short circuit (if any)
- 10) The unit can be converted from 120 to 240V 50-60 Hz operation by adjusting the voltage selector card in the rear panel fused voltage selector-cable connector assembly.
- 11) For additional assistance:
- Tel: (613) 226-5772
Fax: (613) 226-2802
Email: info@avtechpulse.com

PULSE GENERATOR TEST ARRANGEMENT (AVX-S1 Module Connected)

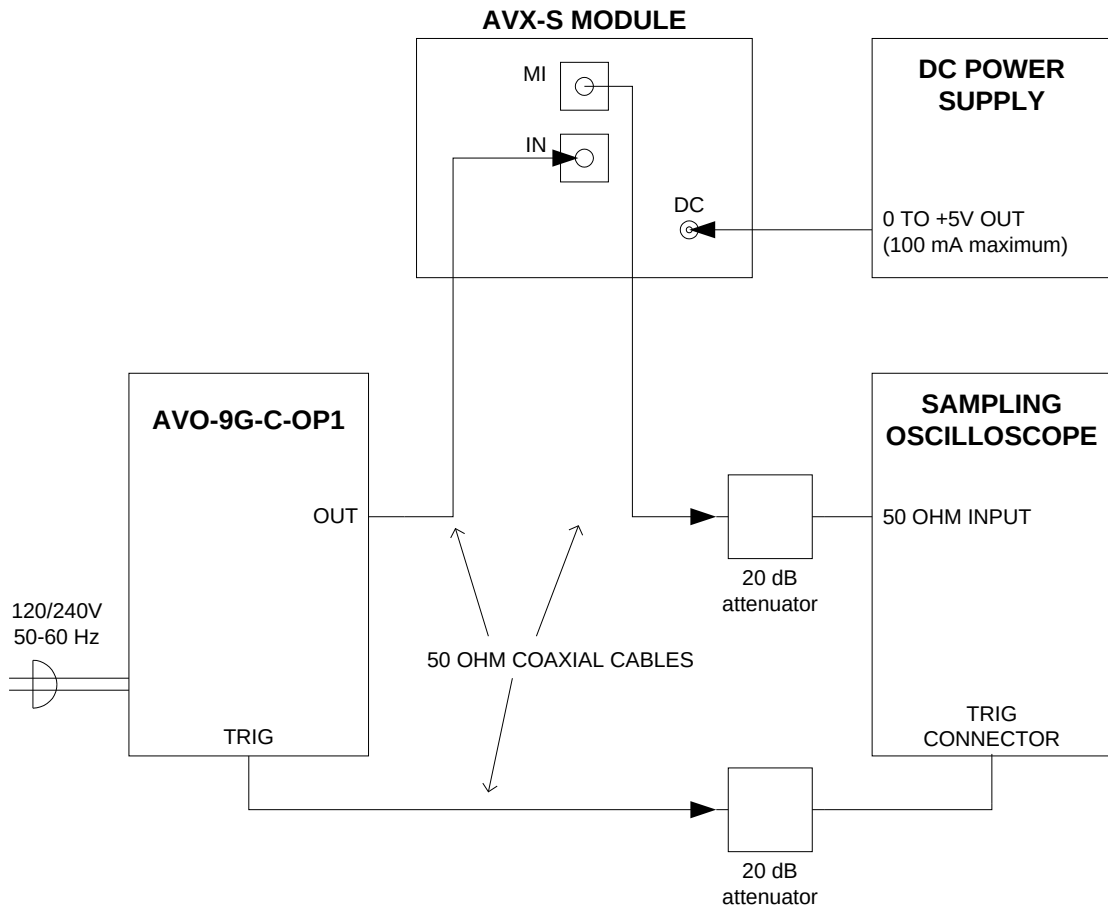

AVX-S1

- 1) A general description of the AVX-S1 module is given in the enclosed data sheet.
- 2) The AVX-S1 module should be connected to the AVO-9G-C mainframe via the supplied 24" RG174 cable. The diode current may be monitored by connecting the MI and MV output ports to the sampling scope via 20 dB attenuators. The output amplitude (V_{MI} , Volts) and diode current (I_D , Amps) are related as follows:

$$I_D = 0.4 V_{MI}$$

- 3) The laser diode anode must connect directly to the centre pin of the SMA connector outside of the AVX-S1 module (lead lengths should not exceed 1 cm).
- 4) A forward DC bias may be applied to the laser diode by connecting a DC potential of 0 to ± 5 Volts to the DC solder terminal. The application of a small forward bias often yields a more ideal diode current waveform (as observed on the MI port). Note that the DC port must be shorted to ground if a bias is not applied.

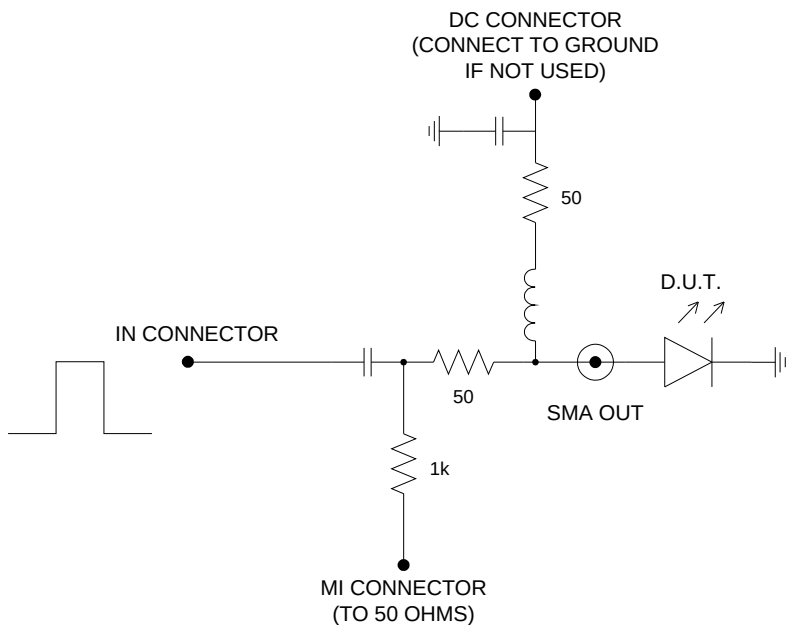

AVX-S1-MD FUNCTIONAL EQUIVALENT CIRCUIT (S/N 8203)

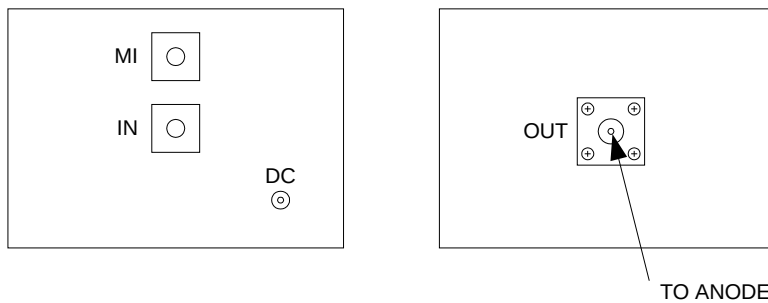

PACKAGE (S/N 8203)

AVX-S LASER DIODE BIAS INSERTION UNITS DATA SHEET

AVX-S SPECIFICATIONS

FRONT PANEL CONTROLS

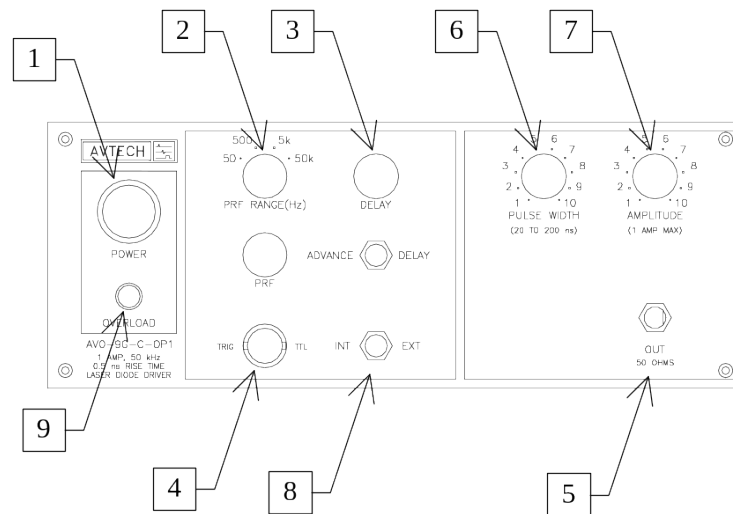

- (1) ON-OFF Switch. Applies basic prime power to all stages.
- (2) PRF Control. PRF RANGE and PRF controls determine output PRF as follows:

	PRF MIN	PRF MAX
Range 1	5 Hz	50 Hz
Range 2	50 Hz	500 Hz
Range 3	500 Hz	5 kHz
Range 4	5 kHz	50 KHz

The operating PRF should be set using a scope.

- (3) DELAY Control. Controls the relative delay between the reference output pulse provided at the TRIG output (4) and the main output (5). This delay is variable over the range of 0 to about 0.2 us. The TRIG output precedes the main output when the ADVANCE-DELAY switch is in the ADVANCE position and lags when the switch is in the DELAY position.
- (4) TRIG Output. This output is used to trigger the scope time base. The output is a TTL level 100 ns (approx.) pulse capable of driving a fifty Ohm load.
- (5) OUT Connector. SMA connector provides output to a fifty Ohm load.
- (6) PW Control. A one turn control which varies the output pulse width from 20 ns to 200 ns.

- (7) AMP Control. A one turn control which varies the output pulse amplitude to a fifty Ohm load.
- (8) EXT-INT Control. With this toggle switch in the INT position, the PRF of the AVO unit is controlled via an internal clock which in turn is controlled by the PRF controls. With the toggle switch in the EXT position, the AVO unit requires a 50 ns (or wider) TTL level pulse applied at the TRIG input in order to trigger the output stages. In addition, in this mode, the scope time base must be triggered by the external trigger source.
- (9) OVERLOAD. AVO units with a serial number higher than 5600 are protected by an automatic overload protective circuit which controls the front panel overload light. If the unit is overloaded (by operating at an exceedingly high duty cycle or by operating into a short circuit), the protective circuit will turn the output of the instrument OFF and turn the indicator light ON. The light will stay ON (i.e. output OFF) for about 5 seconds after which the instrument will attempt to turn ON (i.e. light OFF) for about 1 second. If the overload condition persists, the instrument will turn OFF again (i.e. light ON) for another 5 seconds. If the overload condition has been removed, the instrument will turn on and resume normal operation. Overload conditions may be removed by:
- 1) Reducing PRF (i.e. switch to a lower range)
 - 2) Reducing pulse width (i.e. switch to a lower range)
 - 3) Removing output load short circuit (if any)

BACK PANEL CONTROLS

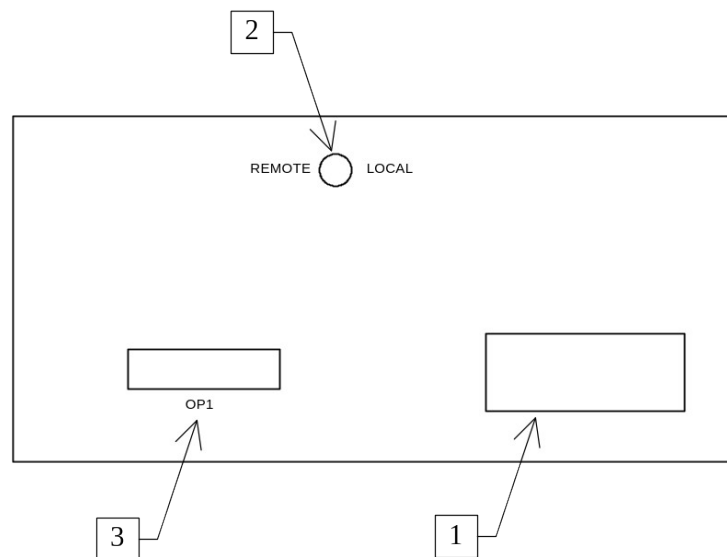

- (1) FUSED CONNECTOR, VOLTAGE SELECTOR. The detachable power cord is connected at this point. In addition, the removable cord is adjusted to select the desired input operating voltage. The unit also contains the main power fuse.

For AC line voltages of 110-120V, the power selector card should be installed so that the "120" marking is visible from the rear of the instrument.

For AC line voltages of 220-240V, the power selector card should be installed so that the "240" marking is visible from the rear of the instrument.

If it is not set for the proper voltage, remove the fuse and then grasp the card with a pair of pliers and remove it. Rotate horizontally through 180 degrees. Reinstall the card and the correct fuse.

In the 120V setting, a 0.5A slow blow fuse is required. In the 240V setting, a 0.25A slow blow fuse is required.

- (2) LOCAL REMOTE SWITCH. This two-position switch must be in the LOCAL position to operate this instrument from the front panel controls. To control the instrument using your personal computer, the switch must be in the REMOTE position.
- (3) OP1 CONNECTOR. GPIB cable (supplied) connects between this connector and your personal computer.

TOP COVER REMOVAL AND RACK MOUNTING

The interior of the instrument may be accessed by removing the four Phillips screws on the top panel. With the four screws removed, the top cover may be slid back (and off).

POWER SUPPLY AND FUSE REPLACEMENT

This instrument has three main fuses, plus two spares. One, which protects the AC input, is located in the rear-panel power entry module, as described in the “Rear Panel Controls” section of this manual. If the power appears to have failed, check the AC fuse first.

The other two fuses (plus two spares) are located on the internal DC power supply, as shown below:

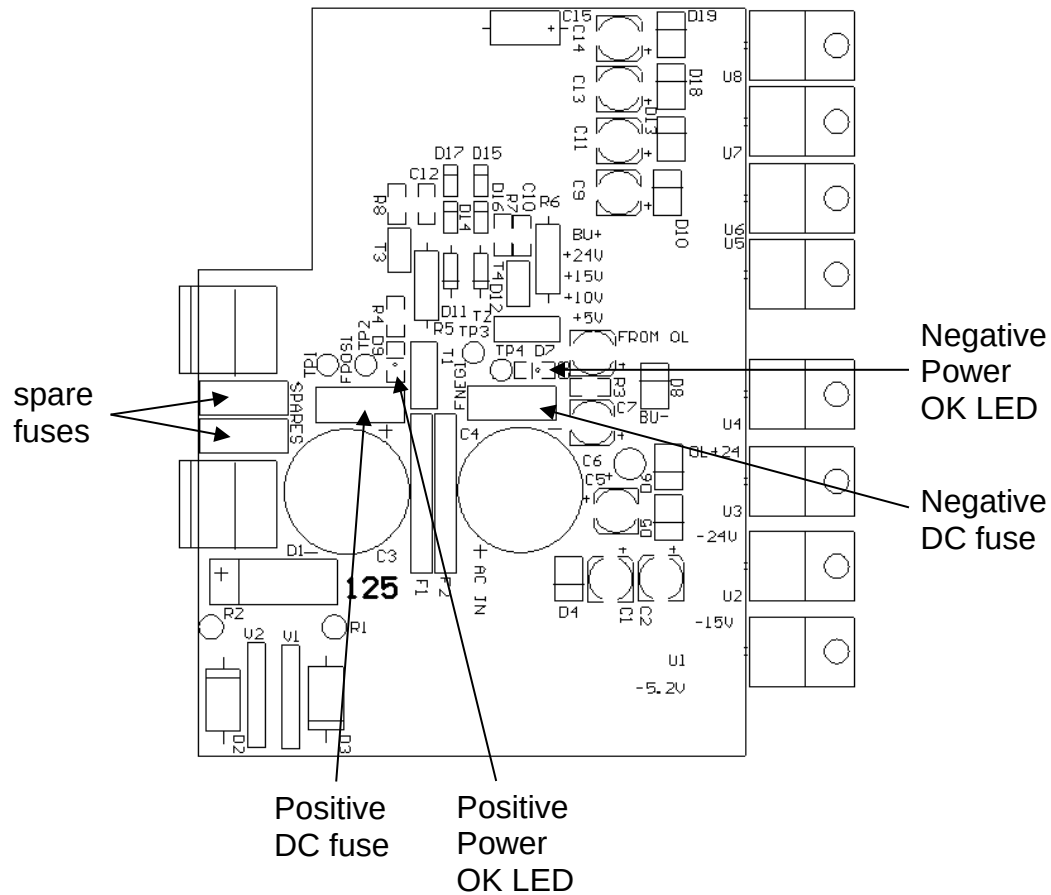

The positive fuse and one of the spare fuses on this circuit board are 1.5A slow-blow fuses, Littlefuse part number R45201.5. (This fuse can be ordered from Digikey, www.digikey.com. The Digikey part number is F1344CT-ND). The negative fuse and the second spare fuse are 0.5A slow-blow fuses (Littlefuse R452.500, Digikey part number F1341CT-ND).

If you suspect that the DC fuses are blown, follow this procedure:

1. Remove the top cover, by removing the four Phillips screws on the top cover and then sliding the cover back and off.
2. Locate the two "Power OK" LEDs on the power supply circuit board, as illustrated above.
3. Turn on the instrument.
4. Observe the "Power OK" LEDs. If the fuses are not blown, the two LEDs will be lit (bright red). If one of the LEDs is not lit, the fuse next to it has blown.
5. Turn off the instrument.
6. If a fuse is blown, use needle-nose pliers to remove the blown fuse from its surface-mount holder.
7. Replace the fuse. (Spare 1.5 Amp and 0.5 Amp fuses are provided on the circuit board. They may be transferred to the active fuse locations using needle-nose pliers.)

OP-1 OPERATING INSTRUCTIONS (AN-101-9G)

1.0 Introduction

This section describes how to use the OP-1 GPIB Bus Listener interface for remote computer control of the Avtech pulse generator, by means of the IEEE 488 General Purpose Interface Bus (GPIB).

The available commands and their structure, a typical command sequence and a sample program are included.

In addition, possible methods of incorporating remote duty cycle limit checking and instructions on how to change the GPIB address are provided.

2.0 Interface to the GPIB

The IEEE 488 compatible Bus functions available to the user for GPIB control are as follows: The listed functions define a Bus Listener capability:

-SHO, AH1, T0, TE0, L2, LE0, SR0, RL0, PP0, DC1, DT0, C0.

2.1 Available Commands

The OP-1 GPIB user interface is designed to be used to remotely program the Avtech pulse generator to control the pulse repetition rate, pulse amplitude and delayed (or advanced) trigger output.

The available command acronyms, outputs, units and range of acceptable values for the AVO-9G-C-OP1 generator are defined in the table below:

<u>Acronym</u>	<u>Output</u>	<u>Units</u>	<u>Range</u>	<u>Decades</u>
I	I(current amplitude)	amps	0 to 1	
R	Repetition rate	Hertz	5 to 50000	4
W	Width of pulse	nano-sec	20 to 200	1
D	Delay (trigger)	nano-sec	20 to 200	1
A	Advance (trigger)	nano-sec	20 to 200	1

For example, for a GPIB controller from National Instruments, the following set of commands would be sent:

```
ibwrt "r=100"
ibwrt "i=0.5"
ibwrt "a=50"
ibwrt "w=50"
```

This command sequence will cause the generator to produce an output pulse of width 50 nano-sec and an amplitude of 0.5 amps peak, repeated at a rate of 100 pulses per second. An oscilloscope attached to the generator output will confirm the result. If the generator output trigger port is used, it will be noted that each output pulse will occur 50 nano-sec after the trigger pulse occurs.

2.2 Sample Program

To illustrate the remote control process by means of the GPIB, a sample program written in BASIC is provided. While this example is prepared for use with the B&C MicroSystems PC488 circuit card, the general principles of control apply to any IEEE 488 GPIB Controller.

```
TEST of Pulser Controller
OPEN "PC488" FOR OUTPUT AS #1
PRINT #1, "ABORT"
PRINT #1, "CLEAR"
PRINT #1, "OUTPUT 8;I", 0.5
PRINT #1, "OUTPUT 8;R", 100
PRINT #1, "OUTPUT 8;A", 50
PRINT #1, "OUTPUT 8;W", 50
END
```

3.0 Duty Cycle Limits

Typically, Avtech pulse generators are limited to a maximum duty cycle because of thermal constraints, where duty cycle is the ration of Pulse Width to the reciprocal of the Repetition Rate (i.e.; $R \times W$). Although the generator contains automatic protection against an excessive duty cycle, whenever this protection is activated, the output is inhibited. Therefore, it may be desirable to have the control computer calculate the duty ratio, then generate a warning message to the operator whenever the limits are exceeded (preferably prior to actually sending the command sequence).

This message could caution the user either to reduce the repetition rate or the pulse width, to avoid thermal overload. While this calculation is not mandatory, it

could avoid the annoyance of automatic inhibiting of the generator output.

4.0 Changing the Unit GPIB Address

Since the GPIB data bus address for the pulse generator has been preset to "8" in the factory, commands are required to be sent to this address. However, the user may wish to change the address to any address in the allowed range of 0 to 30. This address may be easily changed by re-setting the GPIB address switch on the GPIB Interface board located inside the pulse generator chassis.

The address is set by means of a five-position "Dipswitch" located on the top of a small circuit card located inside the enclosure near the top rear. The switch may be observed to be set to the default address by noting that the Dipswitch position 4 is set in the OFF position, defining a binary address of 8.

The switch setting is calculated as the sum of the switch weights in the OFF position, calculated as follows: (a switch in the ON position it has a weight of zero):

Switch Number	OFF Weight
1	1
2	2
3	4
4	8
5	16

For example, a switch with positions 1, 4 and 5 set to OFF will result in an address setting of 25 (16 plus 8 plus 1 = 25).

5.0 Trouble-Shooting Aid

In the event that difficulties are encountered communicating via the GPIB interface, two auxiliary communications status indicators have been included on the GPIB interface circuit card. These status indicators are small LED lamps, one which flashes briefly whenever a properly addressed command is received. The second LED will light whenever an out-of-range value or invalid command is received, and will remain lit until a valid command with a valid in-range value is subsequently received.

PERFORMANCE CHECK SHEET