

INSTRUCTIONS

MODEL AVO-9A-C-N-POCC

0 TO 200 mA, 200 ps RISE TIME

HIGH PERFORMANCE LASER DIODE DRIVER

WITH PLUG-IN SOCKET OUTPUT MODULE

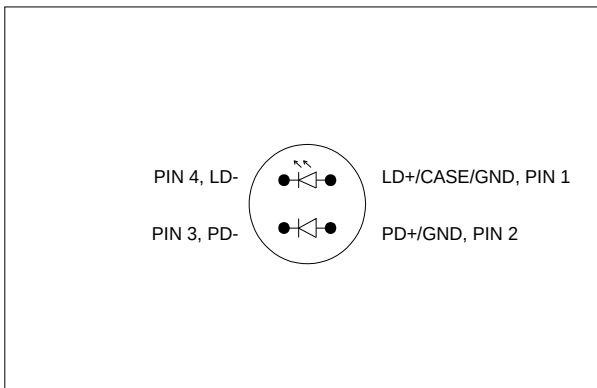

AVX-S1 OUTPUT MODULE, SOCKET VIEW

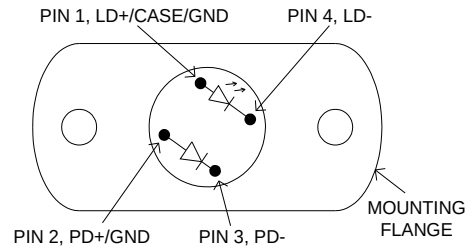

**MATCHING USER-SUPPLIED
DIODE PACKAGE
(BOTTOM VIEW)**

SERIAL NUMBER: _____

WARRANTY

Avtech Electrosystems Ltd. warrants products of its manufacture to be free from defects in material and workmanship under conditions of normal use. If, within one year after delivery to the original owner, and after prepaid return by the original owner, this Avtech product is found to be defective, Avtech shall at its option repair or replace said defective item. This warranty does not apply to units which have been disassembled, modified or subjected to conditions exceeding the applicable specifications or ratings. This warranty is the extent of the obligation assumed by Avtech with respect to this product and no other warranty or guarantee is either expressed or implied.

TECHNICAL SUPPORT

Phone: 613-226-5772 or 1-800-265-6681

Fax: 613-226-2802 or 1-800-561-1970

E-mail: info@avtechpulse.com

World Wide Web: <http://www.avtechpulse.com>

TABLE OF CONTENTS

WARRANTY	2
TECHNICAL SUPPORT	2
TABLE OF CONTENTS	3
INTRODUCTION	4
SPECIFICATIONS	5
INSTALLATION	6
VISUAL CHECK	6
PLUGGING IN THE INSTRUMENT	6
FRONT PANEL CONTROLS	8
REAR PANEL CONTROLS	10
GENERAL INFORMATION	11
MINIMAL TEST ARRANGEMENT - WITHOUT OUTPUT MODULE	11
NORMAL TEST ARRANGEMENT	12
AMPLITUDE CONTROL	14
BASIC PULSE CONTROL	14
PULSE WIDTH / AMPLITUDE INTERACTION	15
TOP COVER REMOVAL	15
ELECTROMAGNETIC INTERFERENCE	15
RACK MOUNTING	15
PROTECTING YOUR INSTRUMENT	16
DO NOT EXCEED 1 MHz	16
USE A 50 Ω LOAD	16
INSTALL THE DIODE CORRECTLY	16
PERFORMANCE CHECKSHEET	17

INTRODUCTION

The AVO-9A-C-N-POCC is a high performance instrument capable of generating up to 200 mA of current into diode loads, at repetition rates up to 1 MHz.

The AVO-9A-C-N-POCC consists of a mainframe unit and an AVX-S1 series output module, which provides a socket into which the user's laser diode may be inserted. The mainframe generates voltage pulses of between 0 and -12V. The output module connects to the instrument mainframe via a detachable 2 foot long coaxial cable. The output module contains the necessary elements to match the laser diode to the pulse generator mainframe. A DC bias current of 0 to ± 100 mA may be applied to the laser diode by applying the desired DC current to a solder terminal on the output module. The output modules include an SMA output connector that provides an attenuated coincident replica of the diode current. An SMA connection to a photo diode detector output is also provided.

The AVX-S1 output module supplied with the AVO-9A-C-N-POCC is specifically designed to accommodate 4-pin 5.6mm diodes with the pinout illustrated below:

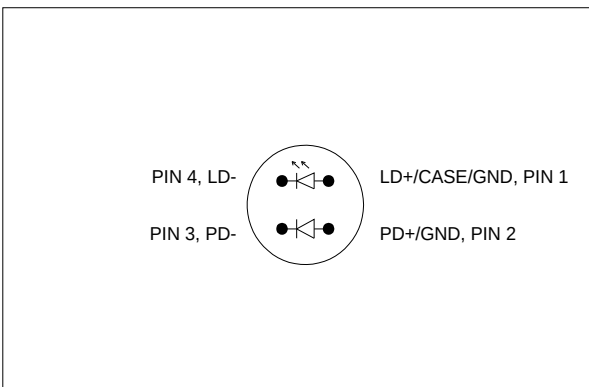

AVX-S1 OUTPUT MODULE, SOCKET VIEW

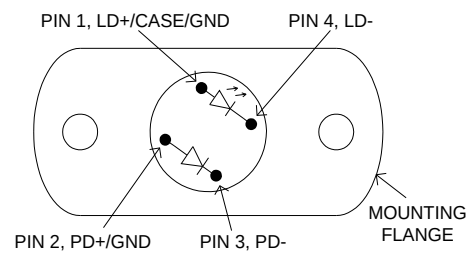

**MATCHING USER-SUPPLIED
DIODE PACKAGE
(BOTTOM VIEW)**

SPECIFICATIONS

Model:	AVO-9A-C-N-POCC ²
Amplitude:	0 to 200 mA
Allowed load voltage range:	0 to 3V
Pulse width:	0.4 to 4.0 ns
PRF:	0 to 1.0 MHz
Rise time:	≤ 200 ps
Fall time:	≤ 200 ps
Related 50 Ohm model:	AVP-AV-1-C
Propagation delay: (Ext trig in to pulse out)	≤ 50 ns
Jitter: (Ext trig in to pulse out)	± 15 ps
DC offset or bias insertion:	Apply required DC bias current in the range of ± 100 mA to solder terminal on output module.
Sync delay: (sync out to pulse out)	Variable 0 to 200 ns
Sync output: (to 50 Ohms)	+ 3 Volts, 200 ns
Trigger required: (ext trig mode)	+ 5 V (TTL), ≥ 50 ns
Connectors: OUT TRIG, SYNC MONITOR	see diagram for appropriate diode pinout BNC SMA
Power requirements:	120/240 Volts (switchable) 50 - 60 Hz
Dimensions: (H x W x D)	Mainframe: 100 mm x 430 mm x 375 mm (3.9" x 7.5" x 14.8") Output module: 41 mm x 66 mm x 76 mm (1.6" x 2.6" x 3.0")
Chassis material:	Mainframe: anodized aluminum, with blue plastic trim Output module: cast aluminum, blue enamel

INSTALLATION

VISUAL CHECK

After unpacking the instrument, examine to ensure that it has not been damaged in shipment. Visually inspect all connectors, knobs, and handles. Confirm that a power cord, an output module, and a 2 foot coaxial cable are with the instrument. If the instrument has been damaged, file a claim immediately with the company that transported the instrument.

PLUGGING IN THE INSTRUMENT

Examine the rear of the instrument. There will be a male power receptacle, a fuse holder and the edge of the power selector card visible. Confirm that the power selector card is in the correct orientation.

For AC line voltages of 110-120V, the power selector card should be installed so that the "120" marking is visible from the rear of the instrument, as shown below:

For AC line voltages of 220-240V, the power selector card should be installed so that the "240" marking is visible from the rear of the instrument, as shown below:

If it is not set for the proper voltage, remove the fuse and then grasp the card with a pair of pliers and remove it. Rotate horizontally through 180 degrees. Reinstall the card and the correct fuse.

In the 120V setting, a 0.5A slow blow fuse is required. In the 240V setting, a 0.25A slow blow fuse is required.

FRONT PANEL CONTROLS

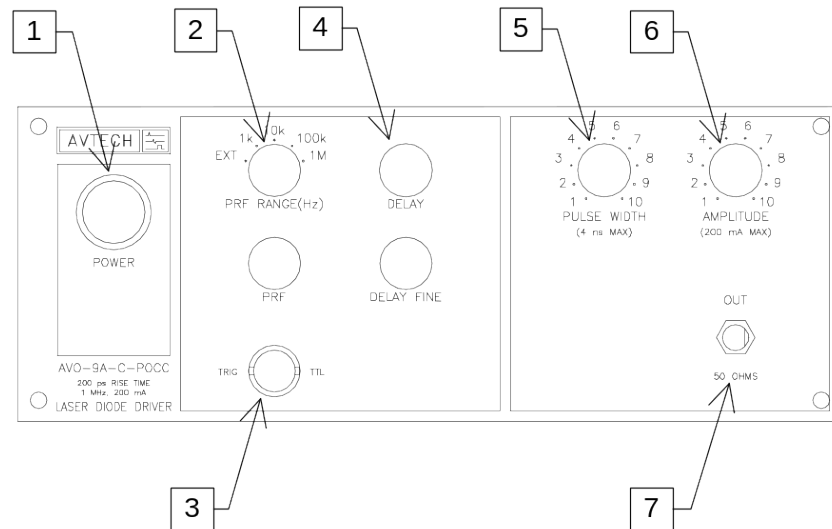

1. POWER Switch. The POWER push button switch applies AC prime power to the primaries of the transformer, turning the instrument on. The push button lamp is connected to the internal +15V DC supply.
2. PRF Range Switch. This switch sets the pulse repetition frequency (PRF) range of the internal oscillator. The marked value of each position is the upper limit of the 10:1 range, approximately. The vernier dial directly below the switch varies the PRF within the set range.

If this switched is set to the “EXT” position, the instrument is triggered by a signal applied to the TRIG connector, rather than by the internal oscillator.

3. TRIG Connector. When the PRF Range Switch is set to “EXT”, the instrument is triggered by a TTL pulse applied to this connector. The pulse must be at least 50 ns wide.

When the PRF Range Switch is set to one of the four internal oscillator ranges, this connector is an output, which supplies a 3V, 200 ns wide pulse for each trigger event. This output may be used to trigger oscilloscopes or other equipment.

4. Delay Controls. When the PRF Range Switch is set to one of the four internal oscillator ranges, the main output is delayed relative to the TRIG output pulse (item 3). The delay is variable up to 200 ns, approximately, using the DELAY and DELAY FINE dials.
5. Pulse Width Control. This dial controls the pulse width.

6. Amplitude Control. This dial controls the pulse amplitude.
7. OUT Connector. This SMA connector is connected to the output module, when the output module is used to drive a diode load. If the output module is not used, this output will generate up to 10V into a load impedances of 50Ω. (NOTE: when the output module is not used, this output *requires* a 50Ω load to function properly).

REAR PANEL CONTROLS

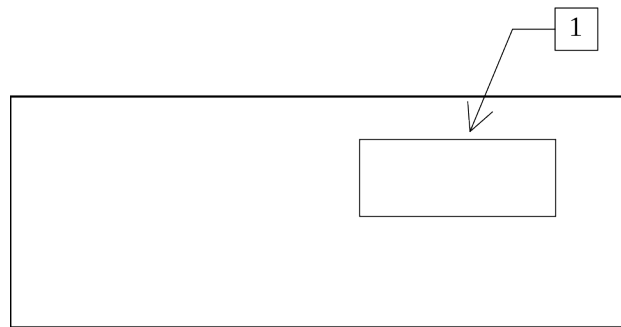

1. AC POWER INPUT. A three-pronged recessed male connector is provided on the back panel for AC power connection to the instrument. Also contained in this assembly is a slow-blow fuse and a removable card that can be removed and repositioned to switch between 120V AC in and 240V AC in.

For AC line voltages of 110-120V, the power selector card should be installed so that the “120” marking is visible from the rear of the instrument.

For AC line voltages of 220-240V, the power selector card should be installed so that the “240” marking is visible from the rear of the instrument.

If it is not set for the proper voltage, remove the fuse and then grasp the card with a pair of pliers and remove it. Rotate horizontally through 180 degrees. Reinstall the card and the correct fuse.

In the 120V setting, a 0.5A slow blow fuse is required. In the 240V setting, a 0.25A slow blow fuse is required. See the “Installation” section for more details.

GENERAL INFORMATION

MINIMAL TEST ARRANGEMENT - WITHOUT OUTPUT MODULE

The AVO-9A-C-N-POCC can be tested initially without the supplied output module. If the output module is not used, the mainframe output generates 0 to -12V into a 50 Ohm load, as illustrated below:

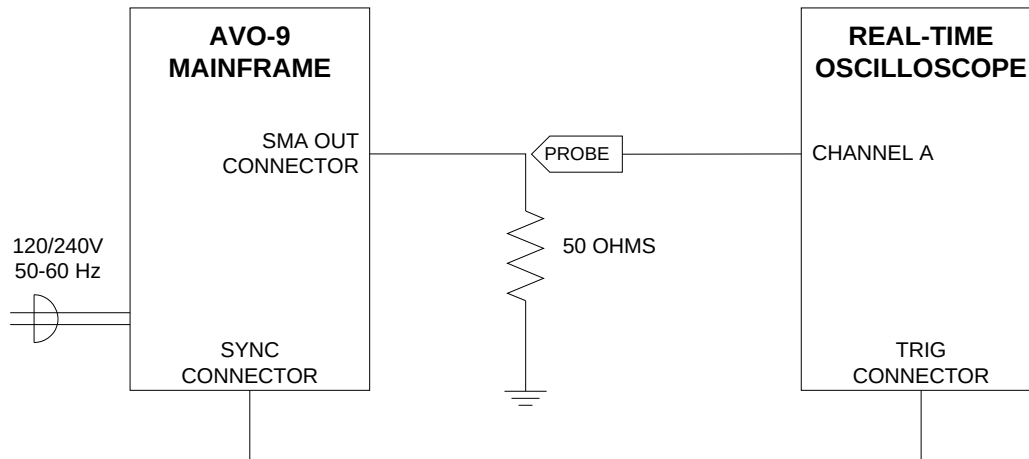

Since the AVO-9A-C-N-POCC can generate pulses with rise times as low as 200 ps, it may be necessary to use a sampling oscilloscope, rather than a real-time oscilloscope. In this case, the test arrangement should be altered as shown below:

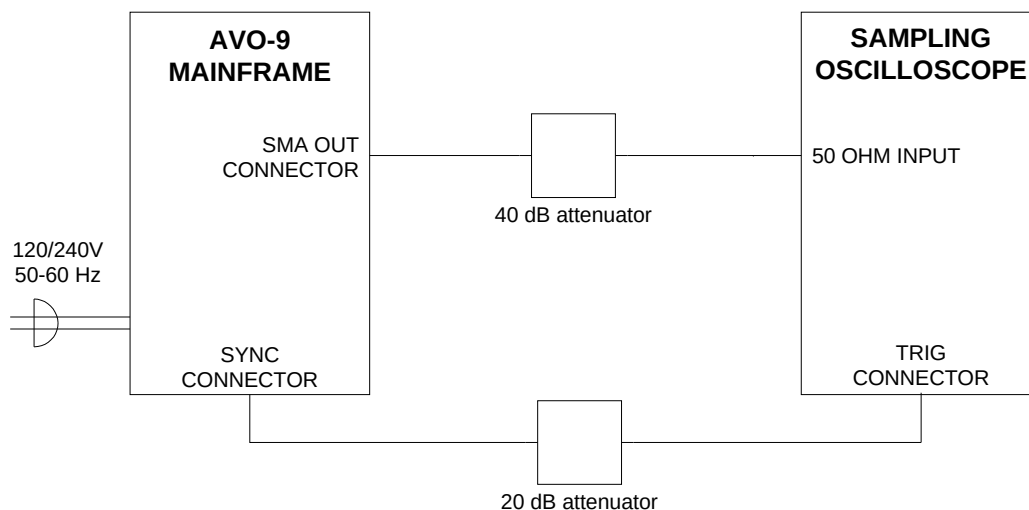

Since most sampling oscilloscopes have limited input amplitude ranges, attenuators are required.

When the output module is not used, a 50 Ohm load impedance is *required* for proper test operation.

NORMAL TEST ARRANGEMENT

To fully test the instrument, and for normal operation, the output module must be connected as shown below:

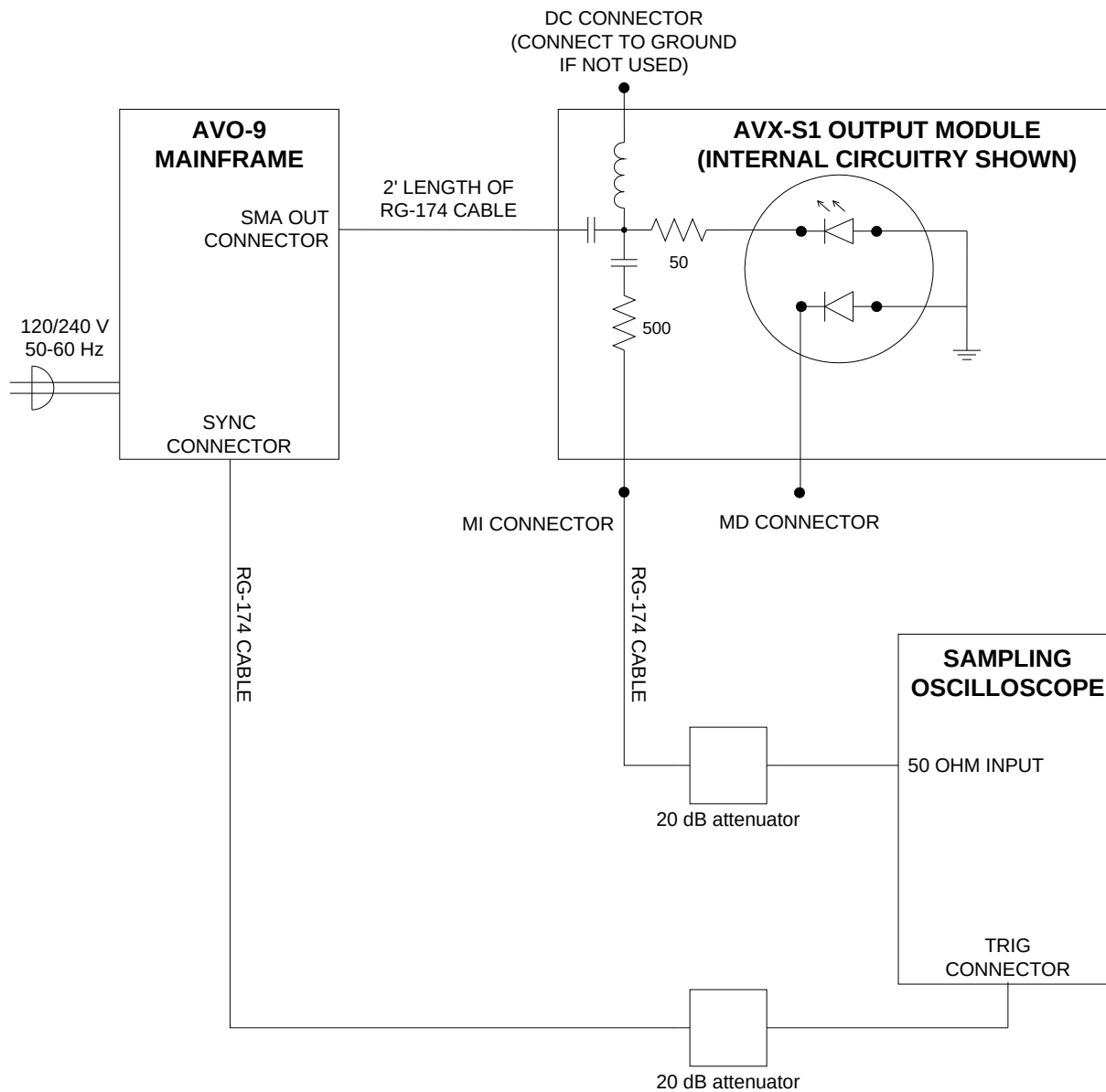

The diode load is inserted into the socket on the output module. The mechanical layout of the socket is shown below:

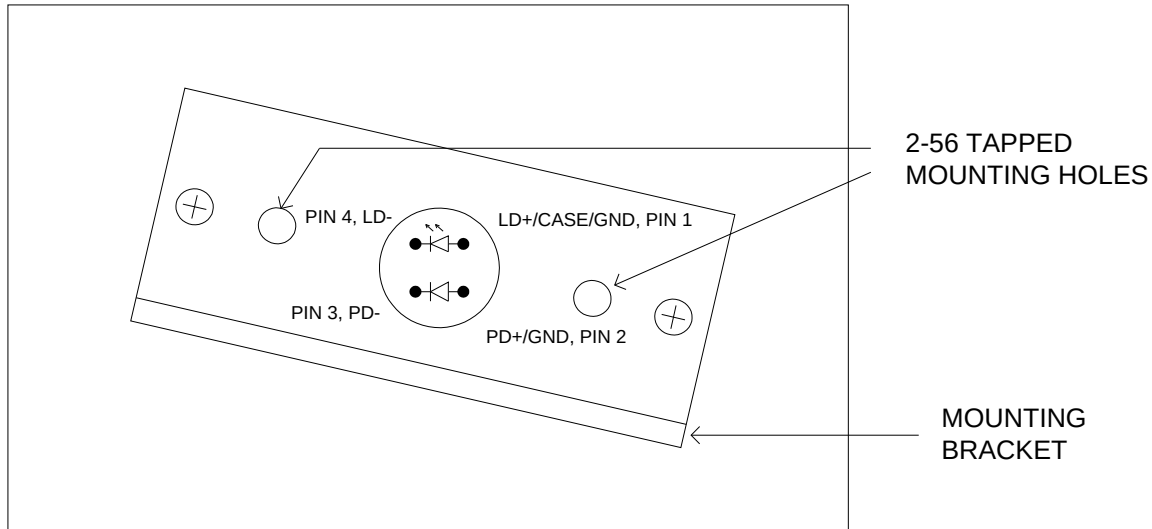

AVX-S1 OUTPUT MODULE, SOCKET VIEW

NOTE: Please note that care must be taken to insert the diode in the correct orientation. It is possible to insert it incorrectly, which may cause damage to the diode and the output module. If a diode with a mounting flange is used, the output module mounting bracket will align the diode into one of two orientations. Select the one correct orientation by making sure that the diode pin that is welded directly to the diode case (pin 1) is oriented upwards.

An oscilloscope may be used to monitor the MI and MD outputs, the locations of which are shown in the figure below. A forward DC bias may be applied to the laser diode by connecting a DC potential of 0 to -5 Volts to the DC solder terminal. The application of a small forward bias often yields a more ideal diode current waveform (as observed on the MI port). Note that the DC port must be shorted to ground if a bias is not applied.

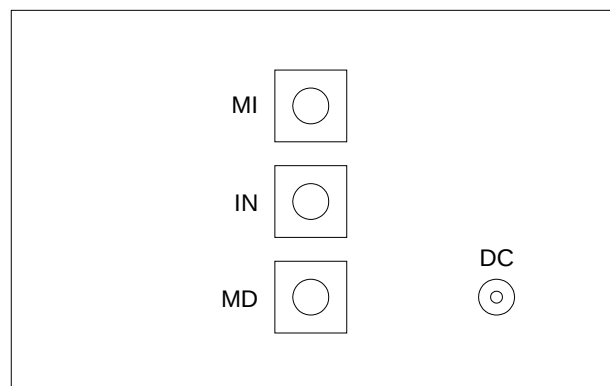

AVX-S1 OUTPUT MODULE, CONNECTOR VIEW

AMPLITUDE CONTROL

When using the output module, the pulse current through the diode load is given by:

$$I_{DIODE} = \frac{V_{SET} - V_{DIODE}}{50\Omega}$$

where V_{SET} is the amplitude setting on the mainframe (between 0 and 12V), and V_{DIODE} is the forward voltage drop across the diode (typically 2 or 3V).

BASIC PULSE CONTROL

This instrument can be triggered by its own internal clock or by an external TTL trigger signal. When triggered internally, two mainframe output channels respond to the trigger: OUT and SYNC.

- OUT. This is the main output. The maximum output voltage is 12V.
- TRIG. The TRIG pulse is a fixed-width TTL-level reference pulse used to trigger oscilloscopes or other measurement systems.

These pulses are illustrated below:

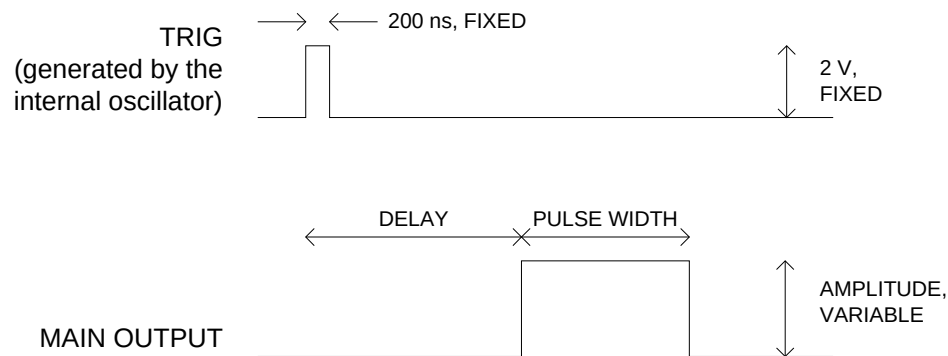

Figure A

When triggered externally, the TRIG connector acts as an input. The delay controls do not function in this mode.

PULSE WIDTH / AMPLITUDE INTERACTION

The pulse width and delay of the output pulse may vary slightly with the amplitude setting, particularly at lower amplitudes. For some demanding applications, it may be desirable to use external attenuators in conjunction with the AVO-9A-C-N-POCC, instead of generating a low-amplitude pulse directly.

TOP COVER REMOVAL

The interior of the instrument may be accessed by removing the four Phillips screws on the top panel. With the four screws removed, the top cover may be slid back (and off).

ELECTROMAGNETIC INTERFERENCE

To prevent electromagnetic interference with other equipment, all used outputs should be connected to shielded 50 Ω loads using shielded 50 Ω coaxial cables. Unused outputs should be terminated with shielded 50 Ω BNC terminators or with shielded BNC dust caps, to prevent unintentional electromagnetic radiation. All cords and cables should be less than 3m in length.

RACK MOUNTING

A rack mounting kit is available. The -R5 rack mount kit may be installed after first removing the one Phillips screw on the side panel adjacent to the front handle.

PROTECTING YOUR INSTRUMENT

DO NOT EXCEED 1 MHz

The output stage may be damaged if triggered by an external signal at a pulse repetition frequency greater than 1 MHz.

USE A 50Ω LOAD

The mainframe output stage may be damaged if the output is not terminated into the output module or a 50Ω dummy load.

INSTALL THE DIODE CORRECTLY

The output module accommodates only one diode pinout. Please see the previous sections for more details. Installing the incorrect diode, or installing the correct diode in the incorrect orientation may damage both the diode or the output module.

PERFORMANCE CHECKSHEET