

INSTRUCTIONS

MODEL AVOZ-A2-PS-AT-PWT PULSE GENERATOR

S.N.:

WARRANTY

Avtech Electrosystems Ltd. warrants products of its manufacture to be free from defects in material and workmanship under conditions of normal use. If, within one year after delivery to the original owner, and after prepaid return by the original owner, this Avtech product is found to be defective, Avtech shall at its option repair or replace said defective item. This warranty does not apply to units which have been disassembled, modified or subjected to conditions exceeding the applicable specifications or ratings. This warranty is the extent of the obligation assumed by Avtech with respect to this product and no other warranty or guarantee is either expressed or implied.

TECHNICAL SUPPORT

Phone: 613-226-5772 or 1-800-265-6681

Fax: 613-226-2802 or 1-800-561-1970

E-mail: info@avtechpulse.com

World Wide Web: <http://www.avtechpulse.com>

TABLE OF CONTENTS

WARRANTY.....	2
TABLE OF CONTENTS.....	4
FIG. 1: PULSE GENERATOR TEST ARRANGEMENT.....	5
GENERAL OPERATING INSTRUCTIONS.....	6
FIG. 2: FRONT PANEL CONTROLS.....	8
FRONT PANEL CONTROLS.....	9
FIG. 3: BACK PANEL CONTROLS.....	10
BACK PANEL CONTROLS.....	11
POWER SUPPLY AND FUSE REPLACEMENT.....	12
PERFORMANCE CHECK SHEET.....	14

FIG. 1: PULSE GENERATOR TEST ARRANGEMENT

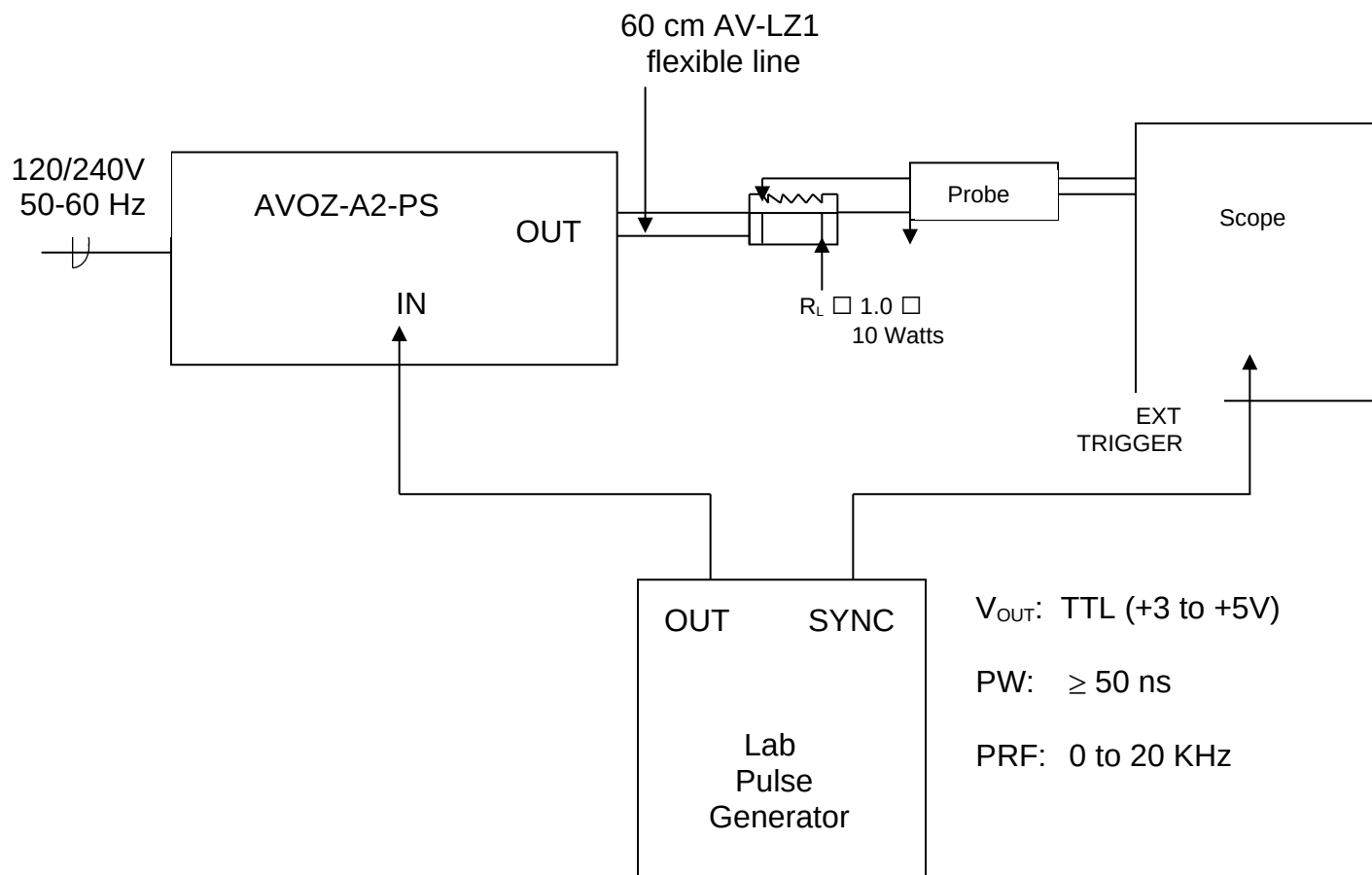

GENERAL OPERATING INSTRUCTIONS

- 1) The equipment should be connected in the general fashion shown above. Since the unit provides an output pulse rise time as low as 100 ns a fast oscilloscope (at least 50 MHz and preferably 200 MHz) should be used to display the waveform. The load current may be deduced if the resistance and load voltage are known. Alternatively, the output current may be monitored using a current probe.

- 2) The output terminals of the pulse generator consists of a 60 cm length of 1 Ohm microstrip transmission line protruding from the front panel. The flexible line is terminated in a 0.5" x 0.5" x 1/16" PCB board to which the load may be soldered. The AV-LZ1 line plugs into the front panel "OUT" PCB edge connector.

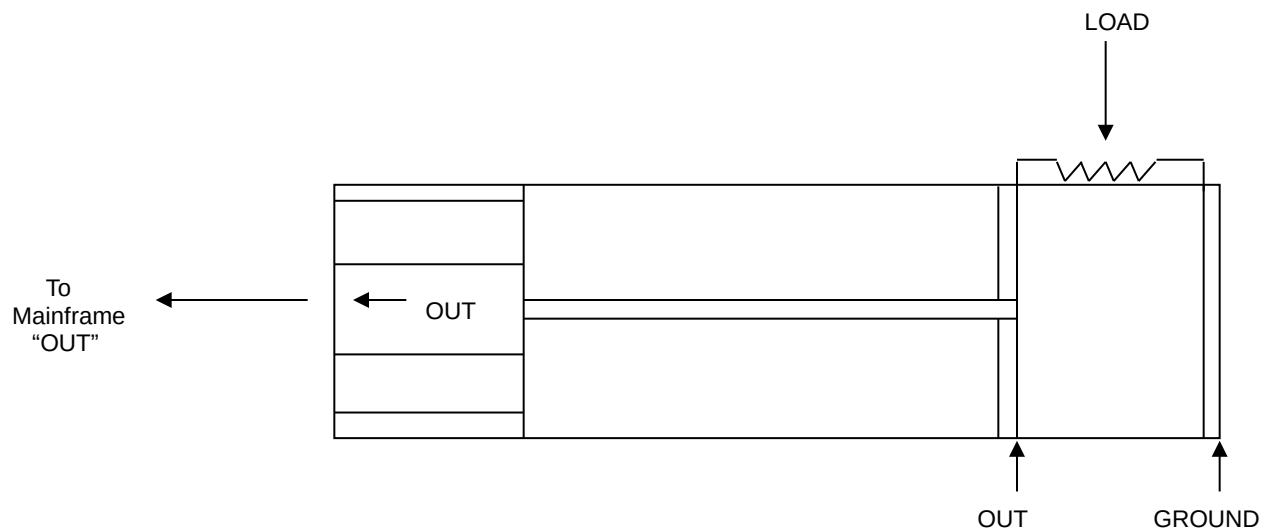

Note that the load should be greater than 1.0 Ohms (10 Watts).

The load should be connected between the OUT and GND terminals using very short leads (≤ 0.5 cm). Longer leads introduce inductance which will result in spikes and overshoot on the leading and falling edge of the load voltage waveform.

- 3) **CAUTION:** The AVOZ unit is designed to provide 0 to +50 Volt pulses to a load resistance of 1.0 Ohms (or higher). The maximum load current is 50 Amps. Insure that the load can dissipate up to 2.5 KW peak power and 10 Watts average power.
- 4) The output pulse width is controlled by means of the front panel ten-turn PW control. To voltage control the pulse width, set the rear panel switch in the EXT position and apply 0 to +10 Volts between terminal A and ground ($R_{IN} \geq 10K$). (option)
- 5) The output amplitude is controlled by the ten-turn amplitude control.
- 6) The output pulse repetition frequency equals the TTL input trigger pulse repetition frequency.
- 7) **CAUTION.** When setting the pulse width and pulse repetition frequency, take care to insure that the duty cycle does not exceed 0.4% (eg. For a pulse width of 1 us, the PRF must not exceed 4 KHz).
- 8) AVOZ units with a serial number higher than 5600 are protected by an automatic overload protective circuit, which controls the front panel overload light. If the unit is overloaded (by operating at an exceedingly high duty cycle or by operating into a short circuit), the protective circuit will turn the output of the instrument OFF and turn the indicator light ON. The light will stay ON (i.e. output OFF) for about 5 seconds after which the instrument will attempt to turn ON (i.e. light OFF) for about 1 second. If the overload condition persists, the instrument will turn OFF again (i.e. light ON) for another 5 seconds. If the overload condition has been removed, the instrument will turn on and resume normal operation. Overload conditions may be removed by:
 - 1) Reducing PRF (i.e. switch to a lower range)
 - 2) Reducing pulse width (i.e. switch to a lower range)
 - 3) Increase the load resistance.
- 9) The unit can be converted from 120 to 240V 50-60 Hz operation by adjusting the voltage selector card in the rear panel fused voltage selector cable connector assembly.
- 10) For additional assistance:

Tel: (613) 226-5772
Fax: (613) 226-2802
Email: info@avtechpulse.com

FIG. 2: FRONT PANEL CONTROLS

FRONT PANEL CONTROLS

- i. ON-OFF Switch. Applies basic prime power to all stages.
- ii. IN. BNC connector to which the TTL trigger pulse ($PW \geq 50$ ns) is applied.
- iii. AMPLITUDE. A ten-turn control for varying the output amplitude from 0 to 50 Volts (to $R_L \leq 1$ Ohms) (50 Amps max).
- iv. PW CONTROL. A ten-turn control which varies the output pulse width from 20 ns to 1 us.
- v. OUT. 1 Ohm flexible microstrip output line terminated in a 0.5" x 0.5" x 1/16" circuit board connects to this plug in connection. The load is solder connected to the PCB board. Ideally the load should be ≤ 1.0 Ohms with a very low inductance component.
- vi. OVERLOAD. AVOZ units with a serial number higher than 5600 are protected by an automatic overload protective circuit which controls the front panel overload light. If the unit is overloaded (by operating at an exceedingly high duty cycle or by operating into a short circuit), the protective circuit will turn the output of the instrument OFF and turn the indicator light ON. The light will stay ON (i.e. output OFF) for about 5 seconds after which the instrument will attempt to turn ON (i.e. light OFF) for about 1 second. If the overload condition persists, the instrument will turn OFF again (i.e. light ON) for another 5 seconds. If the overload condition has been removed, the instrument will turn on and resume normal operation. Overload conditions may be removed by:
 1. Reducing PRF
 2. Reducing pulse width
 3. Increase load resistance

FIG. 3: BACK PANEL CONTROLS

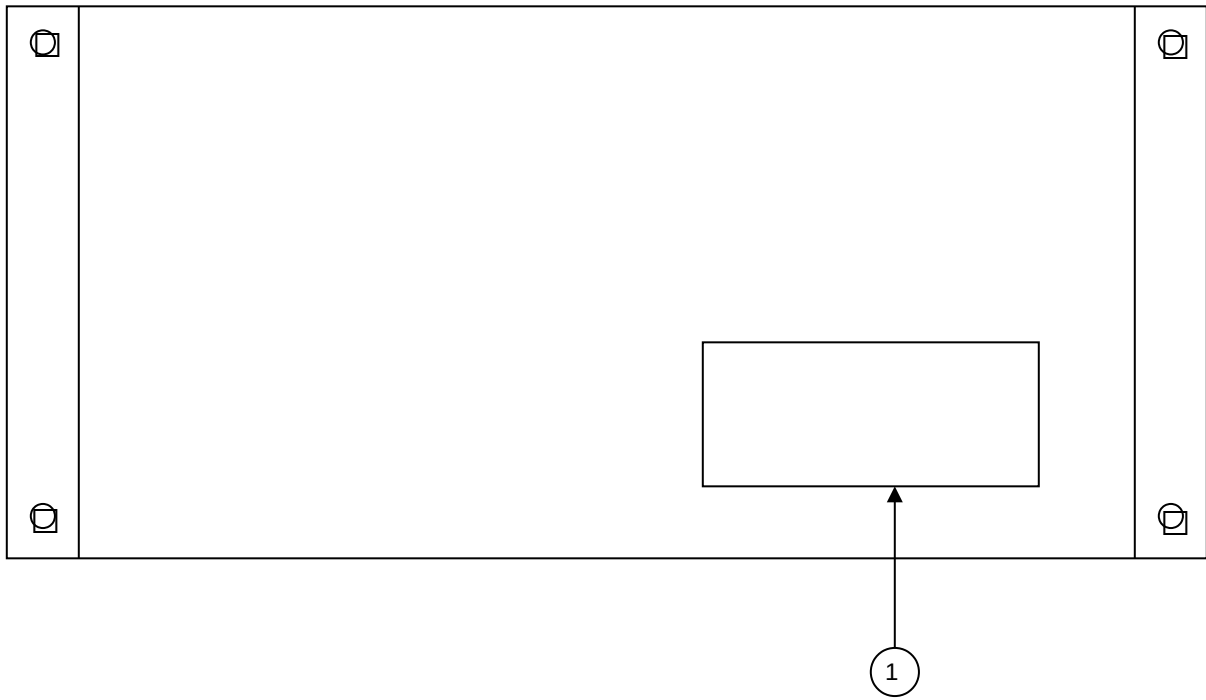

BACK PANEL CONTROLS

- (1) FUSED CONNECTOR, VOLTAGE SELECTOR. The detachable power cord is connected at this point. In addition, the removable cord is adjusted to select the desired input operating voltage. The unit also contains the main power fuse.

For AC line voltages of 110-120V, the power selector card should be installed so that the "120" marking is visible from the rear of the instrument.

For AC line voltages of 220-240V, the power selector card should be installed so that the "240" marking is visible from the rear of the instrument.

If it is not set for the proper voltage, remove the fuse and then grasp the card with a pair of pliers and remove it. Rotate horizontally through 180 degrees. Reinstall the card and the correct fuse.

In the 120V setting, a 0.5A slow blow fuse is required. In the 240V setting, a 0.25A slow blow fuse is required.

POWER SUPPLY AND FUSE REPLACEMENT

This instrument has three main fuses, plus two spares. One, which protects the AC input, is located in the rear-panel power entry module, as described in the “Rear Panel Controls” section of this manual. If the power appears to have failed, check the AC fuse first.

The other two fuses (plus two spares) are located on the internal DC power supply, as shown below:

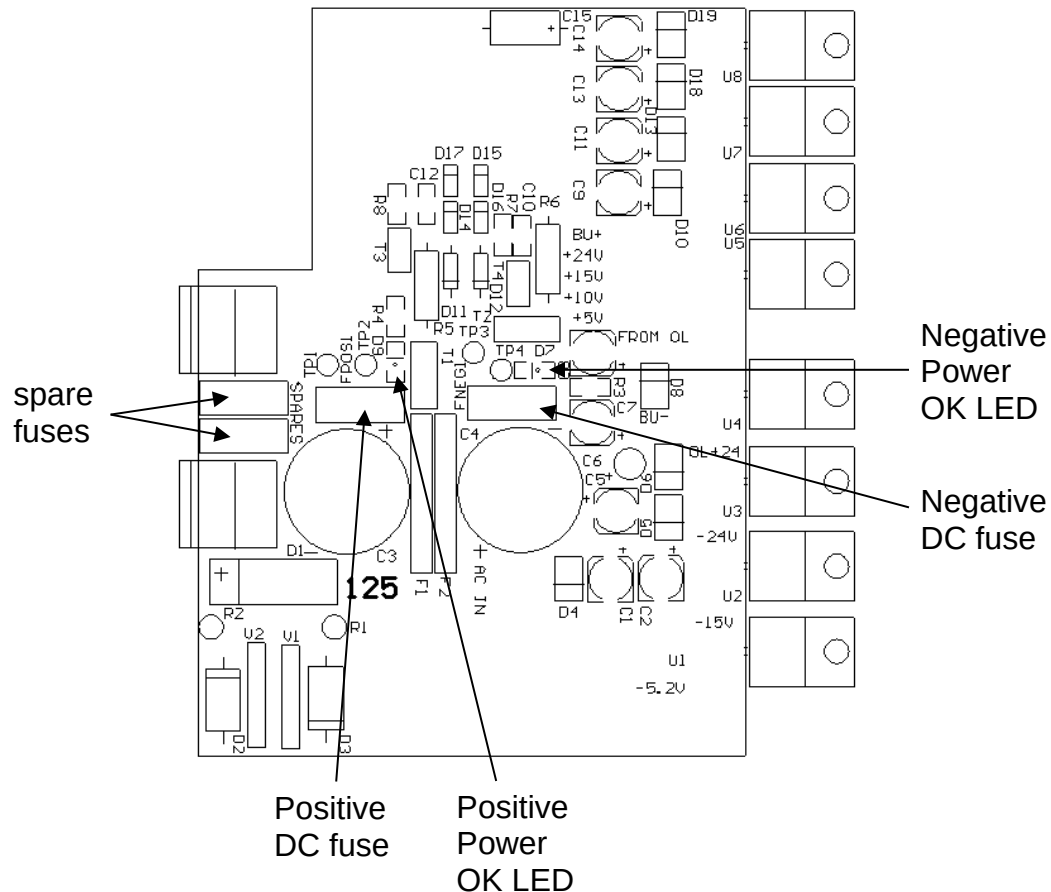

The positive fuse and one of the spare fuses on this circuit board are 1A slow-blow fuses, Littlefuse part number R452001. (This fuse can be ordered from Digikey, www.digikey.com. The Digikey part number is F1343CT-ND). The negative fuse and the second spare fuse are 0.5A slow-blow fuses (Littlefuse R452.500, Digikey part number F1341CT-ND).

If you suspect that the DC fuses are blown, follow this procedure:

1. Remove the top cover, by removing the four Phillips screws on the top cover and then sliding the cover back and off.
2. Locate the two "Power OK" LEDs on the power supply circuit board, as illustrated above.
3. Turn on the instrument.
4. Observe the "Power OK" LEDs. If the fuses are not blown, the two LEDs will be lit (bright red). If one of the LEDs is not lit, the fuse next to it has blown.
5. Turn off the instrument.
6. If a fuse is blown, use needle-nose pliers to remove the blown fuse from its surface-mount holder.
7. Replace the fuse. (Spare 1 Amp and 0.5 Amp fuses are provided on the circuit board. They may be transferred to the active fuse locations using needle-nose pliers.)

PERFORMANCE CHECK SHEET