



AVTECH ELECTROSYSTEMS LTD.

NANOSECOND WAVEFORM ELECTRONICS
SINCE 1975

P.O. BOX 265
OGDENSBURG, NY
U.S.A. 13669-0265
TEL: (315) 472-5270
FAX: (613) 226-2802

TEL: 1-800-265-6681
FAX: 1-800-561-1970

e-mail: info@avtechpulse.com
<http://www.avtechpulse.com/>

BOX 5120, LCD MERIVALE
OTTAWA, ONTARIO
CANADA K2C 3H4
TEL: (613) 226-5772
FAX: (613) 226-2802

INSTRUCTIONS

MODEL AVOZ-A3-B

0 to 100 AMP, 0 to 100 V, 30 ns RISE TIME
LASER DIODE DRIVER
WITH IEEE 488.2 AND RS-232 CONTROL

SERIAL NUMBER: _____

WARRANTY

Avtech Electrosystems Ltd. warrants products of its manufacture to be free from defects in material and workmanship under conditions of normal use. If, within one year after delivery to the original owner, and after prepaid return by the original owner, this Avtech product is found to be defective, Avtech shall at its option repair or replace said defective item. This warranty does not apply to units which have been disassembled, modified or subjected to conditions exceeding the applicable specifications or ratings. This warranty is the extent of the obligation assumed by Avtech with respect to this product and no other warranty or guarantee is either expressed or implied.

TECHNICAL SUPPORT

Phone: 613-226-5772 or 1-800-265-6681

Fax: 613-226-2802 or 1-800-561-1970

E-mail: info@avtechpulse.com

World Wide Web: <http://www.avtechpulse.com>

TABLE OF CONTENTS

WARRANTY.....	2
TECHNICAL SUPPORT.....	2
TABLE OF CONTENTS.....	3
INTRODUCTION.....	5
SPECIFICATIONS.....	6
EC DECLARATION OF CONFORMITY.....	7
INSTALLATION.....	8
VISUAL CHECK.....	8
POWER RATINGS.....	8
CONNECTION TO THE POWER SUPPLY.....	8
ENVIRONMENTAL CONDITIONS.....	8
LABVIEW DRIVERS.....	9
FUSES.....	10
AC FUSE REPLACEMENT.....	10
DC FUSE REPLACEMENT.....	11
FUSE RATINGS.....	11
FRONT PANEL CONTROLS.....	12
REAR PANEL CONTROLS.....	14
GENERAL INFORMATION - PULSE GENERATOR TIMING.....	16
BASIC PULSE CONTROL.....	16
TRIGGER MODES.....	17
GATING MODES.....	17
GENERAL INFORMATION - OPERATING INTO A LOAD.....	19
AMPLITUDE CONTROL.....	19
TEST ARRANGEMENT.....	19
USING THE LZ OUTPUT LINE.....	20
LENZ'S LAW AND INDUCTIVE VOLTAGE SPIKES.....	20
ATTACHING AND DETACHING LOADS.....	21
START-UP CHECK-LIST FOR LOCAL CONTROL.....	22
MECHANICAL INFORMATION.....	24
TOP COVER REMOVAL.....	24
RACK MOUNTING.....	24
ELECTROMAGNETIC INTERFERENCE.....	24

MAINTENANCE..... 25
 REGULAR MAINTENANCE..... 25
 CLEANING..... 25
CALIBRATION ADJUSTMENTS - SOFTWARE PROCEDURES.....26
 ADJUSTING AMPLITUDE ACCURACY.....26
PROGRAMMING YOUR PULSE GENERATOR.....27
 KEY PROGRAMMING COMMANDS.....27
 ALL PROGRAMMING COMMANDS.....28
PERFORMANCE CHECK SHEET..... 30

Manual Reference: /fileserv1/officefiles/instructword/avoz/AVOZ-A3-B,edition3.sxw.
Last modified February 29, 2024.
Copyright © 2003 Avtech Electrosystems Ltd, All Rights Reserved.

INTRODUCTION

The Model AVOZ-A3-B pulse generator is designed for pulsing laser diode and other low impedance loads with rectangular pulses as high as 100V into $1\ \Omega$ (i.e. 100 Amps) with 30 ns rise and fall times. The current and voltage polarities depend on the model number:

- P units: 0 to +100 V amplitude (0 to +100 Amps)
- N units: 0 to -100 V amplitude (0 to -100 Amps)
- PN units: 0 to ± 100 V amplitude (0 to ± 100 Amps)

The pulse repetition frequency can vary from 1 Hz to 20 kHz, and pulse widths can vary from 50 ns to 2 μ s. The maximum duty cycle is 0.1%, and the maximum average output power is 10 Watts.

The Model AVOZ-A3-B pulse generator is a voltage pulser. The current amplitude is determined by Ohm's Law. That is, the current is the output voltage divided by the load resistance. The load resistance should be approximately $1\ \Omega$ to attain a peak current of 100 A.

The loads can be connected to the pulse generator using the convenient LZ1 flexible flat transmission line, which has a $1\ \Omega$ characteristic impedance (Z_0), and is terminated with a small circuit board.

The AVOZ-A3-B can be controlled from the front panel, or via a computer connected to the IEEE 488.2-compliant GPIB port, or the RS-232 serial port.

This instrument is intended for use in research and development laboratories.

SPECIFICATIONS

Model ¹ :	AVOZ-A3-B
Amplitude ^{2,3} : current: voltage:	0 to 100A 0 to 100V
Minimum load impedance ⁴ : (required to limit current)	1 Ω
Pulse width (FWHM):	50ns - 2us
Rise time (20%-80%):	\leq 30 ns
Fall time (80%-20%):	\leq 30 ns
Maximum PRF:	20 kHz
Duty cycle: (max)	0.1 %
Output impedance:	\leq 0.05 Ω
Average output power:	10 Watts maximum
Droop:	\leq 5%, at maximum pulse width and maximum amplitude
Polarity ⁵ :	Positive or negative or dual polarity (specify)
GPIO & RS-232 control ¹ :	Standard on -B units.
LabView drivers:	Check http://www.avtechpulse.com/labview for availability and downloads
Propagation delay:	\leq 100 ns (Ext trig in to pulse out)
Jitter:	\leq 100 ps (Ext trig in to pulse out)
Trigger required:	External trigger mode: + 5 Volts, 50 to 500 ns (TTL)
Sync delay: (sync out to pulse out)	Variable 0 to \pm 2 us
Sync output:	+ 3 Volt, 200 ns, will drive 50 Ohm loads
Gate input:	Synchronous or asynchronous, active high or low, switchable. Suppresses triggering when active.
Output transmission line: length: characteristic impedance:	Flexible microstrip, 60 cm 1 Ω
Output connection:	Solder terminals (or optional socket ⁶), on the end of the flexible microstrip transmission line
Other connectors:	Trig, Gate, Sync: BNC
Power requirements:	100 - 240 Volts, 50 - 60 Hz
Dimensions: Mainframe:	100 mm x 430 mm x 375 mm (3.9" x 17" x 14.8")
Output Module:	N/A
Chassis material:	Anodized aluminum, with blue plastic trim
Mounting:	Any
Temperature range:	+5°C to +40°C

- 1) -B suffix indicates IEEE-488.2 GPIO and RS-232 control of pulse amplitude, pulse width, delay and PRF. (See page 8).
- 2) For remote analog electronic control (0 to + 10V) of the amplitude, suffix model number with -EA. Electronic control units also include standard front-panel controls.
- 3) For operation at voltage amplitudes of less than 10% of full-scale, better results may be obtained by setting the amplitude near full-scale and increasing the load impedance accordingly.
- 4) For applications where additional resistance must be added in series with the device under test, Avtech recommends connecting multiple Ohmite OX or OY-series or RCD RSF2B resistors in parallel to create a high-power, low-inductance effective resistance.
- 6) Indicate desired polarity by suffixing model number with -P or -N (i.e. positive or negative) or -PN for dual polarity option.
- 7) To specify diode socket mounting option, suffix model number with -S5 and describe the diode package type (e.g. TO-18) and the required pin connections (eg. anode, cathode, ground, etc.). See page 75 for readily available package mounting. Contact Avtech for special or different packages.

EC DECLARATION OF CONFORMITY

We

Avtech Electrosystems Ltd.
P.O. Box 5120, LCD Merivale
Ottawa, Ontario
Canada K2C 3H4

declare that this pulse generator meets the intent of Directive 89/336/EEC for Electromagnetic Compatibility. Compliance pertains to the following specifications as listed in the official Journal of the European Communities:

EN 50081-1 Emission

EN 50082-1 Immunity

and that this pulse generator meets the intent of the Low Voltage Directive 72/23/EEC as amended by 93/68/EEC. Compliance pertains to the following specifications as listed in the official Journal of the European Communities:

EN 61010-1:2001 Safety requirements for electrical equipment for measurement, control, and laboratory use

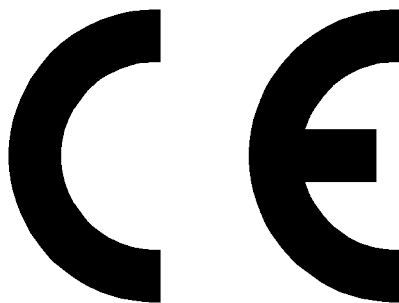

INSTALLATION

VISUAL CHECK

After unpacking the instrument, examine to ensure that it has not been damaged in shipment. Visually inspect all connectors, knobs, liquid crystal displays (LCDs), and the handles. Confirm that a power cord, a GPIB cable, a LZ1 flexible transmission line, and two instrumentation manuals (this manual and the “OP1B Interface Programming Manual”) are with the instrument. If the instrument has been damaged, file a claim immediately with the company that transported the instrument.

POWER RATINGS

This instrument is intended to operate from 100 - 240 V, 50 - 60 Hz.

The maximum power consumption is 90 Watts. Please see the “FUSES” section for information about the appropriate AC and DC fuses.

This instrument is an “Installation Category II” instrument, intended for operation from a normal single-phase supply.

CONNECTION TO THE POWER SUPPLY

An IEC-320 three-pronged recessed male socket is provided on the back panel for AC power connection to the instrument. One end of the detachable power cord that is supplied with the instrument plugs into this socket. The other end of the detachable power cord plugs into the local mains supply. Use only the cable supplied with the instrument. The mains supply must be earthed, and the cable used to connect the instrument to the mains supply must provide an earth connection. (The supplied cable does this.)

ENVIRONMENTAL CONDITIONS

This instrument is intended for use under the following conditions:

1. indoor use;
2. altitude up to 2 000 m;
3. temperature 5 °C to 40 °C;
4. maximum relative humidity 80 % for temperatures up to 31 °C decreasing linearly to 50 % relative humidity at 40 °C;
5. Mains supply voltage fluctuations up to ± 10 % of the nominal voltage;
6. no pollution or only dry, non-conductive pollution.

LABVIEW DRIVERS

A LabVIEW driver for this instrument is available for download on the Avtech web site, at <http://www.avtechpulse.com/labview>. A copy is also available in National Instruments' Instrument Driver Library at <http://www.natinst.com/>.

FUSES

This instrument contains four fuses. All are accessible from the rear-panel. Two protect the AC prime power input, and two protect the internal DC power supplies. The locations of the fuses on the rear panel are shown in the figure below:

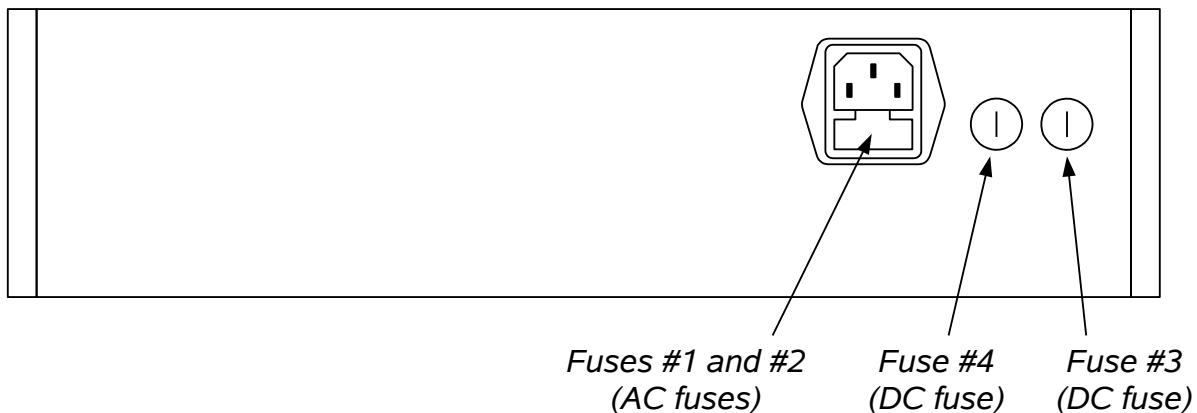

AC FUSE REPLACEMENT

To physically access the AC fuses, the power cord must be detached from the rear panel of the instrument. The fuse drawer may then be extracted using a small flat-head screwdriver, as shown below:

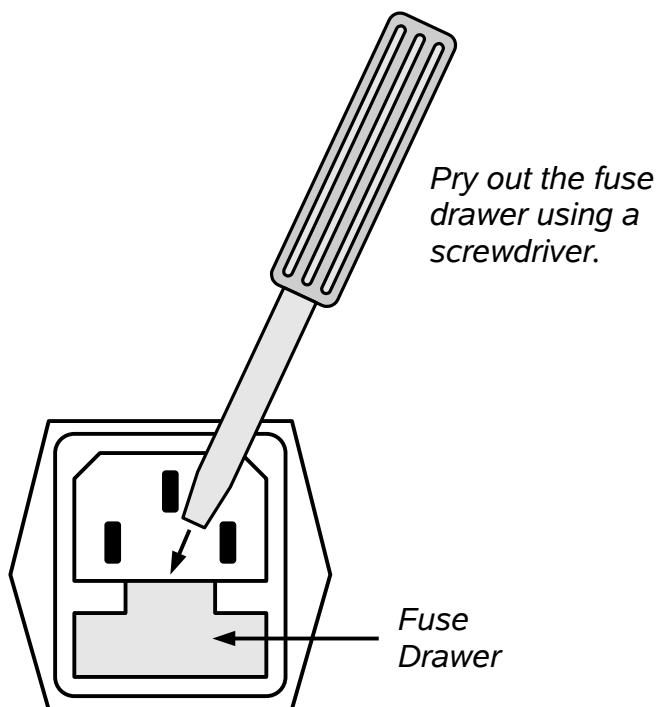

DC FUSE REPLACEMENT

The DC fuses may be replaced by inserting the tip of a flat-head screwdriver into the fuse holder slot, and rotating the slot counter-clockwise. The fuse and its carrier will then pop out.

FUSE RATINGS

The following table lists the required fuses:

Fuses	Nominal Mains Voltage	Rating	Case Size	Manufacturer's Part Number (Wickmann)	Distributor's Part Number (Digi-Key)
#1, #2 (AC)	115 V	0.8A, 250V, Time-Delay	5×20 mm	1950800000	WK5046-ND
	230 V	0.5A, 250V, Time-Delay	5×20 mm	1950500000	WK5041-ND
#3 (DC)	N/A	2.0A, 250V, Time-Delay	5×20 mm	1951200000	WK5057-ND
#4 (DC)	N/A	1.6A, 250V, Time-Delay	5×20 mm	1951160000	WK5053-ND

The fuse manufacturer is Wickmann (<http://www.wickmann.com/>).

Replacement fuses may be easily obtained from Digi-Key (<http://www.digikey.com/>) and other distributors.

FRONT PANEL CONTROLS

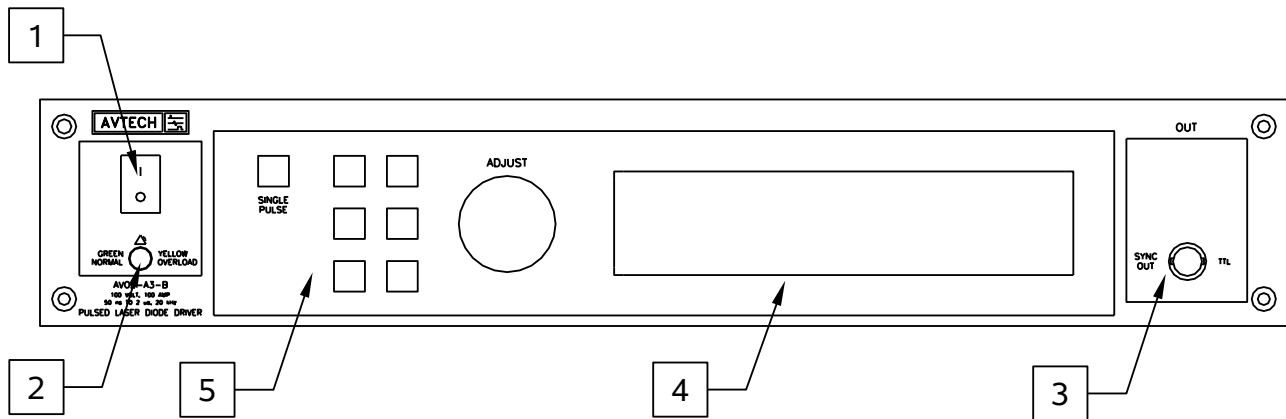

1. POWER Switch. This is the main power switch. When turning the instrument on, there may be a delay of several seconds before the instrument appears to respond.
2. OVERLOAD Indicator. When the instrument is powered, this indicator is normally green, indicating normal operation. If this indicator is yellow, an internal automatic overload protection circuit has been tripped. If the unit is overloaded (by operating at an exceedingly high duty cycle or by operating into a very low impedance), the protective circuit will disable the output of the instrument and turn the indicator light yellow. The light will stay yellow (i.e. output disabled) for about 5 seconds after which the instrument will attempt to re-enable the output (i.e. light green) for about 1 second. If the overload condition persists, the output will be disabled again (i.e. light yellow) for another 5 seconds. If the overload condition has been removed, the instrument will resume normal operation.

This overload indicator may flash yellow briefly at start-up. This is not a cause for concern.

Note that the output stage will safely withstand a short-circuited load condition.

3. SYNC OUT. This connector supplies a SYNC output that can be used to trigger other equipment, particularly oscilloscopes. This signal leads (or lags) the main output by a duration set by the "DELAY" controls and has an approximate amplitude of +3 Volts to $R_L > 1K$ with a pulse width of approximately 50 ns.
4. LIQUID CRYSTAL DISPLAY (LCD). This LCD is used in conjunction with the keypad to change the instrument settings. Normally, the main menu is displayed, which lists the key adjustable parameters and their current values. The "Programming Manual for -B Instruments" describes the menus and submenus in detail.

5. KEYPAD.

Control Name	Function
MOVE	This moves the arrow pointer on the display.
CHANGE	This is used to enter the submenu, or to select the operating mode, pointed to by the arrow pointer.
×10	If one of the adjustable numeric parameters is displayed, this increases the setting by a factor of ten.
÷10	If one of the adjustable numeric parameters is displayed, this decreases the setting by a factor of ten.
+/-	If one of the adjustable numeric parameters is displayed, and this parameter can be both positive or negative, this changes the sign of the parameter.
EXTRA FINE	This changes the step size of the ADJUST knob. In the extra-fine mode, the step size is twenty times finer than in the normal mode. This button switches between the two step sizes.
ADJUST	This large knob adjusts the value of any displayed numeric adjustable values, such as frequency, pulse width, etc. The adjust step size is set by the "EXTRA FINE" button. When the main menu is displayed, this knob can be used to move the arrow pointer.

REAR PANEL CONTROLS

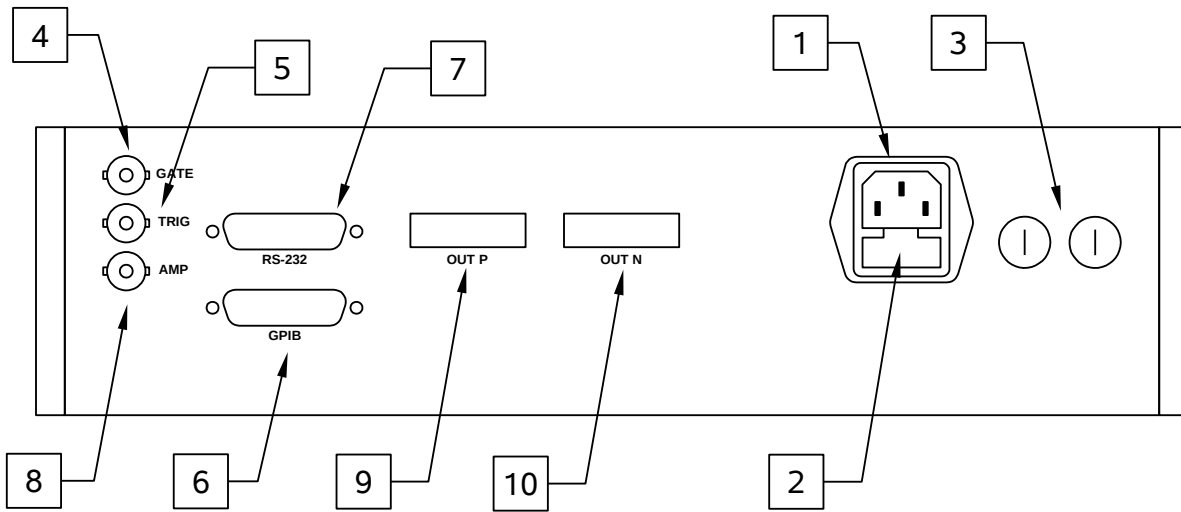

1. AC POWER INPUT. An IEC-320 C14 three-pronged recessed male socket is provided on the back panel for AC power connection to the instrument. One end of the detachable power cord that is supplied with the instrument plugs into this socket.
2. AC FUSE DRAWER. The two fuses that protect the AC input are located in this drawer. Please see the “FUSES” section of this manual for more information.
3. DC FUSES. These two fuses protect the internal DC power supplies. Please see the “FUSES” sections of this manual for more information.
4. GATE. This TTL-level (0 and +5V) logic input can be used to gate the triggering of the instrument. This input can be either active high or active low, depending on the front panel settings or programming commands. (The instrument triggers normally when this input is unconnected). When set to active high mode, this input is pulled-down to ground by a 1 k Ω resistor. When set to active low mode, this input is pulled-up to +5V by a 1 k Ω resistor.
5. TRIG. This TTL-level (0 and +5V) logic input can be used to trigger the instrument, if the instrument is set to triggering externally. The instrument triggers on the rising edge of this input. The input impedance of this input is 1 k Ω . (Depending on the length of cable attached to this input, and the source driving it, it may be desirable to add a coaxial 50 Ohm terminator to this input to provide a proper transmission line termination. The Pasternack (www.pasternack.com) PE6008-50 BNC feed-thru 50 Ohm terminator is suggested for this purpose.)

When triggering externally, the instrument can be set such that the output pulse width tracks the pulse width on this input, or the output pulse width can be set independently.

6. GPIB Connector. A standard GPIB cable can be attached to this connector to allow the instrument to be computer-controlled. See the “Programming Manual for -B Instruments” for more details on GPIB control.
7. RS-232 Connector. A standard serial cable with a 25-pin male connector can be attached to this connector to allow the instrument to be computer-controlled. See the “Programming Manual for -B Instruments” for more details on RS-232 control.
8. AMP Connector. (Active on units with the -EA option only.) The output amplitude can be set to track the voltage on this input. Zero Volts in corresponds to zero amplitude output, and +10V in corresponds to maximum amplitude out. This mode is activated by selecting "Ext Control" on the front-panel amplitude menu, or with the "source:voltage external" command.
9. OUT P. This is the main positive output, present on “-P” and “-PN” units. It is only active when the amplitude is set to a positive value. The LZ1 transmission line plugs into this socket. The upper side of the socket (“UP”) is the signal line. The lower side (“DOWN”) is connected to ground.
10. OUT N. This is the main negative output, present on “-N” and “-PN” units. It is only active when the amplitude is set to a negative value. The LZ1 transmission line plugs into this socket. The upper side of the socket (“UP”) is the signal line. The lower side (“DOWN”) is connected to ground.

GENERAL INFORMATION - PULSE GENERATOR TIMING

BASIC PULSE CONTROL

This instrument can be triggered by its own internal clock or by an external TTL trigger signal. In either case, two output channels respond to the trigger: OUT and SYNC. The OUT channel is the signal that is applied to the device under test. Its amplitude and pulse width are variable. The SYNC pulse is a fixed-width TTL-level reference pulse used to trigger oscilloscopes or other measurement systems. When the delay is set to a positive value the SYNC pulse precedes the OUT pulse.

In the diagrams below, positive amplitude is assumed. (For “-N” units, the output waveforms are inverted in polarity.)

These pulses are illustrated below for a positive delay, and internal triggering:

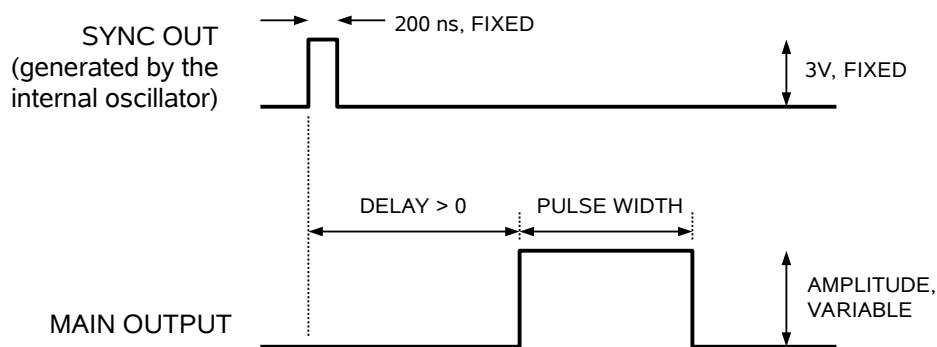

Basic Output Pulses for Delay > 0

The order of the output pulses is reversed for negative delays:

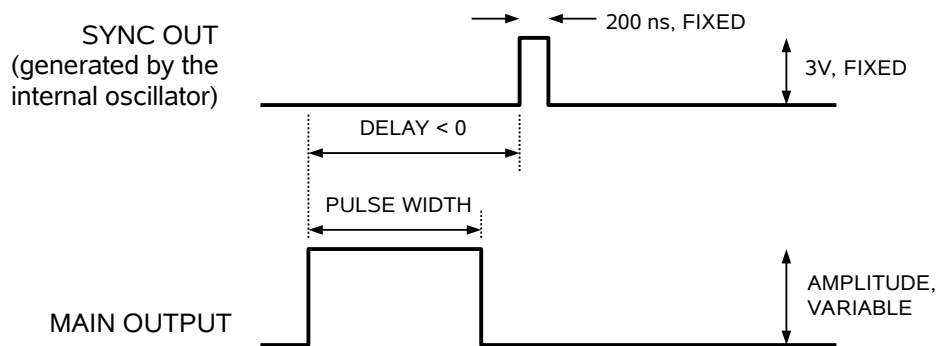

Basic Output Pulses for Delay < 0

When the triggering is set to external mode, a TTL-level pulse on the TRIG input will trigger the pulse generator, as shown below:

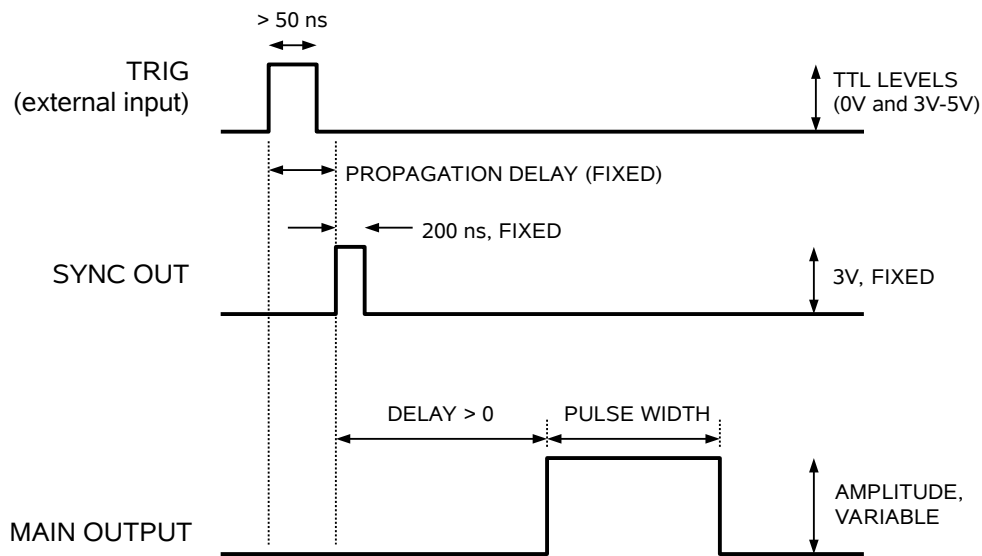

As before, if the delay is negative, the order of the SYNC and OUT pulses is reversed.

TRIGGER MODES

This instrument has four trigger modes:

- Internal Trigger: the instrument controls the trigger frequency, and generates the clock internally.
- External Trigger: the instrument is triggered by an external TTL-level clock on the back-panel TRIG connector.
- Manual Trigger: the instrument is triggered by the front-panel “SINGLE PULSE” pushbutton.
- Hold Trigger: the instrument is set to not trigger at all.

These modes can be selected using the front panel trigger menu, or by using the appropriate programming commands. (See the “OP1B Interface Programming Manual” for more details.)

GATING MODES

Triggering can be suppressed by a TTL-level signal on the rear-panel GATE connector. The instrument can be set to stop triggering when this input high or low, using the front-panel gate menu or the appropriate programming commands. This input can also be set to act synchronously or asynchronously. When set to asynchronous mode, the GATE will disable the output immediately. Output pulses may be truncated. When set to

synchronous mode, the output will complete the full pulse width if the output is high, and then stop triggering. No pulses are truncated in this mode.

GENERAL INFORMATION - OPERATING INTO A LOAD

AMPLITUDE CONTROL

The Model AVOZ-A3-B pulse generator is a voltage pulser. The current amplitude is determined by Ohm's Law. That is, the current is the output voltage divided by the load resistance. More specifically:

$$I_{OUT} = (V_{SETTING} - V_{DIODE}) / R,$$

where $V_{SETTING}$ is the set amplitude, V_{DIODE} is the diode voltage, and R is the series resistance (including any series resistance in the diode itself). R is normally $1\ \Omega$; it should not be smaller than this. Avtech recommends connecting multiple Ohmite OX or OY-series or RCD RSF2B resistors in parallel to create a high-power, low-inductance effective resistance.

TEST ARRANGEMENT

The recommended test arrangement is shown below:

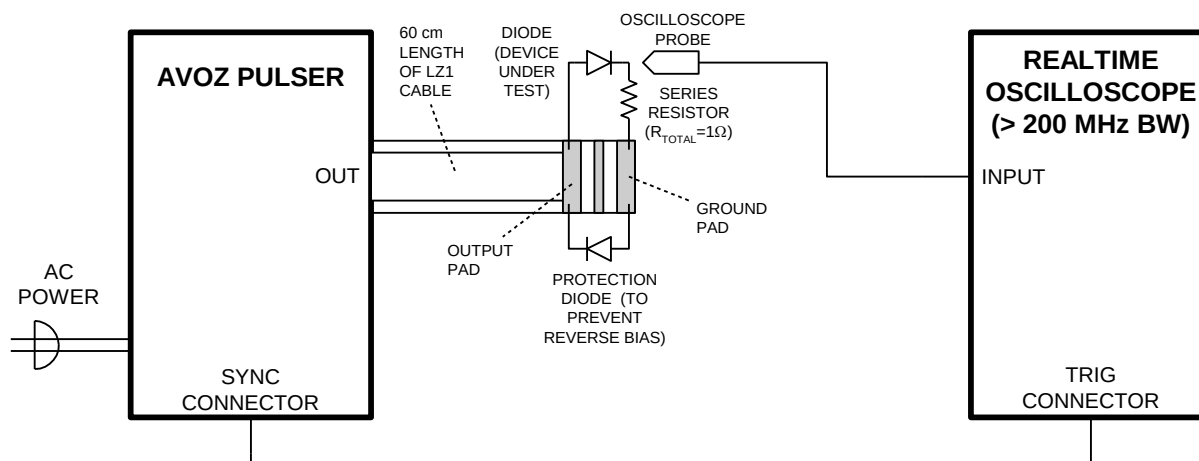

NOTE: BOTH DIODES ARE SHOWN ORIENTED FOR A POSITIVE OUTPUT. REVERSE BOTH DIODES FOR NEGATIVE OPERATION.

There are several key points to note. As explained above, a resistance should be added in series with the diode load, to limit the maximum current. This resistance may also be used to monitor the current through the diode current. If connected as shown above, the resistor voltage displayed on the oscilloscope is directly proportional to the diode current. It is essential the low-inductance resistors be used. Several non-inductive, medium power resistors should be used in parallel (for instance, five 4.7 Ohm 2W resistors). The Ohmite OY series (www.ohmite.com) or the RCD RSF2B series (www.rcd-comp.com) are appropriate.

It is also recommended that a low-capacitance, high-voltage, ultra-fast Schottky rectifier diode be connected for reverse-bias protection, especially for sensitive or costly devices under test. The APT (www.advancedpower.com) APT15S20K is an example of a suitable diode. Note, however, that the capacitance added by the protection diode may degrade the output rise time slightly.

USING THE LZ OUTPUT LINE

A flexible, low-characteristic-impedance transmission line is supplied with this instrument. One end plugs into the front-panel OUT connector, and the other end is terminated with a 1.0×2.5 cm section of glass epoxy circuit board. The end that plugs into the front panel is marked with an “UP” side and a “DOWN” side. (The UP side is the signal output, and the DOWN side is ground.) It is critically important that the “UP” side of the line be visible.

The load may be soldered to the circuit board end. The circuit board layout is illustrated below:

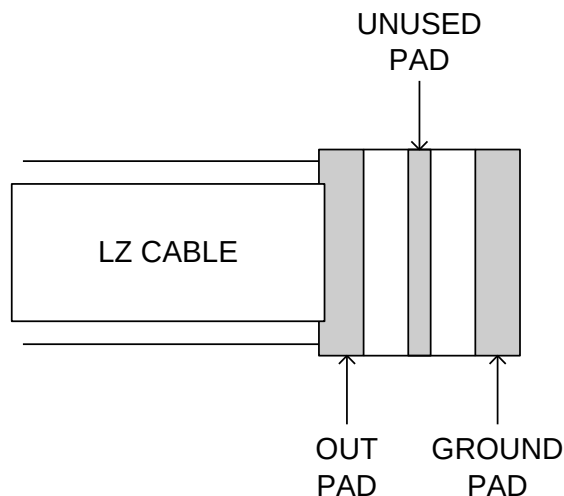

The length of leads used to connect the load to the circuit board should be kept extremely short (< 0.5 cm), as discussed below.

LENZ'S LAW AND INDUCTIVE VOLTAGE SPIKES

This instrument is designed to pulse resistive and diode loads and will exhibit a large output spike when used to drive a load with significant inductance (as predicted by LENZ'S LAW). For this reason the load should be connected to the output using low inductance leads (as short as possible and as heavy a gauge as possible).

The voltage developed across an inductance L (in Henries), when the current is changing at a rate given by di_{LOAD}/dt (in Amps/sec), is: $V_{SPIKE} = L \times di_{LOAD}/dt$.

For this reason, the length of leads used to connect the load to the circuit board should be kept extremely short (< 0.5 cm).

ATTACHING AND DETACHING LOADS

To avoid damaging the loads connected to main outputs, the loads should only be connected to or removed from the instrument when the instrument is off. Do not connect loads when the instrument is on and the output amplitude is not zero. This can cause sparking.

START-UP CHECK-LIST FOR LOCAL CONTROL

- 1) Install a 1 Ω , 10 Watt test load between the signal out and ground pads on the LZ1 circuit board. (Factory tests are conducted using five 4.7 Ω , 2 Watt resistors connected in parallel.)
- 2) Connect a cable from the SYNC OUT connector to the TRIG input of an oscilloscope. Set the oscilloscope to trigger externally.
- 3) Connect an oscilloscope probe to the signal side of the test load. On the oscilloscope, set the channel A vertical scale to 20 V/div, and the horizontal scale to 100 ns/div.
- 4) Turn on the instrument. The main menu will appear on the LCD.
- 5) To set the instrument to trigger from the internal clock at a PRF of 1 kHz:
 - The arrow pointer should be pointing at the frequency menu item. If it is not, press the MOVE button until it is.
 - Press the CHANGE button. The frequency submenu will appear. Rotate the ADJUST knob until the frequency is set at 1 kHz.
 - The arrow pointer should be pointing at the “Internal” choice. If it is not, press MOVE until it is.
 - Press CHANGE to return to the main menu.
- 6) To set the delay to 100 ns:
 - Press the MOVE button until the arrow pointer is pointing at the delay menu item.
 - Press the CHANGE button. The delay submenu will appear. Rotate the ADJUST knob until the delay is set at 100 ns.
 - Press CHANGE to return to the main menu.
- 7) To set the OUT pulse width to 500 ns:
 - Press the MOVE button until the arrow pointer is pointing at the “PW” menu item.
 - Press the CHANGE button. The pulse width submenu will appear. Rotate the ADJUST knob until the pulse width is set at 500 ns.

- The arrow pointer should be pointing at the “Normal” choice. If it is not, press MOVE until it is.
- Press CHANGE to return to the main menu.

8) At this point, nothing should appear on the oscilloscope.

9) To enable the output:

- Press the MOVE button until the arrow pointer is pointing at the output menu item.
- Press the CHANGE button. The output submenu will appear.
- Press MOVE until the arrow pointer is pointing at the “ON” choice.
- Press CHANGE to return to the main menu.

10) To change the OUT output amplitude:

- Press the MOVE button until the arrow pointer is pointing at the AMP menu item.
- Press the CHANGE button. The amplitude submenu will appear. Rotate the ADJUST knob until the amplitude is set at 100 V (or -100V for “-N” units).
- Observe the oscilloscope. You should see 500 ns wide, 100V pulses on the probe connected to the main output.
- Press CHANGE to return to the main menu.

11) Try varying the pulse width, by repeating step (7). As you rotate the ADJUST knob, the pulse width on the oscilloscope will change. It should agree with the displayed value.

12) This completes the operational check.

If additional assistance is required:

Tel: (613) 226-5772,
Fax: (613) 226-2802
Email: info@avtechpulse.com

MECHANICAL INFORMATION

TOP COVER REMOVAL

If necessary, the interior of the instrument may be accessed by removing the four Phillips screws on the top panel. With the four screws removed, the top cover may be slid back (and off).

Always disconnect the power cord before opening the instrument.

There are no user-adjustable internal circuits. For repairs other than fuse replacement, please contact Avtech (info@avtechpulse.com) to arrange for the instrument to be returned to the factory for repair.

⚠ Caution: High voltages are present inside the instrument during normal operation. Do not operate the instrument with the cover removed.

RACK MOUNTING

A rack mounting kit is available. The -R5 rack mount kit may be installed after first removing the one Phillips screw on the side panel adjacent to the front handle.

ELECTROMAGNETIC INTERFERENCE

To prevent electromagnetic interference with other equipment, all used outputs should be connected to shielded 50Ω loads using shielded 50Ω coaxial cables. Unused outputs should be terminated with shielded 50Ω coaxial terminators or with shielded coaxial dust caps, to prevent unintentional electromagnetic radiation. All cords and cables should be less than 3m in length.

MAINTENANCE

REGULAR MAINTENANCE

This instrument does not require any regular maintenance.

On occasion, one or more of the four rear-panel fuses may require replacement. All fuses can be accessed from the rear panel. See the “FUSES” section for details.

CLEANING

If desired, the interior of the instrument may be cleaned using compressed air to dislodge any accumulated dust. (See the “TOP COVER REMOVAL” section for instructions on accessing the interior.) No other cleaning is recommended.

CALIBRATION ADJUSTMENTS - SOFTWARE PROCEDURES

ADJUSTING AMPLITUDE ACCURACY

If it is found that the output amplitude settings (as set by the front-panel controls or programming commands) do not agree exactly with measured values of amplitude (i.e., by examining the output on an oscilloscope), the amplitude calibration can be updated using software commands.

The following procedure is suggested:

- 1) Connect a 1 Ω high-power resistive load to the output.
- 2) Connect the pulse generator to a computer using the GPIB or RS232 ports.
- 3) Turn on the pulse generator, and set the time controls (frequency, delay, pulse width) to typical values.
- 4) Turn on the outputs.
- 5) Set the output amplitude to 100V.
- 6) Observe the voltage across the load. (For example, suppose it is 104V).
- 7) Send the measured value to the instrument using the following command:

```
diag:ampl:cal 104
```

The internal software compares the supplied measured value to the programmed value, and adjusts the internal calibration data to null out any differences.

- 8) Observe the voltage across the load again. The amplitude setting should now agree with the measured value.

Information on more extensive timing and amplitude calibration procedures is available at <http://www.avtechpulse.com/appnote/>.

PROGRAMMING YOUR PULSE GENERATOR

KEY PROGRAMMING COMMANDS

The “OP1B Interface Programming Manual” describes in detail how to connect the pulse generator to your computer, and the programming commands themselves. A large number of commands are available; however, normally you will only need a few of these. Here is a basic sample sequence of commands that might be sent to the instrument after power-up:

*rst	(resets the instrument)
trigger:source internal	(selects internal triggering)
frequency 10 Hz	(sets the frequency to 10 Hz)
pulse:width 100 ns	(sets the pulse width to 100 ns)
pulse:delay 1 us	(sets the delay to 1 us)
output on	(turns on the output)
source:volt 50V	(sets the voltage amplitude to 50 Volts)

For triggering a single event, this sequence would be more appropriate:

*rst	(resets the instrument)
trigger:source hold	(turns off all triggering)
pulse:width 100 ns	(sets the pulse width to 100 ns)
output on	(turns on the output)
source:volt 50V	(sets the voltage amplitude to 50 Volts)
trigger:source immediate	(generates a single non-repetitive trigger event)
trigger:source hold	(turns off all triggering)
output off	(turns off the output)

To set the instrument to trigger from an external TTL signal applied to the rear-panel TRIG connector, use:

*rst	(resets the instrument)
trigger:source external	(selects external triggering)
pulse:width 100 ns	(sets the pulse width to 100 ns)
pulse:delay 1 us	(sets the delay to 1 us)
source:volt 50V	(sets the voltage amplitude to 50 Volts)
output on	(turns on the output)

These commands will satisfy 90% of your programming needs.

ALL PROGRAMMING COMMANDS

For more advanced programmers, a complete list of the available commands is given below. These commands are described in detail in the “OP1B Interface Programming Manual”. (Note: this manual also includes some commands that are not implemented in this instrument. They can be ignored.)

<u>Keyword</u>	<u>Parameter</u>	<u>Notes</u>
DIAGnostic: :AMPLitude :CALibration:	<numeric value>	[no query form]
LOCAL MEASure: :AMPLitude?		[query only]
OUTPut: :[STATe] :PROTection :TRIPped?	<boolean value>	[query only]
REMOTE [SOURce]: :FREQuency [:CW FIXed]	<numeric value>	
[SOURce]: :VOLTagE [:LEVel] [:IMMediate] [:AMPLitude]	<numeric value>	
:PROTection :TRIPped?		[query only]
[SOURce]: :PULSe :PERiod :WIDTh :DCYClE :HOLD :DELay :GATE :TYPE :LEVel	<numeric value> <numeric value> <numeric value> WIDTh DCYClE <numeric value> ASYNC SYNC HIgh Low	
STATUS: :OPERation :[EVENT]? :CONDition? :ENABle	<numeric value>	[query only, always returns "0"] [query only, always returns "0"] [implemented but not useful]
:QUEStionable :[EVENT]? :CONDition? :ENABle	<numeric value>	[query only, always returns "0"] [query only, always returns "0"] [implemented but not useful]
SYSTEM: :COMMunicate :GPIB :ADDReSS :SERial :CONTRol	<numeric value>	

:RTS	ON IBFull RFR	
:[RECeive]		
:BAUD	1200 2400 4800 9600	
:BITS	7 8	
:ECHO	<boolean value>	
:PARity		
:[TYPE]	EVEN ODD NONE	
:SBITS	1 2	
:ERRor		
:[NEXT]?		[query only]
:COUNT?		[query only]
:VERSion?		[query only]
TRIGger:		
:SOURce	INTernal EXTernal MANual HOLD IMMEDIATE	
*CLS		[no query form]
*ESE	<numeric value>	
*ESR?		[query only]
*IDN?		[query only]
*OPC		
*SAV	0 1 2 3	[no query form]
*RCL	0 1 2 3	[no query form]
*RST		[no query form]
*SRE	<numeric value>	
*STB?		[query only]
*TST?		[query only]
*WAI		[no query form]

PERFORMANCE CHECK SHEET