



AVTECH ELECTROSYSTEMS LTD.

NANOSECOND WAVEFORM ELECTRONICS  
SINCE 1975

P.O. BOX 265  
OGDENSBURG, NY  
U.S.A. 13669-0265

TEL: 888-670-8729 (USA & Canada) or +1-613-686-6675 (Intl)  
FAX: 800-561-1970 (USA & Canada) or +1-613-686-6679 (Intl)

info@avtechpulse.com - <http://www.avtechpulse.com/>

BOX 5120, LCD MERIVALE  
OTTAWA, ONTARIO  
CANADA K2C 3H5

INSTRUCTIONS

MODEL AVOZ-DF3-B

200 VOLT, 20 AMP

PULSE GENERATOR

WITH IEEE 488.2 AND RS-232 CONTROL

SERIAL NUMBER: \_\_\_\_\_

### WARRANTY

Avtech Electrosystems Ltd. warrants products of its manufacture to be free from defects in material and workmanship under conditions of normal use. If, within one year after delivery to the original owner, and after prepaid return by the original owner, this Avtech product is found to be defective, Avtech shall at its option repair or replace said defective item. This warranty does not apply to units which have been disassembled, modified or subjected to conditions exceeding the applicable specifications or ratings. This warranty is the extent of the obligation assumed by Avtech with respect to this product and no other warranty or guarantee is either expressed or implied.

### TECHNICAL SUPPORT

Phone: 888-670-8729 (USA & Canada) or +1-613-686-6675 (International)

Fax: 800-561-1970 (USA & Canada) or +1-613-686-6679 (International)

E-mail: [info@avtechpulse.com](mailto:info@avtechpulse.com)

World Wide Web: <http://www.avtechpulse.com>

## TABLE OF CONTENTS

<b>WARRANTY.....</b>	<b>2</b>
<b>TECHNICAL SUPPORT.....</b>	<b>2</b>
<b>TABLE OF CONTENTS.....</b>	<b>3</b>
<b>INTRODUCTION.....</b>	<b>5</b>
<b>SPECIFICATIONS.....</b>	<b>6</b>
<b>REGULATORY NOTES.....</b>	<b>7</b>
FCC PART 18.....	7
EC DECLARATION OF CONFORMITY.....	7
DIRECTIVE 2002/95/EC (RoHS).....	8
DIRECTIVE 2002/96/EC (WEEE).....	8
AC POWER SUPPLY REGULATORY NOTES.....	9
FIRMWARE LICENSING.....	9
<b>INSTALLATION.....</b>	<b>10</b>
VISUAL CHECK.....	10
POWER RATINGS.....	10
CONNECTION TO THE POWER SUPPLY.....	10
PROTECTION FROM ELECTRIC SHOCK.....	11
ENVIRONMENTAL CONDITIONS.....	12
LABVIEW DRIVERS.....	12
<b>FUSES.....</b>	<b>13</b>
AC FUSE REPLACEMENT.....	13
DC FUSE REPLACEMENT.....	14
FUSE RATINGS.....	14
<b>FRONT PANEL CONTROLS.....</b>	<b>15</b>
<b>REAR PANEL CONTROLS.....</b>	<b>17</b>
<b>GENERAL INFORMATION.....</b>	<b>19</b>
BASIC PULSE CONTROL.....	19
TRIGGER MODES.....	21
GATING MODES.....	21
THE LOAD AND OUTPUT MODULE.....	21
MEASUREMENT BANDWIDTH ISSUES.....	23
PREVENTING OUTPUT STAGE FAILURE.....	23
<b>OPERATIONAL CHECK.....</b>	<b>24</b>

<b>PROGRAMMING YOUR PULSE GENERATOR.....</b>	<b>27</b>
KEY PROGRAMMING COMMANDS.....	27
ALL PROGRAMMING COMMANDS.....	28
<b>MECHANICAL INFORMATION.....</b>	<b>30</b>
TOP COVER REMOVAL.....	30
RACK MOUNTING.....	30
ELECTROMAGNETIC INTERFERENCE.....	30
<b>MAINTENANCE.....</b>	<b>31</b>
REGULAR MAINTENANCE.....	31
CLEANING.....	31
<b>WIRING DIAGRAMS.....</b>	<b>32</b>
WIRING OF AC POWER.....	32
PCB 158Q - LOW VOLTAGE POWER SUPPLY, 1/3.....	33
PCB 158Q - LOW VOLTAGE POWER SUPPLY, 2/3.....	34
PCB 158Q - LOW VOLTAGE POWER SUPPLY, 3/3.....	35
PCB 170C - HIGH VOLTAGE DC POWER SUPPLY.....	36
PCB 235B - HIGH VOLTAGE DC POWER SUPPLY.....	37
PCB 104F - KEYPAD / DISPLAY BOARD, 1/3.....	38
PCB 104F - KEYPAD / DISPLAY BOARD, 2/3.....	39
PCB 104F - KEYPAD / DISPLAY BOARD, 3/3.....	40
MAIN WIRING - POSITIVE (-P) UNITS.....	41
<b>PERFORMANCE CHECK SHEET.....</b>	<b>42</b>

## INTRODUCTION

The AVOZ-DF3-B is a high performance, GPIB and RS232-equipped pulser generator that features five identical outputs. These outputs can either be combined to drive a single low-impedance (10 Ohm) load, or can be used separately to drive five 50 Ohm loads simultaneously. This unique flexibility makes the AVOZ-DF3-B ideal for testing high-current laser diode arrays, as well as testing multiple identical lower-current devices (for instance, production testing of attenuators).

The AVOZ-DF3-B is capable of generating up to 200V on each of its five identical outputs, at repetition rates up to 25 kHz. The pulse width is variable from 20 to 200 ns. Rise and fall times are fixed at less than 5 ns. The AVOZ-DF3-B includes an internal trigger source, but it can also be triggered or gated by an external source. A front-panel pushbutton can also be used to trigger the instrument.

The five outputs are all wired to the same point internally, and thus share common timing and amplitude controls. If the five outputs are connected to a common 10 Ohm load, the AVOZ-DF3-B can deliver up to 20 Amps of pulsed current to the load.

Five output cables and an output module are included to simplify the connection of a single load to the multiple outputs.

The output voltage polarity depends on the model number:

"-P" units: up to +200 Volts

"-N" units: up to -200 Volts

The AVOZ-DF3-B features front panel keyboard and adjust knob control of the output pulse parameters along with a four line by 40-character backlit LCD display of the output amplitude, pulse width, pulse repetition frequency, and delay. The instrument includes memory to store up to four complete instrument setups. The operator may use the front panel or the computer interface to store a complete "snapshot" of all key instrument settings, and recall this setup at a later time.

The instrument is protected against overload conditions (such as short circuits) by an automatic control circuit. An internal power supply monitor removes the power to the output stage for five seconds if an average power overload exists. After that time, the unit operates normally for one second, and if the overload condition persists, the power is cut again. This cycle repeats until the overload is removed.

This instrument is intended for use in research, development, test and calibration laboratories by qualified personnel.

## SPECIFICATIONS

Model <sup>1</sup> :	AVOZ-DF3-B
Amplitude: voltage: current:	20 to 200V 0 to 20A
Required load impedance <sup>2</sup> (R <sub>LOAD</sub> ):	10 Ω
Pulse width (FWHM):	20 to 200 ns
Rise and fall times (20%-80%):	< 5 ns
Maximum PRF:	25 kHz
Maximum average output power:	20 Watts
Polarity <sup>2</sup> :	Positive or negative (specify)
Propagation delay:	< 200 ns (Ext trig in to pulse out)
Jitter:	± 100 ps ± 0.03% of sync delay (Ext trig in to pulse out)
Trigger modes:	Internal trigger, external trigger (TTL level pulse, > 10 ns, 1 kΩ input impedance), front-panel "Single Pulse" pushbutton, or single pulse trigger via computer command.
Sync delay:	Variable, 0 to ±1.0 seconds (sync out to pulse out)
Sync output:	+ 3 Volts, 100 ns, will drive 50 Ohm loads
Gate input:	Synchronous or asynchronous, active high or low, switchable. Suppresses triggering when active.
Mainframe output connector (on the rear panel):	Five SMA connectors (wired in parallel internally)
Supplied 1m/36" SMA-to-SMA coaxial cables):	5
Included output module:	An output module containing the required series resistance, and capable of dissipating the maximum average power, is provided. The input side mates to the provided coaxial cables, which connect to the mainframe output connectors. The output is provided on a 2 cm x 2 cm (3/4" x 3/4") section of microstrip circuit board. The load/DUT should be soldered between the output and ground pads on this circuit board. Avtech can provide special socketing arrangements for packaged diodes upon request. Note that any added inductance present in the output-pad-to-diode path (L <sub>1</sub> ) and diode-to-ground-pad path (L <sub>2</sub> ) will degrade the output rise and fall times according to the inductive time constant, $\tau = (L_1 + L_2) / R_{LOAD}$
Other connectors:	Trig, Gate, Sync: BNC
GPIO & RS-232 control <sup>1</sup> :	Standard on -B units. See <a href="http://www.avtechpulse.com/gpio">http://www.avtechpulse.com/gpio</a> for details.
LabView drivers:	Check <a href="http://www.avtechpulse.com/labview">http://www.avtechpulse.com/labview</a> for availability and downloads
Ethernet port, for remote control using VXI-11.3, ssh, telnet, & web:	Optional <sup>4</sup> . Recommended as a modern alternative to GPIO / RS-232. See <a href="http://www.avtechpulse.com/options/vxi">http://www.avtechpulse.com/options/vxi</a> for details.
Settings resolution:	The resolution of the timing parameters varies, but is always ≤ 0.15% of the set value. The amplitude resolution is typically 0.02% of the maximum amplitude.
Settings accuracy:	Typically ± 3% (±2 ns or ± 2% of max. amplitude) after 10 minute warmup. For high-accuracy applications requiring traceable calibration, verify the output with a calibrated oscilloscope.
Power, temperature:	100 - 240 Volts, 50 - 60 Hz.
Dimensions:	Mainframe: 100 x 430 x 375 mm (3.9 x 17 x 14.8"), Output module: 25 x 42 x 64 mm (1 x 1.65 x 2.5")
Chassis material:	Anodized aluminum, with blue plastic trim
Temperature range:	+5°C to +40°C

1) -B suffix indicates IEEE-488.2 GPIO and RS-232 control of pulse amplitude, pulse width, delay and PRF. (See <http://www.avtechpulse.com/gpio>).

2) A series resistance of this value is included in the provided output module, to permit operation with low-impedance diode loads.

3) Indicate desired polarity by suffixing the model number with -P or -N (i.e. positive or negative).

4) Add the suffix -VXI to the model number to specify the Ethernet port.

## REGULATORY NOTES

### FCC PART 18

This device complies with part 18 of the FCC rules for non-consumer industrial, scientific and medical (ISM) equipment.

This instrument is enclosed in a rugged metal chassis and uses a filtered power entry module (where applicable). The main output signal is provided on a shielded connector that is intended to be used with shielded coaxial cabling and a shielded load. Under these conditions, the interference potential of this instrument is low.

If interference is observed, check that appropriate well-shielded cabling is used on the output connectors. Contact Avtech ([info@avtechpulse.com](mailto:info@avtechpulse.com)) for advice if you are unsure of the most appropriate cabling. Also, check that your load is adequately shielded. It may be necessary to enclose the load in a metal enclosure.

If any of the connectors on the instrument are unused, they should be covered with shielded metal "dust caps" to reduce the interference potential.

This instrument does not normally require regular maintenance to minimize interference potential. However, if loose hardware or connectors are noted, they should be tightened. Contact Avtech ([info@avtechpulse.com](mailto:info@avtechpulse.com)) if you require assistance.

### EC DECLARATION OF CONFORMITY



We                      Avtech Electrosystems Ltd.  
                             P.O. Box 5120, LCD Merivale  
                             Ottawa, Ontario  
                             Canada K2C 3H5

declare that this pulse generator meets the intent of Directive 2004/108/EG for Electromagnetic Compatibility. Compliance pertains to the following specifications as listed in the official Journal of the European Communities:

EN 50081-1 Emission

EN 50082-1 Immunity

and that this pulse generator meets the intent of the Low Voltage Directive 72/23/EEC as amended by 93/68/EEC. Compliance pertains to the following specifications as listed in the official Journal of the European Communities:

EN 61010-1:2001 Safety requirements for electrical equipment for measurement, control, and laboratory use

#### DIRECTIVE 2002/95/EC (RoHS)

This instrument is exempt from Directive 2002/95/EC of the European Parliament and of the Council of 27 January 2003 on the Restriction of the use of certain Hazardous Substances (RoHS) in electrical and electronic equipment. Specifically, Avtech instruments are considered "Monitoring and control instruments" (Category 9) as defined in Annex 1A of Directive 2002/96/EC. The Directive 2002/95/EC only applies to Directive 2002/96/EC categories 1-7 and 10, as stated in the "Article 2 - Scope" section of Directive 2002/95/EC.

#### DIRECTIVE 2002/96/EC (WEEE)

European customers who have purchased this equipment directly from Avtech will have completed a "WEEE Responsibility Agreement" form, accepting responsibility for WEEE compliance (as mandated in Directive 2002/96/EC of the European Union and local laws) on behalf of the customer, as provided for under Article 9 of Directive 2002/96/EC.

Customers who have purchased Avtech equipment through local representatives should consult with the representative to determine who has responsibility for WEEE compliance. Normally, such responsibilities will lie with the representative, unless other arrangements (under Article 9) have been made.

Requirements for WEEE compliance may include registration of products with local governments, reporting of recycling activities to local governments, and financing of recycling activities.





## AC POWER SUPPLY REGULATORY NOTES

This instrument converts the AC input power to the +24V DC voltage that powers the internal circuitry of this instrument using a Tamura AAD130SD-60-A switching power supply. According to the manufacturer, the Tamura AAD130SD-60-A has the following certifications:

UL60950-1  
IEC60950 -1  
CSA C22.2 No. 60950- 1  
EN60950 -1

and is compliant with:

EN61000-3-2  
EN61000-4-2 Level 2  
EN61000-4-2 Level 3 (Air Only)  
EN61000-4-4 Level 3  
EN61000-4-5 Level 3  
EN61000-4-11  
CISPR 11 and 22 FCC Part 15 Class B (conducted)

## FIRMWARE LICENSING

Instruments with firmware versions 5.00 or higher use open-source software internally. Some of this software requires that the source code be made available to the user as a condition of its licensing. This source code is available upon request (contact [info@avtechpulse.com](mailto:info@avtechpulse.com)).

Earlier firmware versions do not contain any open source software.

## INSTALLATION

### VISUAL CHECK

After unpacking the instrument, examine to ensure that it has not been damaged in shipment. Visually inspect all connectors, knobs, liquid crystal displays (LCDs), and the handles. Confirm that a power cord, a GPIB cable, and two instrumentation manuals (this manual and the “Programming Manual for -B Instruments”) are with the instrument. If the instrument has been damaged, file a claim immediately with the company that transported the instrument.

### POWER RATINGS

This instrument is intended to operate from 100 - 240 V, 50 - 60 Hz.

The maximum power consumption is 90 Watts. Please see the “FUSES” section for information about the appropriate AC and DC fuses.

This instrument is an “Installation Category II” instrument, intended for operation from a normal single-phase supply.

### CONNECTION TO THE POWER SUPPLY

An IEC-320 three-pronged recessed male socket is provided on the back panel for AC power connection to the instrument. One end of the detachable power cord that is supplied with the instrument plugs into this socket. The other end of the detachable power cord plugs into the local mains supply. Use only the cable supplied with the instrument. The mains supply must be earthed, and the cord used to connect the instrument to the mains supply must provide an earth connection. (The supplied cord does this.)

 Warning: Failure to use a grounded outlet may result in injury or death due to electric shock. This product uses a power cord with a ground connection. It must be connected to a properly grounded outlet. The instrument chassis is connected to the ground wire in the power cord.

The table below describes the power cord that is normally supplied with this instrument, depending on the destination region:

Destination Region	Description	Option	Manufacturer	Part Number
United Kingdom, Hong Kong, Singapore, Malaysia	BS 1363, 230V, 50 Hz	-AC00	Qualtek	370001-E01
Australia, New Zealand	AS 3112:2000, 230-240V, 50 Hz	-AC01	Qualtek	374003-A01
Continental Europe, Korea, Indonesia, Russia	European CEE 7/7 "Schuko" 230V, 50 Hz	-AC02	Qualtek	364002-D01
North America, Taiwan	NEMA 5-15, 120V, 60 Hz	-AC03	Qualtek	312007-01
Switzerland	SEV 1011, 230V, 50 Hz	-AC06	Qualtek	378001-E01
South Africa, India	SABS 164-1, 220-250V, 50 Hz	-AC17	Volex	2131H 10 C3
Japan	JIS 8303, 100V, 50-60 Hz	-AC18	Qualtek	397002-01
Israel	SI 32, 220V, 50 Hz	-AC19	Qualtek	398001-01
China	GB 1002-1, 220V, 50 Hz	-AC22	Volex	2137H 10 C3

## PROTECTION FROM ELECTRIC SHOCK

 Operators of this instrument must be protected from electric shock at all times. The owner must ensure that operators are prevented access and/or are insulated from every connection point. In some cases, connections must be exposed to potential human contact. Operators must be trained to protect themselves from the risk of electric shock. This instrument is intended for use by qualified personnel who recognize shock hazards and are familiar with safety precautions required to avoid possibly injury. In particular, operators should:

1. Keep exposed high-voltage wiring to an absolute minimum.
2. Wherever possible, use shielded connectors and cabling.
3. Connect and disconnect loads and cables only when the instrument is turned off.
4. Keep in mind that all cables, connectors, oscilloscope probes, and loads must have an appropriate voltage rating.
5. Do not attempt any repairs on the instrument, beyond the fuse replacement procedures described in this manual. Contact Avtech technical support (see page 2 for contact information) if the instrument requires servicing. Service is to be performed solely by qualified service personnel.

## ENVIRONMENTAL CONDITIONS

This instrument is intended for use under the following conditions:

1. indoor use;
2. altitude up to 2 000 m;
3. temperature 5 °C to 40 °C;
4. maximum relative humidity 80 % for temperatures up to 31 °C decreasing linearly to 50 % relative humidity at 40 °C;
5. Mains supply voltage fluctuations up to  $\pm 10$  % of the nominal voltage;
6. no pollution or only dry, non-conductive pollution.

## LABVIEW DRIVERS

A LabVIEW driver for this instrument is available for download on the Avtech web site, at <http://www.avtechpulse.com/labview>. A copy is also available in National Instruments' Instrument Driver Library at <http://www.natinst.com/>.

## FUSES

This instrument contains four fuses. All are accessible from the rear-panel. Two protect the AC prime power input, and two protect the internal DC power supplies. The locations of the fuses on the rear panel are shown in the figure below:



### AC FUSE REPLACEMENT

To physically access the AC fuses, the power cord must be detached from the rear panel of the instrument. The fuse drawer may then be extracted using a small flat-head screwdriver, as shown below:



## DC FUSE REPLACEMENT

The DC fuses may be replaced by inserting the tip of a flat-head screwdriver into the fuse holder slot, and rotating the slot counter-clockwise. The fuse and its carrier will then pop out.

## FUSE RATINGS

The following table lists the required fuses:

Fuses	Nominal Mains Voltage	Rating	Case Size	Recommended Replacement Part	
				Littelfuse Part Number	Digi-Key Stock Number
#1, #2 (AC)	115 V	0.8A, 250V, Time-Delay	5×20 mm	0218.800HXP	F2418-ND
	230 V	0.5A, 250V, Time-Delay	5×20 mm	0218.500HXP	F2416-ND
#3 (DC)	N/A	3.15A, 250V, Time-Delay	5×20 mm	02183.15HXP	F2430-ND
#4 (DC)	N/A	2.0A, 250V, Time-Delay	5×20 mm	0218002.HXP	F2420-ND

The recommended fuse manufacturer is Littelfuse (<http://www.littelfuse.com>).

Replacement fuses may be easily obtained from Digi-Key (<http://www.digikey.com>) and other distributors.

## FRONT PANEL CONTROLS

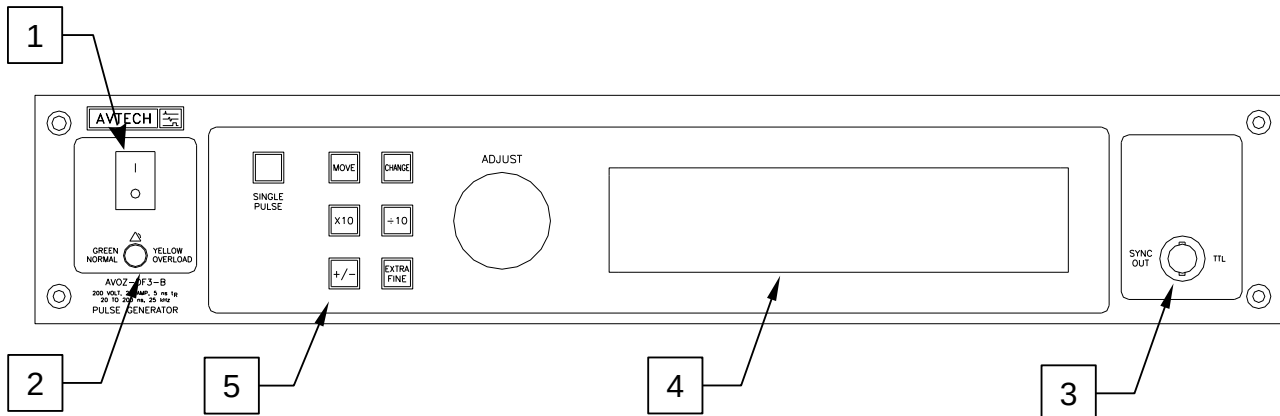

1. **POWER Switch.** This is the main power switch. When turning the instrument on, there is normally a delay of 5-10 seconds before anything is shown on the main display.

If the main menu does not appear after 30 seconds, turn off the instrument and leave it off for at least 60 seconds before applying power again.

Allow 60 seconds before re-powering an instrument that has been switched off. If the power is switched more frequently than that, the turn-on delay may be longer (up to 20 seconds) as the internal software performs filesystem checks, or the instrument may remain unresponsive indefinitely.

2. **OVERLOAD Indicator.** When the instrument is powered, this indicator is normally green, indicating normal operation. If this indicator is yellow, an internal automatic overload protection circuit has been tripped. If the unit is overloaded (by operating at an exceedingly high duty cycle or by operating into a very low impedance), the protective circuit will disable the output of the instrument and turn the indicator light yellow. The light will stay yellow (i.e. output disabled) for about 5 seconds after which the instrument will attempt to re-enable the output (i.e. light green) for about 1 second. If the overload condition persists, the output will be disabled again (i.e. light yellow) for another 5 seconds. If the overload condition has been removed, the instrument will resume normal operation.

This overload indicator may flash yellow briefly at start-up. This is not a cause for concern.

3. **SYNC OUT.** This connector supplies a SYNC output that can be used to trigger other equipment, particularly oscilloscopes. This signal leads (or lags) the main output by a duration set by the "DELAY" controls and has an approximate amplitude of +3 Volts to  $R_L > 1k\Omega$  with a pulse width of approximately 100 ns.

4. LIQUID CRYSTAL DISPLAY (LCD). This LCD is used in conjunction with the keypad to change the instrument settings. Normally, the main menu is displayed, which lists the key adjustable parameters and their current values. The "Programming Manual for -B Instruments" describes the menus and submenus in detail.
5. KEYPAD.

Control Name	Function
MOVE	This moves the arrow pointer on the display.
CHANGE	This is used to enter the submenu, or to select the operating mode, pointed to by the arrow pointer.
×10	If one of the adjustable numeric parameters is displayed, this increases the setting by a factor of ten.
÷10	If one of the adjustable numeric parameters is displayed, this decreases the setting by a factor of ten.
+/-	If one of the adjustable numeric parameters is displayed, and this parameter can be both positive or negative, this changes the sign of the parameter.
EXTRA FINE	This changes the step size of the ADJUST knob. In the extra-fine mode, the step size is twenty times finer than in the normal mode. This button switches between the two step sizes.
ADJUST	This large knob adjusts the value of any displayed numeric adjustable values, such as frequency, pulse width, etc. The adjust step size is set by the "EXTRA FINE" button.  When the main menu is displayed, this knob can be used to move the arrow pointer.



## REAR PANEL CONTROLS

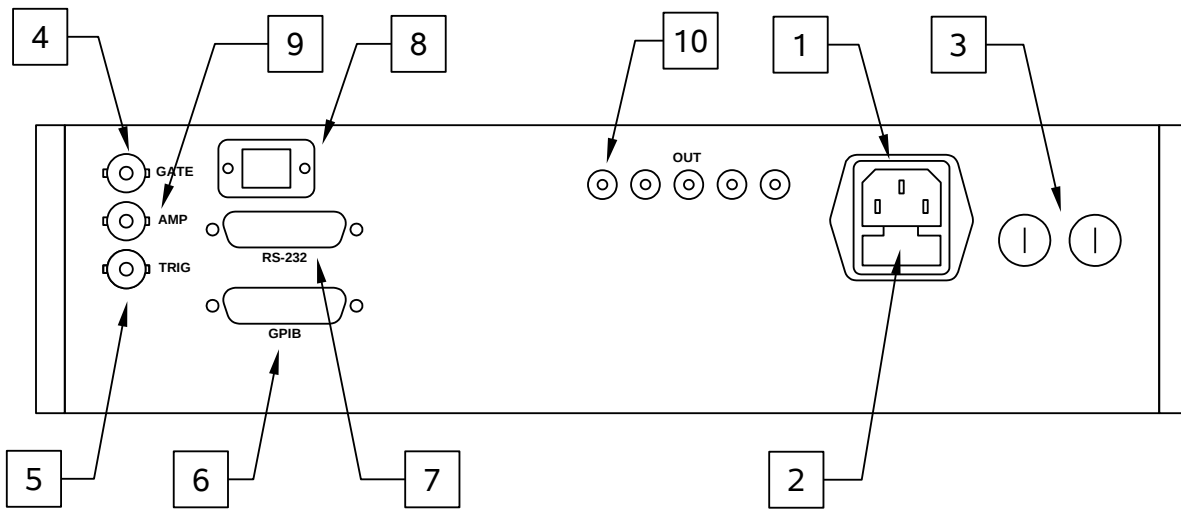

*Note: some connectors may be in different positions than shown above, depending on the exact combination of options ordered.*

1. AC POWER INPUT. An IEC-320 C14 three-pronged recessed male socket is provided on the back panel for AC power connection to the instrument. One end of the detachable power cord that is supplied with the instrument plugs into this socket.
2. AC FUSE DRAWER. The two fuses that protect the AC input are located in this drawer. Please see the “FUSES” section of this manual for more information.
3. DC FUSES. These two fuses protect the internal DC power supplies. Please see the “FUSES” sections of this manual for more information.
4. GATE. This TTL-level (0 and +5V) logic input can be used to gate the triggering of the instrument. This input can be either active high or active low, depending on the front panel settings or programming commands. (The instrument triggers normally when this input is unconnected). When set to active high mode, this input is pulled-down to ground by a 1 k $\Omega$  resistor. When set to active low mode, this input is pulled-up to +5V by a 1 k $\Omega$  resistor.
5. TRIG. This TTL-level (0 and +5V) logic input can be used to trigger the instrument, if the instrument is set to triggering externally. The instrument triggers on the rising edge of this input. The input impedance of this input is 1 k $\Omega$ . (Depending on the length of cable attached to this input, and the source driving it, it may be desirable to add a coaxial 50 Ohm terminator to this input to provide a proper transmission line termination. The Pasternack ([www.pasternack.com](http://www.pasternack.com)) PE6008-50 BNC feed-thru 50 Ohm terminator is suggested for this purpose.)

6. GPIB Connector. A standard GPIB cable can be attached to this connector to allow the instrument to be computer-controlled. See the “Programming Manual for -B Instruments” for more details on GPIB control.
7. RS-232 Connector. A standard serial cable with a 25-pin male connector can be attached to this connector to allow the instrument to be computer-controlled. A user name (“admin”) and a password (“default”, as shipped from the factory) are required when logging into a serial terminal session. The internal controller attempts to auto-sense the parity setting. It may be necessary to send a few return characters before attempting a login in order to provide enough data to allow this auto-sensing to work. (A standard Linux “agetty” process is used to implement serial control internally.) See the “Programming Manual for -B Instruments” for more details on RS-232 control.
8. Network Connector. (Optional feature. Present on -VXI units only.) This Ethernet connector allows the instrument to be remotely controlled using the VXI-11.3, ssh (secure shell), telnet, and http (web) protocols. See the “Programming Manual for -B Instruments” for more details.
9. AMP Connector. (Optional feature. Present on "-EA" units only.) The output amplitude can be set to track the voltage on this input. Zero Volts in corresponds to zero amplitude output, and +10V in corresponds to maximum amplitude within the selected range. This mode is activated by selecting "Ext Control" on the front-panel amplitude menu, or with the "source:voltage external" command.
10. OUT CONNECTORS. These five SMA connectors provide the main output signals. Each output should be terminated with a 50 $\Omega$  load (or, equivalently, all five outputs may be connected to a common 10 $\Omega$  load). These five connectors are all wired to the same point internally. No output should be left unterminated, or reflections may occur on the connected outputs.

## GENERAL INFORMATION

### BASIC PULSE CONTROL

This instrument can be triggered by its own internal clock or by an external TTL trigger signal. In either case, two output channels respond to the trigger: OUT and SYNC. The OUT channel is the signal that is applied to the load. Its amplitude and pulse width are variable. The SYNC pulse is a fixed-width TTL-level reference pulse used to trigger oscilloscopes or other measurement systems. When the delay is set to a positive value the SYNC pulse precedes the OUT pulse. When the delay is set to a negative value the SYNC pulse follows the OUT pulse.

These pulses are illustrated below, assuming internal triggering and a positive delay:

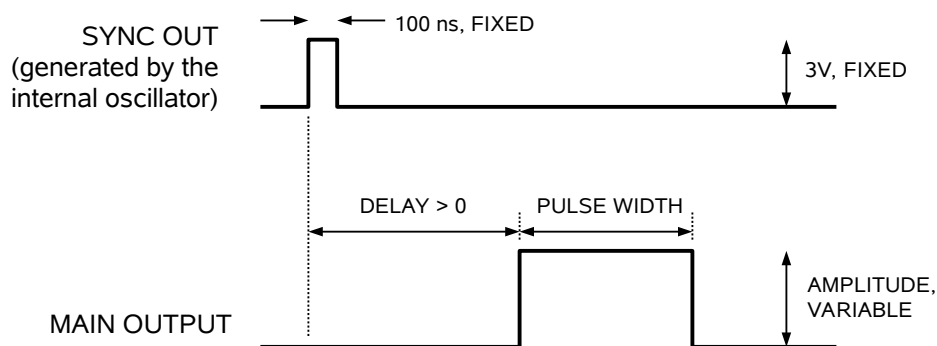

*Figure A*

If the delay is negative, the order of the SYNC and OUT pulses is reversed:

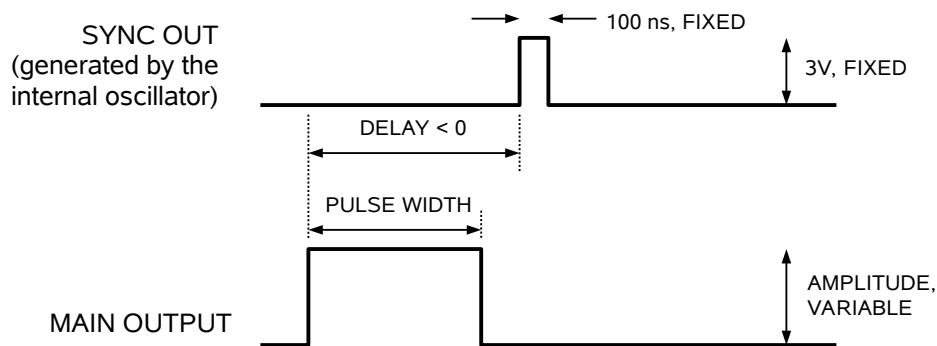

*Figure B*

The next figure illustrates the relationship between the signal when an external TTL-level trigger is used:

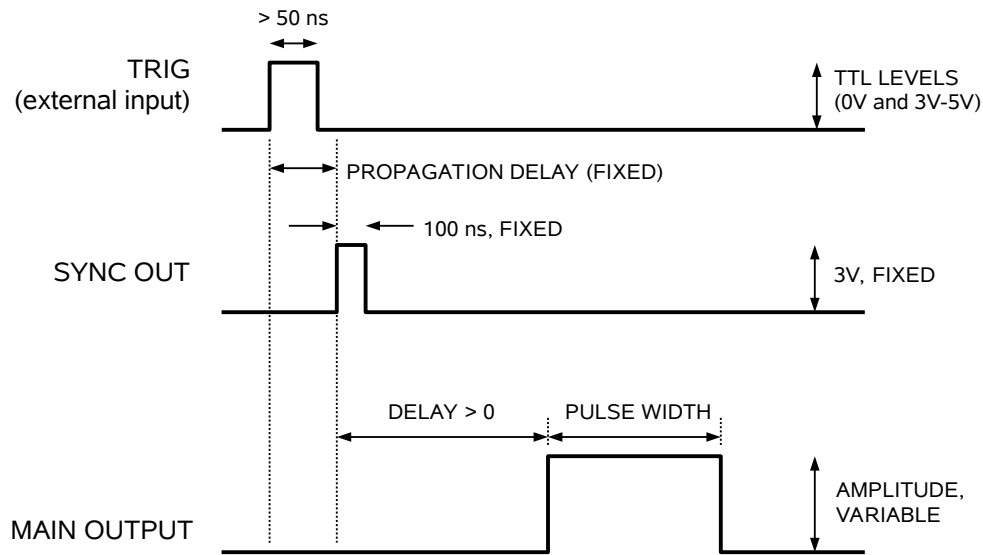

Figure C

As before, if the delay is negative, the order of the SYNC and OUT pulses is reversed.

The last figure illustrates the relationship between the signal when an external TTL-level trigger is used in the  $\text{PW}_{\text{IN}} = \text{PW}_{\text{OUT}}$  mode. In this case, the output pulse width equals the external trigger's pulse width (approximately), and the delay circuit is bypassed:

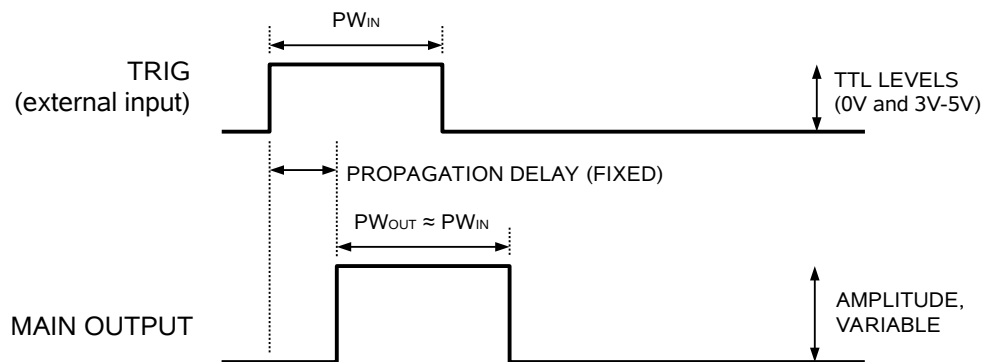

Figure D

The delay, pulse width, and frequency (when in the internal mode), of the OUT pulse can be varied with front panel controls or via the GPIB or RS-232 computer interfaces.

## TRIGGER MODES

This instrument has four trigger modes:

- Internal Trigger: the instrument controls the trigger frequency, and generates the clock internally.
- External Trigger: the instrument is triggered by an external TTL-level clock on the back-panel TRIG connector.
- Manual Trigger: the instrument is triggered by the front-panel “SINGLE PULSE” pushbutton.
- Hold Trigger: the instrument is set to not trigger at all.

These modes can be selected using the front panel trigger menu, or by using the appropriate programming commands. (See the “Programming Manual for -B Instruments” for more details.)

## GATING MODES

Triggering can be suppressed by a TTL-level signal on the rear-panel GATE connector. The instrument can be set to stop triggering when this input high or low, using the front-panel gate menu or the appropriate programming commands. This input can also be set to act synchronously or asynchronously. When set to asynchronous mode, the GATE will disable the output immediately. Output pulses may be truncated. When set to synchronous mode, the output will complete the full pulse width if the output is high, and then stop triggering. No pulses are truncated in this mode.

## THE LOAD AND OUTPUT MODULE

The AVOZ-DF3-B is a voltage pulser designed to drive 10Ω load impedances.

An AVX-RL2-10 output module is included which provides a high-current low-inductance 10Ω series resistance internally, to allow low-impedance loads (such as laser diodes) to be driven directly. The output module is connected to the mainframe using five supplied coaxial cables (giving a matched characteristic impedance  $Z_0$  of  $50\Omega / 5 = 10\Omega$ , in order to minimize transmission lines reflections).

With an output voltage of  $V_{OUT}$ , the current through the diode will be then given by Ohm's Law:

$$I_{DIODE} = (V_{OUT} - V_F) / 10\Omega$$

The basic test arrangement is shown below:

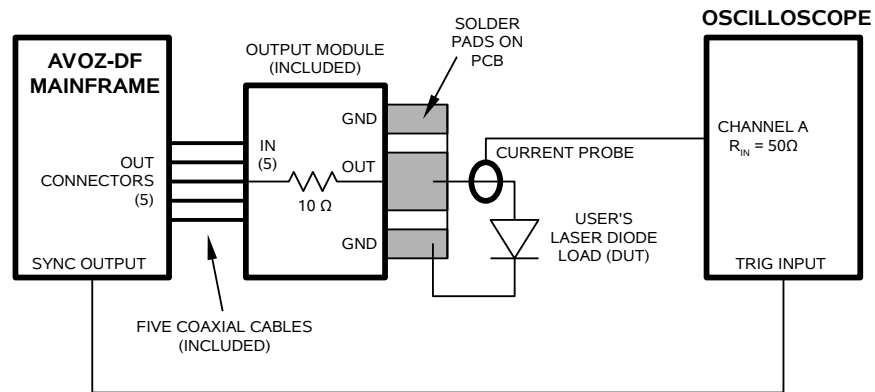

On the output module, the output signal is provided on the larger central pad on the protruding section of circuit board. The two edge pads are grounded. The back side of the board has a solid ground plane.

The output current should be measured with a current probe. Factory tests are conducted with the Integrated Sensor Technologies model 711S current probe. The Tektronix CT2 current probe is also suitable, although it is physically larger.

The user is not required to use the provided output module. The five outputs can be connected to a different 10 Ohm load impedance, as long as five cables are used (so that the total effective characteristic impedance of the cabling is  $Z_0 = 50\Omega \div 5 = 10\Omega$ ), and the 10 Ohm resistance is constructed with low parasitic inductance.

Alternatively, the AVOZ-DF3-B can be used to drive five entirely separate 50 Ohm loads, as shown below:

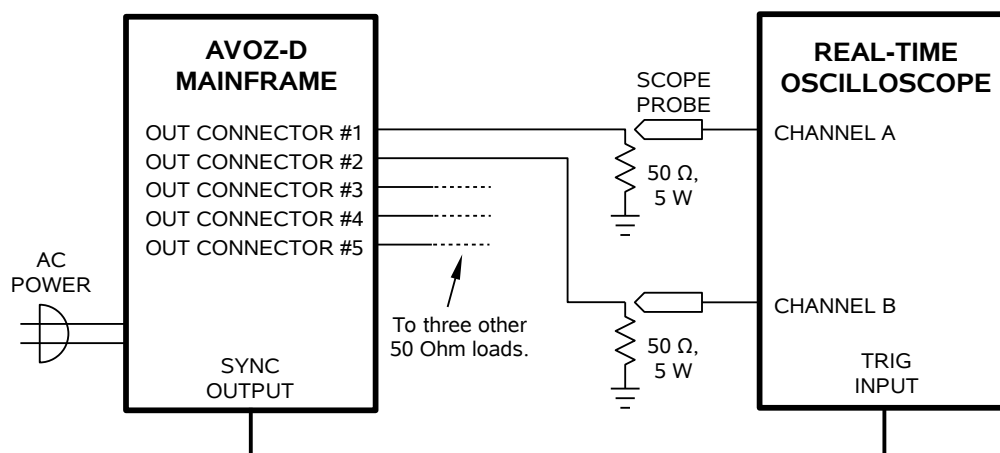

No output should be left unterminated, or reflections may occur on the connected outputs.

## MEASUREMENT BANDWIDTH ISSUES

The rise and fall times of the AVOZ-DF3-B are specified to be  $< 5$  ns, and in practice are closer to 2 ns. For best results, the bandwidth of the measurement system should exceed 1 GHz. Lower-bandwidth oscilloscopes and probes will introduce measurement artefacts – primarily “spikes” on the rising and falling edges. Please refer to the sample waveforms at the end of this manual for examples of waveforms recorded on high-bandwidth (20 GHz) oscilloscopes. You should be able to reproduce these waveforms, if your measurement system has an appropriate bandwidth.

## PREVENTING OUTPUT STAGE FAILURE

The output stage is protected against overload conditions by an overload circuit and fuses on the main frame back panel. However, the output switching elements may fail if the unit is triggered at a PRF exceeding 25 kHz or at duty cycles resulting in an average output power in excess of 20 Watts. Heating and subsequent possible failure of the output stage is reduced if the following action is taken where possible:

- PRF is kept to a minimum, i.e. operate in a low PRF range when possible rather than in a high PRF range.
- Keep the output PW to a minimum.
- Never apply an externally generated voltage to the output port.

## OPERATIONAL CHECK

This section describes a sequence to confirm the basic operation of the instrument. It should be performed after receiving the instrument. It is a useful learning exercise as well.

Before proceeding with this procedure, finish read this instruction manual thoroughly. Then read the “Local Control” section of the “Programming Manual for -B Instruments” thoroughly. The “Local Control” section describes the front panel controls used in this operational check - in particular, the MOVE, CHANGE, and ADJUST controls.

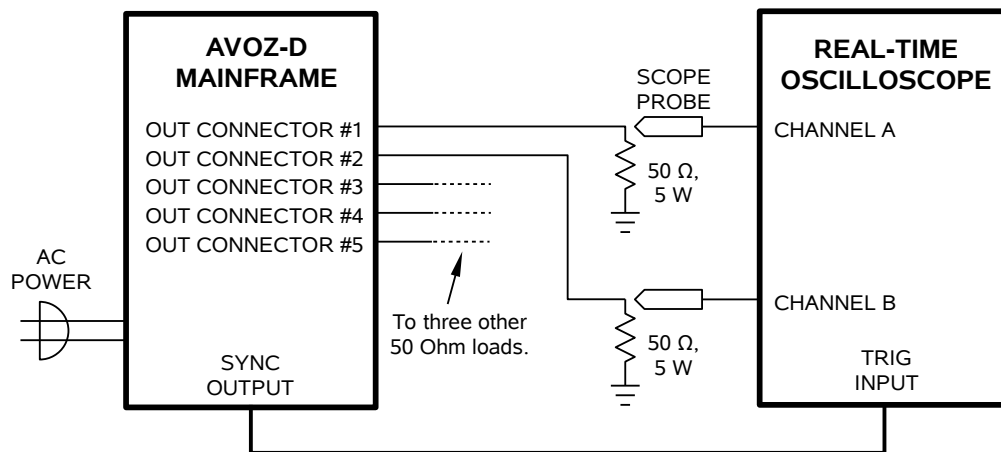

1. Connect a cable from the SYNC OUT connector to the TRIG input of an oscilloscope.
2. Connect a 50 Ohm load to each of the five outputs, using coaxial cabling. Connect one or more oscilloscope probes to the loads of your choice (all five loads should show the same waveform).
3. Set the oscilloscope to trigger externally with the vertical setting at 50 Volts/div and the horizontal setting at 100 ns/div.
4. Turn on the AVOZ-DF3-B. The main menu will appear on the LCD.
5. To set the AVOZ-DF3-B to trigger from the internal clock at a PRF of 100 Hz:
  - a) The arrow pointer should be pointing at the frequency menu item. If it is not, press the MOVE button until it is.
  - b) Press the CHANGE button. The frequency submenu will appear. Rotate the ADJUST knob until the frequency is set at 100 Hz.



- c) The arrow pointer should be pointing at the “Internal” choice. If it is not, press MOVE until it is.
  - d) Press CHANGE to return to the main menu.
6. To set the delay to 100 ns:
  - a) Press the MOVE button until the arrow pointer is pointing at the delay menu item.
  - b) Press the CHANGE button. The delay submenu will appear. Rotate the ADJUST knob until the delay is set at 100 ns.
  - c) The arrow pointer should be pointing at the “Normal” choice. If it is not, press MOVE until it is.
  - d) Press CHANGE to return to the main menu.
7. To set the pulse width to 200 ns:
  - a) Press the MOVE button until the arrow pointer is pointing at the pulse width menu item.
  - b) Press the CHANGE button. The pulse width submenu will appear. Rotate the ADJUST knob until the pulse width is set at 200 ns.
  - c) The arrow pointer should be pointing at the “Normal” choice. If it is not, press MOVE until it is.
  - d) Press CHANGE to return to the main menu.
8. At this point, nothing should appear on the oscilloscope.
9. To enable the output:
  - a) Press the MOVE button until the arrow pointer is pointing at the output menu item.
  - b) Press the CHANGE button. The output submenu will appear.
  - c) Press MOVE until the arrow pointer is pointing at the “ON” choice.
  - d) Press CHANGE to return to the main menu.
10. To change the output amplitude:

- a) Press the MOVE button until the arrow pointer is pointing at the amplitude menu item.
- b) Press the CHANGE button. The amplitude submenu will appear. Rotate the ADJUST knob until the amplitude is set at +200V (or -200V for "-N" instruments).
- c) Observe the oscilloscope. You should see 200 ns wide, 200V pulses.
- d) Rotate the ADJUST knob. The amplitude as seen on the oscilloscope should vary.
- e) Press CHANGE to return to the main menu.

11. Repeat step 10, but set the amplitude to zero.

12. This completes the operational check.

## PROGRAMMING YOUR PULSE GENERATOR

### KEY PROGRAMMING COMMANDS

The “Programming Manual for -B Instruments” describes in detail how to connect the pulse generator to your computer, and the programming commands themselves. A large number of commands are available; however, normally you will only need a few of these. Here is a basic sample sequence of commands that might be sent to the instrument after power-up:

*rst	(resets the instrument)
trigger:source internal	(selects internal triggering)
frequency 1000 Hz	(sets the frequency to 1000 Hz)
pulse:width 100 ns	(sets the pulse width to 100 ns)
pulse:delay 2 us	(sets the delay to 2 us)
volt 50	(sets the amplitude to 50 V)
output on	(turns on the output)

For triggering a single event, this sequence would be more appropriate:

*rst	(resets the instrument)
trigger:source hold	(turns off all triggering)
pulse:width 100 ns	(sets the pulse width to 100 ns)
pulse:delay 2 us	(sets the delay to 2 us)
output on	(turns on the output)
volt 50	(sets the amplitude to 50 V)
trigger:source immediate	(generates a single non-repetitive trigger event)
trigger:source hold	(turns off all triggering)
output off	(turns off the output)

To set the instrument to trigger from an external TTL signal applied to the rear-panel TRIG connector, use:

*rst	(resets the instrument)
trigger:source external	(selects external triggering)
pulse:width 100 ns	(sets the pulse width to 100 ns)
pulse:delay 2 us	(sets the delay to 2 us)
volt 50	(sets the amplitude to 50 V)
output on	(turns on the output)

These commands will satisfy 90% of your programming needs.

## ALL PROGRAMMING COMMANDS

For more advanced programmers, a complete list of the available commands is given below. These commands are described in detail in the “Programming Manual for -B Instruments”. (Note: this manual also includes some commands that are not implemented in this instrument. They can be ignored.)

<u>Keyword</u>	<u>Parameter</u>	<u>Notes</u>
OUTPut:		
:[STATe]	<boolean value>	
:PROTection		
:TRIPped?		[query only]
[SOURce]:		
:FREQuency		
[:CW   FIXed]	<numeric value>	
[SOURce]:		
:PULSe		
:PERiod	<numeric value>	
:WIDTh	<numeric value>   EXTeRnal	
:DCYClE	<numeric value>	
:HOLD	WIDTh   DCYClE	
:DELay	<numeric value>	
:GATE		
:TYPE	ASYNc   SYNc	
:LEVeL	HIgh   LOw	
[SOURce]:		
:VOLTagE		
[:LEVeL]		
[:IMMeDiate]		
[:AMPLitude]	<numeric value>   EXTeRnal	
:PROTection		
:TRIPped?		[query only]
STATUS:		
:OPERation		
:[EVENT]?		[query only, always returns "0"]
:CONDition?		[query only, always returns "0"]
:ENABle	<numeric value>	[implemented but not useful]
:QUEStionable		
:[EVENT]?		[query only, always returns "0"]
:CONDition?		[query only, always returns "0"]
:ENABle	<numeric value>	[implemented but not useful]
SYSTEM:		
:COMMunicate		
:GPIB		
:ADDReSS	<numeric value>	
:SERial		
:CONTRol		
:RTS	ON   IBFull   RFR	
:[RECeive]		
:BAUD	1200   2400   4800   9600   19200   38400   57600   115200	
:ERRor		
:[NEXT]?		[query only]
:COUNT?		[query only]
:VERSion?		[query only]

TRIGger:		
:SOURce	INTernal   EXTernal   MANual   HOLD   IMMEDIATE	
*CLS		[no query form]
*ESE	<numeric value>	
*ESR?		[query only]
*IDN?		[query only]
*OPC		
*SAV	0   1   2   3	[no query form]
*RCL	0   1   2   3	[no query form]
*RST		[no query form]
*SRE	<numeric value>	
*STB?		[query only]
*TST?		[query only]
*WAI		[no query form]

## MECHANICAL INFORMATION

### TOP COVER REMOVAL

If necessary, the interior of the instrument may be accessed by removing the four Phillips screws on the top panel. With the four screws removed, the top cover may be slid back (and off).

 Always disconnect the power cord and allow the instrument to sit unpowered for 10 minutes before opening the instrument. This will allow any internal stored charge to discharge.

There are no user-adjustable internal circuits. For repairs other than fuse replacement, please contact Avtech ([info@avtechpulse.com](mailto:info@avtechpulse.com)) to arrange for the instrument to be returned to the factory for repair. Service is to be performed solely by qualified service personnel.

 Caution: High voltages are present inside the instrument during normal operation. Do not operate the instrument with the cover removed.

### RACK MOUNTING

A rack mounting kit is available. The -R5 rack mount kit may be installed after first removing the one Phillips screw on the side panel adjacent to the front handle.

### ELECTROMAGNETIC INTERFERENCE

To prevent electromagnetic interference with other equipment, all used outputs should be connected to shielded loads using shielded coaxial cables. Unused outputs should be terminated with shielded coaxial terminators or with shielded coaxial dust caps, to prevent unintentional electromagnetic radiation. All cords and cables should be less than 3m in length.

## MAINTENANCE

### REGULAR MAINTENANCE

This instrument does not require any regular maintenance.

On occasion, one or more of the four rear-panel fuses may require replacement. All fuses can be accessed from the rear panel. See the “FUSES” section for details.

### CLEANING

If desired, the interior of the instrument may be cleaned using compressed air to dislodge any accumulated dust. (See the “TOP COVER REMOVAL” section for instructions on accessing the interior.) No other cleaning is recommended.





# PCB 158Q - LOW VOLTAGE POWER SUPPLY, 1/3

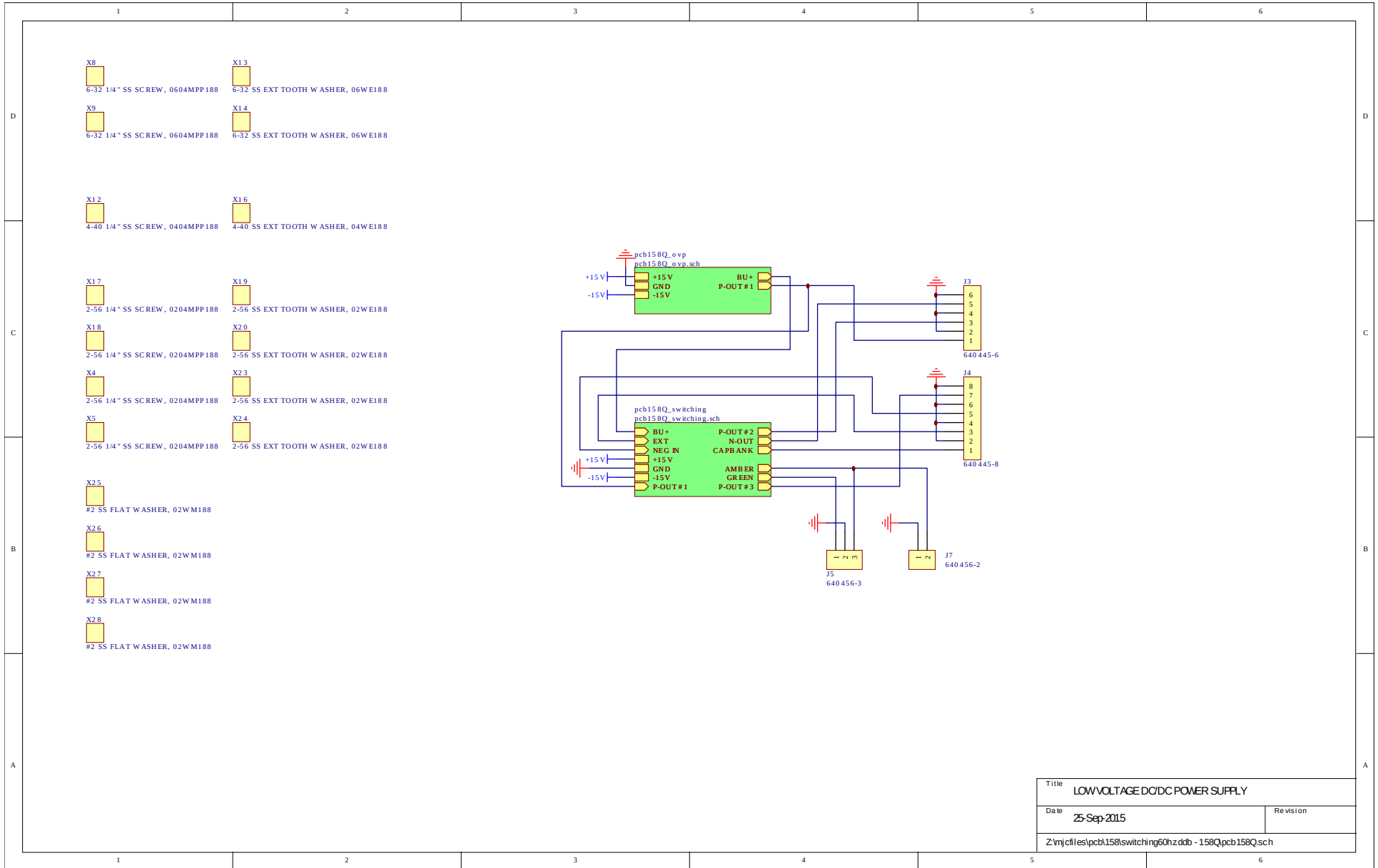

Title		LOW VOLTAGE DC/DC POWER SUPPLY
Date	25-Sep-2015	Revision
Z:\njcf\es\pcb158\switching60hzddb - 158Q.pcb158Q.sch		

# PCB 158Q - LOW VOLTAGE POWER SUPPLY, 2/3

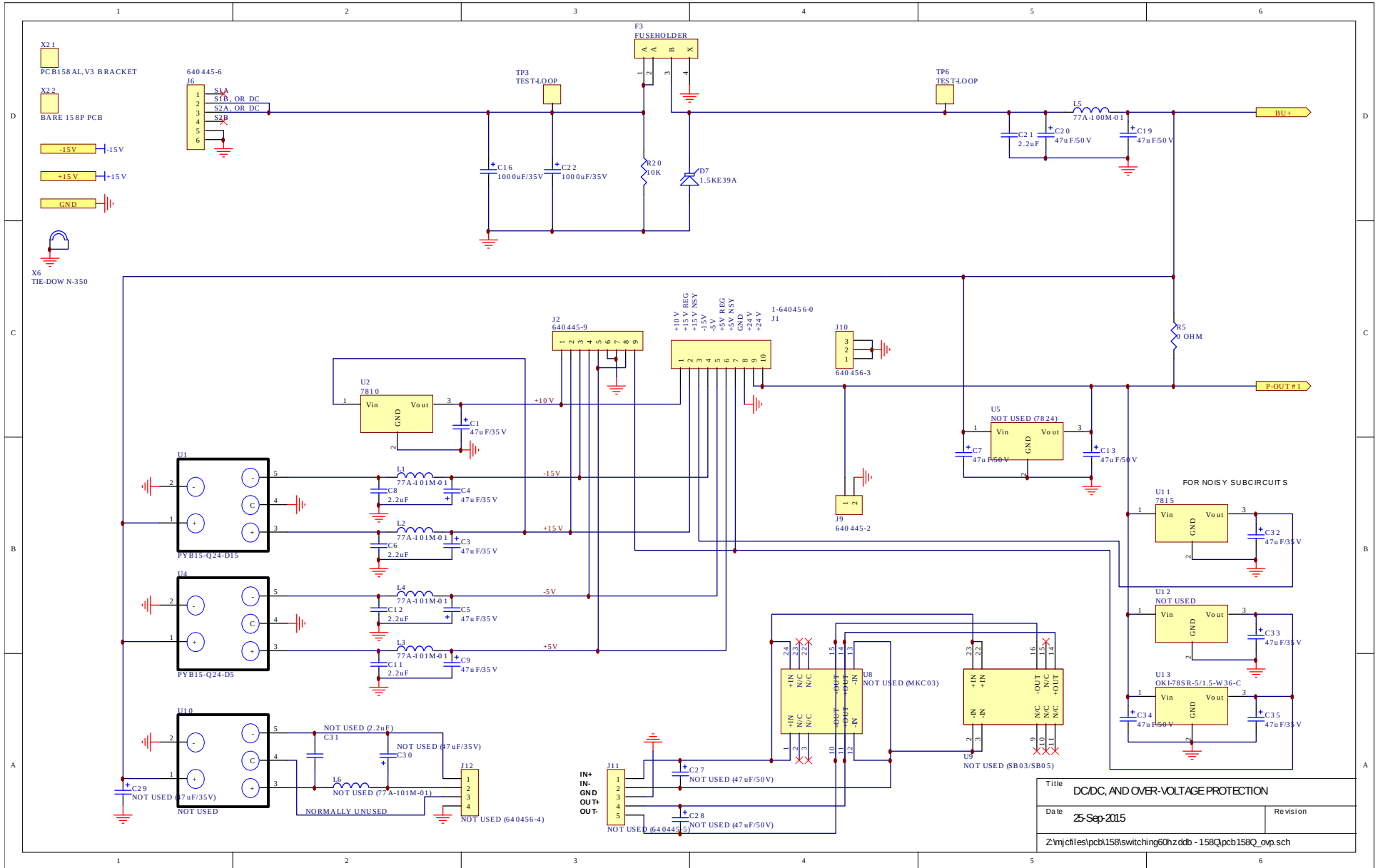

Title		
DC/DC, AND OVER-VOLTAGE PROTECTION		
Date	25-Sep-2015	Revision
Z:\njcf\es\pcb\158\switching60hzddb - 158Qpcb158Q_ovp.sch		

# PCB 158Q - LOW VOLTAGE POWER SUPPLY, 3/3

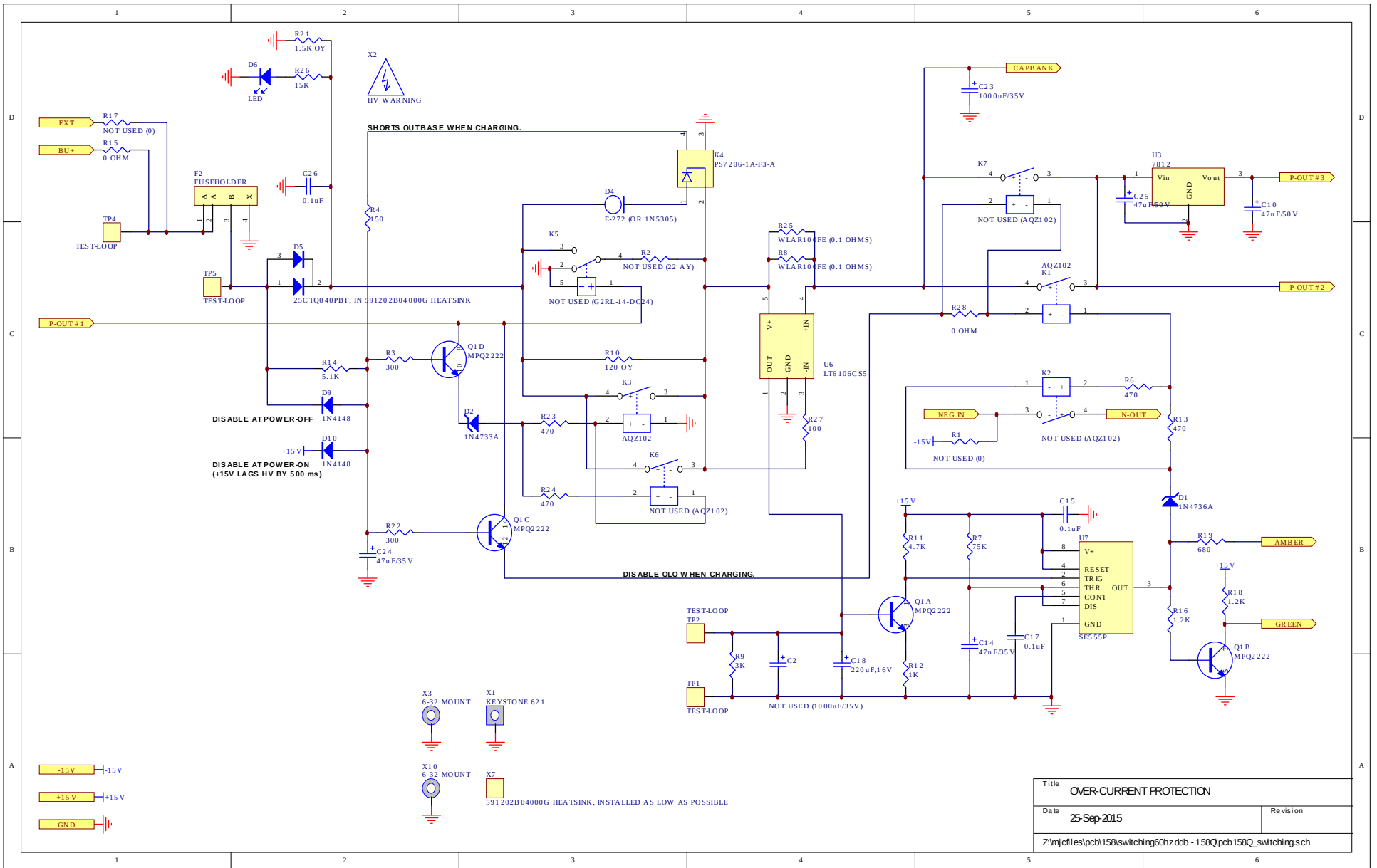

# PCB 170C - HIGH VOLTAGE DC POWER SUPPLY

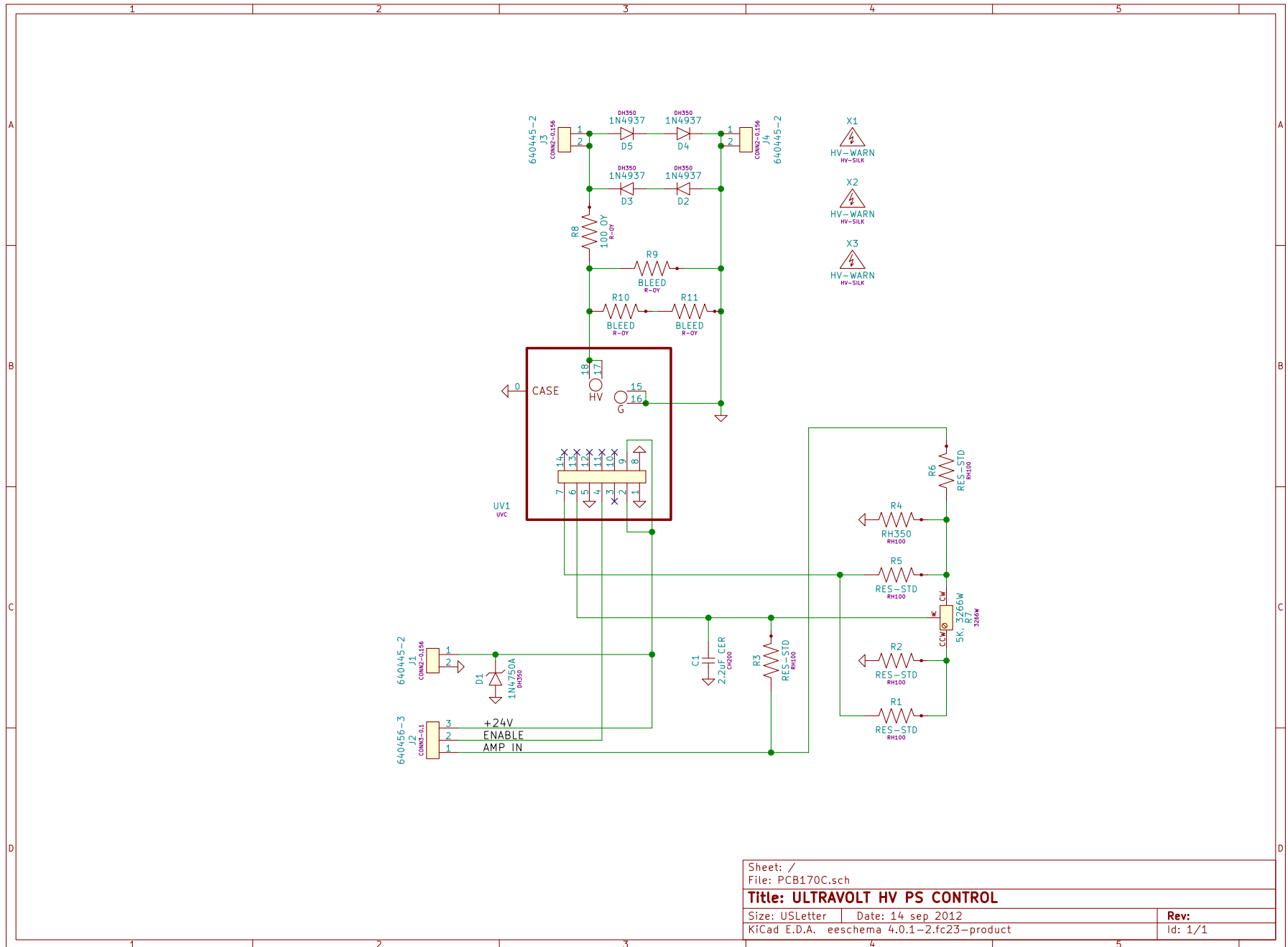

Sheet: /		File: PCB170C.sch	
<b>Title: ULTRAVOLT HV PS CONTROL</b>			
Size: USLetter	Date: 14 sep 2012	Rev:	
KiCad E.D.A. eeschema 4.0.1-2.fc23-product		Id: 1/1	

# PCB 235B - HIGH VOLTAGE DC POWER SUPPLY

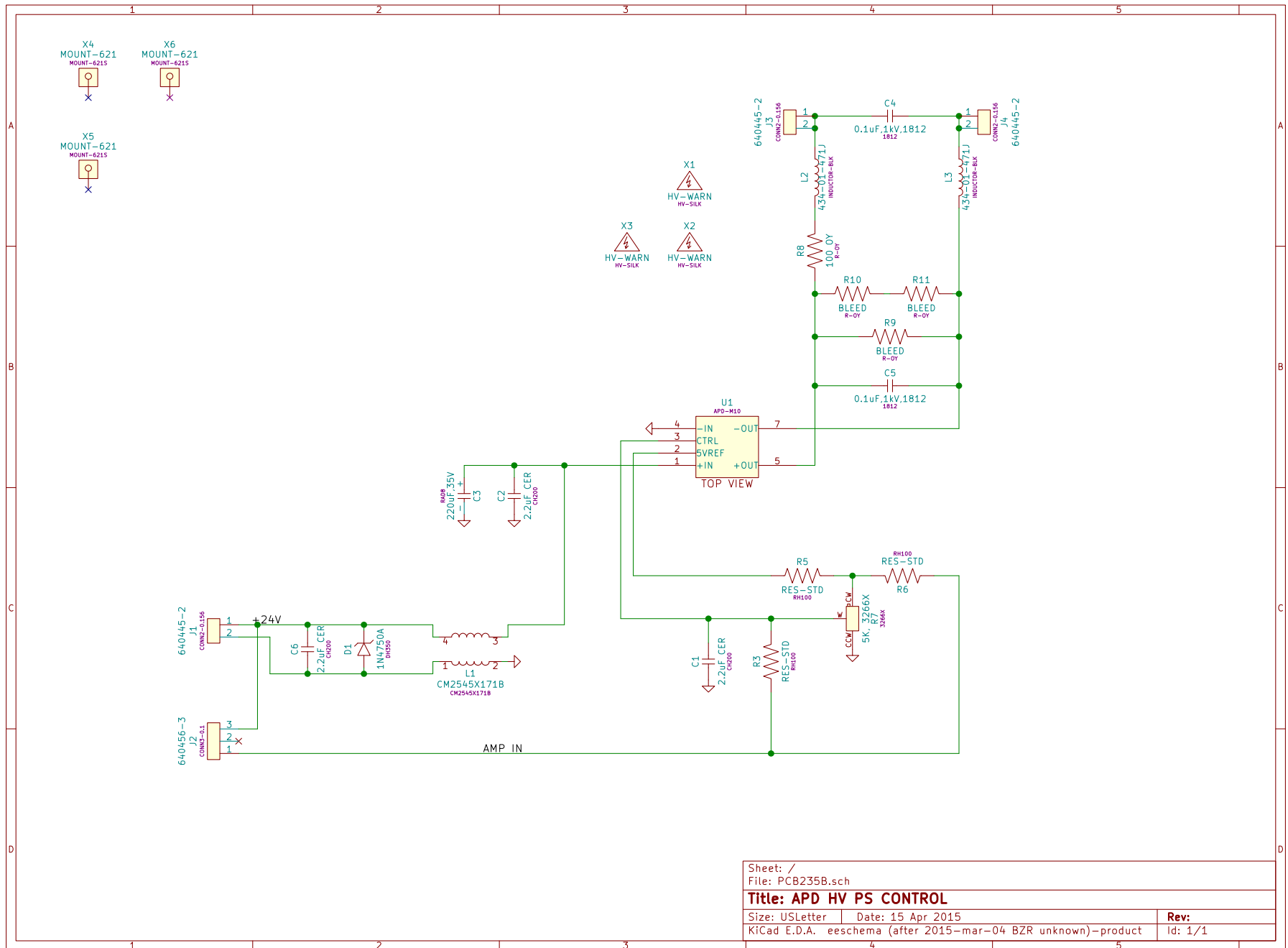

Sheet: /		File: PCB235B.sch	
<b>Title: APD HV PS CONTROL</b>			
Size: USLetter	Date: 15 Apr 2015	Rev:	
KICad E.D.A. eeschema (after 2015-mar-04 BZR unknown)-product			Id: 1/1

# PCB 104F - KEYPAD / DISPLAY BOARD, 1/3

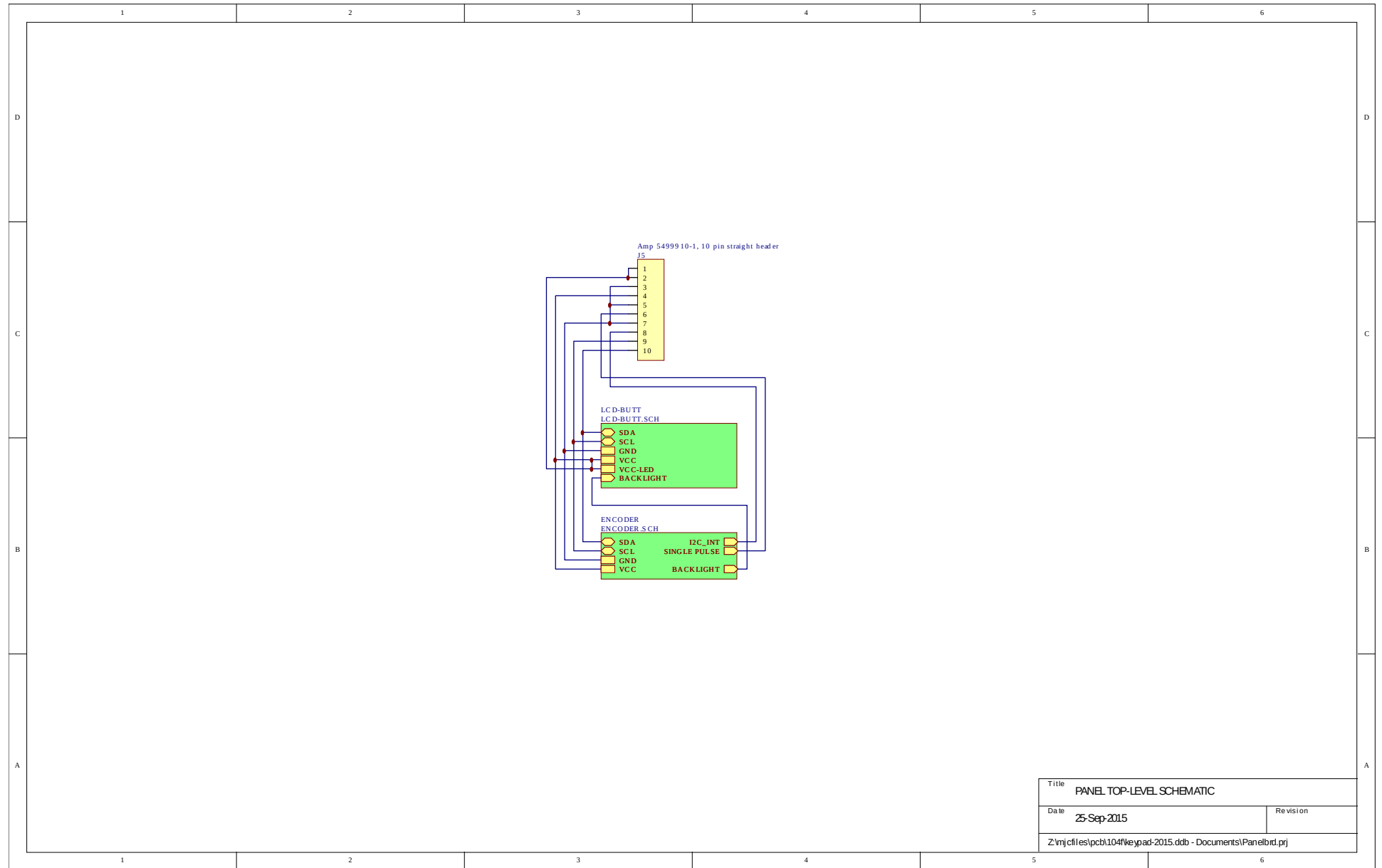

Title		PANEL TOP-LEVEL SCHEMATIC	
Date	25-Sep-2015	Revision	
Z:\njcf\es\pcb\104f\ keypad-2015.ddb - Documents\Panelrd.prj			

# PCB 104F - KEYPAD / DISPLAY BOARD, 2/3

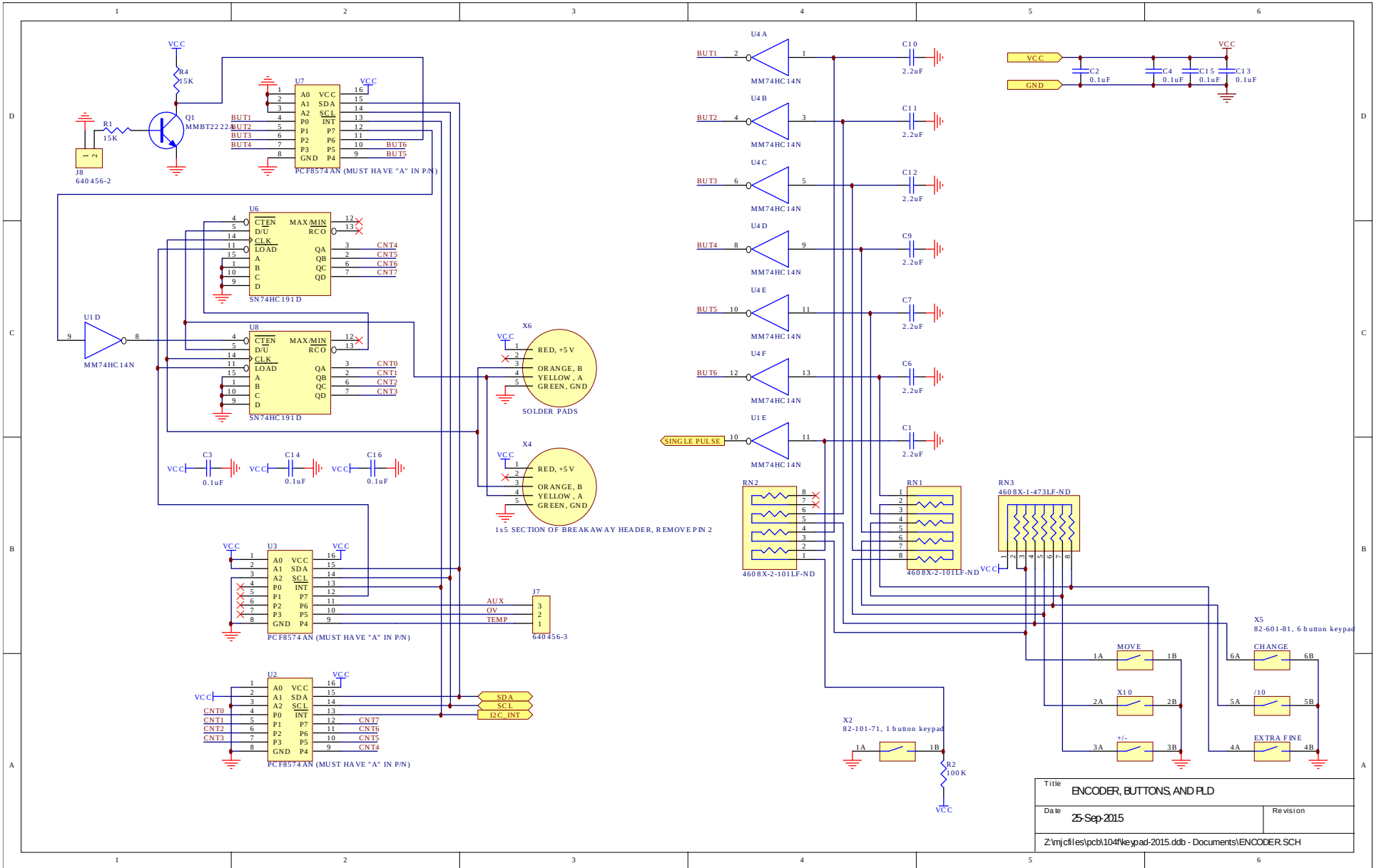

# PCB 104F - KEYPAD / DISPLAY BOARD, 3/3



Title		LCD CIRCUITS, MECHANICAL	
Date	25-Sep-2015	Revision	
Z:\njcf\es\pcb\104f\keypad-2015.ddb - Documents\LCD-BUT.T.SCH			



# MAIN WIRING - POSITIVE (-P) UNITS

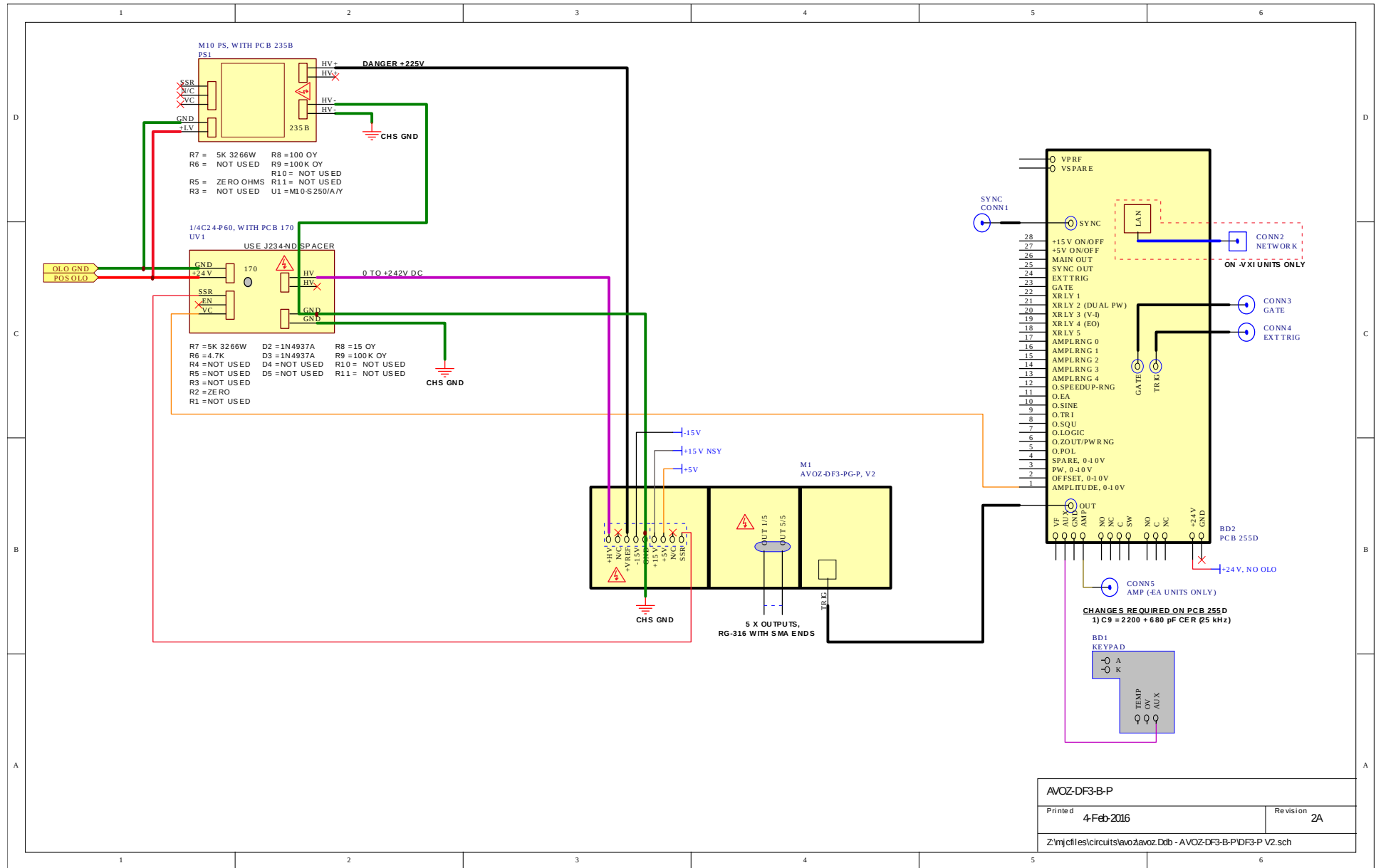

PERFORMANCE CHECK SHEET