



AVTECH ELECTROSYSTEMS LTD.

NANOSECOND WAVEFORM ELECTRONICS  
SINCE 1975

P.O. BOX 265  
OGDENSBURG, NY  
U.S.A. 13669-0265  
TEL: (315) 472-5270  
FAX: (613) 226-2802

TEL: 1-800-265-6681  
FAX: 1-800-561-1970

e-mail: [info@avtechpulse.com](mailto:info@avtechpulse.com)  
<http://www.avtechpulse.com/>

BOX 5120, LCD MERIVALE  
OTTAWA, ONTARIO  
CANADA K2C 3H4  
TEL: (613) 226-5772  
FAX: (613) 226-2802

## INSTRUCTIONS

MODEL AVOZ-F1-B

0 to -180 AMP, 20 ns PULSE WIDTH  
LASER DIODE DRIVER  
WITH IEEE 488.2 AND RS-232 CONTROL

SERIAL NUMBER: \_\_\_\_\_

### WARRANTY

Avtech Electrosystems Ltd. warrants products of its manufacture to be free from defects in material and workmanship under conditions of normal use. If, within one year after delivery to the original owner, and after prepaid return by the original owner, this Avtech product is found to be defective, Avtech shall at its option repair or replace said defective item. This warranty does not apply to units which have been disassembled, modified or subjected to conditions exceeding the applicable specifications or ratings. This warranty is the extent of the obligation assumed by Avtech with respect to this product and no other warranty or guarantee is either expressed or implied.

### TECHNICAL SUPPORT

Phone: 613-226-5772 or 1-800-265-6681

Fax: 613-226-2802 or 1-800-561-1970

E-mail: [info@avtechpulse.com](mailto:info@avtechpulse.com)

World Wide Web: <http://www.avtechpulse.com>

## TABLE OF CONTENTS

<b>WARRANTY.....</b>	<b>2</b>
<b>TECHNICAL SUPPORT.....</b>	<b>2</b>
<b>TABLE OF CONTENTS.....</b>	<b>3</b>
<b>INTRODUCTION.....</b>	<b>5</b>
<b>SPECIFICATIONS.....</b>	<b>6</b>
<b>EUROPEAN REGULATORY NOTES.....</b>	<b>7</b>
<b>EC DECLARATION OF CONFORMITY.....</b>	<b>7</b>
<b>DIRECTIVE 2002/95/EC (RoHS).....</b>	<b>7</b>
<b>INSTALLATION.....</b>	<b>8</b>
<b>VISUAL CHECK.....</b>	<b>8</b>
<b>POWER RATINGS.....</b>	<b>8</b>
<b>CONNECTION TO THE POWER SUPPLY.....</b>	<b>8</b>
<b>PROTECTION FROM ELECTRIC SHOCK.....</b>	<b>9</b>
<b>ENVIRONMENTAL CONDITIONS.....</b>	<b>9</b>
<b>FUSES.....</b>	<b>11</b>
<b>AC FUSE REPLACEMENT.....</b>	<b>11</b>
<b>DC FUSE REPLACEMENT.....</b>	<b>12</b>
<b>FUSE RATINGS.....</b>	<b>12</b>
<b>FRONT PANEL CONTROLS.....</b>	<b>13</b>
<b>REAR PANEL CONTROLS.....</b>	<b>15</b>
<b>GENERAL INFORMATION.....</b>	<b>17</b>
<b>BASIC PULSE CONTROL.....</b>	<b>17</b>
<b>TRIGGER MODES.....</b>	<b>18</b>
<b>GATING MODES.....</b>	<b>18</b>
<b>GENERAL INFORMATION - OPERATING INTO A LOAD.....</b>	<b>19</b>
<b>AMPLITUDE CONTROL.....</b>	<b>19</b>
<b>DESIGNING THE SERIES RESISTANCE.....</b>	<b>19</b>
<b>USING THE LZ1 OUTPUT LINE.....</b>	<b>19</b>
<b>HANDLING AND STORING THE LZ1 OUTLINE LINE.....</b>	<b>20</b>
<b>LENZ'S LAW AND INDUCTIVE VOLTAGE SPIKES.....</b>	<b>21</b>
<b>ATTACHING AND DETACHING LOADS.....</b>	<b>21</b>
<b>TEST ARRANGEMENT.....</b>	<b>22</b>
<b>TYPICAL WAVEFORMS.....</b>	<b>23</b>

AFTER-PULSE TRANSIENTS.....	24
DC OFFSET.....	24
HIGH-VOLTAGE PRECAUTIONS.....	24
<b>PROGRAMMING YOUR PULSE GENERATOR.....</b>	<b>25</b>
KEY PROGRAMMING COMMANDS.....	25
ALL PROGRAMMING COMMANDS.....	26
<b>MECHANICAL INFORMATION.....</b>	<b>28</b>
TOP COVER REMOVAL.....	28
RACK MOUNTING.....	28
ELECTROMAGNETIC INTERFERENCE.....	28
<b>MAINTENANCE.....</b>	<b>29</b>
REGULAR MAINTENANCE.....	29
CLEANING.....	29
<b>WIRING DIAGRAMS.....</b>	<b>0</b>
WIRING OF AC POWER.....	0
PCB 158H - LOW VOLTAGE POWER SUPPLY, 1/3.....	1
PCB 158H - LOW VOLTAGE POWER SUPPLY, 2/3.....	2
PCB 158H - LOW VOLTAGE POWER SUPPLY, 3/3.....	3
PCB 104D - KEYPAD / DISPLAY BOARD, 1/3.....	4
PCB 104D - KEYPAD / DISPLAY BOARD, 2/3.....	5
PCB 104D - KEYPAD / DISPLAY BOARD, 3/3.....	6
MAIN WIRING.....	7
<b>PERFORMANCE CHECK SHEET.....</b>	<b>0</b>

Manual Reference: /fileserver1/officefiles/instructword/avoz/AVOZ-F1-B,edition1.sxw.

Last modified February 29, 2024.

Copyright © 2024 Avtech Electrosystems Ltd, All Rights Reserved.

## INTRODUCTION

The AVOZ-F1-B is a voltage pulser designed to drive a 1.0 Ohm load impedance. The 1 Ohm impedance acts to limit the output current, and to terminate the 1 Ohm output transmission line. If the load is a diode, a resistance must be added in series with the diode so that the total resistance is 1 Ohm.

The output amplitude is variable from 0 to -180 Volts. The full-width half-maximum pulse width is fixed at 20 ns. The rise and fall times are approximately one-half of the pulse width (i.e., 10 ns). The repetition rate of the internal oscillator is variable from 0.1 to 100 Hz. (The instrument may also be triggered by an external TTL signal.)

A 0 to -50V DC variable offset may be applied to the output. The offset is connected through a 1 kilohm resistance, limiting the maximum offset current to 50 mA. This is provided to bias a laser diode just below threshold, if desired.

This model consists of an instrument mainframe and an output cable that consists of a unique 60 cm long, flexible microstrip line with a characteristic impedance of  $1\Omega$ . This allows the load to be placed away from the instrument without degrading rise time or the pulse shape. A matching resistor must be placed in series with the diode to provide a net resistive load to the line of 1 Ohm. Connection to the end of the line is normally by soldering (between the center conductor and ground) and the lines are supplied with one end soldered to a small piece of 1/16" glass epoxy circuit board (approx. 1 cm x 2.5 cm) with accessible output and ground solder pad areas. The other end of the AV-LZ cable is permanently connected to the rear-panel socket of the mainframe.

A delay control and a sync output are provided for oscilloscope triggering purposes. The sync output (a BNC connector located on front panel) provides a TTL pulse with 100 ns pulse width, and will drive 50 Ohms. The delay between the main output signal and the sync output is variable from 0 to 1.0 seconds.

This model includes a complete computer control interface. This provides GPIB and RS-232 computer-control, as well as front panel keypad and adjust knob control of the output pulse parameters. A large back-lit LCD displays the output amplitude, frequency, and delay. To allow easy integration into automated test systems, the programming command set is based on the SCPI standard, and sample LabView drivers are available for download at the Avtech web site ([www.avtechpulse.com](http://www.avtechpulse.com)).

This instrument is intended for use in research and development laboratories.

## SPECIFICATIONS

Model:	AVOZ-F1-B <sup>1</sup>
Amplitude:      voltage: current:	0 to -180 Volts 0 to -180 Amps
Polarity:	Negative
Required load impedance:	1.0 Ohms
Pulse width (FWHM):	20 ns (fixed)
Rise time (20% - 80%):	< 10 ns
Fall time (80% - 20%):	< 10 ns
PRF:      internally triggered: externally triggered:	0.1 to 100 Hz 0 to 100 Hz
DC offset:	0 to -50 Volts DC, variable. 50 mA maximum. Connected to the output through a 1 kilohm resistance.
GPIO and RS-232 control:	Included. See <a href="http://www.avtechpulse.com/gpib">http://www.avtechpulse.com/gpib</a> for details.
LabView drivers:	Check <a href="http://www.avtechpulse.com/labview">http://www.avtechpulse.com/labview</a> for availability and downloads
Propagation delay:	≤ 150 ns (Ext trig in to start of output pulse)
Jitter (Ext trig in to pulse out):	± 35ps ± 0.015% RMS (sync out to pulse out)
Trigger required (ext trig mode):	TTL levels (0 and +3V to +5V), 50 ns or wider
Sync delay:	Variable 0 to ± 1.0 seconds
Sync output:	TTL levels (0 and +3V to +5V), 100 ns width, will drive 50 Ohm loads
Gate input:	Synchronous, active high or low, switchable. Suppresses triggering when active.
Output transmission line: length: characteristic impedance (Z <sub>0</sub> )	Flexible AV-LZ1 microstrip <sup>2</sup> 60 cm 1 Ohm
Output connection:	Solder pads on the end of the flexible microstrip transmission line
Other signal connectors:	Trig, Gate: BNC (rear panel) Sync: BNC (front panel)
Power requirements:	100 - 240 Volts, 50 - 60 Hz
Dimensions: (H x W x D)	100 mm x 430 mm x 475 mm (3.9" x 17" x 18.8")
Chassis material:	cast aluminum frame and handles, blue vinyl on aluminum cover plates
Temperature range:	+5°C to +40°C

1) -B suffix indicates IEEE-488.2 GPIO and RS-232 control of amplitude, pulse width, PRF and delay (See <http://www.avtechpulse.com/gpib/>).

2) See <http://www.avtechpulse.com/transmission/av-lz1> for details.

## EUROPEAN REGULATORY NOTES

### EC DECLARATION OF CONFORMITY

We

Avtech Electrosystems Ltd.  
P.O. Box 5120, LCD Merivale  
Ottawa, Ontario  
Canada K2C 3H4

declare that this pulse generator meets the intent of Directive 89/336/EEC for Electromagnetic Compatibility. Compliance pertains to the following specifications as listed in the official Journal of the European Communities:

EN 50081-1 Emission

EN 50082-1 Immunity

and that this pulse generator meets the intent of the Low Voltage Directive 72/23/EEC as amended by 93/68/EEC. Compliance pertains to the following specifications as listed in the official Journal of the European Communities:

EN 61010-1:2001 Safety requirements for electrical equipment for measurement, control, and laboratory use



### DIRECTIVE 2002/95/EC (RoHS)

This instrument is exempt from Directive 2002/95/EC of the European Parliament and of the Council of 27 January 2003 on the Restriction of the use of certain Hazardous Substances (RoHS) in electrical and electronic equipment. Specifically, Avtech instruments are considered "Monitoring and control instruments" (Category 9) as defined in Annex 1A of Directive 2002/96/EC. The Directive 2002/95/EC only applies to Directive 2002/96/EC categories 1-7 and 10, as stated in the "Article 2 - Scope" section of Directive 2002/95/EC.

## INSTALLATION

### VISUAL CHECK

After unpacking the instrument, examine to ensure that it has not been damaged in shipment. Visually inspect all connectors, knobs, liquid crystal displays (LCDs), and the handles. Confirm that a power cord, a GPIB cable, and two instrumentation manuals (this manual and the “Programming Manual for -B Instruments”) are with the instrument. If the instrument has been damaged, file a claim immediately with the company that transported the instrument.

### POWER RATINGS

This instrument is intended to operate from 100 - 240 V, 50 - 60 Hz.

The maximum power consumption is 57 Watts. Please see the “FUSES” section for information about the appropriate AC and DC fuses.

This instrument is an “Installation Category II” instrument, intended for operation from a normal single-phase supply.

### CONNECTION TO THE POWER SUPPLY

An IEC-320 three-pronged recessed male socket is provided on the back panel for AC power connection to the instrument. One end of the detachable power cord that is supplied with the instrument plugs into this socket. The other end of the detachable power cord plugs into the local mains supply. Use only the cable supplied with the instrument. The mains supply must be earthed, and the cord used to connect the instrument to the mains supply must provide an earth connection. (The supplied cord does this.)

 Warning: Failure to use a grounded outlet may result in injury or death due to electric shock. This product uses a power cord with a ground connection. It must be connected to a properly grounded outlet. The instrument chassis is connected to the ground wire in the power cord.

The table below describes the power cord that is normally supplied with this instrument, depending on the destination region:



Destination Region	Description	Manufacturer	Part Number
Continental Europe	European CEE 7/7 "Schuko" 230V, 50Hz	Volex ( <a href="http://www.volex.com">http://www.volex.com</a> )	17850-C3-326
		Qualtek ( <a href="http://www.qualtekusa.com">http://www.qualtekusa.com</a> )	319004-T01
United Kingdom	BS 1363, 230V, 50Hz	Qualtek ( <a href="http://www.qualtekusa.com">http://www.qualtekusa.com</a> )	370001-E01
Switzerland	SEV 1011, 2 30V, 50Hz	Volex ( <a href="http://www.volex.com">http://www.volex.com</a> )	2102H-C3-10
Israel	SI 32, 220V, 50Hz	Volex ( <a href="http://www.volex.com">http://www.volex.com</a> )	2115H-C3-10
North America, and all other areas	NEMA 5-15, 120V, 60 Hz	Qualtek ( <a href="http://www.qualtekusa.com">http://www.qualtekusa.com</a> )	312007-01

## PROTECTION FROM ELECTRIC SHOCK

 Operators of this instrument must be protected from electric shock at all times. The owner must ensure that operators are prevented access and/or are insulated from every connection point. In some cases, connections must be exposed to potential human contact. Operators must be trained to protect themselves from the risk of electric shock. This instrument is intended for use by qualified personnel who recognize shock hazards and are familiar with safety precautions required to avoid possibly injury. In particular, operators should:

- 1) Keep exposed high-voltage wiring to an absolute minimum.
- 2) Wherever possible, use shielded connectors and cabling.
- 3) Connect and disconnect loads and cables only when the instrument is turned off.
- 4) Keep in mind that all cables, connectors, oscilloscope probes, and loads must have an appropriate voltage rating.
- 5) Do not attempt any repairs on the instrument, beyond the fuse replacement procedures described in this manual. Contact Avtech technical support (see page 2 for contact information) if the instrument requires servicing. Service is to be performed solely by qualified service personnel.

## ENVIRONMENTAL CONDITIONS

This instrument is intended for use under the following conditions:

1. indoor use;
2. altitude up to 2 000 m;
3. temperature 5 °C to 40 °C;

4. maximum relative humidity 80 % for temperatures up to 31 °C decreasing linearly to 50 % relative humidity at 40 °C;
5. Mains supply voltage fluctuations up to  $\pm 10$  % of the nominal voltage;
6. no pollution or only dry, non-conductive pollution.

## FUSES

This instrument contains four fuses. All are accessible from the rear-panel. Two protect the AC prime power input, and two protect the internal DC power supplies. The locations of the fuses on the rear panel are shown in the figure below:

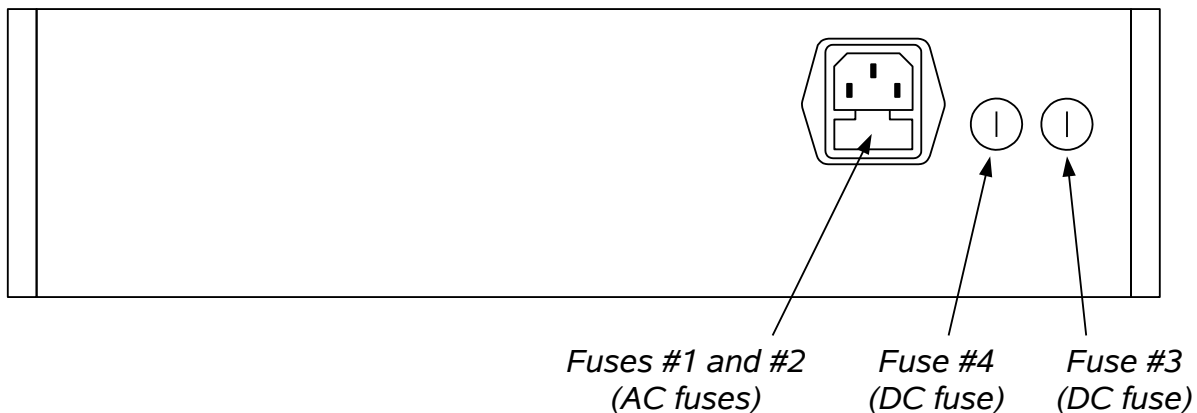

### AC FUSE REPLACEMENT

To physically access the AC fuses, the power cord must be detached from the rear panel of the instrument. The fuse drawer may then be extracted using a small flat-head screwdriver, as shown below:

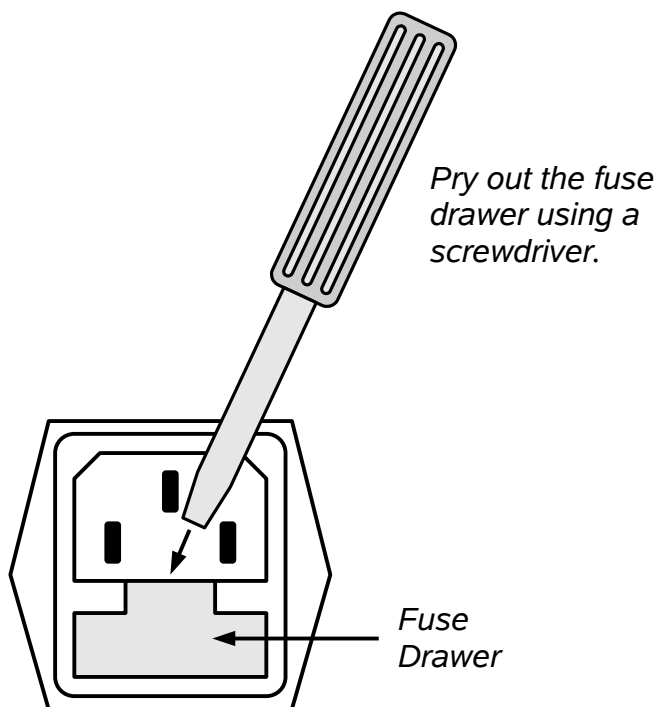

## DC FUSE REPLACEMENT

The DC fuses may be replaced by inserting the tip of a flat-head screwdriver into the fuse holder slot, and rotating the slot counter-clockwise. The fuse and its carrier will then pop out.

## FUSE RATINGS

The following table lists the required fuses:

Fuses	Nominal Mains Voltage	Rating	Case Size	Manufacturer's Part Number (Wickmann)	Distributor's Part Number (Digi-Key)
#1, #2 (AC)	100-240V	0.5A, 250V, Time-Delay	5×20 mm	1950500000	WK5041-ND
#3 (DC)	N/A	1.0A, 250V, Time-Delay	5×20 mm	1951100000	WK5048-ND
#4 (DC)	N/A	0.25A, 250V, Time-Delay	5×20 mm	1950250000	WK5035-ND

The fuse manufacturer is Wickmann (<http://www.wickmann.com/>).

Replacement fuses may be easily obtained from Digi-Key (<http://www.digikey.com/>) and other distributors.

## FRONT PANEL CONTROLS

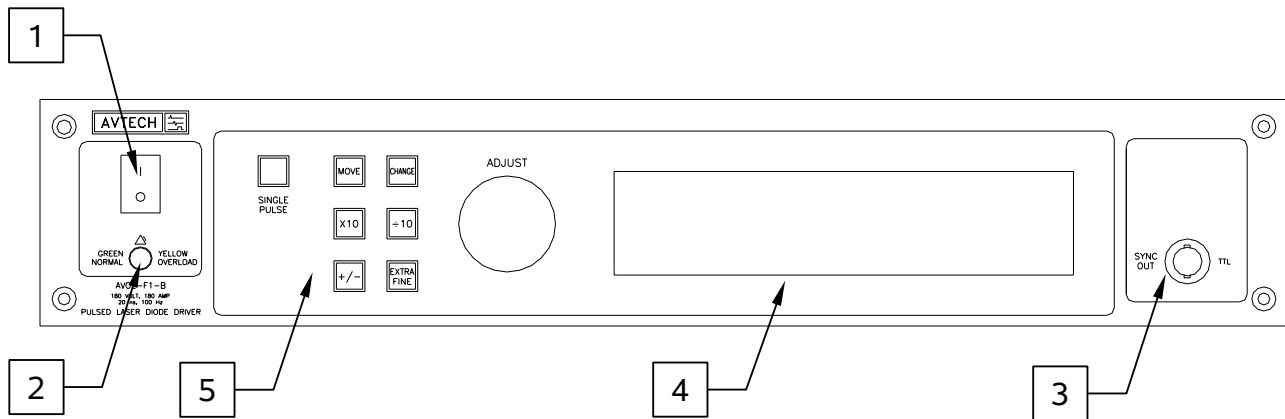

1. POWER Switch. This is the main power switch. When turning the instrument on, there may be a delay of several seconds before the instrument appears to respond.
2. OVERLOAD Indicator. When the instrument is powered, this indicator is normally green, indicating normal operation. If this indicator is yellow, an internal automatic overload protection circuit has been tripped. If the unit is overloaded (by operating at an exceedingly high duty cycle or by operating into a very low impedance), the protective circuit will disable the output of the instrument and turn the indicator light yellow. The light will stay yellow (i.e. output disabled) for about 5 seconds after which the instrument will attempt to re-enable the output (i.e. light green) for about 1 second. If the overload condition persists, the output will be disabled again (i.e. light yellow) for another 5 seconds. If the overload condition has been removed, the instrument will resume normal operation.

This overload indicator may flash yellow briefly at start-up. This is not a cause for concern.

Note that the output stage will safely withstand a short-circuited load condition.

3. SYNC OUT. This connector supplies a SYNC output that can be used to trigger other equipment, particularly oscilloscopes. This signal leads (or lags) the main output by a duration set by the "DELAY" controls and has an approximate amplitude of +3 Volts to  $R_L > 1 \text{ k}\Omega$  with a pulse width of approximately 100 ns.
4. LIQUID CRYSTAL DISPLAY (LCD). This LCD is used in conjunction with the keypad to change the instrument settings. Normally, the main menu is displayed, which lists the key adjustable parameters and their current values. The "Programming Manual for -B Instruments" describes the menus and submenus in detail.

5. KEYPAD.

Control Name	Function
MOVE	This moves the arrow pointer on the display.
CHANGE	This is used to enter the submenu, or to select the operating mode, pointed to by the arrow pointer.
×10	If one of the adjustable numeric parameters is displayed, this increases the setting by a factor of ten.
÷10	If one of the adjustable numeric parameters is displayed, this decreases the setting by a factor of ten.
+/-	If one of the adjustable numeric parameters is displayed, and this parameter can be both positive or negative, this changes the sign of the parameter.
EXTRA FINE	This changes the step size of the ADJUST knob. In the extra-fine mode, the step size is twenty times finer than in the normal mode. This button switches between the two step sizes.
ADJUST	This large knob adjusts the value of any displayed numeric adjustable values, such as frequency, pulse width, etc. The adjust step size is set by the "EXTRA FINE" button.  When the main menu is displayed, this knob can be used to move the arrow pointer.

## REAR PANEL CONTROLS

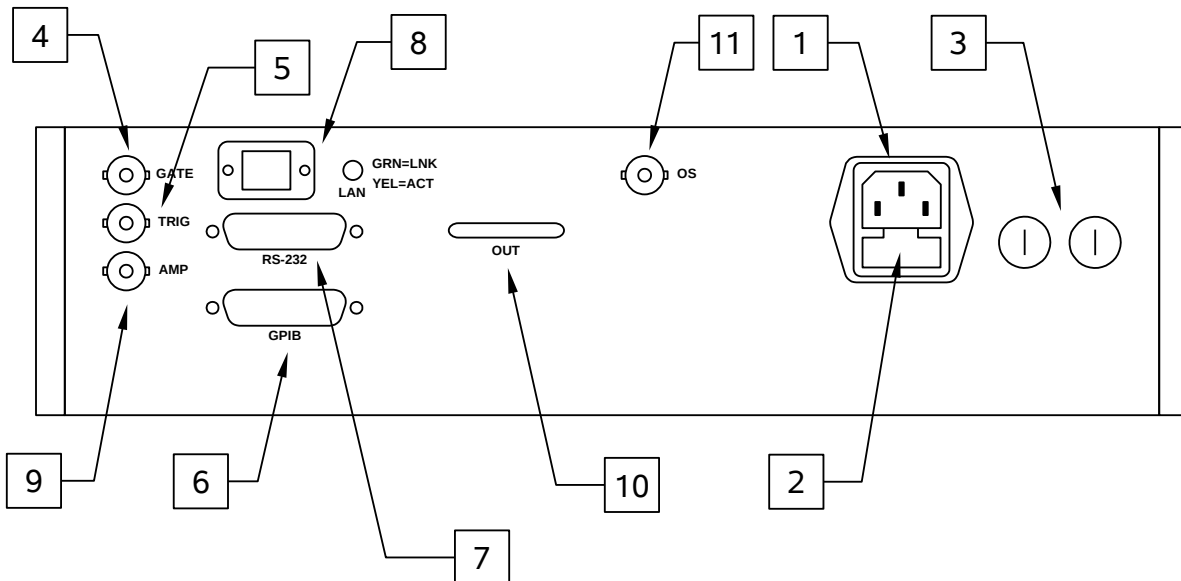

1. **AC POWER INPUT.** An IEC-320 C14 three-pronged recessed male socket is provided on the back panel for AC power connection to the instrument. One end of the detachable power cord that is supplied with the instrument plugs into this socket.
2. **AC FUSE DRAWER.** The two fuses that protect the AC input are located in this drawer. Please see the “FUSES” section of this manual for more information.
3. **DC FUSES.** These two fuses protect the internal DC power supplies. Please see the “FUSES” sections of this manual for more information.
4. **GATE.** This TTL-level (0 and +5V) logic input can be used to gate the triggering of the instrument. This input can be either active high or active low, depending on the front panel settings or programming commands. (The instrument triggers normally when this input is unconnected). When set to active high mode, this input is pulled-down to ground by a 1 k $\Omega$  resistor. When set to active low mode, this input is pulled-up to +5V by a 1 k $\Omega$  resistor.
5. **TRIG.** This TTL-level (0 and +5V) logic input can be used to trigger the instrument, if the instrument is set to triggering externally. The instrument triggers on the rising edge of this input. The input impedance of this input is 1 k $\Omega$ . (Depending on the length of cable attached to this input, and the source driving it, it may be desirable to add a coaxial 50 Ohm terminator to this input to provide a proper transmission line termination. The Pasternack ([www.pasternack.com](http://www.pasternack.com)) PE6008-50 BNC feed-thru 50 Ohm terminator is suggested for this purpose.)

When triggering externally, the instrument can be set such that the output pulse width tracks the pulse width on this input, or the output pulse width can be set

independently.

6.  GPIB Connector. A standard GPIB cable can be attached to this connector to allow the instrument to be computer-controlled. See the “Programming Manual for -B Instruments” for more details on GPIB control.
7.  RS-232 Connector. A standard serial cable with a 25-pin male connector can be attached to this connector to allow the instrument to be computer-controlled. See the “Programming Manual for -B Instruments” for more details on RS-232 control.
8.  LAN Connector and Indicator. (Optional feature. Present on -TNT units only.) The -TNT option "Internet-enables" Avtech pulse generators by adding this standard Ethernet port to the rear panel, in addition to the IEEE-488.2 GPIB and RS-232 ports normally found on "-B" units. Commands are sent using the standard Telnet protocol. The SCPI-compliant command set is the same as that used for GPIB and RS-232 control. The -TNT option uses the Dynamic Host Configuration Protocol (DHCP) to obtain its network address. A DHCP server must be present on the local network for the -TNT option to operate properly.
9.  AMP Connector. (Active on units with the -EA option only.) The output amplitude can be set to track the voltage on this input. Zero Volts in corresponds to zero amplitude output, and +10V in corresponds to maximum amplitude out. This mode is activated by selecting "Ext Control" on the front-panel amplitude menu, or with the "source:voltage external" command.
10.  OUT. The LZ1 output transmission line emerges from the instrument at this location. The load is connected to the end of this transmission line.  
  
 Caution: Voltages as high as 500V may be present on the signal conductor of this output transmission line. Do not touch any area where the protective kapton insulation has been removed.
11.  OS Connector. An offset in the range of 0 to -50V may be applied to this input. This DC offset is applied to the output through a 1 kilohm input impedance and a 470 uH inductance.



## GENERAL INFORMATION

### BASIC PULSE CONTROL

This instrument can be triggered by its own internal clock or by an external TTL trigger signal. In either case, two output channels respond to the trigger: OUT and SYNC. The OUT channel is the signal that is applied to the device under test. Its amplitude and pulse width are variable. The SYNC pulse is a fixed-width TTL-level reference pulse used to trigger oscilloscopes or other measurement systems. When the delay is set to a positive value the SYNC pulse precedes the OUT pulse.

In the diagrams below, positive amplitude is assumed. (For “-N” units, the output waveforms are inverted in polarity.)

These pulses are illustrated below for a positive delay, and internal triggering:

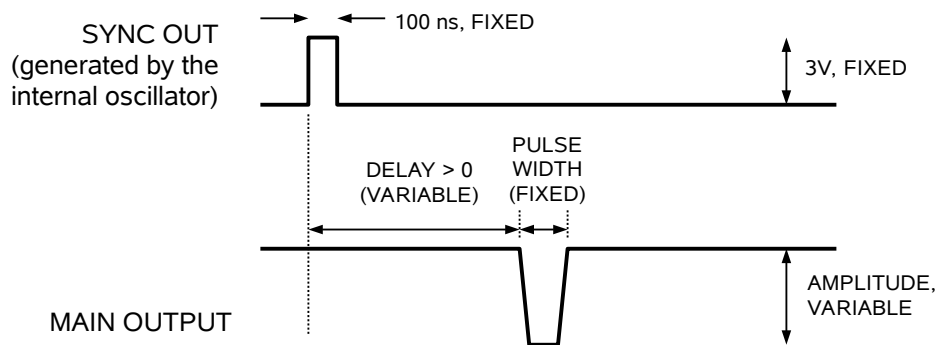

*Basic Output Pulses for Delay > 0*

The order of the output pulses is reversed for negative delays:

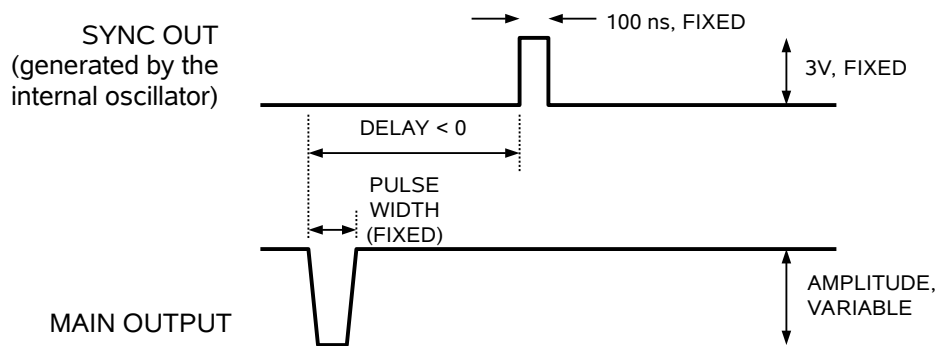

*Basic Output Pulses for Delay < 0*

When the triggering is set to external mode, a TTL-level pulse on the TRIG input will trigger the pulse generator, as shown below:

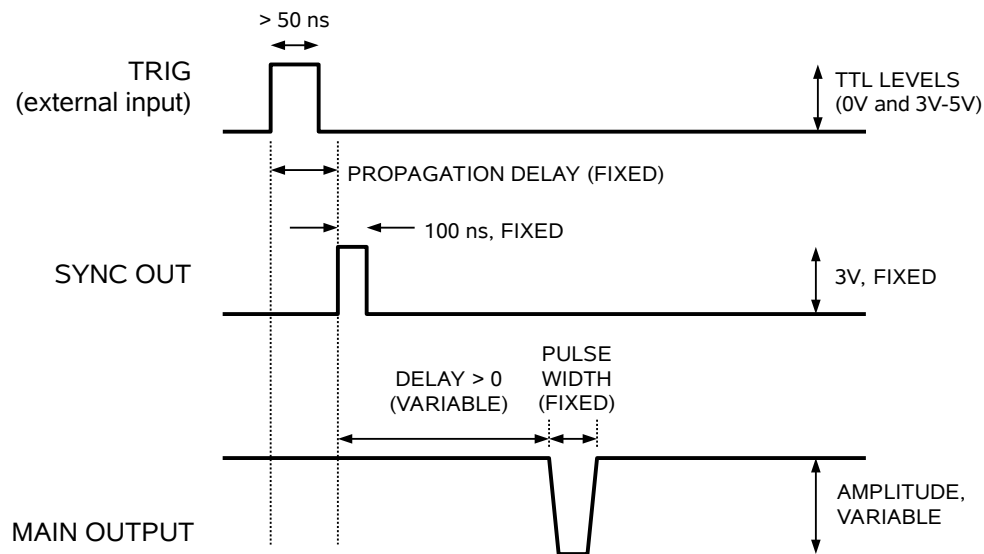

As before, if the delay is negative, the order of the SYNC and OUT pulses is reversed.

## TRIGGER MODES

This instrument has four trigger modes:

- Internal Trigger: the instrument controls the trigger frequency, and generates the clock internally.
- External Trigger: the instrument is triggered by an external TTL-level clock on the back-panel TRIG connector.
- Manual Trigger: the instrument is triggered by the front-panel “SINGLE PULSE” pushbutton.
- Hold Trigger: the instrument is set to not trigger at all.

These modes can be selected using the front panel trigger menu, or by using the appropriate programming commands. (See the “OP1B Interface Programming Manual” for more details.)

## GATING MODES

Triggering can be suppressed by a TTL-level signal on the rear-panel GATE connector. The instrument can be set to stop triggering when this input high or low, using the front-panel gate menu or the appropriate programming commands.

## GENERAL INFORMATION - OPERATING INTO A LOAD

### AMPLITUDE CONTROL

The Model AVOZ-F1-B pulse generator is a voltage pulser with an output impedance of approximately 1 Ohm. The current amplitude is determined by Ohm's Law. That is, the current is the output voltage divided by the load resistance. More specifically:

$$I_{OUT} \approx (V_{SETTING} - V_{DIODE}) / 1.0\Omega,$$

where  $V_{SETTING}$  is the set amplitude,  $V_{DIODE}$  is the diode voltage, assuming that the load resistance is 1.0Ω. The load resistance should normally be 1.0Ω, to provide a proper termination for the LZ1 output transmission line, which has a characteristic impedance ( $Z_0$ ) of 1Ω.

Load resistances greater than 1.0Ω may be used if desired. This will cause the output voltage to be somewhat higher than the programmed setting, however. The maximum output current will decrease. Increased transmission line reflections may also be observed.

### DESIGNING THE SERIES RESISTANCE

The 1Ω load resistance must be able to withstand the maximum peak current (-180 Amps) for 20 ns, and must have extremely low parasitic inductance.

In practice, most carbon film, carbon composition, and ceramic composition resistors can withstand 180A peak currents for 20 ns pulses.

To ensure a low parasitic inductance in the load, several low-inductance resistors should be used in parallel. (Connecting resistors in parallel will also have the beneficial effect of lower the maximum peak current in each resistor.) Factory tests are conducted using four RCD RSF1A 4.7 Ohm resistors and one RSF1A 8.2 Ohm resistor in parallel, for a total resistance of approximately 1.03 Ohms. (For more information about these resistors, please see the manufacturer's web site at <http://www.rcd-comp.com>.)

### USING THE LZ1 OUTPUT LINE

A flexible, low-characteristic-impedance transmission line is supplied with this instrument. One end is permanently connected to the rear panel of the instrument, and the other end is terminated with a 1.0 × 2.5 cm section of glass epoxy circuit board.

The load may be soldered to the circuit board end. The circuit board layout is illustrated below:

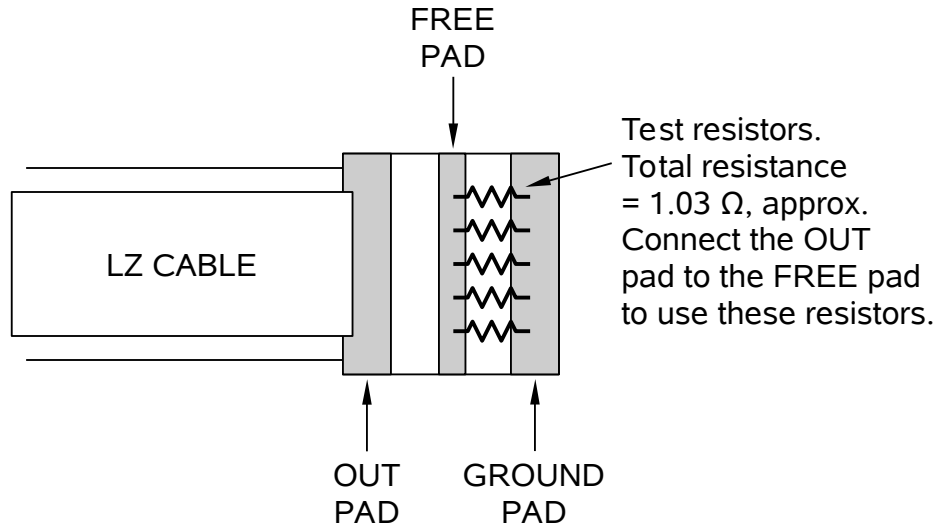

The output board is supplied with four RCD RSF1A 4.7 Ohm resistors and one RSF1A 8.2 Ohm resistor in parallel installed between the free pad and the ground pad, to enable the end-user to duplicate factory tests. To use these resistors, solder a short wire between the out pad and the free pad, so that the output is connected to the resistors. If desired, a current probe may be installed on this short wire. (Keep the wire as short as possible - less than 1 cm in length. Use a heavy-gauge wire, such as #18 AWG, if possible).

The length of leads used to connect the load to the circuit board should be kept extremely short (< 0.5 cm), as discussed below.

 **Caution:** Voltages as high as 500V may be present on the signal conductor of this output transmission line. Do not touch any area where the protective kapton insulation has been removed.

### HANDLING AND STORING THE LZ1 OUTLINE LINE

 **Treat the LZ1 line very gently - if it is damaged, the entire instrument must be returned to the factory for repair!**

For storage purposes, the LZ1 line can be folded once (approximately 10 inches / 25 cm from the output board) and gently inserted into the clear plastic sleeve on top of the instrument. This is shown in the photo below:



The LZ1 may be removed from the storage sleeve by gently pulling on it from the rear of the instrument.

### LENZ'S LAW AND INDUCTIVE VOLTAGE SPIKES

This instrument is designed to pulse resistive and diode loads and will exhibit a large output spike when used to drive a load with significant inductance (as predicted by LENZ'S LAW). For this reason the load should be connected to the output using low inductance leads (as short as possible and as heavy a gauge as possible).

The voltage developed across an inductance  $L$  (in Henries), when the current is changing at a rate given by  $di_{LOAD}/dt$  (in Amps/sec), is:  $V_{SPIKE} = L \times di_{LOAD}/dt$ .

For this reason, the length of leads used to connect the load to the circuit board should be kept extremely short ( $< 0.5$  cm).

### ATTACHING AND DETACHING LOADS

To avoid damaging the loads connected to main outputs, the loads should only be connected to or removed from the instrument when the instrument is off. Do not connect loads when the instrument is on and the output amplitude is not zero. This can cause sparking.

## TEST ARRANGEMENT

The recommended test arrangement is shown below:

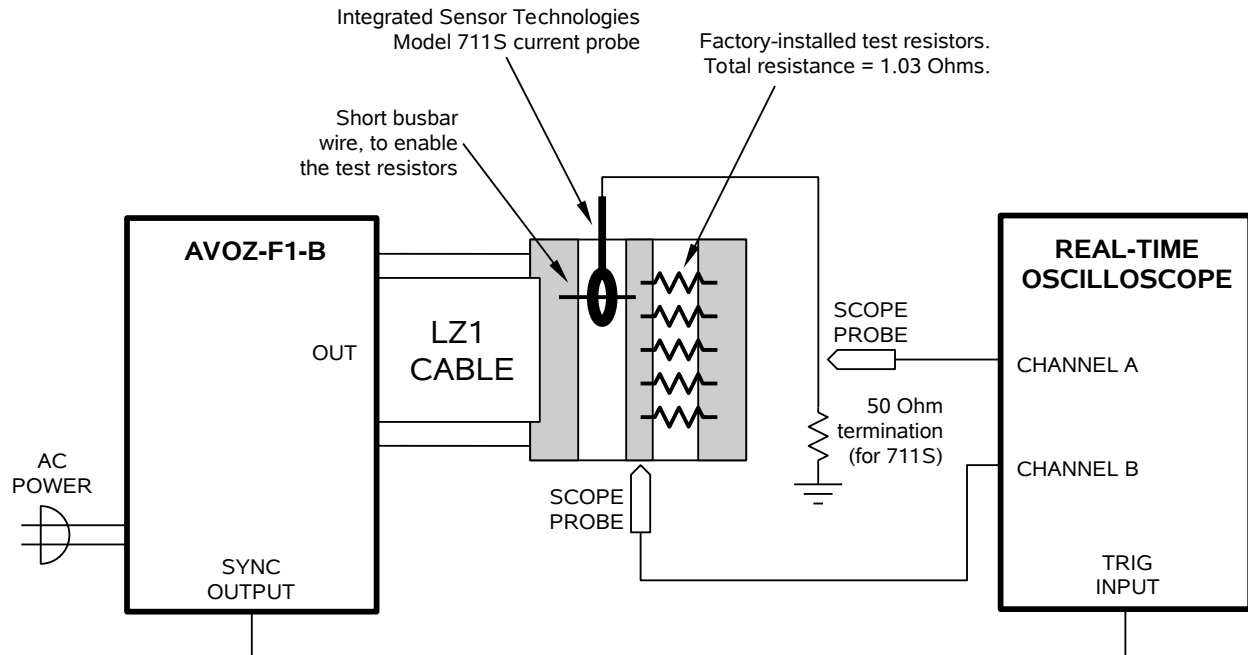

The output board is supplied with four RCD RSF1A 4.7 Ohm resistors and one RSF1A 8.2 Ohm resistor in parallel installed between the free pad and the ground pad, to enable the end-user to duplicate factory tests. To use these resistors, solder a short wire between the out pad and the free pad, so that the output is connected to the resistors. If desired, a current probe may be installed on this short wire. The Integrated Sensor Technologies (<http://www.isensortech.com/>) Model 711S current probe is recommended for this application.

A current probe will normally give higher-accuracy measurements than observing the voltage waveform across the resistors. The parasitic inductance in the resistors distorts the voltage waveforms slightly, making them not-quite proportional to the current waveform.

The length of leads used to connect the load to the circuit board should be kept extremely short (< 0.5 cm), as discussed below.

A photograph of an actual setup in the area of the output board is shown below:

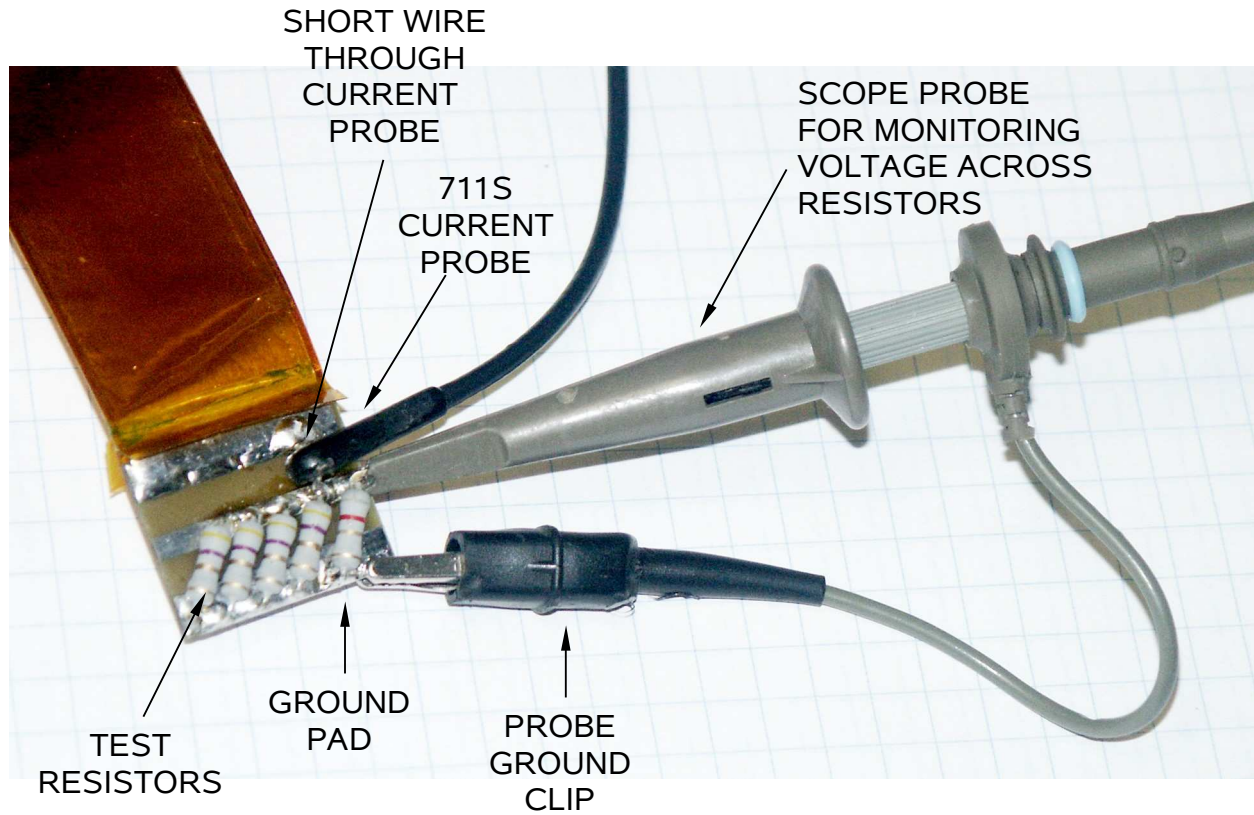

TYPICAL WAVEFORMS

Typical waveforms for the arrangement shown above are shown below:

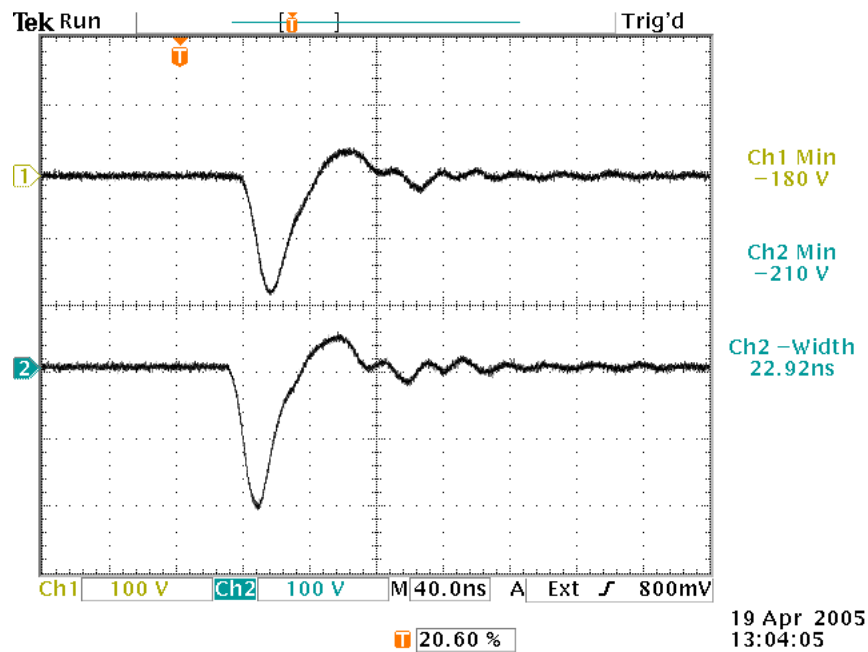

The top waveform is the output of the 711S current probe. When the probe is terminated with a 50 Ohm load, the probe generates 1 Volt per Amp. The bottom waveform is the voltage waveform across the 1.03 Ohm test resistance. The voltage amplitude is slightly higher than predicted by  $180\text{A} \times 1.03\Omega = 185\text{V}$ , due to the small but non-zero parasitic inductance of the resistors.

### AFTER-PULSE TRANSIENTS

A small positive-going pulse occurs after the main pulse, as shown in the typical waveforms above. The load must be able to withstand this reverse transient. Sensitive diode loads may need to be protected by a reverse-connected protection diode in parallel with the diode under test.

### DC OFFSET

A 0 to -50V DC variable offset may be applied to the output through a rear-panel BNC connector. The offset is connected through a 1 kilohm resistance, limiting the maximum offset current to 50 mA. This is provided to bias a laser diode just below threshold, if desired.

### HIGH-VOLTAGE PRECAUTIONS

 **CAUTION:** This instrument provides output voltages as high as 250 Volts when operating into a 1 Ohm load, and up to 500V when operating into open circuits, so extreme caution must be employed when using this instrument. The instrument should only be used by individuals who are thoroughly skilled in high voltage laboratory techniques. The following precaution should always be observed:

- 1) Keep exposed high-voltage wiring to an absolute minimum.
- 2) Wherever possible, use shielded connectors and cabling.
- 3) Connect and disconnect loads and cables only when the amplifier is turned off.
- 4) Keep in mind that all cables, connectors, oscilloscope probes, and loads must have an appropriate voltage rating.
- 5) Do not attempt any repairs on the instrument, beyond the fuse replacement procedures described in this manual. Contact Avtech technical support (see page 2 for contact information) if the instrument requires servicing.



## PROGRAMMING YOUR PULSE GENERATOR

### KEY PROGRAMMING COMMANDS

The “OP1B Interface Programming Manual” describes in detail how to connect the pulse generator to your computer, and the programming commands themselves. A large number of commands are available; however, normally you will only need a few of these. Here is a basic sample sequence of commands that might be sent to the instrument after power-up:

```
*rst                (resets the instrument)
trigger:source internal (selects internal triggering)
frequency 10 Hz      (sets the frequency to 10 Hz)
pulse:width 100 ns   (sets the pulse width to 100 ns)
pulse:delay 1 us     (sets the delay to 1 us)
output on            (turns on the output)
source:volt 35V      (sets the voltage amplitude to 35 Volts)
```

For triggering a single event, this sequence would be more appropriate:

```
*rst                (resets the instrument)
trigger:source hold  (turns off all triggering)
pulse:width 100 ns   (sets the pulse width to 100 ns)
output on            (turns on the output)
source:volt 35V      (sets the voltage amplitude to 35 Volts)
trigger:source immediate (generates a single non-repetitive trigger event)
trigger:source hold  (turns off all triggering)
output off           (turns off the output)
```

To set the instrument to trigger from an external TTL signal applied to the rear-panel TRIG connector, use:

```
*rst                (resets the instrument)
trigger:source external (selects external triggering)
pulse:width 100 ns     (sets the pulse width to 100 ns)
pulse:delay 1 us       (sets the delay to 1 us)
source:volt 35V        (sets the voltage amplitude to 35 Volts)
output on              (turns on the output)
```

These commands will satisfy 90% of your programming needs.

## ALL PROGRAMMING COMMANDS

For more advanced programmers, a complete list of the available commands is given below. These commands are described in detail in the “OP1B Interface Programming Manual”. (Note: this manual also includes some commands that are not implemented in this instrument. They can be ignored.)

<u>Keyword</u>	<u>Parameter</u>	<u>Notes</u>
DIAGnostic: :AMPLitude :CALibration:	<numeric value>	[no query form]
LOCAL MEASure: :AMPLitude?		[query only]
OUTPut: :[STATe] :PROTection :TRIPped?	<boolean value>	[query only]
REMOTE [SOURce]: :FREQuency [:CW   FIXed]	<numeric value>	
[SOURce]: :VOLTagE [:LEVel] [:IMMediate] [:AMPLitude]	<numeric value>	
:PROTection :TRIPped?		[query only]
[SOURce]: :PULSe :PERiod :WIDTh :DCYClE :HOLD :DELay :GATE :TYPE :LEVel	<numeric value> <numeric value> <numeric value> WIDTh   DCYClE <numeric value> ASYNc   SYNc HIgh   LOw	
STATUS: :OPERation :[EVENT]? :CONDition? :ENABle	<numeric value>	[query only, always returns "0"] [query only, always returns "0"] [implemented but not useful]
:QUEStionable :[EVENT]? :CONDition? :ENABle	<numeric value>	[query only, always returns "0"] [query only, always returns "0"] [implemented but not useful]
SYSTem: :COMMunicate :GPIB :ADDReSS :SERial :CONTRol	<numeric value>	

:RTS	ON   IBFull   RFR	
:[RECeive]		
:BAUD	1200   2400   4800   9600	
:BITS	7   8	
:ECHO	<boolean value>	
:PARity		
:[TYPE]	EVEN   ODD   NONE	
:SBITS	1   2	
:ERRor		
:[NEXT]?		[query only]
:COUNT?		[query only]
:VERSion?		[query only]
TRIGger:		
:SOURce	INTernal   EXTernal   MANual   HOLD   IMMEDIATE	
*CLS		[no query form]
*ESE	<numeric value>	
*ESR?		[query only]
*IDN?		[query only]
*OPC		
*SAV	0   1   2   3	[no query form]
*RCL	0   1   2   3	[no query form]
*RST		[no query form]
*SRE	<numeric value>	
*STB?		[query only]
*TST?		[query only]
*WAI		[no query form]

## MECHANICAL INFORMATION

### TOP COVER REMOVAL

If necessary, the interior of the instrument may be accessed by removing the four Phillips screws on the top panel. With the four screws removed, the top cover may be slid back (and off).

 Always disconnect the power cord and allow the instrument to sit unpowered for 10 minutes before opening the instrument. This will allow any internal stored charge to discharge.

There are no user-adjustable internal circuits. For repairs other than fuse replacement, please contact Avtech (info@avtechpulse.com) to arrange for the instrument to be returned to the factory for repair. Service is to be performed solely by qualified service personnel.

 Caution: High voltages are present inside the instrument during normal operation. Do not operate the instrument with the cover removed.

### RACK MOUNTING

A rack mounting kit is available. The -R5 rack mount kit may be installed after first removing the one Phillips screw on the side panel adjacent to the front handle.

### ELECTROMAGNETIC INTERFERENCE

To prevent electromagnetic interference with other equipment, all used outputs should be connected to shielded loads using shielded coaxial cables. Unused outputs should be terminated with shielded coaxial terminators or with shielded coaxial dust caps, to prevent unintentional electromagnetic radiation. All cords and cables should be less than 3m in length.

## MAINTENANCE

### REGULAR MAINTENANCE

This instrument does not require any regular maintenance.

On occasion, one or more of the four rear-panel fuses may require replacement. All fuses can be accessed from the rear panel. See the “FUSES” section for details.

### CLEANING

If desired, the interior of the instrument may be cleaned using compressed air to dislodge any accumulated dust. (See the “TOP COVER REMOVAL” section for instructions on accessing the interior.) No other cleaning is recommended.

# WIRING DIAGRAMS

## WIRING OF AC POWER

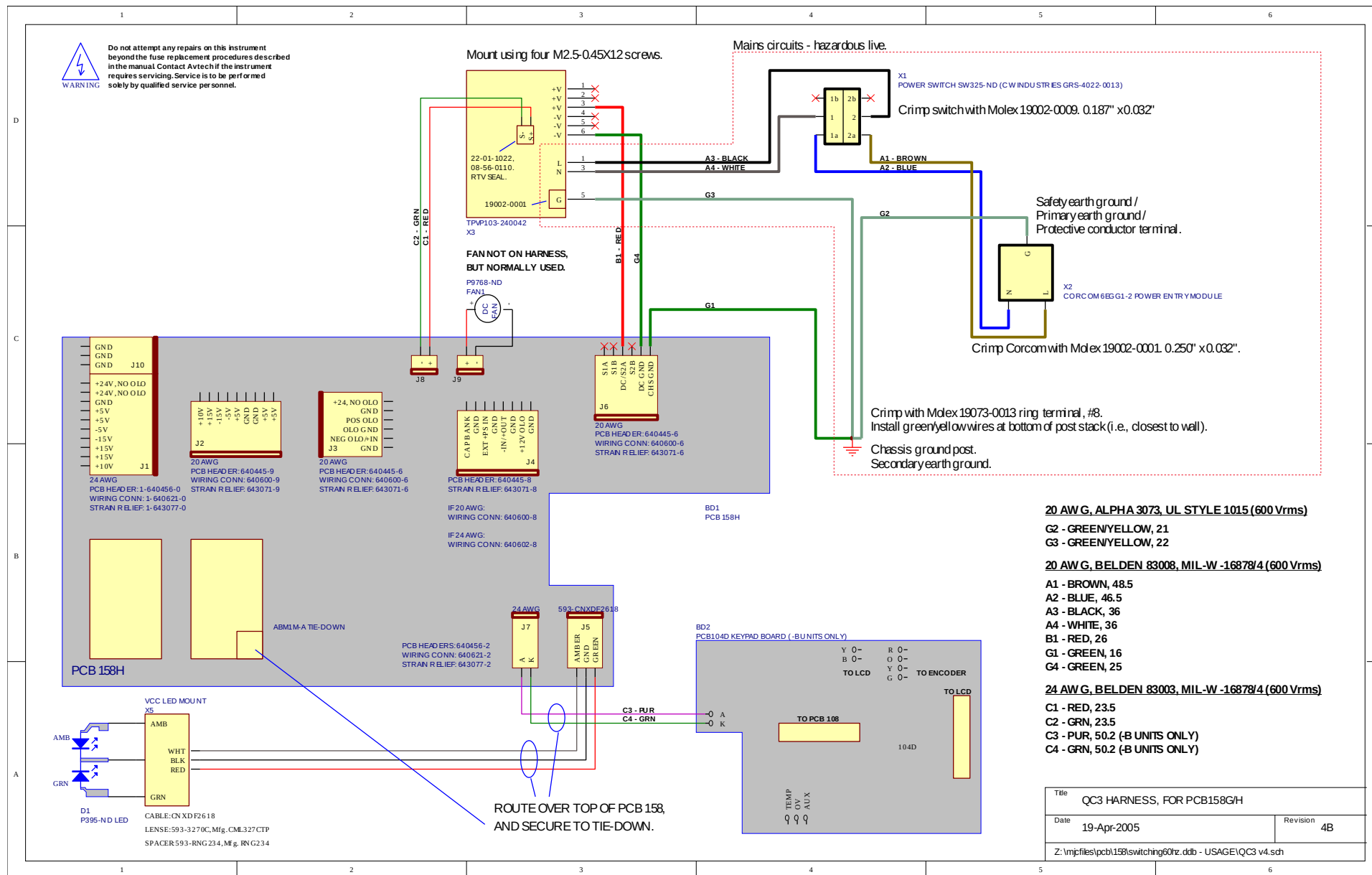

# PCB 158H - LOW VOLTAGE POWER SUPPLY, 1/3

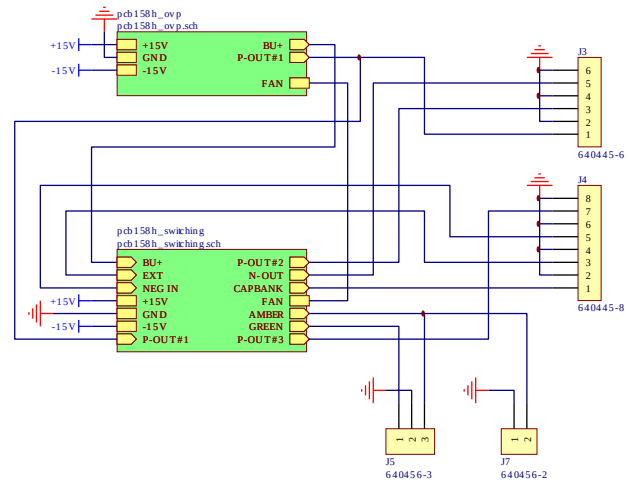

Title		LOW VOLTAGE DC/DC POWER SUPPLY
Date	19-Apr-2005	Revision
Z:\mpjfiles\pcb158\switching01rz.ddb - 158H\pcb158h.sch		

# PCB 158H - LOW VOLTAGE POWER SUPPLY, 2/3

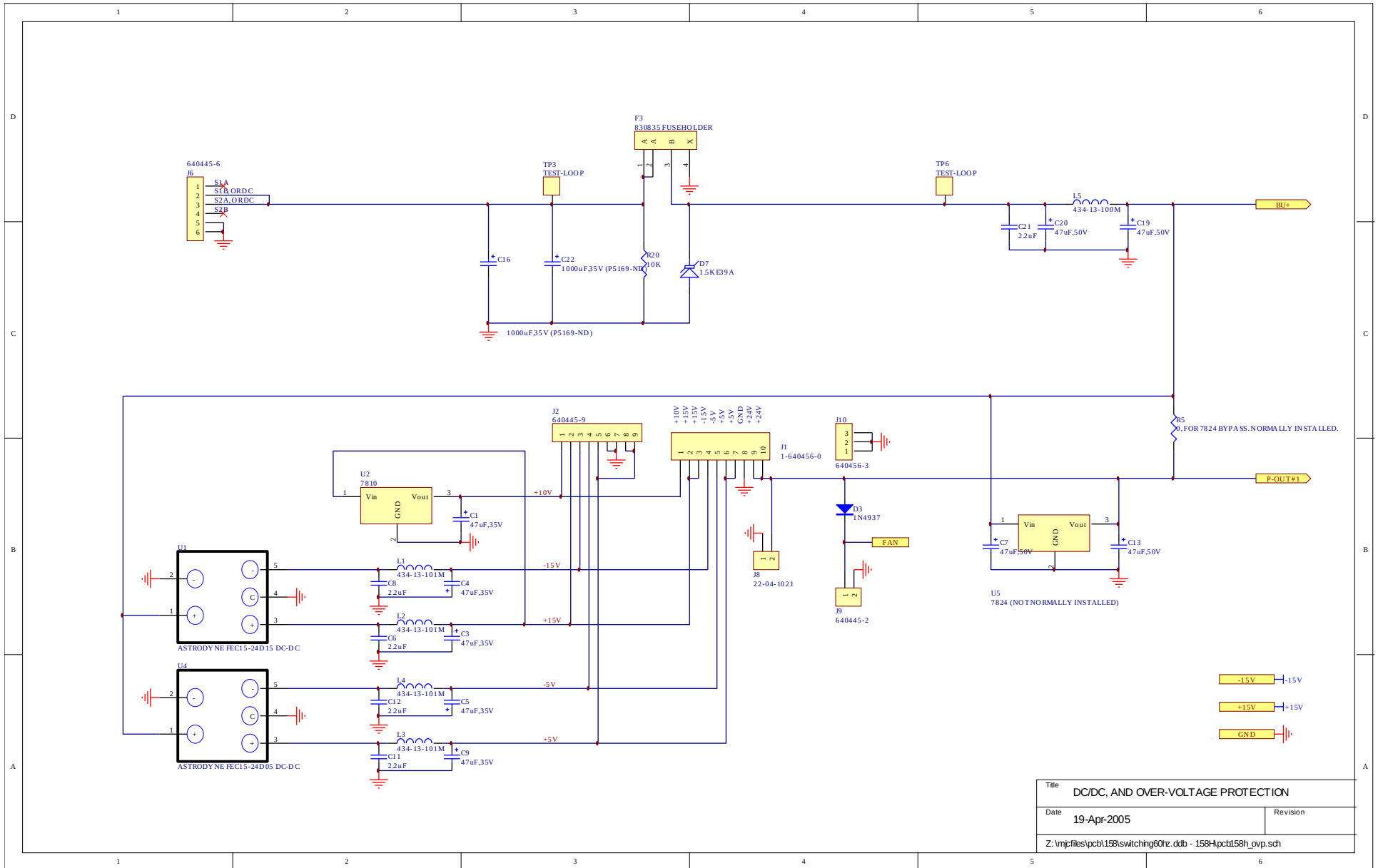

Title		DC/DC, AND OVER-VOLTAGE PROTECTION	
Date	19-Apr-2005	Revision	
Z:\m\pfiles\pcb158\switching01r2.ddb - 158H\pcb158h_ovp.sch			



# PCB 158H - LOW VOLTAGE POWER SUPPLY, 3/3

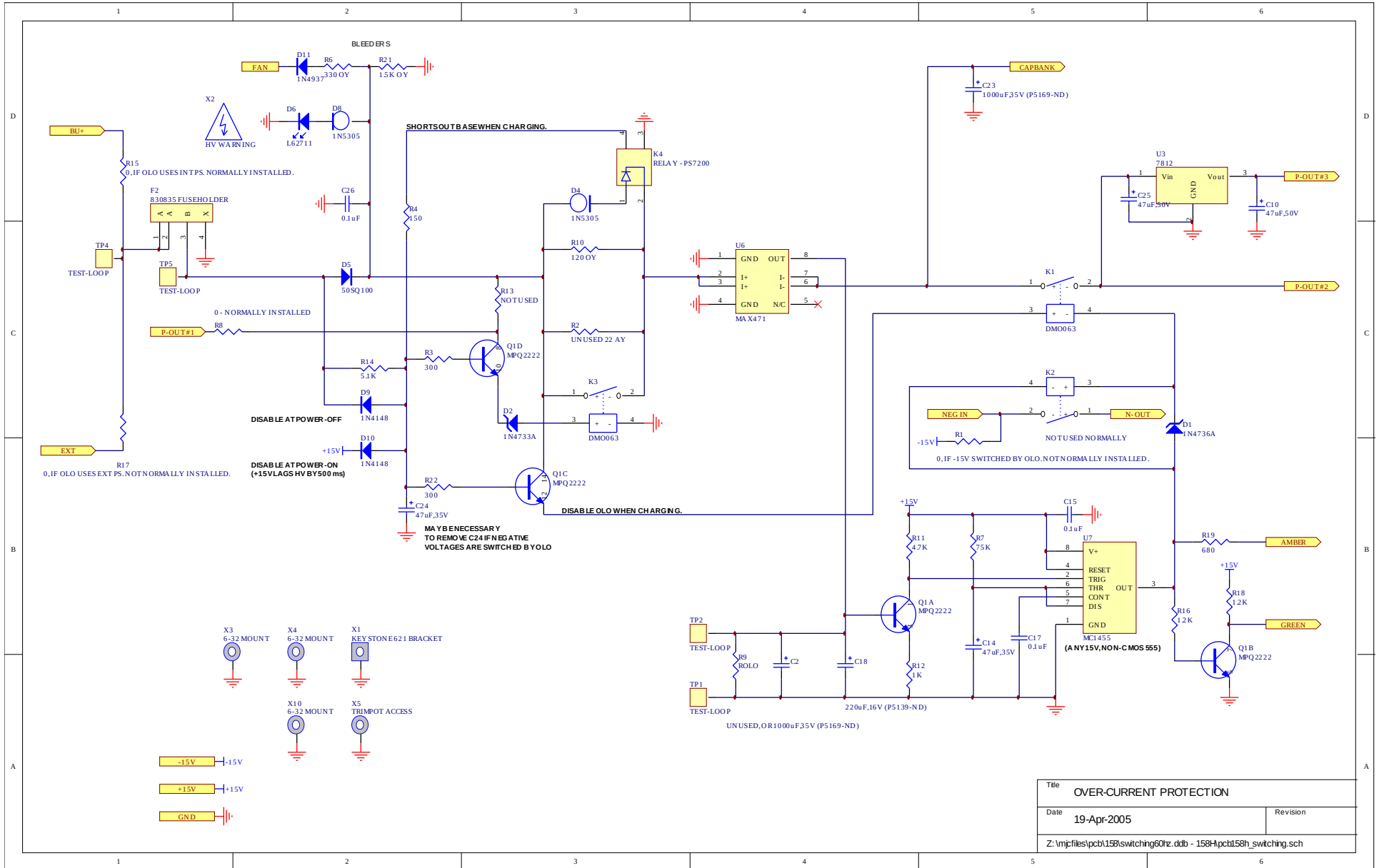

# PCB 104D - KEYPAD / DISPLAY BOARD, 1/3

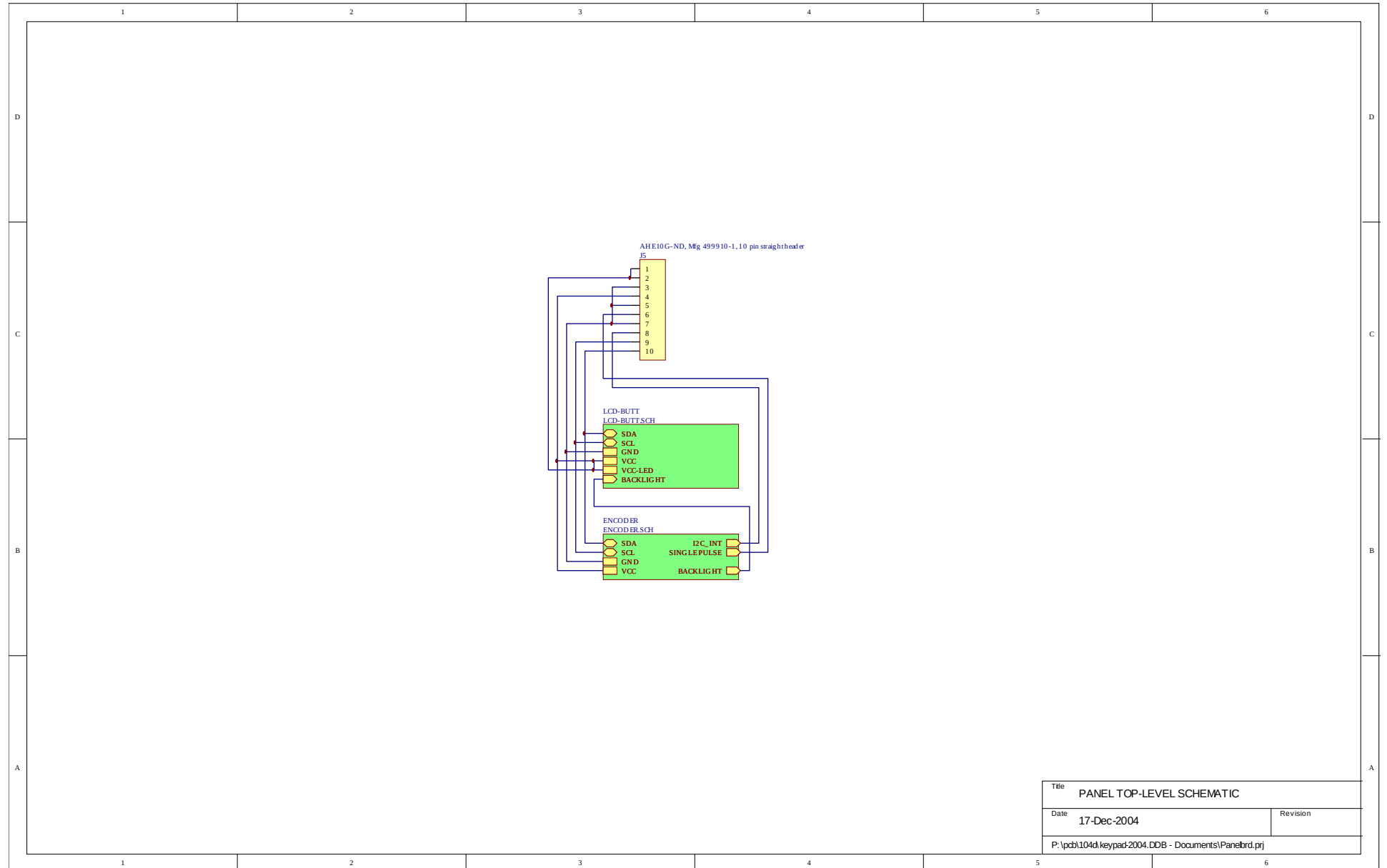

Title		PANEL TOP-LEVEL SCHEMATIC	
Date	17-Dec-2004	Revision	
P:\pcb\104d\keypad\2004.DDB - Documents\Panelbrd.prj			

# PCB 104D - KEYPAD / DISPLAY BOARD, 2/3

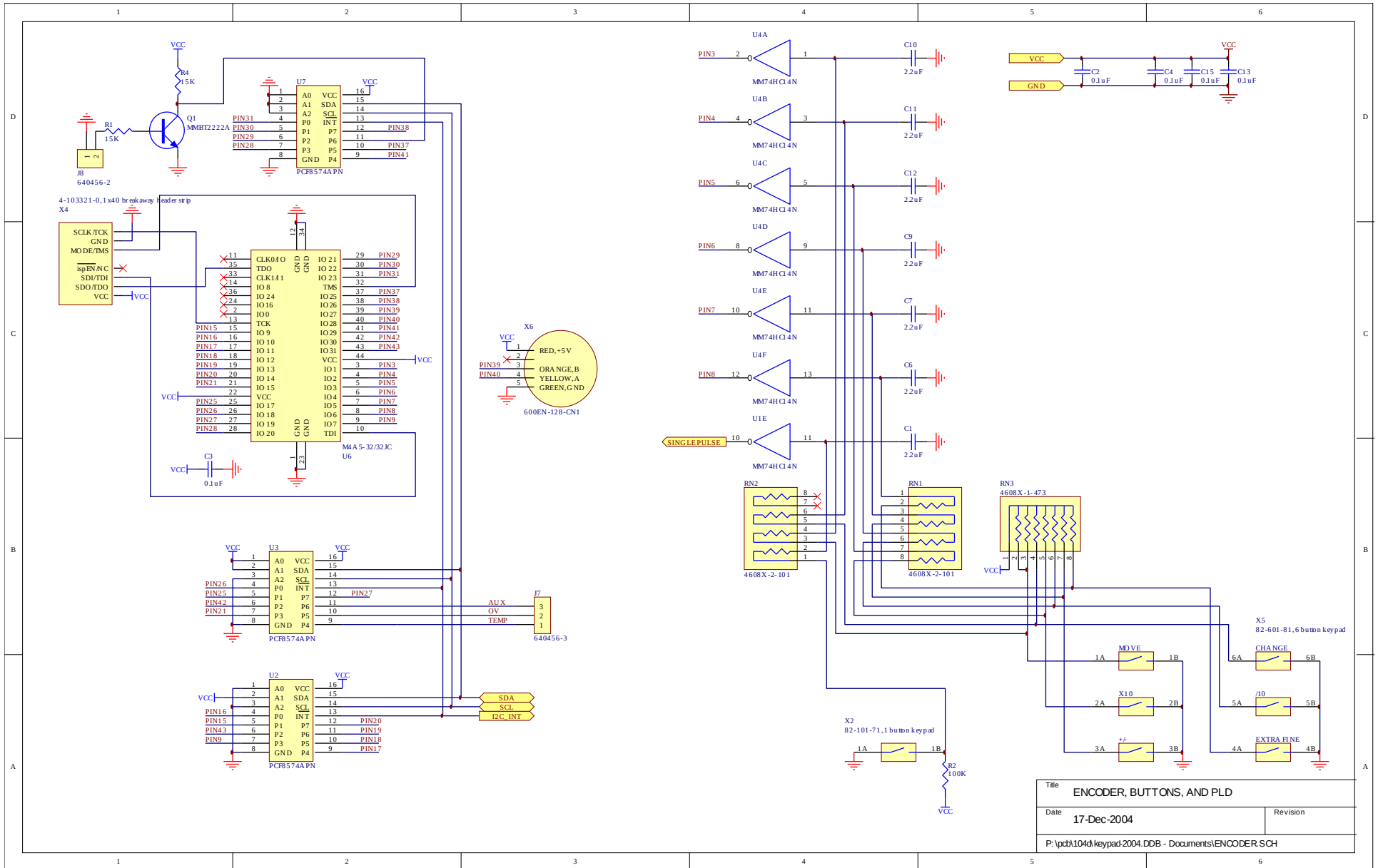

Title		ENCODER, BUTTONS, AND PLD
Date	17-Dec-2004	Revision
P:\pcb\104d\keypad\2004.DDB - Documents\ENCODER-SCH		

# PCB 104D - KEYPAD / DISPLAY BOARD, 3/3

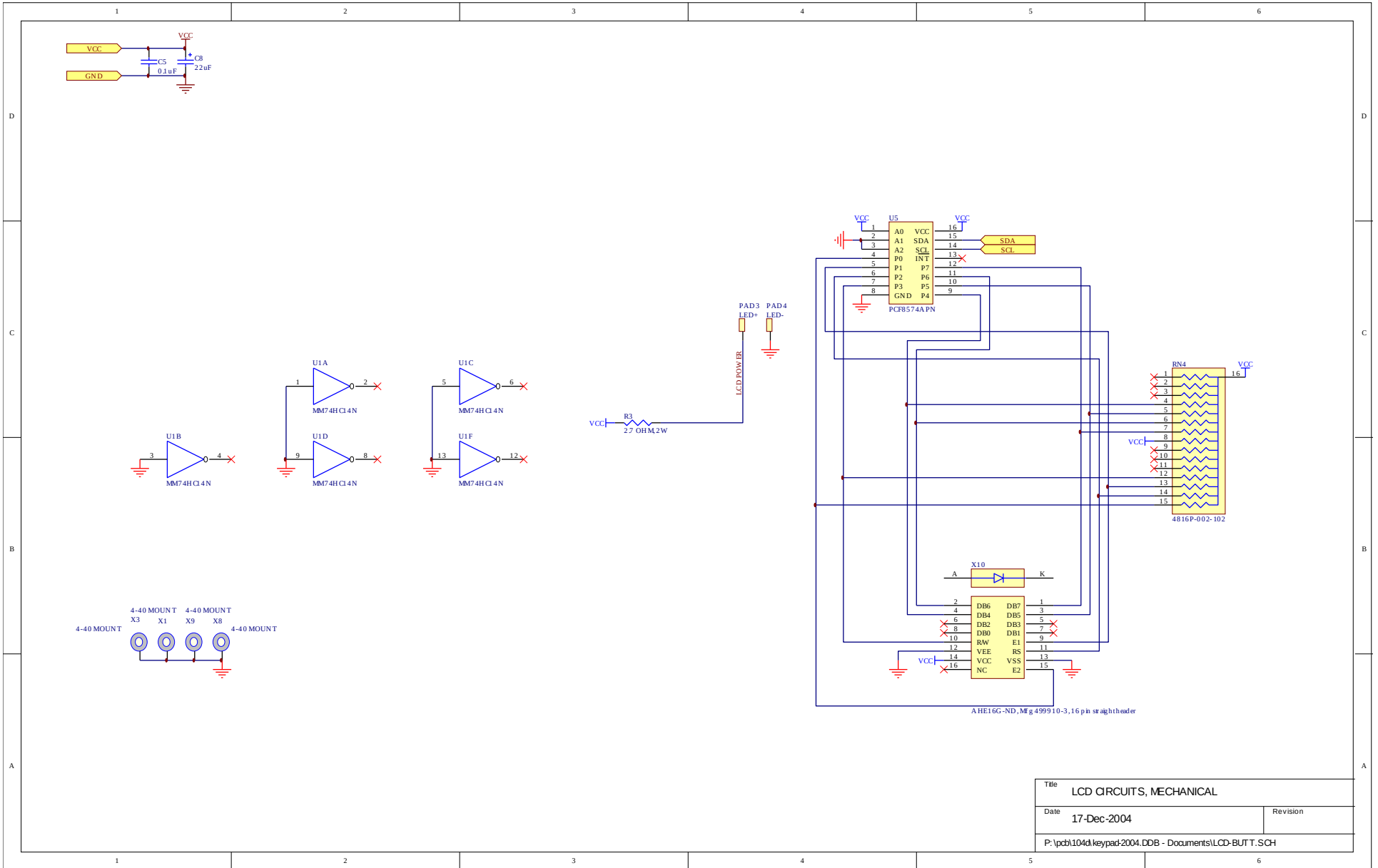

Title		LCD CIRCUITS, MECHANICAL	
Date	17-Dec-2004	Revision	
P:\pcb\104d\keypad\2004.DDB - Documents\LCD-BUTT.SCH			

# MAIN WIRING

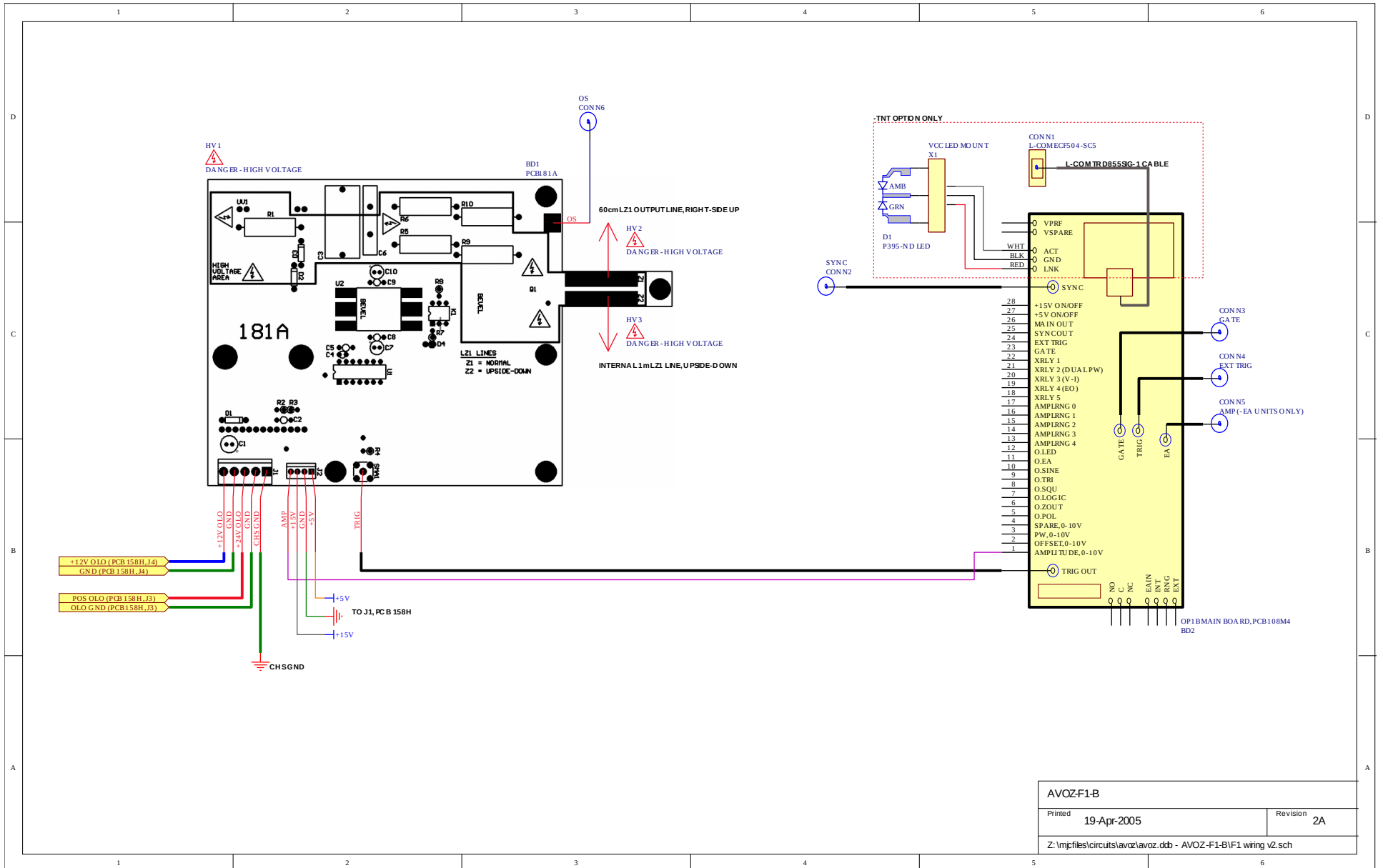

AVOZ-F1-B		
Printed	19-Apr-2005	Revision 2A
Z:\mpjfiles\circuits\lavoz\lavoz.dcb - AVOZ-F1-B\F1 wiring v2.sch		

PERFORMANCE CHECK SHEET