



AVTECH ELECTROSYSTEMS LTD.

NANOSECOND WAVEFORM ELECTRONICS
SINCE 1975

P.O. BOX 265
OGDENSBURG, NY
U.S.A. 13669-0265
TEL: (315) 472-5270
FAX: (613) 226-2802

TEL: 1-800-265-6681
FAX: 1-800-561-1970

e-mail: info@avtechpulse.com
<http://www.avtechpulse.com/>

BOX 5120, LCD MERIVALE
OTTAWA, ONTARIO
CANADA K2C 3H4
TEL: (613) 226-5772
FAX: (613) 226-2802

INSTRUCTIONS

MODEL AVP-2S-C-P-UILB

0 TO 2 VOLTS, 1 MHz

HIGH SPEED PULSE GENERATOR

WITH 40 ps RISE TIME, 135 ps FALL TIME

SERIAL NUMBER: _____

WARRANTY

Avtech Electrosystems Ltd. warrants products of its manufacture to be free from defects in material and workmanship under conditions of normal use. If, within one year after delivery to the original owner, and after prepaid return by the original owner, this Avtech product is found to be defective, Avtech shall at its option repair or replace said defective item. This warranty does not apply to units which have been disassembled, modified or subjected to conditions exceeding the applicable specifications or ratings. This warranty is the extent of the obligation assumed by Avtech with respect to this product and no other warranty or guarantee is either expressed or implied.

TECHNICAL SUPPORT

Phone: 613-226-5772 or 1-800-265-6681

Fax: 613-226-2802 or 1-800-561-1970

E-mail: info@avtechpulse.com

World Wide Web: <http://www.avtechpulse.com>

TABLE OF CONTENTS

WARRANTY.....	2
TECHNICAL SUPPORT.....	2
TABLE OF CONTENTS.....	3
INTRODUCTION.....	4
AVAILABLE OPTIONS.....	5
SPECIAL-ORDER OPTIONS.....	5
SPECIFICATIONS.....	6
ORIGINAL QUOTATION.....	7
INSTALLATION.....	9
VISUAL CHECK.....	9
PLUGGING IN THE INSTRUMENT.....	9
FRONT PANEL CONTROLS.....	11
REAR PANEL CONTROLS.....	13
GENERAL INFORMATION.....	15
BASIC TEST ARRANGEMENT.....	15
BASIC PULSE CONTROL.....	15
EXTERNAL TRIGGER CHARACTERISTICS (-UILB OPTION).....	16
AMPLITUDE INTERACTION.....	16
MINIMIZING WAVEFORM DISTORTIONS.....	17
USE 50Ω TRANSMISSION LINES AND LOADS.....	17
USE LOW-INDUCTANCE LOADS.....	17
PREVENTING DAMAGE.....	18
MECHANICAL INFORMATION.....	19
TOP COVER REMOVAL.....	19
ELECTROMAGNETIC INTERFERENCE.....	19
POWER SUPPLY AND FUSE REPLACEMENT.....	20
MAINTENANCE.....	22
REGULAR MAINTENANCE.....	22
CLEANING.....	22
PERFORMANCE CHECK SHEET.....	23

INTRODUCTION

The AVP-2S-C-P-UILB is a high performance instrument capable of generating up to 2V into 50 Ω loads at repetition rates up to 1 MHz. The rise time is less than 40 ps, and the fall time is less than 135 ps.

Instruments with the "-P" model suffix can generate 0 to +2V, whereas instruments with the "-N" model suffix can generate 0 to -2V.

Instruments with the "-PN" suffix can have two outputs (one positive and one negative). Only one of the two outputs is active at a time.

The output is designed to drive 50 Ω loads. (A 50 Ω load is required for proper operation.) The output is AC-coupled.

This instrument is intended for use in research and development laboratories.

AVAILABLE OPTIONS

The AVP-2S-C-P is available with several options:

-DP Option: provides a burst of two output pulses with a variable time separation of 0 to ± 5 ns,.

-EA Option: the output amplitude can be controlled by an externally generated 0 to +10V analog control voltage.

-ECL Option: the input trigger levels are ECL, rather than TTL.

-EO Option: the output offset can be controlled by an externally generated 0 to +10V analog control voltage.

-EW Option: the output pulse width can be controlled by an externally generated 0 to +10V analog control voltage.

-M Option: a monitor output is provided.

-OS Option: an externally generated DC offset can be added to the output.

-OT Option: an internally generated DC offset, controlled by a front-panel dial, can be added to the output.

SPECIAL-ORDER OPTIONS

-UILB Option: The external trigger input accepts a 0.4V trigger signal, instead of the standard TTL. The input trigger pulse width must be at least 100 ns, and the input trigger rise time must be less than 10 ns. The external trigger input impedance is 50 Ohms.

SPECIFICATIONS

Model:	AVP-2S-C-P-UILB
Amplitude ^{3,4,7} :	0 to 2 Volts. 50Ω load required.
Pulse width ³ :	0.2 - 4.0 ns
PRF: external trigger:	0 Hz to 1 MHz
internal trigger:	100 Hz to 1 MHz
Rise time (20%-80%) ⁷ :	≤ 40 ps
Fall time (80%-20%) ⁷ :	≤ 135 ps
Polarity:	specify -P, -N, or -PN
Dual Polarity Option Style:	Two outputs (+ and -). Only one active at a time.
Double pulse option ⁷ :	Optional. See note 7.
Propagation delay:	≤ 70 ns (Ext trig in to pulse out)
Jitter:	±15 ps (Ext trig in to pulse out)
DC offset or bias insertion:	Option available. Apply required DC offset or bias in the range of ± 50 Volts (250 mA max) to back panel solder terminal. See note 8.
Trigger required:	-UILB option: The external trigger input accepts a 0.4V trigger signal, instead of the standard TTL. The input trigger pulse width must be at least 100 ns, and the input trigger rise time must be less than 10 ns. The external trigger input impedance is 50 Ohms.
Sync delay:	Variable 0 to 500 ns (sync out to pulse out)
Sync output:	+0.5 Volts, 20 ns, will drive 50Ω
Monitor output option ⁹ :	Provides a 20 dB (x10) attenuated coincident replica of main output
Connectors:	
OUT	SMA
TRIG	BNC
SYNC	BNC
MONITOR ⁸	SMA
Power requirement:	120/240 Volts (switchable) 50-60 Hz
Dimensions (H x W x D):	dual-polarity -C units:100 mm x 430 mm x 375 mm (3.9" x 17" x 14.8") single-polarity -C units:100 mm x 215 mm x 375 mm (3.9" x 8.5" x 14.8")
Chassis material:	anodized aluminum, with blue plastic trim
Mounting, Temperature:	Any, +10° to +40° C

1. -C suffix indicates stand-alone lab instrument with internal clock and line powering. -PS suffix indicates line powered instrument requiring external trigger. No suffix indicates miniature module requiring DC power and external trigger. (See page 112 for additional details of the four basic instrument formats).
2. -B suffix indicates IEEE-488.2 GPIB and RS-232 control of amplitude, pulse width, PRF and delay (See page 8).
3. For analog electronic control (0 to +10V) of amplitude, pulse width or DC offset suffix model number with -EA or -EW or -EO. Electronic control units also include standard front-panel controls. -EW not available on -B units.
4. For operation at amplitudes of less than 10% of full-scale, best results will be obtained by setting the amplitude near full-scale and using external attenuators on the output.
5. For 20-500 ns pulse width, suffix model number with -W. Rise time and fall time increase to 150 ps and 200 ps for -W units. -W units have propagation delay of 30 ns.
6. Indicate desired polarity by suffixing model number by -P or -N (i.e. positive or negative) or -P-PN or -N-PN for dual polarity option where the suffix preceding -PN indicates the polarity at the mainframe output port.
8. For double pulse option add suffix -DP. Rise and fall times for units with this option fixed at 300 ps. Units with this option have a maximum output amplitude of 70% of the rated maximum amplitude (except when the relative time delay is set to zero, in which case the addition of the two coincident pulses allows 140% of the rated amplitude to be obtained).
9. For externally applied DC offset option suffix model number with -OS. The Avtech AVX-T bias tee can also be used to obtain DC offset. For internally generated DC offset option (0 to ±5V) add suffix -OT or -EO to model number. (The -OT option is controlled by a front-panel dial, whereas the -EO option can be controlled by a front-panel dial or by an external 0 to +10V voltage). -OT, -EO not available on modules.
10. For monitor option add suffix -M.
11. For ECL trigger option, add suffix -ECL.

ORIGINAL QUOTATION

May 23, 2003

To: Aaron Vandevender
Univ. of Illinois
217-244-1608
vandvndr@uiuc.edu

Aaron,

I am pleased to quote as follows:

Quote number: 11577

Model number: AVP-2S-C-P-UILB

Description: Ultra High Speed Pulse Generator

-UILB option: The external trigger input accepts a 0.4V trigger signal, instead of the standard TTL. The input trigger pulse width must be at least 100 ns, and the input trigger rise time must be less than 10 ns. The external trigger input impedance is 50 Ohms.

Other: as per the standard AVP-2S-C-P. See
<http://www.avtechpulse.com/speed/avp-2s> for details.

Price: \$4698 US each, FOB destination (includes 5% academic discount).

Delivery: 60-75 days after receipt of order.

Please call or email me if I can be of further assistance.

Regards,
Dr. Michael J. Chudobiak
VP, New Product Development

--- Avtech Electrosystems Ltd. ----- since 1975 ---

PO Box 265	ph: 1-800-265-6681 or 613-226-5772	Box 5120 Stn. F
Ogdensburg, NY	fax: 1-800-561-1970 or 613-226-2802	Ottawa, Ontario
USA 13669-0265	email: info@avtechpulse.com	Canada K2C 3H4
	http://www.avtechpulse.com/	

Nanosecond Waveform Generators
for general purpose, R&D and OEM applications

Pulse Generators - Laser Diode Drivers - Pulse Amplifiers
Impulse Generators - Current Pulsers - Delay Generators - Splitters

Function Generators - Monocycle Generators - Frequency Dividers + more!

INSTALLATION

VISUAL CHECK

After unpacking the instrument, examine to ensure that it has not been damaged in shipment. Visually inspect all connectors, knobs, and handles. Confirm that a power cord is with the instrument. If the instrument has been damaged, file a claim immediately with the company that transported the instrument.

PLUGGING IN THE INSTRUMENT

Examine the rear of the instrument. There will be a male power receptacle, a fuse holder and the edge of the power selector card visible. Confirm that the power selector card is in the correct orientation.

For AC line voltages of 110-120V, the power selector card should be installed so that the “120” marking is visible from the rear of the instrument, as shown below:



For AC line voltages of 220-240V, the power selector card should be installed so that the “240” marking is visible from the rear of the instrument, as shown below:



If it is not set for the proper voltage, remove the fuse and then grasp the card with a pair of pliers and remove it. Rotate horizontally through 180 degrees. Reinstall the card and the correct fuse.

In the 120V setting, a 0.5A slow blow fuse is required. In the 240V setting, a 0.25A slow blow fuse is required.

FRONT PANEL CONTROLS

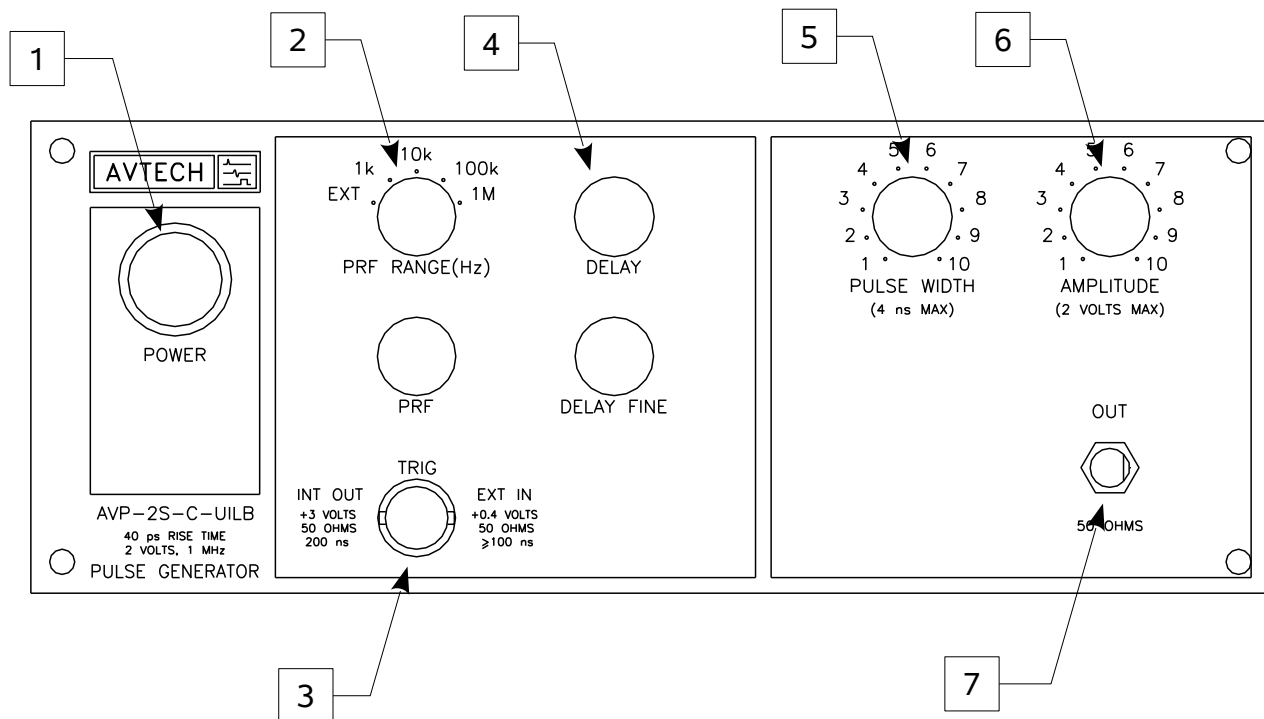

- 1) POWER Switch. This is the main power switch.
- 2) PRF Range Switch. This switch sets the pulse repetition frequency (PRF) range of the internal oscillator. The marked value of each position is the upper limit of the 10:1 range, approximately. The vernier dial directly below the switch varies the PRF within the set range.

If this switched is set to the “EXT” position, the instrument is triggered by a signal applied to the TRIG connector, rather than by the internal oscillator.

- 3) TRIG Connector. When the PRF Range Switch is set to “EXT”, the instrument is triggered by a pulse applied to this connector. This input accepts a 0.4V trigger signal, instead of the standard TTL. The input trigger pulse width must be at least 100 ns, and the input trigger rise time must be less than 10 ns. The external trigger input impedance is 50 Ohms.

When the PRF Range Switch is set to one of the four internal oscillator ranges, this connector is an output, which supplies a 2V, 200 ns wide pulse for each trigger event. This output may be used to trigger oscilloscopes or other equipment.

- 4) Delay Controls. When the PRF Range Switch is set to one of the four internal oscillator ranges, the main output is delayed relative to the TRIG output pulse

(item 3). The delay is variable up to 200 ns, approximately, using the DELAY and DELAY FINE dials.

- 5) Pulse Width Control. This dial controls the pulse width.
- 6) Amplitude Control. This dial controls the pulse amplitude.
- 7) OUT Connector. This SMA connector provides the main output. This output *requires* a 50 Ω load to function properly

3. GND CONNECTOR. (Present on units with -OS option only.) This solder terminal is connected to ground. It may be used to ground the OS input connector.
4. M OUTPUT CONNECTOR. (Present on units with -M option only.) This SMA connector output provides a 20 dB attenuated coincident replica of main output, for monitoring purposes.
5. OFFSET ON/OFF SWITCH & OUTPUT. (Present on units with -EO or -OT options only). This switch enables the offset feature when it is set to “ON”. When it is set to “OFF”, no offset is added to the output. The internally generated offset is available at the “OFFSET OUT” BNC connector, for monitoring purposes. To add an offset to inverted pulses on units with the dual polarity option (-PN), connect this terminal to the DC terminal of the inverting transformer (see the “POLARITY INVERSION” sections in this manual for further details).
6. AMP SWITCH & INPUT. (Present on units with -EA option only.) To control the output amplitude with an external voltage, set the rear-panel switch to the “EXT” position and apply 0 to +10V to the adjacent connector ($R_{IN} \geq 10k\Omega$).
7. PW SWITCH & INPUT. (Present on units with -EW option only.) To control the output pulse width with an external voltage, set the rear-panel switch to the “EXT” position and apply 0 to +10V to the adjacent connector ($R_{IN} \geq 10k\Omega$).

GENERAL INFORMATION

BASIC TEST ARRANGEMENT

The AVP-2S-C-P-UILB should be tested with a sampling oscilloscope with a bandwidth of at least 10 GHz to properly observe the high-speed waveform. A typical test arrangement is shown below:

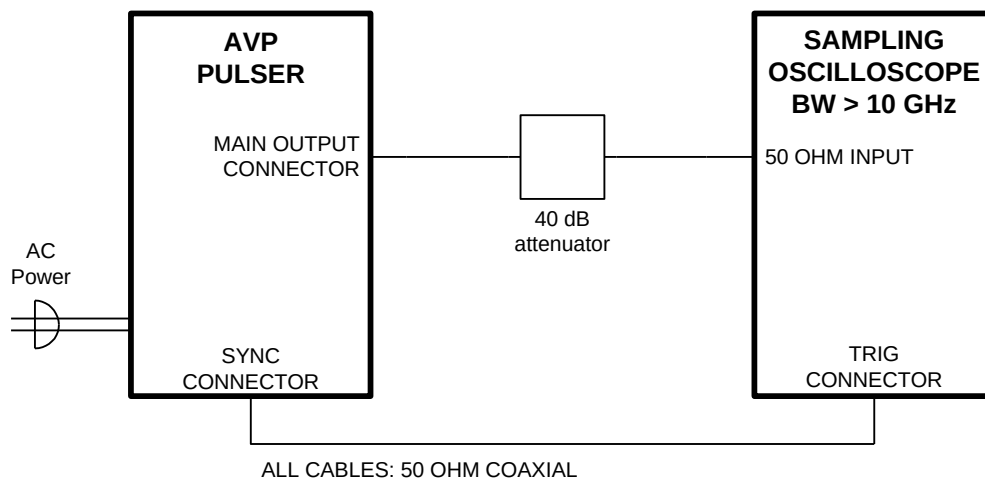

The attenuators are required to prevent damage to the sampling oscilloscope. A 40 dB attenuator with sufficient voltage rating should be used on the main output.

BASIC PULSE CONTROL

This instrument can be triggered by its own internal clock or by an external TTL trigger signal. When triggered internally, two mainframe output channels respond to the trigger: OUT and SYNC.

- OUT. This is the main output. The maximum output voltage is 2V.
- TRIG. The TRIG pulse is a fixed-width TTL-level reference pulse used to trigger oscilloscopes or other measurement systems.

The TRIG output precedes the main output. These pulses are illustrated below:

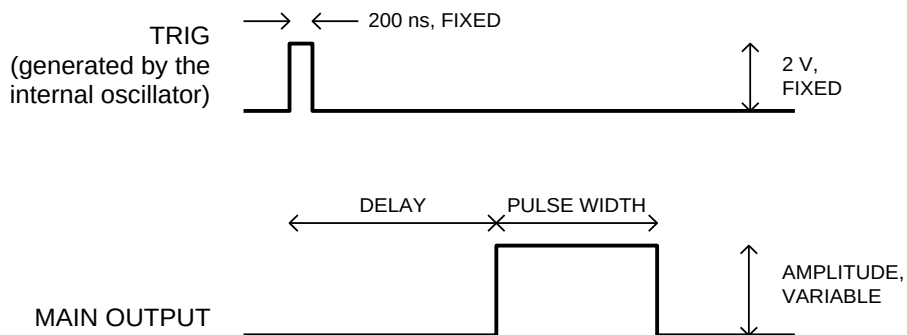

When triggered externally, the TRIG connector acts as an input. The delay controls do not function in this mode. This illustrated below:

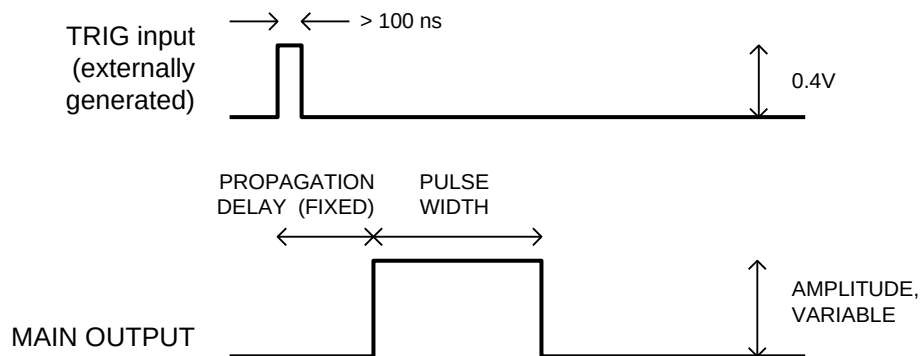

EXTERNAL TRIGGER CHARACTERISTICS (-UILB OPTION)

The external trigger input accepts a (nominal) 0.4V trigger signal, instead of the standard TTL. The input trigger pulse width must be at least 100 ns, and the input trigger rise time must be less than 10 ns. The external trigger input impedance is 50 Ohms.

The safe input range for the external trigger input is 0 to +5V. Voltages outside this range may damage the instrument.

AMPLITUDE INTERACTION

Some properties of the output pulse may change as a function of the amplitude setting. For some demanding applications, it may be desirable to use a combination of external attenuators and the amplitude pot to achieve the desired output amplitude.

MINIMIZING WAVEFORM DISTORTIONS

USE 50Ω TRANSMISSION LINES AND LOADS

Connect the load to the pulse generator with 50Ω transmission lines (e.g. RG-58 or RG-174 cable).

This instrument requires a 50Ω load for proper operation. It will not properly drive a high-impedance load. The output stage will be damaged if it is operated into an open circuit (or any other high impedance). Failures due to improper output loading are not covered by the warranty.

USE LOW-INDUCTANCE LOADS

Lenz's Law predicts that for an inductive voltage spike will be generated when the current through an inductance changes. Specifically, $V_{\text{SPIKE}} = L \times dI_{\text{LOAD}}/dt$, where L is the inductance, I_{LOAD} is the load current change, and t is time. For this reason, it is important to keep any parasitic in the load low. This means keeping wiring short, and using low inductance components. In particular, wire-wound resistors should be avoided.

PREVENTING DAMAGE

The AVP-2S-C-P-UILB may fail if triggered at a PRF greater than 1 MHz.

This unit is designed to operate into a load impedance of 50 Ohms and the output stage will be damaged if it is operated into an open circuit (or any other high impedance). Failures due to improper output loading are not covered by the warranty.

The lifetime of the switching elements in the pulse generator module is proportional to the running time of the instrument. For this reason the prime power to the instrument should be turned off when the instrument is not in use.

The safe input range for the external trigger input is 0 to +5V. Voltages outside this range may damage the instrument.

MECHANICAL INFORMATION

TOP COVER REMOVAL

If necessary, the interior of the instrument may be accessed by removing the four Phillips screws on the top panel. With the four screws removed, the top cover may be slid back (and off).

Always disconnect the power cord before opening the instrument.

There are no user-adjustable internal circuits. For repairs other than fuse replacement, please contact Avtech (info@avtechpulse.com) to arrange for the instrument to be returned to the factory for repair.

⚠ Caution: High voltages are present inside the instrument during normal operation. Do not operate the instrument with the cover removed.

ELECTROMAGNETIC INTERFERENCE

To prevent electromagnetic interference with other equipment, all used outputs should be connected to shielded 50Ω loads using shielded 50Ω coaxial cables. Unused outputs should be terminated with shielded 50Ω BNC terminators or with shielded BNC dust caps, to prevent unintentional electromagnetic radiation. All cords and cables should be less than 3m in length.

POWER SUPPLY AND FUSE REPLACEMENT

This instrument has three main fuses, plus two spares. One, which protects the AC input, is located in the rear-panel power entry module, as described in the “Rear Panel Controls” section of this manual. If the power appears to have failed, check the AC fuse first.

The other two fuses (plus two spares) are located on the internal DC power supply, as shown below:

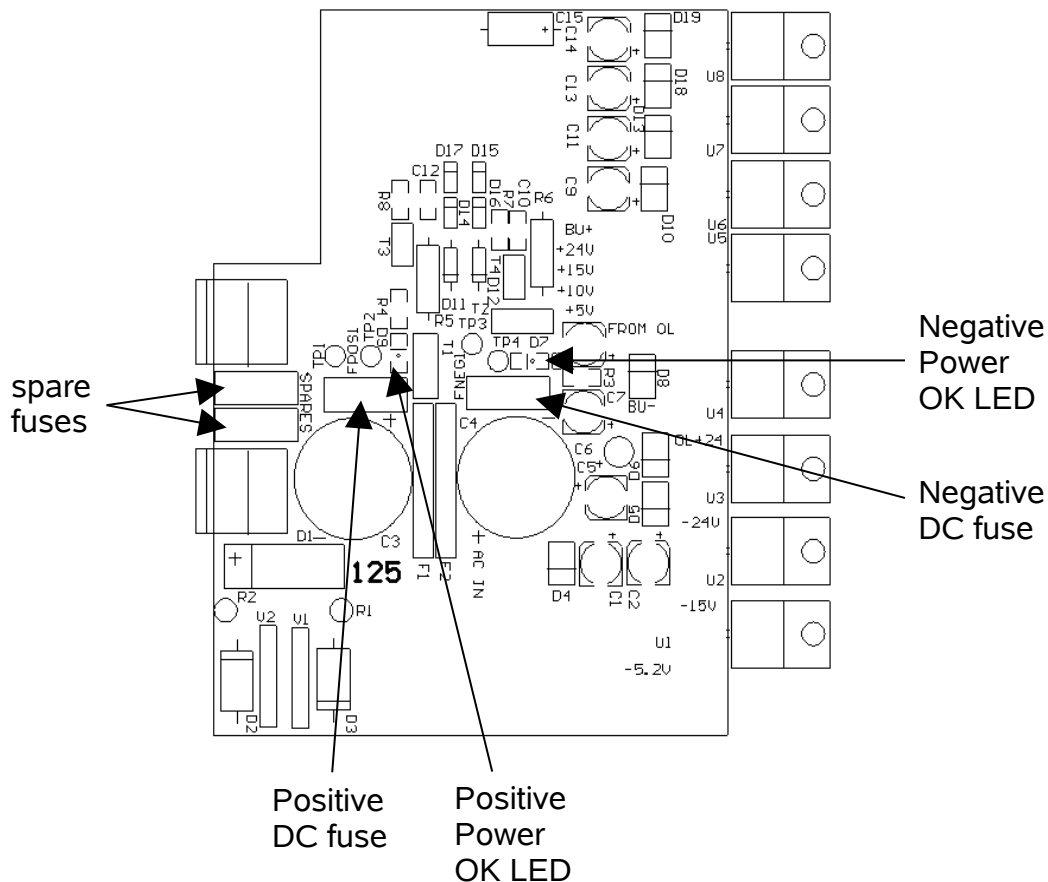

The four fuses on this circuit board are 0.5A slow-blow fuses, Littlefuse part number R452.500. (This fuse can be ordered from Digikey, www.digikey.com. The Digikey part number is F1341CT-ND).

If you suspect that the DC fuses are blown, follow this procedure:

1. Remove the top cover, by removing the four Phillips screws on the top cover and then sliding the cover back and off.
2. Locate the two “Power OK” LEDs on the power supply circuit board, as illustrated above.

3. Turn on the instrument.
4. Observe the “Power OK” LEDs. If the fuses are not blown, the two LEDs will be lit (bright red). If one of the LEDs is not lit, the fuse next to it has blown.
5. Turn off the instrument.
6. If a fuse is blown, use needle-nose pliers to remove the blown fuse from its surface-mount holder.
7. Replace the fuse. (Two spare 0.5 Amp fuses are provided on the circuit board. They may be transferred to the active fuse locations using needle-nose pliers.)

MAINTENANCE

REGULAR MAINTENANCE

This instrument does not require any regular maintenance.

CLEANING

If desired, the interior of the instrument may be cleaned using compressed air to dislodge any accumulated dust. (See the “TOP COVER REMOVAL” section for instructions on accessing the interior.) No other cleaning is recommended.

PERFORMANCE CHECK SHEET