



AVTECH ELECTROSYSTEMS LTD.

NANOSECOND WAVEFORM ELECTRONICS  
SINCE 1975

P.O. BOX 265  
OGDENSBURG, NY  
U.S.A. 13669-0265

TEL: 888-670-8729 (USA & Canada) or +1-613-686-6675 (Intl)  
FAX: 800-561-1970 (USA & Canada) or +1-613-686-6679 (Intl)

info@avtechpulse.com - <http://www.avtechpulse.com/>

BOX 5120, LCD MERIVALE  
OTTAWA, ONTARIO  
CANADA K2C 3H5

## INSTRUCTIONS

MODEL AVP-AV-1-B

10 VOLT, 1 MHz

HIGH PERFORMANCE PULSE GENERATOR

WITH IEEE 488.2 AND RS-232 CONTROL

SERIAL NUMBER: \_\_\_\_\_

### WARRANTY

Avtech Electrosystems Ltd. warrants products of its manufacture to be free from defects in material and workmanship under conditions of normal use. If, within one year after delivery to the original owner, and after prepaid return by the original owner, this Avtech product is found to be defective, Avtech shall at its option repair or replace said defective item. This warranty does not apply to units which have been disassembled, modified or subjected to conditions exceeding the applicable specifications or ratings. This warranty is the extent of the obligation assumed by Avtech with respect to this product and no other warranty or guarantee is either expressed or implied.

### TECHNICAL SUPPORT

Phone: 888-670-8729 (USA & Canada) or +1-613-686-6675 (International)

Fax: 800-561-1970 (USA & Canada) or +1-613-686-6679 (International)

E-mail: [info@avtechpulse.com](mailto:info@avtechpulse.com)

World Wide Web: <http://www.avtechpulse.com>

## TABLE OF CONTENTS

<b>WARRANTY.....</b>	<b>2</b>
<b>TECHNICAL SUPPORT.....</b>	<b>2</b>
<b>TABLE OF CONTENTS.....</b>	<b>3</b>
<b>INTRODUCTION.....</b>	<b>6</b>
<b>AVAILABLE OPTIONS.....</b>	<b>7</b>
<b>SPECIFICATIONS.....</b>	<b>8</b>
<b>REGULATORY NOTES.....</b>	<b>9</b>
FCC PART 18.....	9
EC DECLARATION OF CONFORMITY.....	9
DIRECTIVE 2011/65/EU (RoHS).....	10
DIRECTIVE 2002/96/EC (WEEE).....	10
FIRMWARE LICENSING.....	11
<b>INSTALLATION.....</b>	<b>12</b>
VISUAL CHECK.....	12
POWER RATINGS.....	12
CONNECTION TO THE POWER SUPPLY.....	12
PROTECTION FROM ELECTRIC SHOCK.....	13
ENVIRONMENTAL CONDITIONS.....	14
LABVIEW DRIVERS.....	14
<b>FUSES.....</b>	<b>15</b>
AC FUSE REPLACEMENT.....	15
DC FUSE REPLACEMENT.....	16
FUSE RATINGS.....	16
<b>FRONT PANEL CONTROLS.....</b>	<b>17</b>
<b>REAR PANEL CONTROLS.....</b>	<b>19</b>
<b>GENERAL INFORMATION.....</b>	<b>22</b>
BASIC PULSE CONTROL.....	22
TRIGGER MODES.....	23
GATING MODES.....	24
OPERATION AT LOW AMPLITUDES.....	24
<b>DUAL-OUTPUT OPTIONS.....</b>	<b>25</b>
<b>OTHER OPTIONAL FEATURES.....</b>	<b>26</b>
DC OFFSET, "-OT" OPTION.....	26

DC OFFSET, "-EO" OPTION.....	26
MONITOR OUTPUT, "-M" OPTION.....	26
ELECTRONIC AMPLITUDE CONTROL, "-EA" OPTION.....	26
<b><i>PROTECTING YOUR INSTRUMENT</i></b> .....	<b>27</b>
TURN OFF INSTRUMENT WHEN NOT IN USE.....	27
DO NOT EXCEED 1 MHz.....	27
USE A 50Ω LOAD.....	27
<b><i>OPERATIONAL CHECK</i></b> .....	<b>28</b>
<b><i>PROGRAMMING YOUR PULSE GENERATOR</i></b> .....	<b>31</b>
KEY PROGRAMMING COMMANDS.....	31
PROGRAMMING COMMANDS FOR -2CH UNITS.....	32
ALL PROGRAMMING COMMANDS.....	32
<b><i>MECHANICAL INFORMATION</i></b> .....	<b>34</b>
TOP COVER REMOVAL.....	34
RACK MOUNTING.....	34
ELECTROMAGNETIC INTERFERENCE.....	34
<b><i>MAINTENANCE</i></b> .....	<b>35</b>
REGULAR MAINTENANCE.....	35
CLEANING.....	35
TRIGGER DAMAGE.....	35
<b><i>WIRING DIAGRAMS</i></b> .....	<b>36</b>
WIRING OF AC POWER.....	36
WIRING OF HIGH VOLTAGE POWER SUPPLY.....	37
PCB 158Q - LOW VOLTAGE POWER SUPPLY, 1/3.....	38
PCB 158Q - LOW VOLTAGE POWER SUPPLY, 2/3.....	39
PCB 158Q - LOW VOLTAGE POWER SUPPLY, 3/3.....	40
PCB 235B - HIGH VOLTAGE DC POWER SUPPLY.....	41
PCB 231A - INTERNAL OFFSET GENERATOR.....	42
PCB 216E - PW/PRF TWEAK.....	43
PCB 104F - KEYPAD / DISPLAY BOARD, 1/3.....	44
PCB 104F - KEYPAD / DISPLAY BOARD, 2/3.....	45
PCB 104F - KEYPAD / DISPLAY BOARD, 3/3.....	46
MAIN WIRING.....	47
<b><i>PERFORMANCE CHECKSHEET</i></b> .....	<b>48</b>

Last modified February 29, 2024.  
Copyright © 2024 Avtech Electrosystems Ltd, All Rights Reserved.

## INTRODUCTION

The AVP-AV-1-B is a high performance, GPIB and RS232-equipped instrument capable of generating 10V into 50 $\Omega$  loads at repetition rates up to 1 MHz. The output pulse width is variable from 0.4 to 4 ns. The rise time is 100 ps or less, and the fall time is 300 ps or less.

Instruments with the "-P" model suffix can generate up to +10V, whereas instruments with the "-N" model suffix can generate up to -10V. Instruments with the "-PN" suffix can generate both polarities.

The AVP-AV-1-B is a highly flexible instrument. Aside from the internal trigger source, it can also be triggered or gated by external TTL-level signals. A front-panel pushbutton or a computer command can also be used to trigger the instrument.

The AVP-AV-1-B features front panel keyboard and adjust knob control of the output pulse parameters along with a four line by 40-character backlit LCD display of the output amplitude, pulse width, pulse repetition frequency, and delay. The instrument includes memory to store up to four complete instrument setups. The operator may use the front panel or the computer interface to store a complete "snapshot" of all key instrument settings, and recall this setup at a later time.

## AVAILABLE OPTIONS

The AVP-AV-1-B is available with several options:

-OT Option: this option adds an internally-generated 0 to  $\pm 5V$  DC offset to the main output.

-EO Option: the DC offset can be controlled by an externally generated 0 to +10V analog control voltage.

-EA Option: the amplitude can be controlled by an externally generated 0 to +10V analog control voltage.

-M Option: a monitor output is provided.

-R5 Option: A rack mounting kit is available. The "-R5" rack mount kit may be installed after first removing the one Phillips screw on the side panel adjacent to the front handle.

-VXI Option: Adds a rear-panel Ethernet connector, allowing the instrument to be remotely controlled using the VXI-11.3, ssh (secure shell), telnet, and http (web) protocols. In particular, the VXI-11.3 features allows software like LabView to control an instrument using standard VISA communications drivers and network cabling, instead of using old-style GPIB cabling. (This eliminates the need for a GPIB controller card and its proprietary drivers.)

-2CHPP, -2CHPN, -2CHNN Options: To specify two positive outputs, add the suffix -2CHPP to the model number. To specify two negative outputs, add the suffix -2CHNN. To specify one positive and one negative output, add the suffix -2CHPN.

## SPECIFICATIONS

Model:	AVP-AV-1-B <sup>2</sup>
Maximum amplitude <sup>3,4,8</sup> : (50Ω load)	10 Volts
Pulse width (FWHM) <sup>3</sup> :	0.4 - 4 ns
PRF: external trigger mode:	0 Hz to 1 MHz
internal trigger mode:	100 Hz to 1 MHz
Rise time (20%-80%) <sup>7,8</sup> :	≤ 100 ps
Fall time (80%-20%) <sup>7,8</sup> :	≤ 300 ps
Polarity:	specify -P, -N, or -PN
Dual-Polarity Option Style: (not available on modules)	one output, with switchable polarity
Required load impedance:	50 Ohms <sup>14</sup>
GPIO and RS-232 control <sup>2</sup> :	Standard on -B units. Not available on -C units or modules.
LabView Drivers:	-B units only: check <a href="http://www.avtechpulse.com/labview">http://www.avtechpulse.com/labview</a> for availability and downloads
Ethernet port, for remote control using VXI-11.3, ssh, telnet, & web:	Optional on -B units <sup>9</sup> . Recommended as a modern alternative to GPIO / RS-232. See <a href="http://www.avtechpulse.com/options/vxi">http://www.avtechpulse.com/options/vxi</a> for details.
Settings resolution:	The resolution of the timing parameters (pulse width, delay, period) varies, but is always better than 0.15% of ( set value  + 20 ns). The amplitude resolution is < 0.1% of the maximum amplitude.
Settings accuracy:	Typically ± 3% (± 2 ns or ± 2% of max. amplitude) after 10 minute warmup, for pulse widths > 1 ns and PRF ≤ 10 kHz. At lower pulse widths and higher PRFs, the amplitude tends to roll off relative to the set value. For high-accuracy applications requiring traceable calibration, verify the output with a calibrated oscilloscope.
Two channel option:	Optional <sup>7</sup> . Available on -B & -C models.
Double pulse option:	Optional <sup>8</sup> . Available on -B & -C models. 0 to ±5 ns pulse separation (other ranges available).
Propagation delay:	≤ 140 ns <sup>16</sup> (Ext trig in to pulse out)
Jitter, Ext trig in to pulse out:	-C units and Modules: ±15 ps    -B units: ± 35ps ± 0.015% of sync delay
Trigger modes:	Internal trigger, external trigger (TTL level pulse, > 10 ns, 1 kΩ input impedance), front-panel "Single Pulse" pushbutton, or single pulse trigger via computer command
Variable delay:	Sync to main out: 0 to 1.0 seconds, for all trigger modes (including external trigger).
Sync output:	+3 Volts, > 50 ns, will drive 50 Ohm loads
DC offset or bias insertion:	Optional <sup>10</sup> . Apply required DC offset or bias in the range of ± 50V (250 mA max) to back panel solder terminal.
Monitor output option <sup>11</sup> :	Provides a 20 dB (x10) attenuated coincident replica of main output
Connectors: OUT, MONITOR: TRIG, SYNC, GATE:	SMA BNC
Optional accessory kit: (attenuators and terminators)	Add the suffix "-AK1" to the model number to include the recommended accessory kit. Consists of three SMA, 18 GHz, 2 Watt attenuators (10, 20 & 30 dB) for use on the output, and two 50 Ohm, 1 GHz, 1 Watt feed-through terminators (one SMA, one BNC) for use on external trigger inputs.
Optional accessory kit: (coaxial cables and adapters)	Add the suffix "-AK8" to the model number to include the recommended accessory kit. Consists of one 12-inch SMA-M/SMA-M PE-SR405FL coaxial cable, one 12-inch SMA-M/SMA-M RG-316 coaxial cable, one 36-inch SMA-M/SMA-M RG-316 coaxial cable, one 24-inch SMA-M/BNC-M RG-316 coaxial cable, one 36-inch BNC-M/BNC-M RG58C/U coaxial cable, one SMA-F to BNC-M adapter, one SMA-M to BNC-F adapter, one SMA-F to SMA-F adapter, and one SMA-F to solder cup adapter
Temperature range:	+5°C to +40°C
Other: Power requirements: Dimensions: Chassis material:	100 - 240 Volts, 50 - 60 Hz 100 × 430 × 375 mm (3.9" × 17" × 14.8") anodized aluminum, with blue plastic trim

- 1) -C suffix indicates stand-alone lab instrument with internal clock and line powering. No suffix indicates miniature module requiring DC power and external trigger. (See <http://www.avtechpulse.com/formats> for details of the four basic instrument formats).
- 2) -B suffix indicates IEEE-488.2 GPIO and RS-232 control of amplitude, pulse width, PRF and delay (See <http://www.avtechpulse.com/gpio>).
- 3) For analog electronic control (0 to +10V) of amplitude, pulse width or DC offset suffix model number with -EA or -EW or -EO. Electronic control units also include standard front-panel controls. -EW not available on -B units.
- 4) For operation at amplitudes of less than 20% of full-scale, best results will be obtained by setting the amplitude near full-scale and using external attenuators on the output.
- 5) For 20-500 ns pulse width, suffix model number with -W500. Rise times increase to 150 ps for -W500 units.
- 6) Indicate desired polarity by suffixing model number by -P or -N (i.e. positive or negative) or -P-PN or -N-PN for dual-polarity option where the suffix preceding -PN indicates the polarity at the mainframe output port.
- 7) For the two channel option, add the suffix -2CHPP for two positive outputs, the suffix -2CHNN for two negative outputs, or the suffix -2CHPN for the one positive output and one negative output.
- 8) For the double pulse option add the suffix -DPP for a unipolar output, and add the suffix -DPN for a bipolar output. These options cause the maximum amplitude to be reduced by 30%, and increase the rise and fall times by 50 ps.
- 9) Add the suffix -VXI to the model number to specify the Ethernet port.
- 10) For externally applied DC offset option suffix model number with -OS. The Avtech AVX-T bias tee can also be used to obtain DC offset. For internally generated DC offset option (0 to ±5V) add suffix -OT or -EO to model number. (The -OT option is controlled by a front-panel dial, whereas the -EO option can be controlled by a front-panel dial or by an external 0 to +10V voltage). -OT, -EO not available on modules.
- 11) For monitor option add suffix -M.
- 12) At maximum pulse width. The maximum amplitude may fall for narrower pulse widths, with reduction of < 25% at the minimum specified pulse width.
- 13) Typically < 100 ps at minimum pulse width. Increases at wider pulse widths.
- 14) A 50 Ohm load is required. Other loads may damage the instrument. Consult Avtech ([info@avtechpulse.com](mailto:info@avtechpulse.com)) if you need to drive other load impedances.
- 15) For 0.4 - 4 ns pulse width, suffix model number with -W4.
- 16) Add 200 ns to propagation delay specification for units with the -DPP or -DPN double-pulse options.



## REGULATORY NOTES

### FCC PART 18

This device complies with part 18 of the FCC rules for non-consumer industrial, scientific and medical (ISM) equipment.

This instrument is enclosed in a rugged metal chassis and uses a filtered power entry module (where applicable). The main output signal is provided on a shielded connector that is intended to be used with shielded coaxial cabling and a shielded load. Under these conditions, the interference potential of this instrument is low.

If interference is observed, check that appropriate well-shielded cabling is used on the output connectors. Contact Avtech ([info@avtechpulse.com](mailto:info@avtechpulse.com)) for advice if you are unsure of the most appropriate cabling. Also, check that your load is adequately shielded. It may be necessary to enclose the load in a metal enclosure.

If any of the connectors on the instrument are unused, they should be covered with shielded metal "dust caps" to reduce the interference potential.

This instrument does not normally require regular maintenance to minimize interference potential. However, if loose hardware or connectors are noted, they should be tightened. Contact Avtech ([info@avtechpulse.com](mailto:info@avtechpulse.com)) if you require assistance.

### EC DECLARATION OF CONFORMITY



We                      Avtech Electrosystems Ltd.  
                             P.O. Box 5120, LCD Merivale  
                             Ottawa, Ontario  
                             Canada K2C 3H5

declare that this pulse generator meets the intent of Directive 2004/108/EG for Electromagnetic Compatibility. Compliance pertains to the following specifications as listed in the official Journal of the European Communities:

EN 50081-1 Emission

EN 50082-1 Immunity

and that this pulse generator meets the intent of the Low Voltage Directive 2006/95/EC. Compliance pertains to the following specifications as listed in the official Journal of the European Communities:

EN 61010-1:2001 Safety requirements for electrical equipment for measurement, control, and laboratory use

DIRECTIVE 2011/65/EU (RoHS)

We Avtech Electrosystems Ltd.  
P.O. Box 5120, LCD Merivale  
Ottawa, Ontario  
Canada K2C 3H5

declare that, to the best of our knowledge, all electrical and electronic equipment (EEE) sold by the company are in compliance with Directive 2011/65/EU of the European Parliament and of the Council of 8 June 2011 on the restriction of the use of certain hazardous substances in electrical and electronic equipment (also known as “RoHS Recast”). In addition, this declaration of conformity is issued under the sole responsibility of Avtech Electrosystems Ltd. Specifically, products manufactured do not contain the substances listed in the table below in concentrations greater than the listed maximum value.

<i>Material/Substance</i>	<i>Threshold level</i>
Lead (Pb)	< 1000 ppm (0.1% by mass)
Mercury (Hg)	< 1000 ppm (0.1% by mass)
Hexavalent Chromium (Cr6+)	< 1000 ppm (0.1% by mass)
Polybrominated Biphenyls (PBB)	< 1000 ppm (0.1% by mass)
Polybrominated Diphenyl ethers (PBDE)	< 1000 ppm (0.1% by mass)
Cadmium (Cd)	< 100 ppm (0.01% by mass)

DIRECTIVE 2002/96/EC (WEEE)

European customers who have purchased this equipment directly from Avtech will have completed a “WEEE Responsibility Agreement” form, accepting responsibility for WEEE compliance (as mandated in Directive 2002/96/EC of the European Union and local laws) on behalf of the customer, as provided for under Article 9 of Directive 2002/96/EC.

Customers who have purchased Avtech equipment through local representatives should consult with the representative to determine who has responsibility for WEEE

compliance. Normally, such responsibilities will lie with the representative, unless other arrangements (under Article 9) have been made.

Requirements for WEEE compliance may include registration of products with local governments, reporting of recycling activities to local governments, and financing of recycling activities.

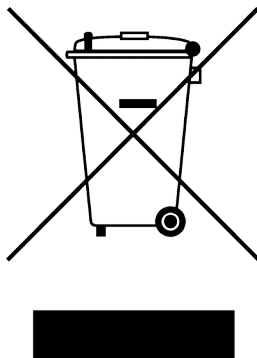

### FIRMWARE LICENSING

Instruments with firmware versions 5.00 or higher use open-source software internally. Some of this software requires that the source code be made available to the user as a condition of its licensing. This source code is available upon request (contact [info@avtechpulse.com](mailto:info@avtechpulse.com)).

Earlier firmware versions do not contain any open source software.

## INSTALLATION

### VISUAL CHECK

After unpacking the instrument, examine to ensure that it has not been damaged in shipment. Visually inspect all connectors, knobs, liquid crystal displays (LCDs), and the handles. Confirm that a power cord, a GPIB cable, and two instrumentation manuals (this manual and the “Programming Manual for -B Instruments”) are with the instrument. If the instrument has been damaged, file a claim immediately with the company that transported the instrument.

### POWER RATINGS

This instrument is intended to operate from 100 - 240 V, 50 - 60 Hz.

The maximum power consumption is 57 Watts. Please see the “FUSES” section for information about the appropriate AC and DC fuses.

This instrument is an “Installation Category II” instrument, intended for operation from a normal single-phase supply.

### CONNECTION TO THE POWER SUPPLY

An IEC-320 three-pronged recessed male socket is provided on the back panel for AC power connection to the instrument. One end of the detachable power cord that is supplied with the instrument plugs into this socket. The other end of the detachable power cord plugs into the local mains supply. Use only the cable supplied with the instrument. The mains supply must be earthed, and the cord used to connect the instrument to the mains supply must provide an earth connection. (The supplied cord does this.)

 Warning: Failure to use a grounded outlet may result in injury or death due to electric shock. This product uses a power cord with a ground connection. It must be connected to a properly grounded outlet. The instrument chassis is connected to the ground wire in the power cord.

The table below describes the power cord that is normally supplied with this instrument, depending on the destination region:

Destination Region	Description	Option	Manufacturer	Part Number
United Kingdom, Hong Kong, Singapore, Malaysia	BS 1363, 230V, 50 Hz	-AC00	Qualtek	370001-E01
Australia, New Zealand	AS 3112:2000, 230-240V, 50 Hz	-AC01	Qualtek	374003-A01
Continental Europe, Korea, Indonesia, Russia	European CEE 7/7 "Schuko" 230V, 50 Hz	-AC02	Qualtek	364002-D01
North America, Taiwan	NEMA 5-15, 120V, 60 Hz	-AC03	Qualtek	312007-01
Switzerland	SEV 1011, 230V, 50 Hz	-AC06	Qualtek	378001-E01
South Africa, India	SABS 164-1, 220-250V, 50 Hz	-AC17	Volex	2131H 10 C3
Japan	JIS 8303, 100V, 50-60 Hz	-AC18	Qualtek	397002-01
Israel	SI 32, 220V, 50 Hz	-AC19	Qualtek	398001-01
China	GB 1002-1, 220V, 50 Hz	-AC22	Volex	2137H 10 C3

## PROTECTION FROM ELECTRIC SHOCK

 Operators of this instrument must be protected from electric shock at all times. The owner must ensure that operators are prevented access and/or are insulated from every connection point. In some cases, connections must be exposed to potential human contact. Operators must be trained to protect themselves from the risk of electric shock. This instrument is intended for use by qualified personnel who recognize shock hazards and are familiar with safety precautions required to avoid possibly injury. In particular, operators should:

1. Keep exposed high-voltage wiring to an absolute minimum.
2. Wherever possible, use shielded connectors and cabling.
3. Connect and disconnect loads and cables only when the instrument is turned off.
4. Keep in mind that all cables, connectors, oscilloscope probes, and loads must have an appropriate voltage rating.
5. Do not attempt any repairs on the instrument, beyond the fuse replacement procedures described in this manual. Contact Avtech technical support (see page 2 for contact information) if the instrument requires servicing. Service is to be performed solely by qualified service personnel.

## ENVIRONMENTAL CONDITIONS

This instrument is intended for use under the following conditions:

1. indoor use;
2. altitude up to 2 000 m;
3. temperature 5 °C to 40 °C;
4. maximum relative humidity 80 % for temperatures up to 31 °C decreasing linearly to 50 % relative humidity at 40 °C;
5. Mains supply voltage fluctuations up to  $\pm 10$  % of the nominal voltage;
6. no pollution or only dry, non-conductive pollution.

## LABVIEW DRIVERS

A LabVIEW driver for this instrument is available for download on the Avtech web site, at <http://www.avtechpulse.com/labview>. A copy is also available in National Instruments' Instrument Driver Library at <http://www.natinst.com/>.

## FUSES

This instrument contains four fuses. All are accessible from the rear-panel. Two protect the AC prime power input, and two protect the internal DC power supplies. The locations of the fuses on the rear panel are shown in the figure below:

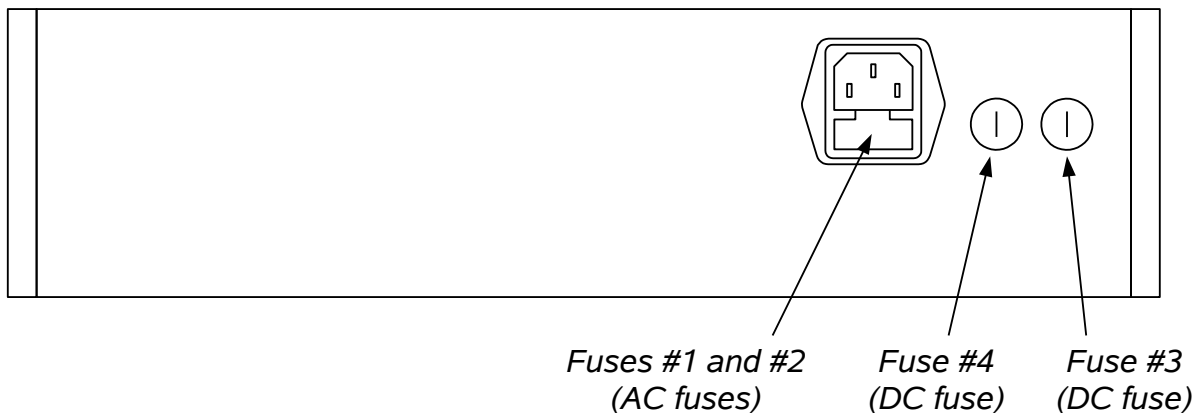

### AC FUSE REPLACEMENT

To physically access the AC fuses, the power cord must be detached from the rear panel of the instrument. The fuse drawer may then be extracted using a small flat-head screwdriver, as shown below:

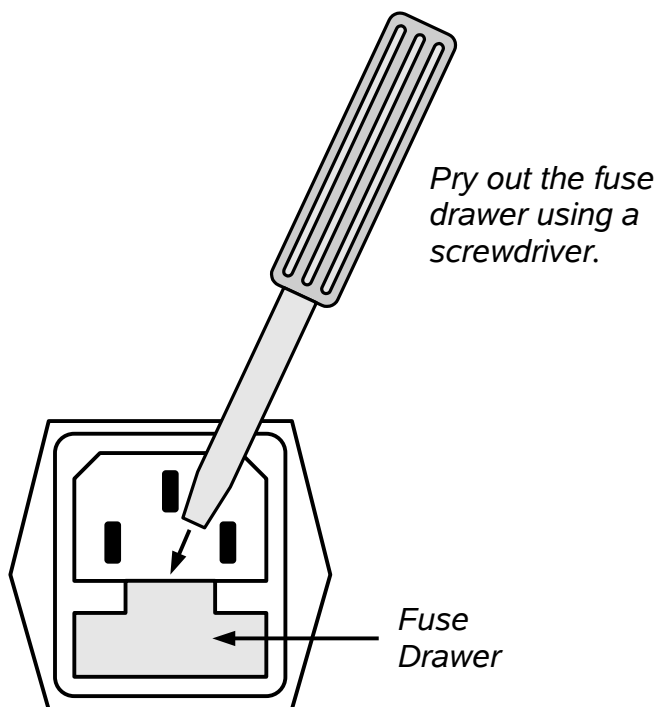

## DC FUSE REPLACEMENT

The DC fuses may be replaced by inserting the tip of a flat-head screwdriver into the fuse holder slot, and rotating the slot counter-clockwise. The fuse and its carrier will then pop out.

## FUSE RATINGS

The following table lists the required fuses:

Fuses	Nominal Mains Voltage	Rating	Case Size	Recommended Replacement Part	
				Littelfuse Part Number	Digi-Key Stock Number
#1, #2 (AC)	100-240V	0.5A, 250V, Time-Delay	5×20 mm	0218.500HXP	F2416-ND
#3 (DC)	N/A	1.6A, 250V, Time-Delay	5×20 mm	021801.6HXP	F2424-ND
#4 (DC)	N/A	0.5A, 250V, Time-Delay	5×20 mm	0218.500HXP	F2416-ND

The recommended fuse manufacturer is Littelfuse (<http://www.littelfuse.com>).

Replacement fuses may be easily obtained from Digi-Key (<http://www.digikey.com>) and other distributors.



## FRONT PANEL CONTROLS

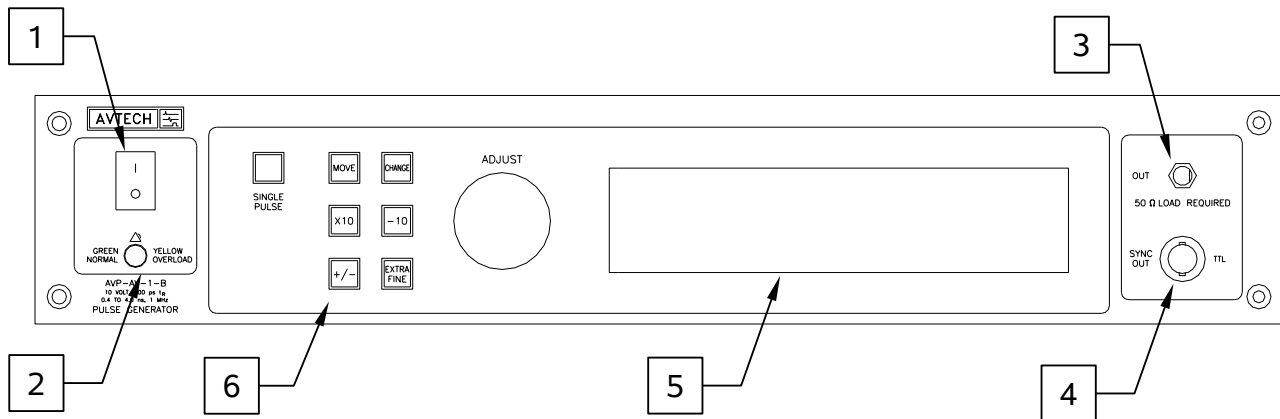

1. **POWER Switch.** This is the main power switch. When turning the instrument on, there is normally a delay of 10 seconds before anything is shown on the main display, as the internal operating system boots up.

If the main menu does not appear after 30 seconds, turn off the instrument and leave it off for at least 60 seconds before applying power again.

2. **OVERLOAD Indicator.** When the instrument is powered, this indicator is normally green, indicating normal operation. If this indicator is yellow, an internal automatic overload protection circuit has been tripped. If the unit is overloaded (by operating at an exceedingly high duty cycle or by operating into a very low impedance), the protective circuit will disable the output of the instrument and turn the indicator light yellow. The light will stay yellow (i.e. output disabled) for about 5 seconds after which the instrument will attempt to re-enable the output (i.e. light green) for about 1 second. If the overload condition persists, the output will be disabled again (i.e. light yellow) for another 5 seconds. If the overload condition has been removed, the instrument will resume normal operation.

This overload indicator may flash yellow briefly at start-up. This is not a cause for concern.

3. **OUT CONNECTOR.** This SMA connector provides the main output signal, into load impedances of 50Ω.
4. **SYNC OUT.** This connector supplies a SYNC output that can be used to trigger other equipment, particularly oscilloscopes. This signal leads (or lags) the main output by a duration set by the "DELAY" controls and has an approximate amplitude of +3 Volts to  $R_L > 1k\Omega$  with a pulse width of approximately 100 ns.
5. **LIQUID CRYSTAL DISPLAY (LCD).** This LCD is used in conjunction with the keypad to change the instrument settings. Normally, the main menu is displayed, which lists the key adjustable parameters and their current values. The "Programming Manual for -B Instruments" describes the menus and submenus in

detail.

6. KEYPAD.

Control Name	Function
MOVE	This moves the arrow pointer on the display.
CHANGE	This is used to enter the submenu, or to select the operating mode, pointed to by the arrow pointer.
×10	If one of the adjustable numeric parameters is displayed, this increases the setting by a factor of ten.
÷10	If one of the adjustable numeric parameters is displayed, this decreases the setting by a factor of ten.
+/-	If one of the adjustable numeric parameters is displayed, and this parameter can be both positive or negative, this changes the sign of the parameter.
EXTRA FINE	This changes the step size of the ADJUST knob. In the extra-fine mode, the step size is twenty times finer than in the normal mode. This button switches between the two step sizes.
ADJUST	This large knob adjusts the value of any displayed numeric adjustable values, such as frequency, pulse width, etc. The adjust step size is set by the "EXTRA FINE" button.  When the main menu is displayed, this knob can be used to move the arrow pointer.

## REAR PANEL CONTROLS

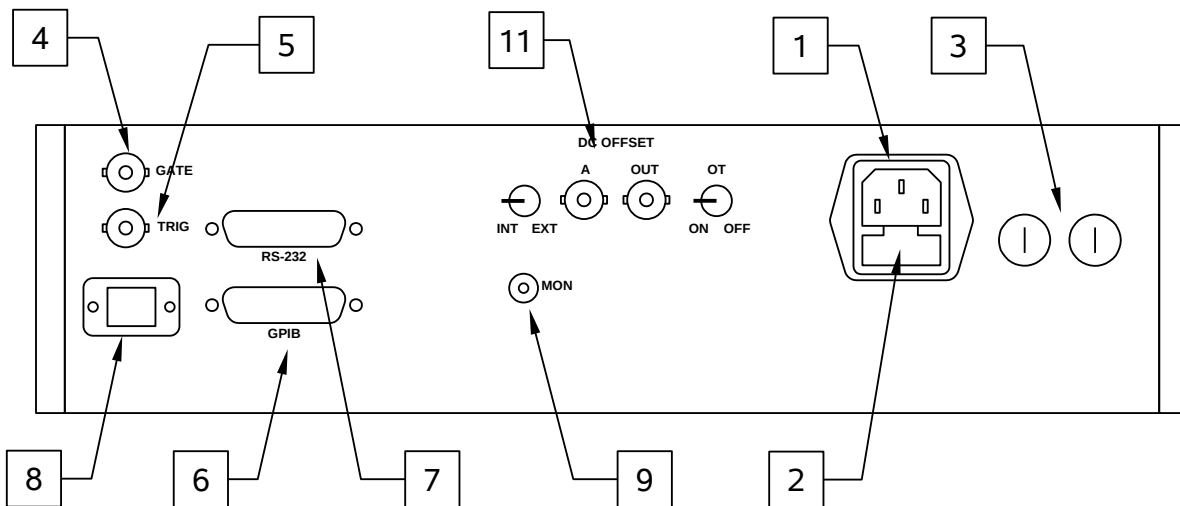

*Note: some connectors may be in different positions than shown above, depending on the exact combination of options ordered.*

1. **AC POWER INPUT.** An IEC-320 C14 three-pronged recessed male socket is provided on the back panel for AC power connection to the instrument. One end of the detachable power cord that is supplied with the instrument plugs into this socket.
2. **AC FUSE DRAWER.** The two fuses that protect the AC input are located in this drawer. Please see the “FUSES” section of this manual for more information.
3. **DC FUSES.** These two fuses protect the internal DC power supplies. Please see the “FUSES” sections of this manual for more information.
4. **GATE.** This TTL-level (0 and +5V) logic input can be used to gate the triggering of the instrument. This input can be either active high or active low, depending on the front panel settings or programming commands. (The instrument triggers normally when this input is unconnected). When set to active high mode, this input is pulled-down to ground by a 1 k $\Omega$  resistor. When set to active low mode, this input is pulled-up to +5V by a 1 k $\Omega$  resistor.
5. **TRIG.** This TTL-level (0 and +5V) logic input can be used to trigger the instrument, if the instrument is set to triggering externally. The instrument triggers on the rising edge of this input. The input impedance of this input is 1 k $\Omega$ . (Depending on the length of cable attached to this input, and the source driving it, it may be desirable to add a coaxial 50 Ohm terminator to this input to provide a proper transmission line termination. The Pasternack ([www.pasternack.com](http://www.pasternack.com)) PE6008-50 BNC feed-thru 50 Ohm terminator is suggested for this purpose.)

6. GPIB Connector. A standard GPIB cable can be attached to this connector to allow the instrument to be computer-controlled. See the “Programming Manual for -B Instruments” for more details on GPIB control.
7. RS-232 Connector. A standard serial cable with a 25-pin male connector can be attached to this connector to allow the instrument to be computer-controlled. A user name (“admin”) and a password (“default”, as shipped from the factory) are required when logging into a serial terminal session. The internal controller attempts to auto-sense the parity setting. It may be necessary to send a few return characters before attempting a login in order to provide enough data to allow this auto-sensing to work. (A standard Linux “agetty” process is used to implement serial control internally.) See the “Programming Manual for -B Instruments” for more details on RS-232 control.
8. Network Connector. (Optional feature. Present on -VXI units only.) This Ethernet connector allows the instrument to be remotely controlled using the VXI-11.3, ssh (secure shell), telnet, and http (web) protocols. See the “Programming Manual for -B Instruments” for more details.
9. M Connectors. (Optional feature. Present on "-M" units only.) The monitor output provides an attenuated replica (20 dB down) of the voltage on the main output. The monitor output is designed to operate into a 50 Ohm load. -PN units will have two monitor outputs (MP and MN, one for each polarity).
10. Depending on the selected options, these offset-related controls may also be present:

OS Connector. (Optional feature. Present on units with the -OS option only). This connector allows an externally generated DC offset to be added to the output. The desired DC offset is applied to this connector, which is connected to the output centre conductor through a high-quality RF inductor. Do not exceed  $\pm 50\text{V}$ , 250 mA.

DC OFFSET OT ON/OFF Switch. (Optional feature. Present on units with the -OT and -EO options only). If this switch is set to “ON”, the instrument generates a DC offset internally. The magnitude of this offset is controlled by the front panel settings (if the DC OFFSET INT/EXT switch is in the INT position) or by the control voltage applied to the “A” connector (if the DC OFFSET INT/EXT switch is in the EXT position.) If this switch is set to “OFF”, a user-generated DC offset may be connected to the “DC OFFSET OUT” BNC connector. Do not exceed  $\pm 50\text{V}$ , 250 mA.

DC OFFSET OUT Connector. (Optional feature. Present on units with the -OT and -EO options only). This connector allows an externally generated DC offset to be added to the output. The desired DC offset is applied to this connector, which is connected to the output centre conductor through a high-quality RF inductor. Do not exceed  $\pm 50\text{V}$ , 250 mA. This offset is only applied if the DC OFFSET INT/EXT switch is in the EXT position.

DC OFFSET A Connector. (Optional feature. Present on units with the -EO option only). If the DC OFFSET INT/EXT switch is in the EXT position, a 0 to +10V control voltage applied to this input will vary the output DC offset over the range of -5V to +5V,

approximately.

DC OFFSET INT/EXT Switch. (Optional feature. Present on units with the -EO option only). Determines whether the output DC offset is controlled by the front panel settings (INT), or by a 0 to +10V control voltage applied to the “A” connector (EXT).

## GENERAL INFORMATION

### BASIC PULSE CONTROL

This instrument can be triggered by its own internal clock or by an external TTL trigger signal. In either case, two output channels respond to the trigger: OUT and SYNC.

- OUT. This is the main output.
- SYNC. The SYNC pulse is a fixed-width TTL-level reference pulse used to trigger oscilloscopes or other measurement systems. When the delay is set to a positive value the SYNC pulse precedes the OUT pulse. When the delay is set to a negative value the SYNC pulse follows the OUT pulse.

These pulses are illustrated below, assuming internal triggering and a positive delay:

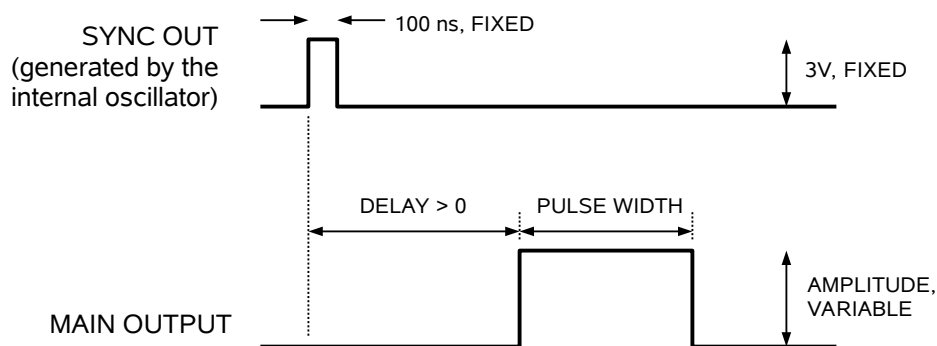

*Figure A*

If the delay is negative, the order of the SYNC and OUT pulses is reversed:

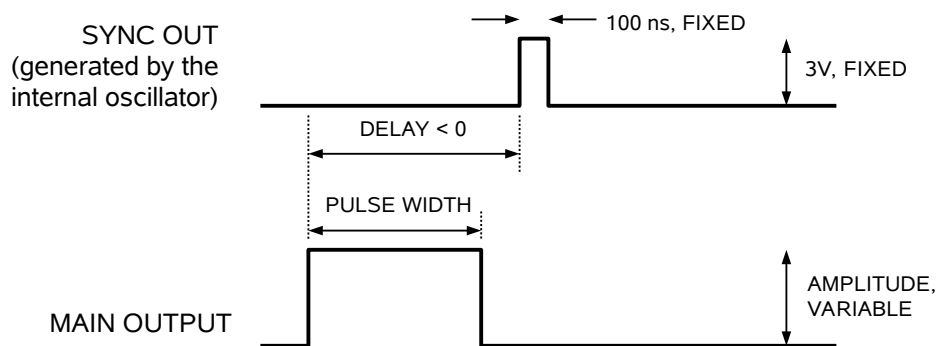

*Figure B*

The next figure illustrates the relationship between the signals when an external TTL-level trigger is used:

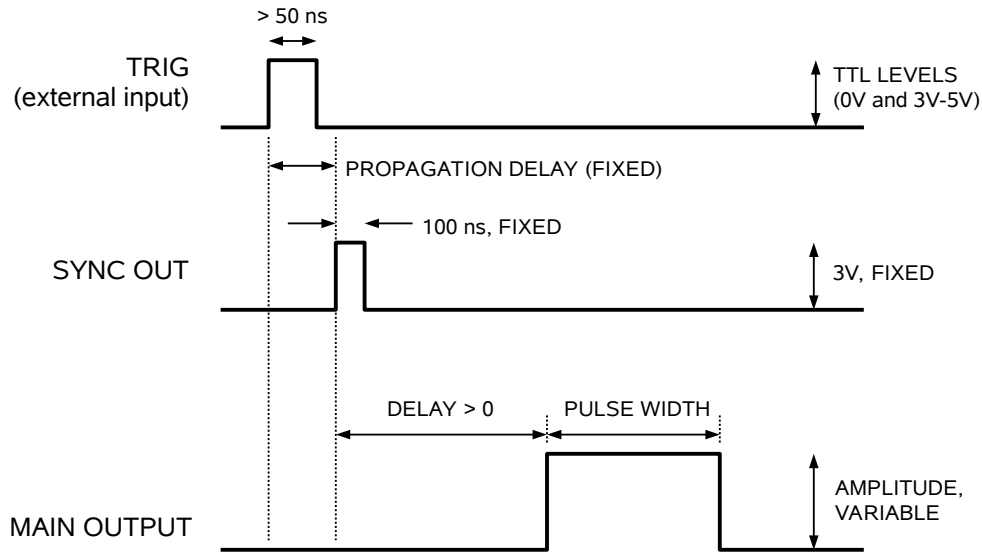

Figure C

As before, if the delay is negative, the order of the SYNC and OUT pulses is reversed.

In general, the delay, pulse width, and frequency (when in the internal mode), of the OUT pulse can be varied with front panel controls or via the GPIB or RS-232 computer interfaces.

### TRIGGER MODES

This instrument has four trigger modes:

- Internal Trigger: the instrument controls the trigger frequency, and generates the clock internally.
- External Trigger: the instrument is triggered by an external TTL-level clock on the back-panel TRIG connector.
- Manual Trigger: the instrument is triggered by the front-panel "SINGLE PULSE" pushbutton.
- Hold Trigger: the instrument is set to not trigger at all.

These modes can be selected using the front panel trigger menu, or by using the appropriate programming commands. (See the "Programming Manual for -B Instruments" for more details.)

## GATING MODES

Triggering can be suppressed by a TTL-level signal on the rear-panel GATE connector. The instrument can be set to stop triggering when this input high or low, using the front-panel gate menu or the appropriate programming commands. When gated, the output will complete the full pulse width if the output is high, and then stop triggering. Pulses are not truncated.

## OPERATION AT LOW AMPLITUDES

This instrument will generate the best waveforms when operated near maximum amplitude. If amplitudes less than ~ 20% of the full-scale value are desired, better results will be obtained if the pulse generator is operated at a higher amplitude, and an attenuator is connected to the output.

Avtech recommends the BW-SxxW2+ series of 18 GHz coaxial attenuators from Mini-Circuits, <http://www.minicircuits.com/>. (The “xx” in the part number is replaced with the numeric attenuation value in dB).



## DUAL-OUTPUT OPTIONS

The AVP-AV-1-B is optionally available with two outputs, each with independent pulse width and amplitude controls. The two channels share a common trigger source, and have a variable delay separation of 0 to  $\pm 50$  ns. To specify two positive outputs, add the suffix -2CHPP to the model number. To specify two negative outputs, add the suffix -2CHNN. To specify one positive and one negative output, add the suffix -2CHPN.

The timing diagrams in the previous section apply to the Channel 1 output. The second channel (added by the -2CH options) is positioned relative to the Channel 1 output, as shown below:

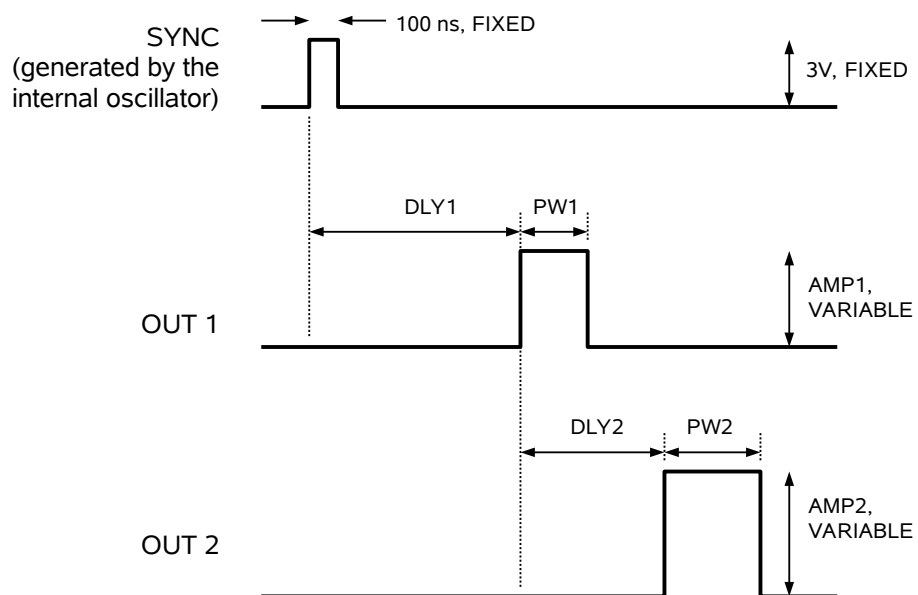

## OTHER OPTIONAL FEATURES

### DC OFFSET, "-OT" OPTION

This option adds an internally-generated 0 to  $\pm 5\text{V}$  DC offset to the main output. The offset level is set by the front-panel controls, or by computer commands. The rear-panel OS switch must be set to "ON" to activate the internally-generated offset feature.

### DC OFFSET, "-EO" OPTION

This option allows adds a DC offset to the main output, which is controlled by an externally generated 0 to +10V analog control voltage applied to a rear-panel connector. An input of 0 Volts corresponds to an output offset of -5V, and an input of 10 Volts corresponds to an output offset of +5V, approximately.

### MONITOR OUTPUT, "-M" OPTION

The monitor output provides an attenuated replica (20 dB down) of the voltage on the main output. The monitor output is designed to operate into a 50 Ohm load.

### ELECTRONIC AMPLITUDE CONTROL, "-EA" OPTION

The output amplitude can be set to track the voltage on this input. Zero Volts in corresponds to zero amplitude output, and +10V in corresponds to maximum amplitude out. This mode is activated by selecting "Ext Control" on the front-panel amplitude menu, or with the "source:voltage external" command.

## PROTECTING YOUR INSTRUMENT

### TURN OFF INSTRUMENT WHEN NOT IN USE

The lifetime of the switching elements in the pulse generator module is proportional to the running time of the instrument. For this reason the prime power to the instrument should be turned off when the instrument is not in use. In the case of failure, the switching elements are easily replaced following the procedure described in a following section.

### DO NOT EXCEED 1 MHz

The output stage may be damaged if triggered by an external signal at a pulse repetition frequency greater than 1 MHz.

### USE A 50Ω LOAD

The output stage may be damaged if the output is not terminated into a 50Ω load.

## OPERATIONAL CHECK

This section describes a sequence to confirm the basic operation of the instrument. It should be performed after receiving the instrument. It is a useful learning exercise as well.

Before proceeding with this procedure, finish reading this instruction manual thoroughly. Then read the “Local Control” section of the “Programming Manual for -B Instruments” thoroughly. The “Local Control” section describes the front panel controls used in this operational check - in particular, the MOVE, CHANGE, and ADJUST controls.

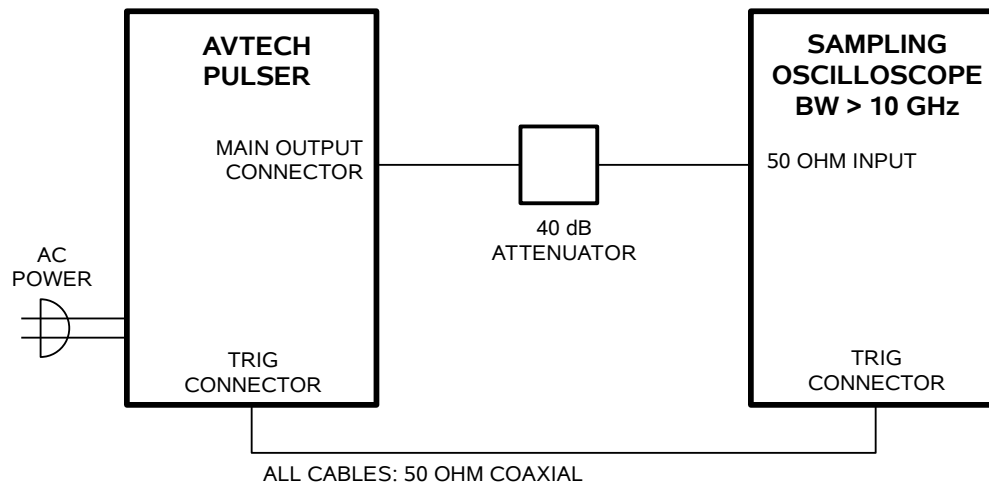

### *BASIC TEST ARRANGEMENT*

1. Connect the pulse generator to a sampling oscilloscope as shown above. Note that:
  - a) The use of 40 dB attenuator at the sampling scope vertical input channel will insure a peak input signal to the sampling scope of less than 1 Volt. Factory tests are conducted using two Mini-Circuits model BW-S20W2+ attenuators in series.
  - b) The TRIG output channel provides TTL level signals (approximately 0 and +3V). To avoid overdriving the TRIG input channel of some scopes, a 20 dB attenuator should be placed at the input to the scope trigger channel.
  - c) The bandwidth capability of components and instruments used to display the pulse generator output signal (attenuators, cables, connectors, etc.) should exceed 10 GHz.
  - d) Set the oscilloscope to trigger externally with the vertical setting at 100 mV/div and the horizontal setting at 5 ns/div.

2. Turn on the AVP-AV-1-B. The main menu will appear on the LCD.
3. To set the AVP-AV-1-B to trigger from the internal clock at a PRF of 10 kHz:
  - a) The arrow pointer should be pointing at the frequency menu item. If it is not, press the MOVE button until it is.
  - b) Press the CHANGE button. The frequency submenu will appear. Rotate the ADJUST knob until the frequency is set at 10 kHz.
  - c) The arrow pointer should be pointing at the “Internal” choice. If it is not, press MOVE until it is.
  - d) Press CHANGE to return to the main menu.
4. To set the delay to 100 ns:
  - a) Press the MOVE button until the arrow pointer is pointing at the delay menu item.
  - b) Press the CHANGE button. The delay submenu will appear. Rotate the ADJUST knob until the delay is set at 100 ns.
  - c) The arrow pointer should be pointing at the “Normal” choice. If it is not, press MOVE until it is.
  - d) Press CHANGE to return to the main menu.
5. To set the pulse width to 3 ns:
  - a) Press the MOVE button until the arrow pointer is pointing at the pulse width menu item.
  - b) Press the CHANGE button. The pulse width submenu will appear. Rotate the ADJUST knob until the pulse width is set at 3 ns.
  - c) The arrow pointer should be pointing at the “Normal” choice. If it is not, press MOVE until it is.
  - d) Press CHANGE to return to the main menu.
6. At this point, nothing should appear on the oscilloscope.
7. To enable the output:

- a) Press the MOVE button until the arrow pointer is pointing at the output menu item.
  - b) Press the CHANGE button. The output submenu will appear.
  - c) Press MOVE until the arrow pointer is pointing at the "ON" choice.
  - d) Press CHANGE to return to the main menu.
8. To change the output amplitude:
- a) Press the MOVE button until the arrow pointer is pointing at the amplitude menu item.
  - b) Press the CHANGE button. The amplitude submenu will appear. Rotate the ADJUST knob until the amplitude is set at +10V (or -10V for "-N" models).
  - c) Observe the oscilloscope. You should see 3 ns wide, 10V pulses. If you do not, you may need to adjust the delay setting to a value more compatible with your sampling oscilloscope. Repeat step 4 if required. You may also need to adjust the sampling scope controls.
  - d) Rotate the ADJUST knob. The amplitude as seen on the oscilloscope should vary. Return it to 10V.
  - e) ("-PN" units only) Press the +/- button on the front panel. The amplitude as seen on the oscilloscope should flip polarity, to -10V.
  - f) Press CHANGE to return to the main menu.

This completes the operational check.

## PROGRAMMING YOUR PULSE GENERATOR

### KEY PROGRAMMING COMMANDS

The “Programming Manual for -B Instruments” describes in detail how to connect the pulse generator to your computer, and the programming commands themselves. A large number of commands are available; however, normally you will only need a few of these. Here is a basic sample sequence of commands that might be sent to the instrument after power-up:

*rst	(resets the instrument)
trigger:source internal	(selects internal triggering)
frequency 1000 Hz	(sets the frequency to 1000 Hz)
pulse:width 2 ns	(sets the pulse width to 2 ns)
pulse:delay 20 ns	(sets the delay to 20 ns)
volt:ampl 10	(sets the amplitude to +10 V)
	("-N" units should use "volt:ampl -10)
output on	(turns on the output)

For triggering a single event, this sequence would be more appropriate:

*rst	(resets the instrument)
trigger:source hold	(turns off all triggering)
pulse:width 2 ns	(sets the pulse width to 2 ns)
output on	(turns on the output)
volt:ampl 10	(sets the amplitude to +10 V)
	("-N" units should use "volt:ampl -10)
trigger:source immediate	(generates a single non-repetitive trigger event)
trigger:source hold	(turns off all triggering)
output off	(turns off the output)

To set the instrument to trigger from an external TTL signal applied to the rear-panel TRlg connector, use:

*rst	(resets the instrument)
trigger:source external	(selects external triggering)
pulse:width 2 ns	(sets the pulse width to 2 ns)
pulse:delay 1 us	(sets the delay to 1 us)
volt:ampl 10	(sets the amplitude to +10 V)
	("-N" units should use "volt:ampl -10)
output on	(turns on the output)

## PROGRAMMING COMMANDS FOR -2CH UNITS

Units with the -2CHPP, -2CHPN, and -2CHNN options will have two sets of programmable pulse widths, delays, and amplitudes. On these units, a channel identifier should be appended to these commands, like so:

```

pulse:width1 1 ns      (sets the CH1 pulse width to 1 ns)
pulse:width2 2 ns      (sets the CH2 pulse width to 2 ns)
pulse:delay1 1 us      (sets the CH1 delay to 1 us)
pulse:delay2 10 ns     (sets the CH2 delay to 10 ns)
volt:ampl1 5           (sets the amplitude to +5 V)
volt:ampl2 10          (sets the amplitude to +10 V)

```

If no channel identifier is used, “1” is assumed.

These commands will satisfy 90% of your programming needs.

## ALL PROGRAMMING COMMANDS

For more advanced programmers, a complete list of the available commands is given below. These commands are described in detail in the “Programming Manual for -B Instruments”. (Note: this manual also includes some commands that are not implemented in this instrument. They can be ignored.)

<u>Keyword</u>	<u>Parameter</u>	<u>Notes</u>
OUTPut:		
:[STATe]	<boolean value>	
:PROTection		
:TRIPped?		[query only]
[SOURce]:		
:FREQuency		
[:CW   FIXed]	<numeric value>	
[SOURce]:		
:PULSe		
:PERiod	<numeric value>	
:WIDTh	<numeric value>	
:DCYClE	<numeric value>	
:HOLD	WIDTh   DCYClE	
:DELay	<numeric value>	
:GATE		
:TYPE	ASYNc   SYNc	
:LEVel	High   Low	
[SOURce]:		
:VOLTage		
[:LEVel]		
[:IMMediate]		
[:AMPLitude]	<numeric value>   EXTeRnal	
:PROTection		
:TRIPped?		[query only]
STATUS:		



:OPERation		
:[EVENT]?		[query only, always returns "0"]
:CONDition?		[query only, always returns "0"]
:ENABle	<numeric value>	[implemented but not useful]
:QUESTionable		
:[EVENT]?		[query only, always returns "0"]
:CONDition?		[query only, always returns "0"]
:ENABle	<numeric value>	[implemented but not useful]
SYSTem:		
:COMMunicate		
:GPIB		
:ADDRes	<numeric value>	
:SERial		
:CONTrol		
:RTS	ON   IBFull   RFR	
:[RECeive]		
:BAUD	1200   2400   4800   9600   19200   38400   57600   115200	
:ERRor		
:[NEXT]?		[query only]
:COUNT?		[query only]
:VERSion?		[query only]
TRIGger:		
:SOURce	INTernal   EXTernal   MANual   HOLD   IMMEDIATE	[no query form]
*CLS		
*ESE	<numeric value>	
*ESR?		[query only]
*IDN?		[query only]
*OPC		
*SAV	0   1   2   3	[no query form]
*RCL	0   1   2   3	[no query form]
*RST		[no query form]
*SRE	<numeric value>	
*STB?		[query only]
*TST?		[query only]
*WAI		[no query form]

## MECHANICAL INFORMATION

### TOP COVER REMOVAL

If necessary, the interior of the instrument may be accessed by removing the four Phillips screws on the top panel. With the four screws removed, the top cover may be slid back (and off).

 Always disconnect the power cord and allow the instrument to sit unpowered for 10 minutes before opening the instrument. This will allow any internal stored charge to discharge.

There are no user-adjustable internal circuits. For repairs other than fuse replacement, please contact Avtech (info@avtechpulse.com) to arrange for the instrument to be returned to the factory for repair. Service is to be performed solely by qualified service personnel.

 Caution: High voltages are present inside the instrument during normal operation. Do not operate the instrument with the cover removed.

### RACK MOUNTING

A rack mounting kit is available. The -R5 rack mount kit may be installed after first removing the one Phillips screw on the side panel adjacent to the front handle.

### ELECTROMAGNETIC INTERFERENCE

To prevent electromagnetic interference with other equipment, all used outputs should be connected to shielded loads using shielded coaxial cables. Unused outputs should be terminated with shielded coaxial terminators or with shielded coaxial dust caps, to prevent unintentional electromagnetic radiation. All cords and cables should be less than 3m in length.

## MAINTENANCE

### REGULAR MAINTENANCE

This instrument does not require any regular maintenance.

On occasion, one or more of the four rear-panel fuses may require replacement. All fuses can be accessed from the rear panel. See the “FUSES” section for details.

### CLEANING

If desired, the interior of the instrument may be cleaned using compressed air to dislodge any accumulated dust. (See the “TOP COVER REMOVAL” section for instructions on accessing the interior.) No other cleaning is recommended.

### TRIGGER DAMAGE

The rear-panel TRIG input, used in the external trigger mode, is protected by a diode clamping circuit. However, the protection circuit is not foolproof, and it is possible for a grossly excessive signal to damage the trigger circuitry on the main timing control board (the 4×10 inch board on the right side of the instrument).

The IC that is most likely to fail under these conditions is installed in a socket. It is a standard TTL IC in a 16-pin plastic DIP package, model 74F151 or equivalent.

If you suspect that this IC has been damaged, turn off the power and replace this IC. It may be replaced by a 74F151, 74LS151, 74ALS151, or 74HCT151.

# WIRING DIAGRAMS

## WIRING OF AC POWER

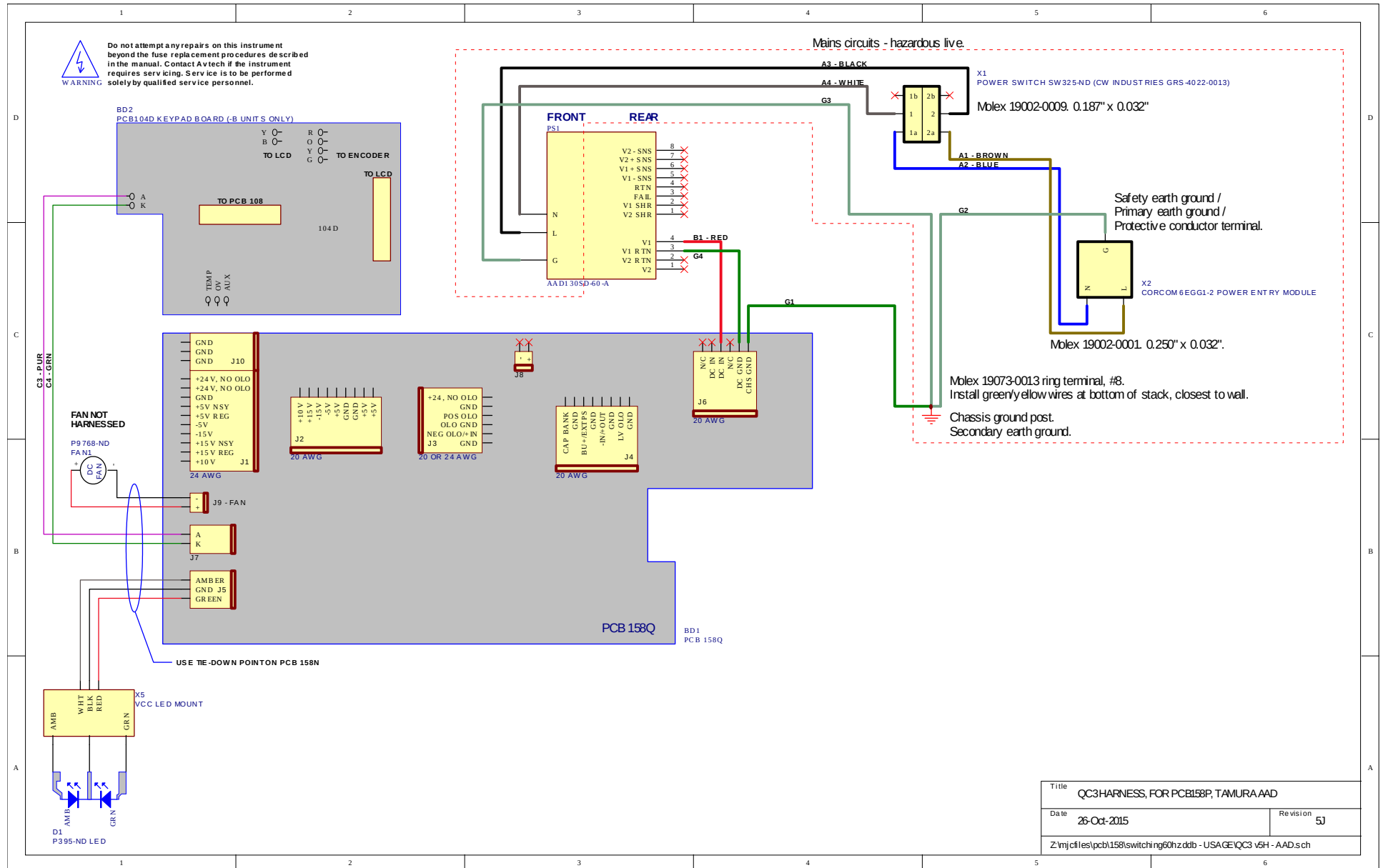

Title		QC3 HARNESS, FOR PCB158P, TAMURA AAD	
Date	26-Oct-2015	Revision	5J
Z:\njcf\es\pcb158\switching60hzddb - USA GE\QC3 v5H - AAD.sch			

# WIRING OF HIGH VOLTAGE POWER SUPPLY

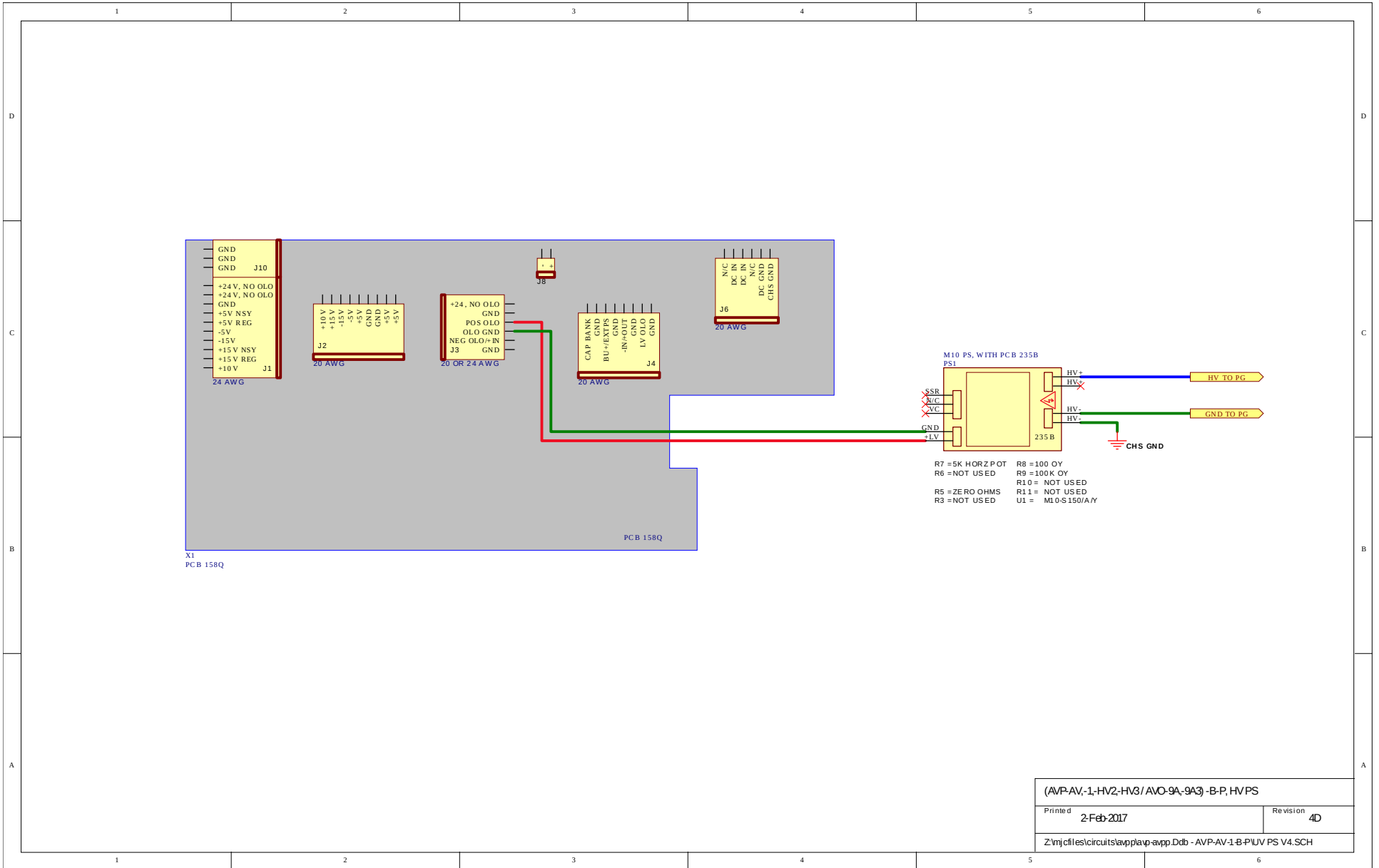

(AVP-AV,-1,-HV2,-HV3 / AVO-9A,-9A3) -B-P, HVPS	
Printed 2-Feb-2017	Revision 4D
Z:\njcf\es\circuits\avp\avp-avpp.ddb - AVP-AV-1-B-PIUV PS V4.SCH	

# PCB 158Q - LOW VOLTAGE POWER SUPPLY, 1/3

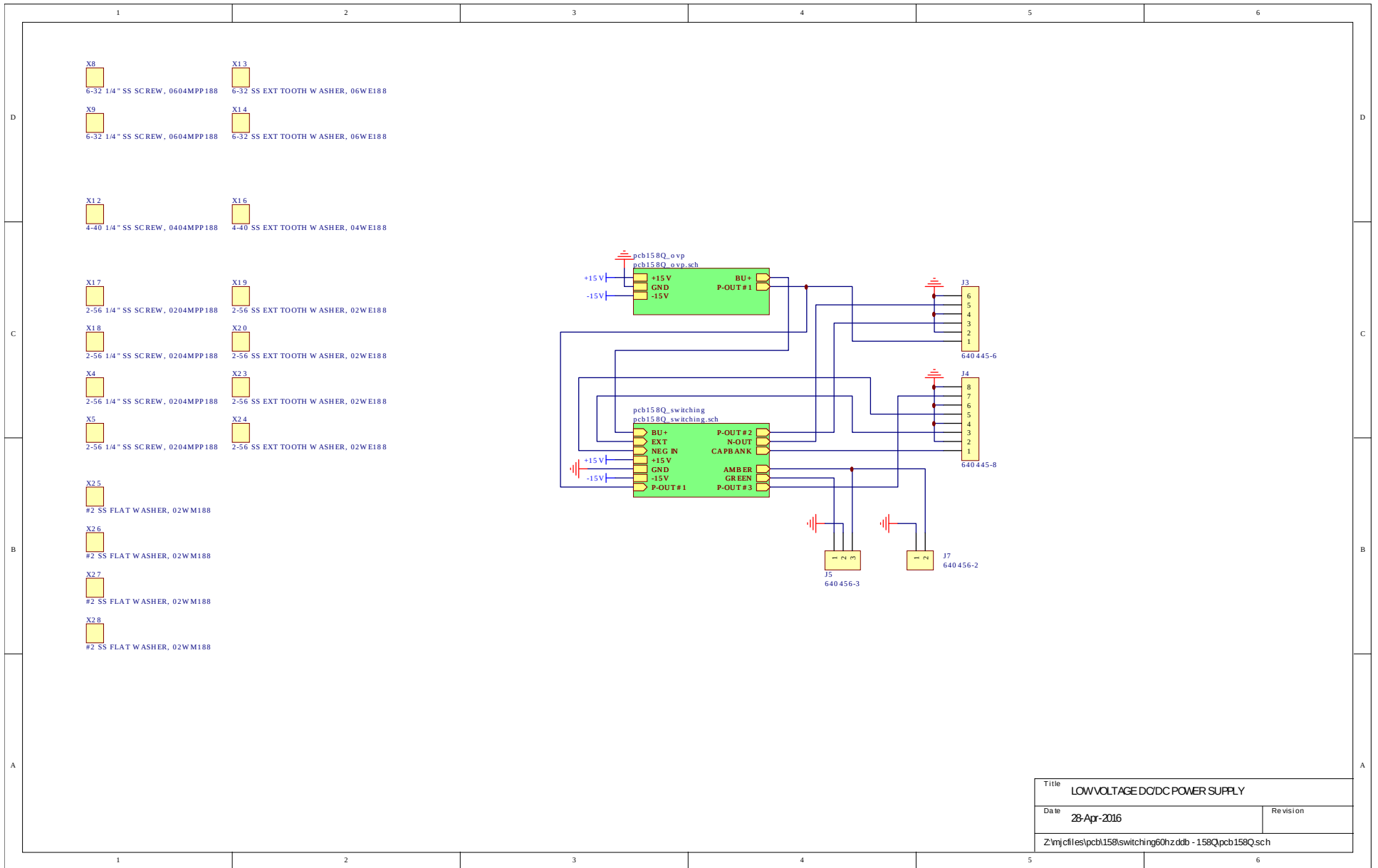

Title		LOW VOLTAGE DC/DC POWER SUPPLY
Date	28-Apr-2016	Revision
Z:\njcf\es\pcb158\switching60hzddb - 158Q.pcb158Q.sch		

# PCB 158Q - LOW VOLTAGE POWER SUPPLY, 2/3

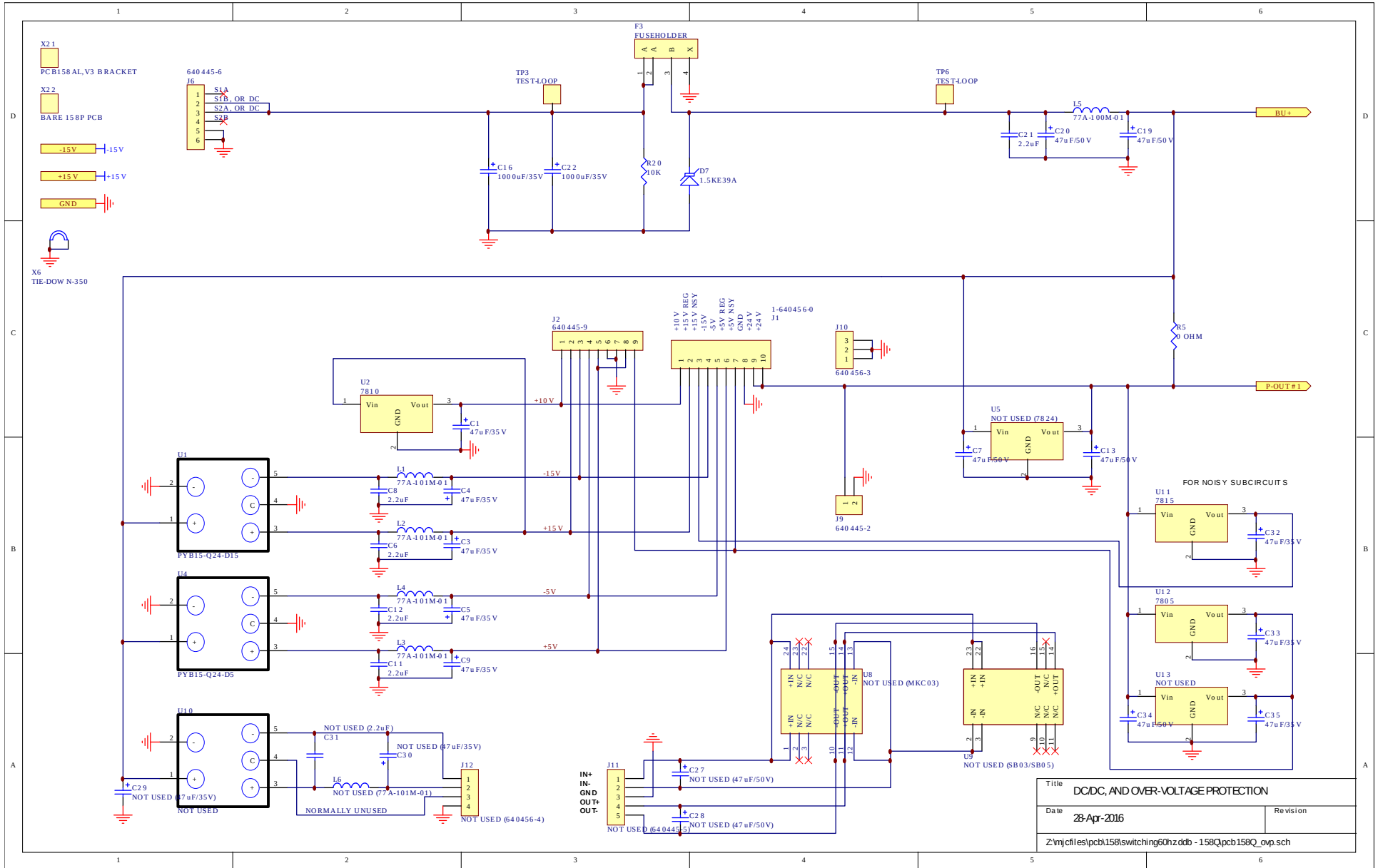

# PCB 158Q - LOW VOLTAGE POWER SUPPLY, 3/3

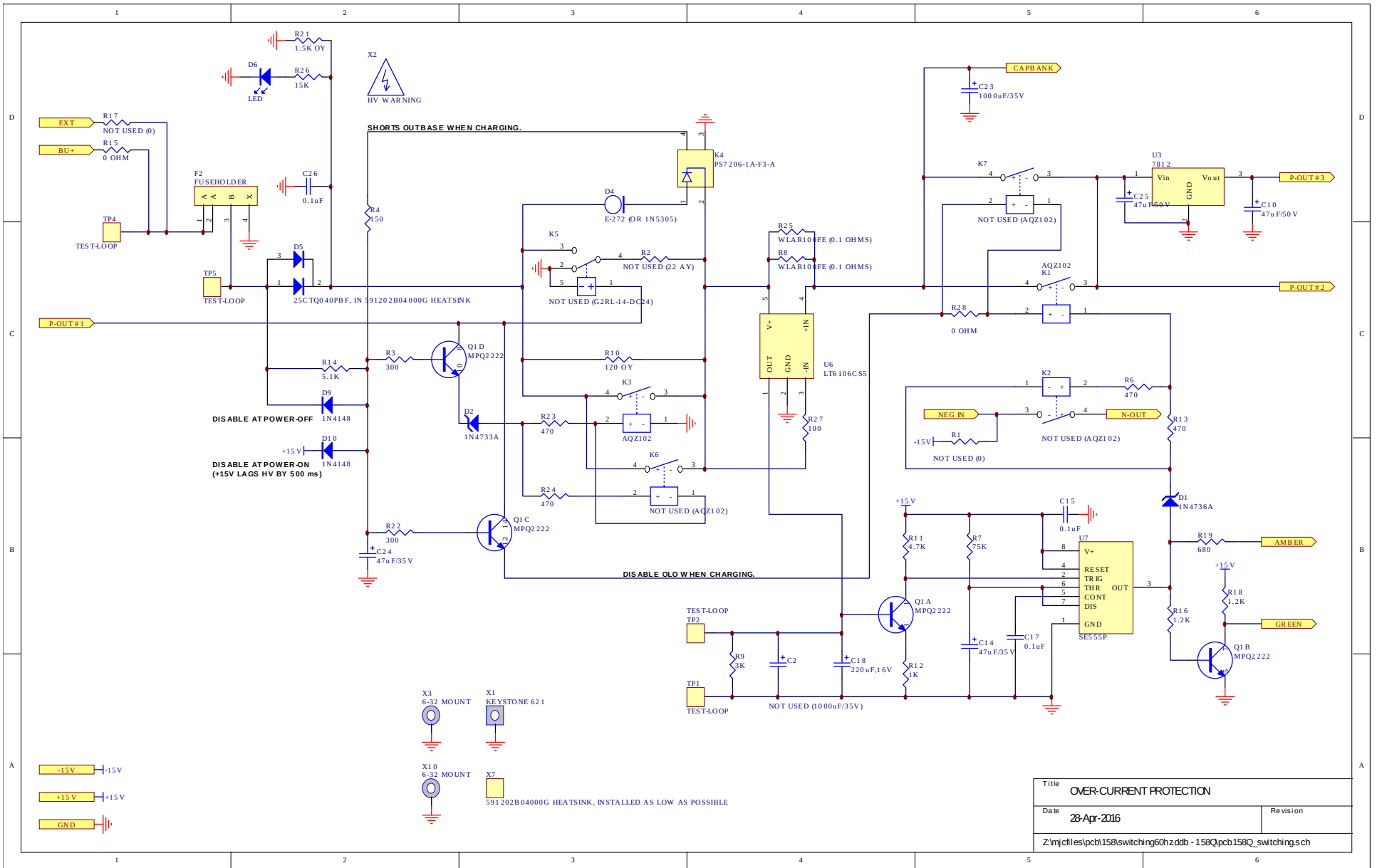



# PCB 235B - HIGH VOLTAGE DC POWER SUPPLY

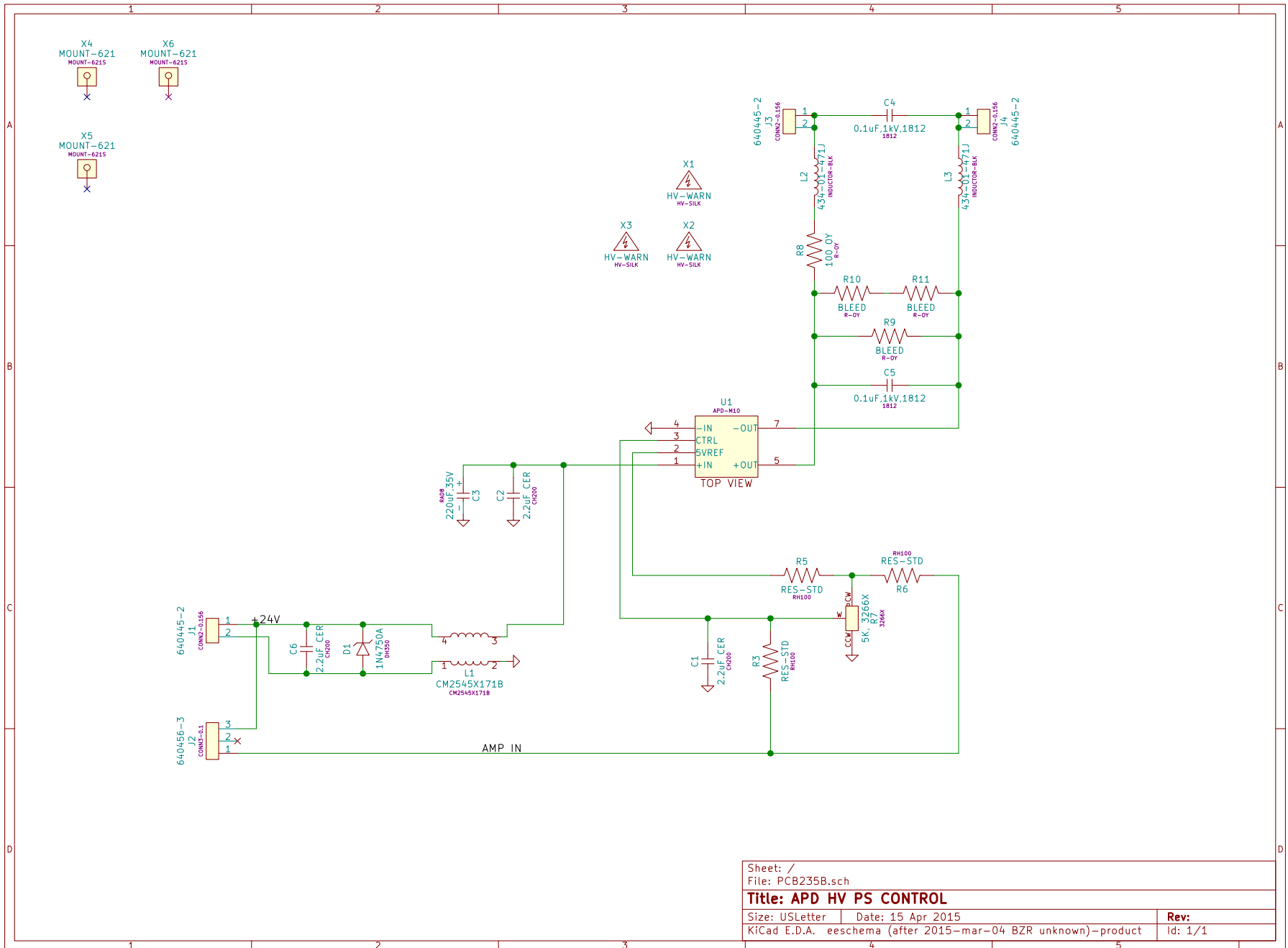

Sheet: /		File: PCB235B.sch	
<b>Title: APD HV PS CONTROL</b>			
Size: USLetter	Date: 15 Apr 2015	Rev:	
KICad E.D.A. eeschema (after 2015-mar-04 BZR unknown)-product			Id: 1/1

# PCB 231A - INTERNAL OFFSET GENERATOR

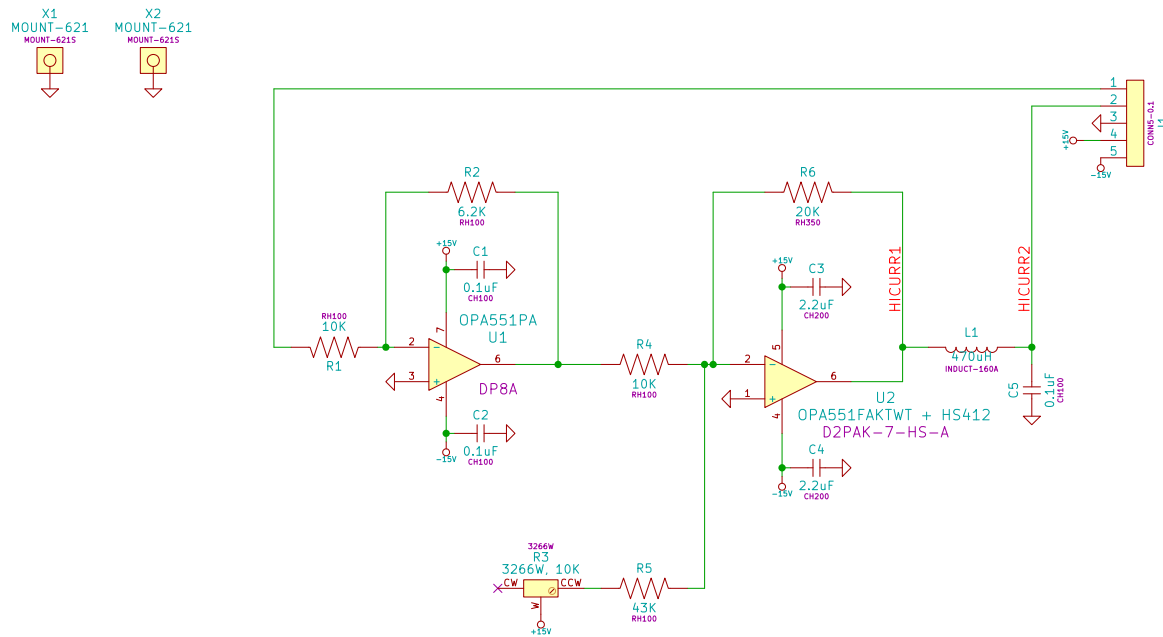

File: pcb231A.sch	
Sheet: /	
Title: -0T, -5V TO +5V OFFSET	
Size: A4	Date: 20 nov 2012
KiCad E.D.A.	Rev:
	Id: 1/1

# PCB 216E - PW/PRF TWEAK

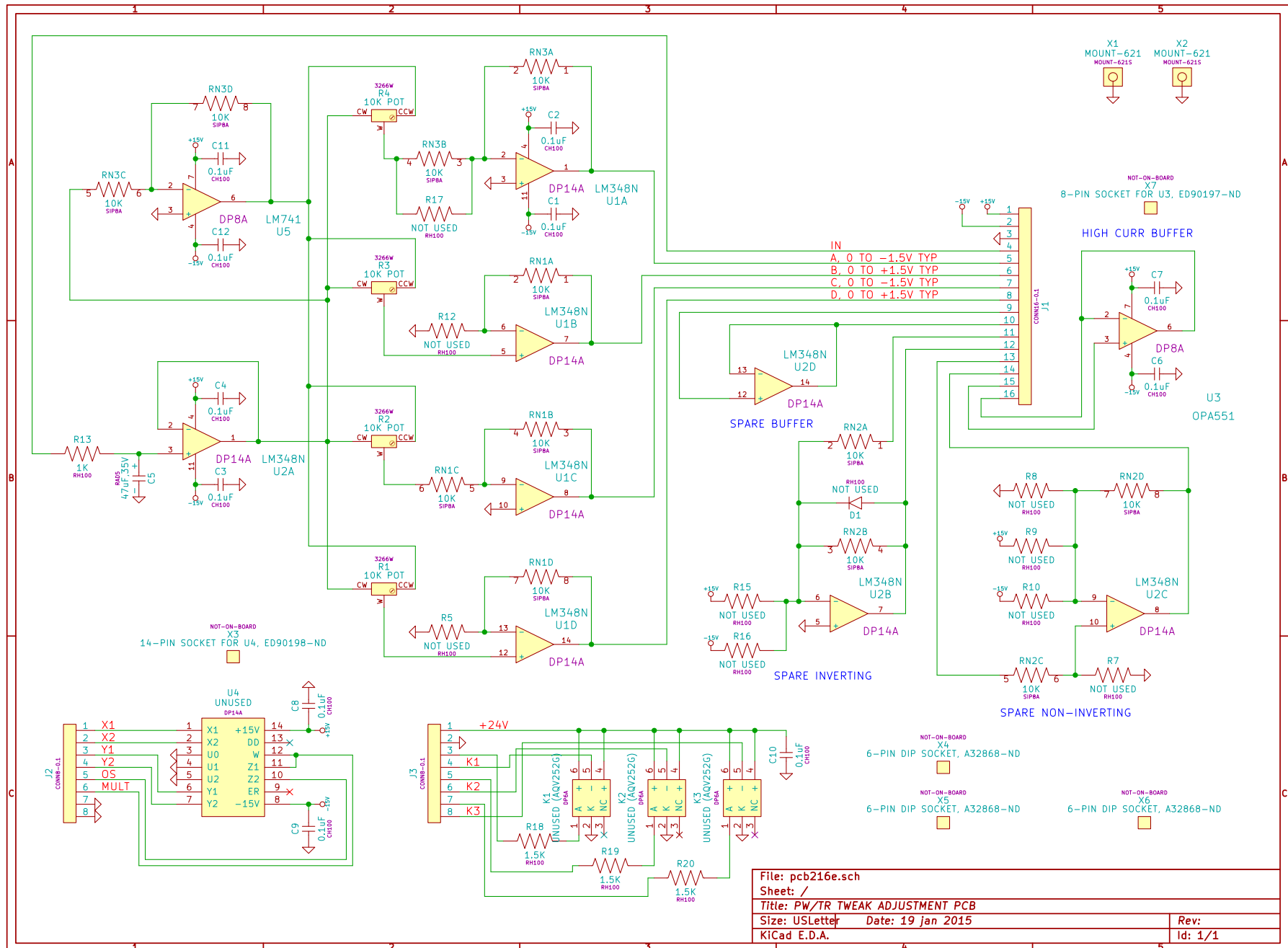

# PCB 104F - KEYPAD / DISPLAY BOARD, 1/3

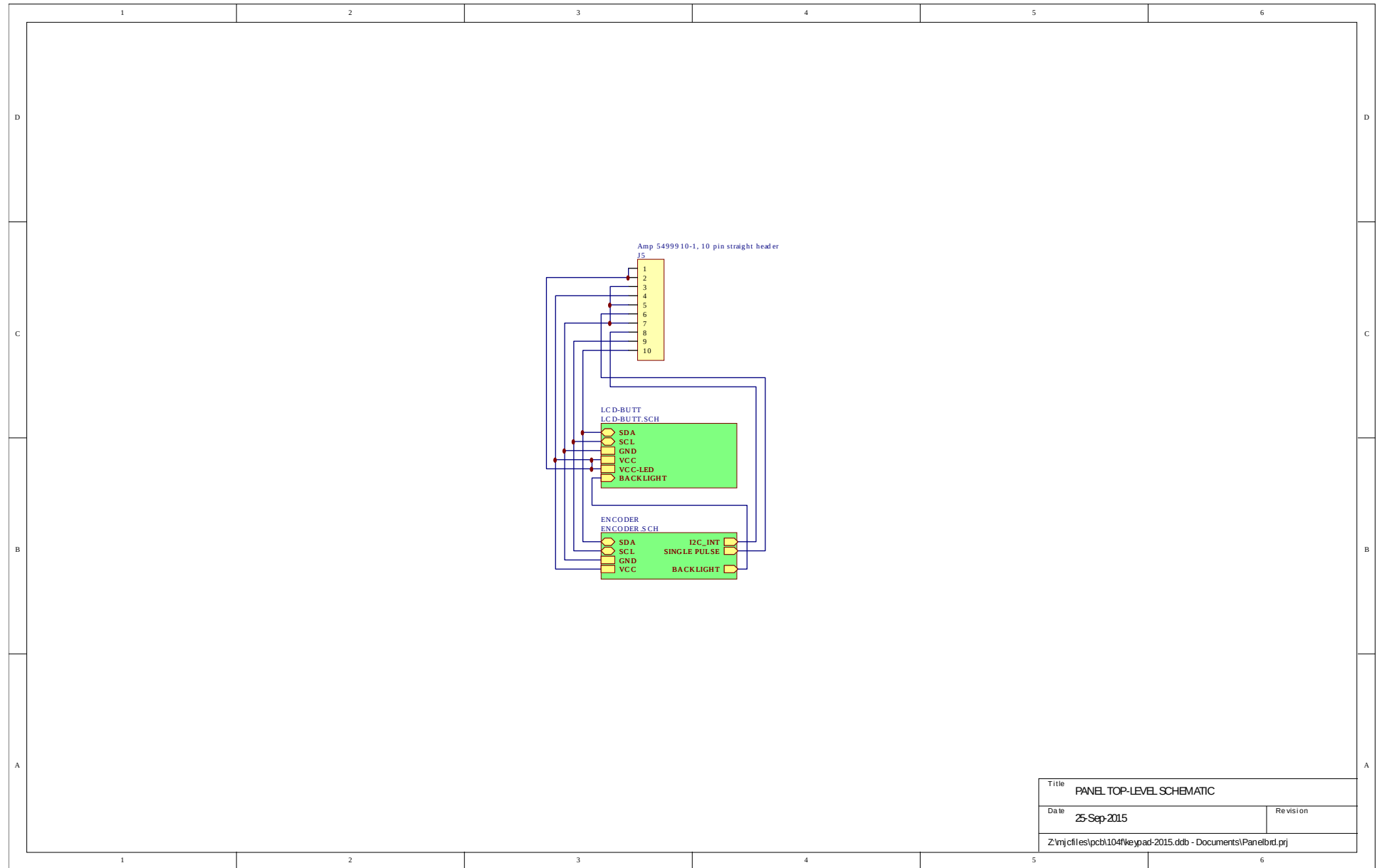

Title		PANEL TOP-LEVEL SCHEMATIC	
Date	25-Sep-2015	Revision	
Z:\njcf\es\pcb\104f\keypad-2015.ddb - Documents\Panelrd.prj			

# PCB 104F - KEYPAD / DISPLAY BOARD, 2/3

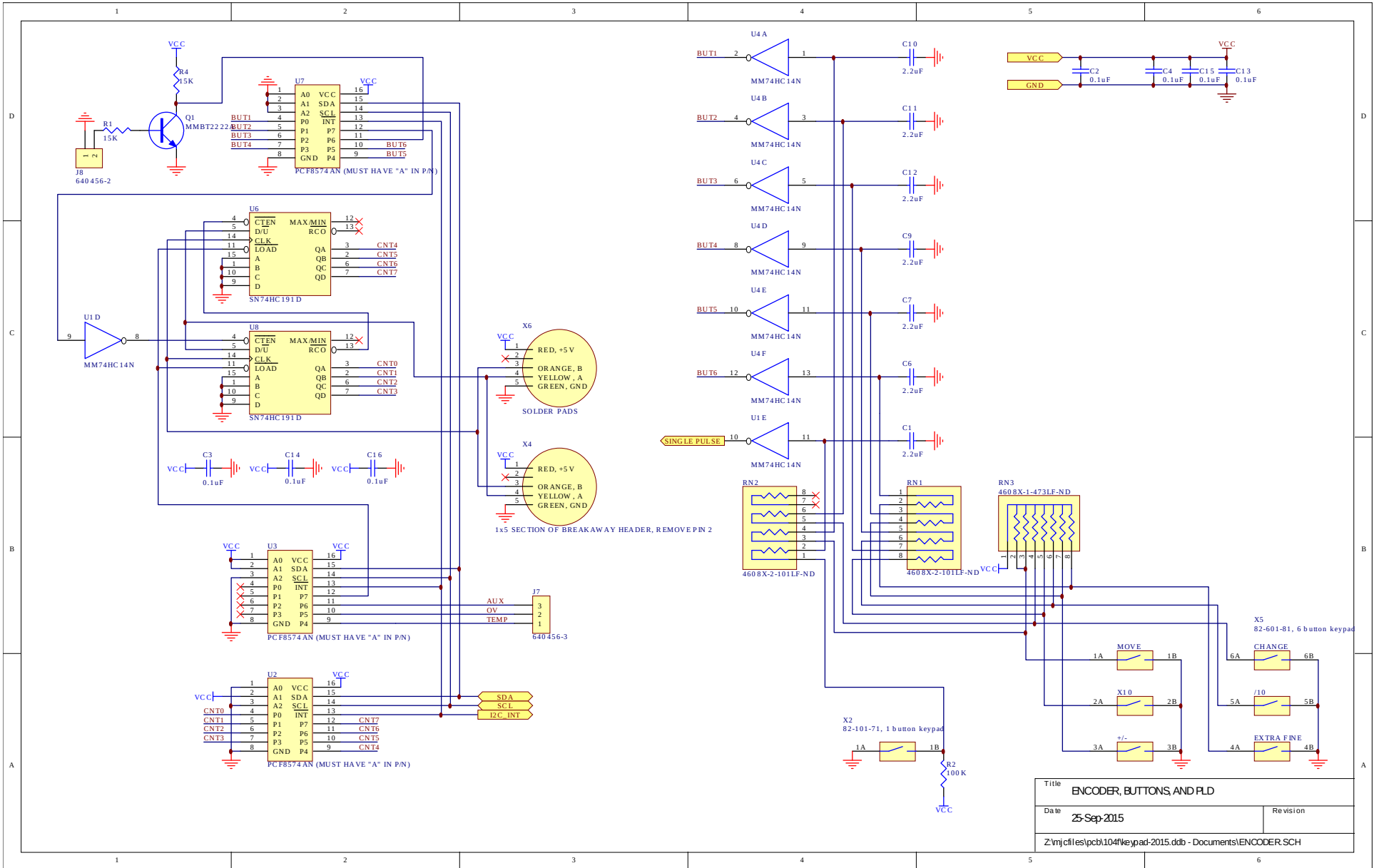

Title		ENCODER, BUTTONS, AND PLD	
Date	25-Sep-2015	Revision	
Z:\njc\files\pcb\104f\keypad-2015.ddb - Documents\ENCODER.SCH			

# PCB 104F - KEYPAD / DISPLAY BOARD, 3/3

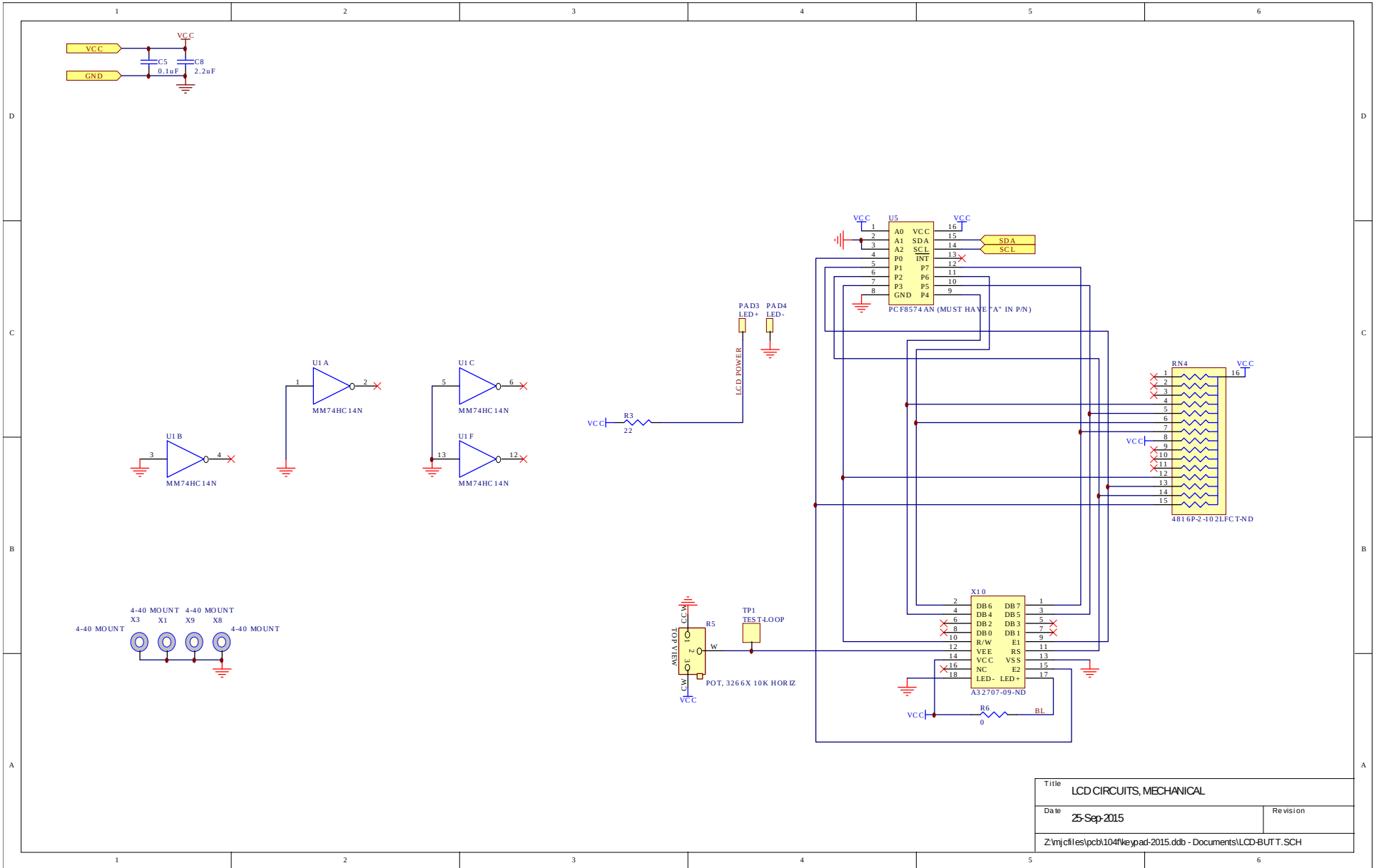

Title		LCD CIRCUITS, MECHANICAL	
Date	25-Sep-2015	Revision	
Z:\njcf\es\pcb\104f\ keypad-2015.ddb - Documents\LCD-BUT T.SCH			

# MAIN WIRING

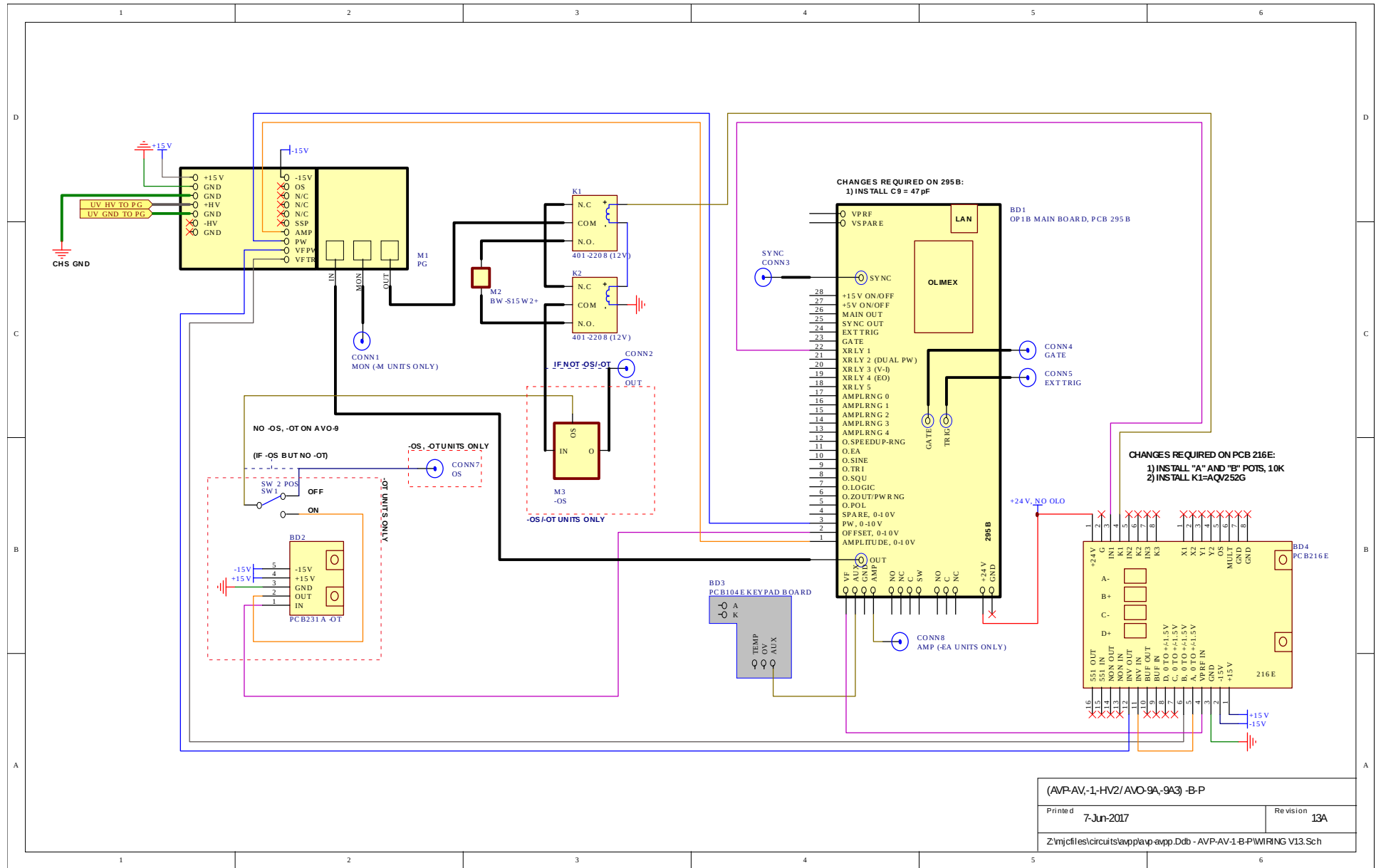

(AVP-AV-1-HV2/AVO-9A-9A3) -B-P	
Printed 7-Jun-2017	Revision 13A
Z:\mjcf\es\circuits\app\app.Ddb - AVP-AV-1-B-PIWIRNG V13.Sch	

PERFORMANCE CHECKSHEET