

INSTRUCTIONS

MODEL AVP-AV-1S-C-PN PULSE GENERATOR

S.N.:

WARRANTY

Avtech Electrosystems Ltd. warrants products of its manufacture to be free from defects in material and workmanship under conditions of normal use. If, within one year after delivery to the original owner, and after prepaid return by the original owner, this Avtech product is found to be defective, Avtech shall at its option repair or replace said defective item. This warranty does not apply to units which have been disassembled, modified or subjected to conditions exceeding the applicable specifications or ratings. This warranty is the extent of the obligation assumed by Avtech with respect to this product and no other warranty or guarantee is either expressed or implied.

TECHNICAL SUPPORT

Phone: 613-226-5772 or 1-800-265-6681

Fax: 613-226-2802 or 1-800-561-1970

E-mail: info@avtechpulse.com

World Wide Web: <http://www.avtechpulse.com>

TABLE OF CONTENTS

WARRANTY.....	2
TABLE OF CONTENTS.....	4
FIG. 1: PULSE GENERATOR TEST ARRANGEMENT.....	5
GENERAL OPERATING INSTRUCTIONS.....	6
FIG. 2: FRONT PANEL CONTROLS.....	8
FRONT PANEL CONTROLS.....	9
FIG. 3: BACK PANEL CONTROLS.....	12
BACK PANEL CONTROLS.....	13
FIG. 4: SYSTEM BLOCK DIAGRAM (POWER SUPPLY).....	14
FIG. 5: AVP-2S-PN-EA-EW-EO-C BLOCK DIAGRAM.....	15
FIG. 6: AVP-2S-C-PN BLOCK DIAGRAM.....	16
SYSTEM DESCRIPTION AND REPAIR PROCEDURE.....	17
POWER SUPPLY AND FUSE REPLACEMENT.....	18
PERFORMANCE CHECK SHEET.....	20

FIG. 1: PULSE GENERATOR TEST ARRANGEMENT

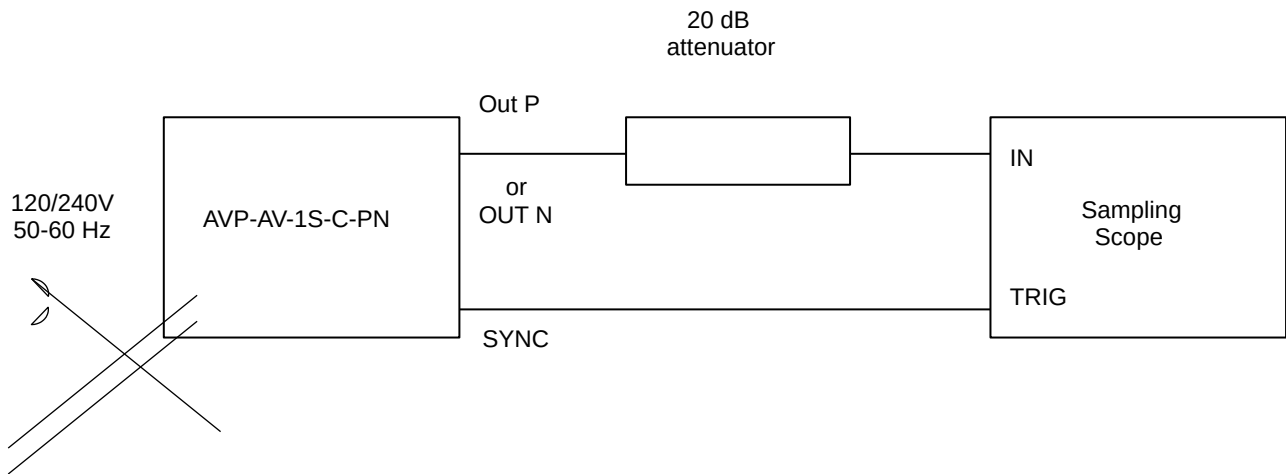

GENERAL OPERATING INSTRUCTIONS

- 1) The bandwidth capability of components and instruments used to display the pulse generator output signal (attenuators, cables, connectors, etc.) should exceed 18 GHz.
- 2) The use of 20 dB attenuator at the scope vertical input channel will insure a peak input signal to the scope of less than one Volt.
- 3) The sync output channel provides a 500 mV 20 ns wide pulse to fifty Ohms. The sampling scope should be set to trigger on the positive edge of the sync pulse.
- 4) The desired output polarity is selected by means of the front panel POLARITY switch. With the POLARITY switch in the P position, the negative output pulse generator is rendered inactive. Likewise, with the POLARITY switch in the N position, the positive pulse generator is rendered inactive.
- 5) To obtain a stable output display the PW and PRF controls on the front panel should be set mid range. The front panel TRIG toggle switch should be in the INT position. The DELAY controls and the scope triggering controls are then adjusted to obtain a stable output. The scope may then be used to set the desired PRF by rotating the PRF controls.
- 6) The output pulse widths for the positive and negative outputs are controlled by means of the front panel one turn PW P and PW N controls.
- 7) The output pulse amplitudes for the positive and negative outputs are controlled by means of the front panel one turn AMP P and AMP N controls. Some properties of the output pulse may change as a function of the amplitude pot setting. For some demanding applications, it may be desirable to use a combination of external attenuators and the amplitude pot to achieve the desired output amplitude.
- 8) To voltage control the output pulse width, set the rear panel switch in the EXT position and apply 0 to +10V between terminal A and ground ($R_{IN} \geq 10K$). (option).
- 9) To voltage control the output amplitude, set the rear panel switch in the EXT position and apply 0 to +10V between terminal A and ground ($R_{IN} \geq 10K$). (option).

- 10) For units with the OT or EO options, the output DC offset is variable from +5 to -5 Volts by means of the front panel one turn OFFSET control. The offset control may be turned off by means of the ON-OFF OFFSET switch.
- 11) For units with the EO option, the output offset may be voltage controlled by setting the rear panel switch in the EXT position and applying 0 to +10V between terminal A and ground ($R_{IN} \geq 10K$). (option).
- 12) An external clock may be used to control the output PRF of the AVR unit by setting the front panel TRIG toggle switch in the EXT position and applying a 0.2 us (approx) TTL level pulse to the TRIG BNC connector input. For operation in this mode, the scope time base must also be triggered by the external clock rather than from the SYNC output.
- 13) The AVP-C unit can be converted from 120 to 240V 50-60 Hz operation by adjusting the voltage selector card in the rear panel fused voltage selector-cable connector assembly.

14) For additional assistance:

Tel: (613) 226-5772

Fax: (613) 226-2802

Email: info@avtechpulse.com

FIG. 2: FRONT PANEL CONTROLS

FRONT PANEL CONTROLS

- 1) ON-OFF Switch. Applies basic prime power to all stages.
- 2) PRF Control. Varies PRF from 1.0 kHz to 1.0 MHz as follows:

Range 1	1.6 kHz	8 kHz
Range 2	8 kHz to	40 kHz
Range 3	40 kHz to	200 kHz
Range 4	200 kHz to	1.0 MHz
- 1) DELAY Control. Controls the relative delay between the reference output pulse provided at the SYNC output (4) and the main outputs (5) and (6). This delay is variable over the range of 0 to about 150 ns.
- 2) SYNC Output. This output precedes the main output (5) and (6) and is used to trigger the scope time base. The output is a 500 mV 20 ns (approx) pulse capable of driving a fifty Ohm load. Set scope to trigger on positive edge.
- 3) OUT N Connector. SMA connector provides output to a fifty Ohm load.
- 4) OUT P Connector. SMA connector provides output to a fifty Ohm load.
- 5) PW P Control. A one turn control which varies the positive output pulse width.
- 6) PW N Control. A one turn control which varies the negative output pulse width.
- 7) AMP P Control. A one turn control which varies the positive output pulse amplitude.
- 8) AMP N Control. A one turn control which varies the negative output pulse amplitude.
- 9) POLARITY Control. With the switch in the P position, the negative output pulse generator is rendered inactive. With the switch in the N position, the positive output pulse generator is rendered inactive.
- 10) EXT-INT Control. With this toggle switch in the INT position, the PRF of the AVP unit is controlled via an internal clock which in turn is controlled by the PRF controls. With the toggle switch in the EXT position, the AVP unit requires a 50 ns (or wider) TTL level pulse applied at the TRIG input in order to trigger the output stages. In addition, in this

mode, the scope time base must be triggered by the external trigger source.

- 11) TRIG Input. The external trigger signal is applied at this input when the EXT-INT toggle switch is in the EXT position.
- 12) OFFSET. One turn control varies output DC offset from -5 to +5 Volts to 50 Ohms. Two position switch turns offset "ON" or "OFF".

FIG. 3: BACK PANEL CONTROLS

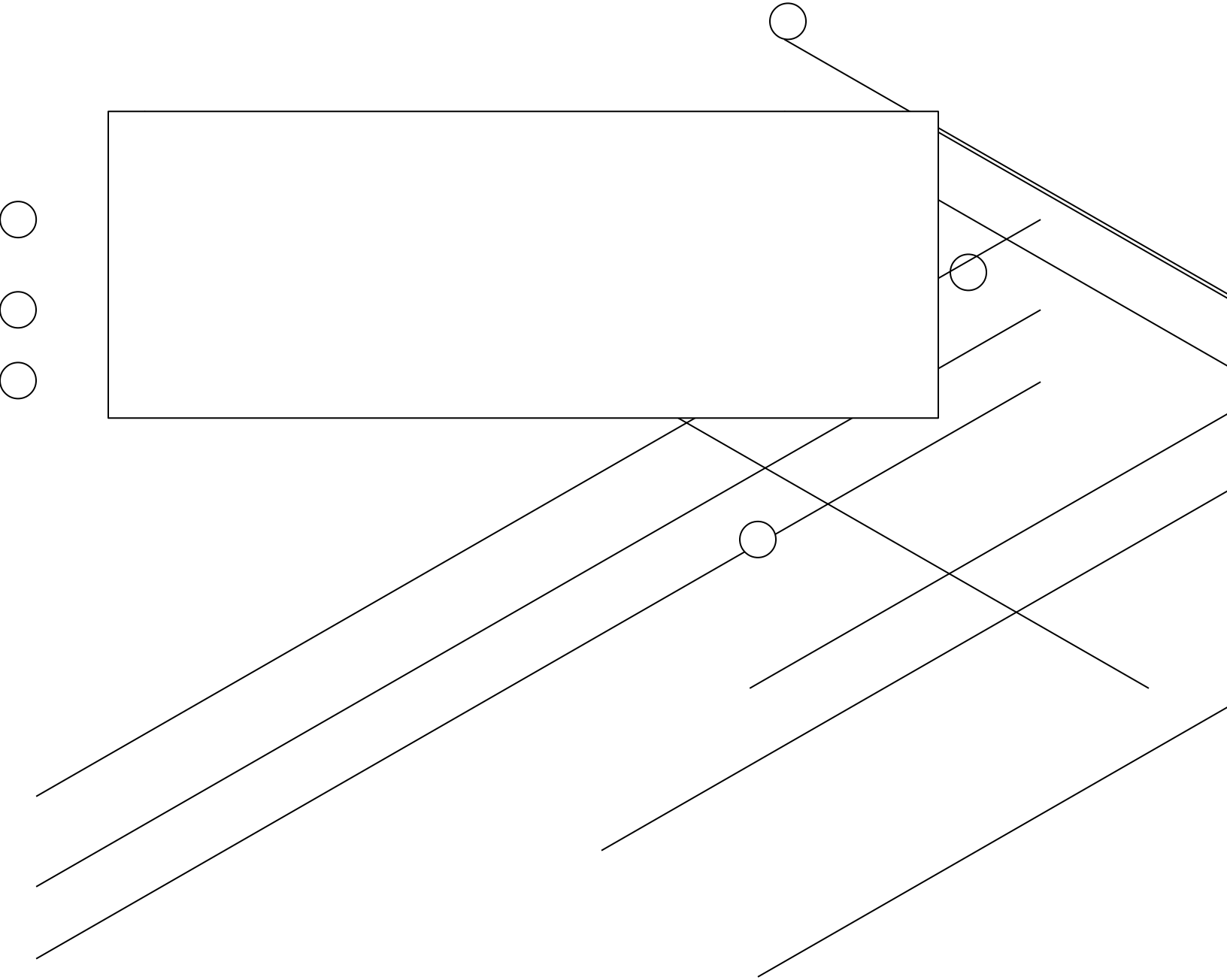

BACK PANEL CONTROLS

- 1) FUSED CONNECTOR, VOLTAGE SELECTOR. The detachable power cord is connected at this point. In addition, the removable cord is adjusted to select the desired input operating voltage. The unit also contains the main power fuse (0.25A SB).
- 2) OS. To voltage control the output DC offset, set the switch in the EXT position and apply 0 to +10 Volts between terminal A and ground ($R_{IN} \geq 10K$). (option).
- 3) With the front panel OFFSET ON-OFF switch in ON position, DC output offset potential appears at this terminal. (EO or OT options).
- 4) EA. To voltage control the output amplitude, set the switch in the EXT position and apply 0 to +10 Volts between terminal A and ground ($R_{IN} \geq 10K$). (option).
- 5) EW. To voltage control the output pulse width, set the switch in the EXT position and apply 0 to +10 Volts between terminal A and ground ($R_{IN} \geq 10K$). (option).
- 6) MONITOR OUT M. Provides an attenuated (x10) coincident replica of the main positive output pulse to fifty Ohms. (option).

FIG. 4: SYSTEM BLOCK DIAGRAM (POWER SUPPLY)

FIG. 5: AVP-2S-PN-EA-EW-EO-C BLOCK DIAGRAM

FIG. 6: AVP-2S-C-PN BLOCK DIAGRAM

SYSTEM DESCRIPTION AND REPAIR PROCEDURE

The AVP-AV-1S-C-PN consists of:

- a) AVP-1S-PG pulse generator modules (positive and negative)
- b) AVP-1S-CL clock module
- c) AVP-OT offset module (option)
- d) AVP-1S-PS -5.0 Volt power supply module
- e) +24 and +15 Volt power supply board

In the event that the unit malfunctions, remove the instrument cover by removing the four Phillips screws on the back of the unit. The top cover may then be slid off. Measure the voltage at the +15V pin of the PG module. If this voltage is substantially less than +15 Volts, unsolder the line connecting the power supply and PG modules and connect 50 Ohm 10 W load to the PS output. The voltage across this load should be about +15V DC. If this voltage is substantially less than 15 Volts the PS module is defective and should be repaired or replaced. If the voltage across the resistor is near 15 Volts, then the PG module should be replaced or repaired. The sealed PG module must be returned to Avtech for repair (or replacement). The clock module provides a TTL level trigger pulse at pin 2 to trigger the PG module and a 20 ns 500 mV sync pulse at pin 3 to trigger the sampling scope display device. The output at pin 3 precedes the output at pin 2 by almost 0 to 100 ns depending on the DELAY control setting. With the INT-EXT switch in the EXT position, the clock module is disconnected from the PG module. The clock module is functioning properly if:

- a) TTL level and 20 ns 500 mV outputs are observed at pins 2 and 3, respectively.
- b) The PRF of the outputs can be varied over the range of 1 kHz to 1 MHz using the PRF control.
- c) The relative delay between the pin 2 and 3 outputs can be varied by at least 500 ns by the DELAY controls.

The sealed clock module must be returned to Avtech for repair or replacement if the above conditions are not observed.

POWER SUPPLY AND FUSE REPLACEMENT

This instrument has three fuses (plus one spare). One, which protects the AC input, is located in the rear-panel power entry module, as described in the “Rear Panel Controls” section of this manual. If the power appears to have failed, check the AC fuse first.

The other two fuses (plus one spare) are located on the internal DC power supply, as shown below:

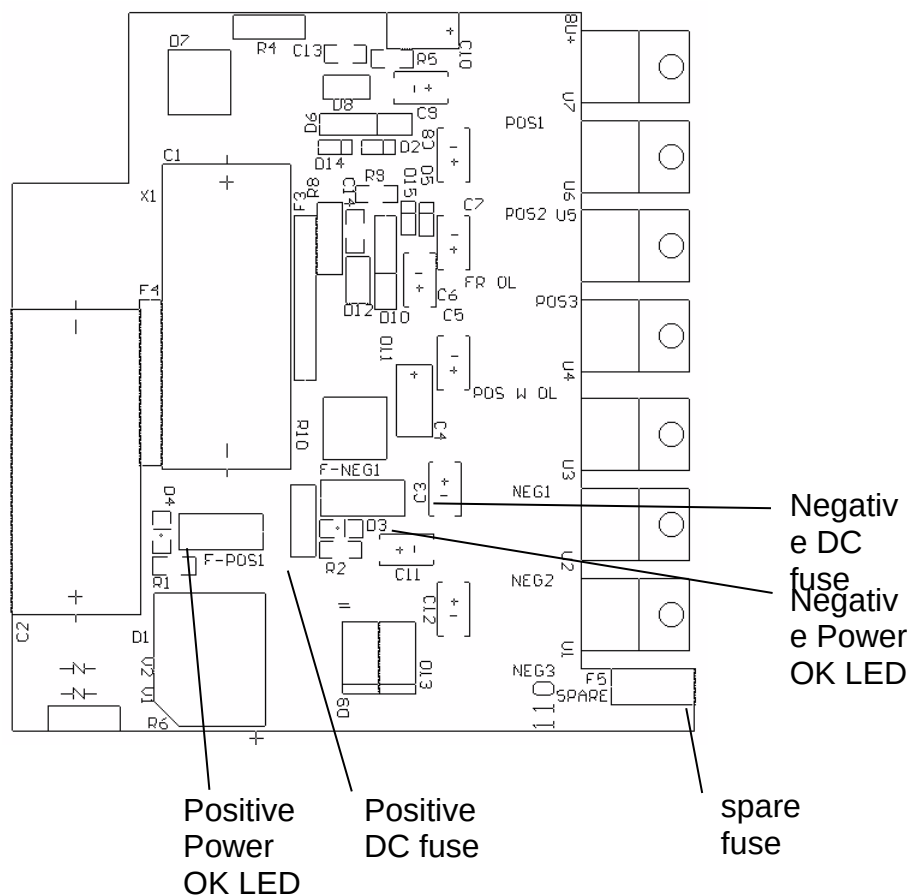

The spare fuse may be used to replace one of the other fuses, if required.

The three fuses on this circuit board are 0.5A slow-blow fuses, Littlefuse part number R452.500. (This fuse can be ordered from Digikey, www.digikey.com. The Digikey part number is F1341CT-ND).

If you suspect that the DC fuses are blown, follow this procedure:

- 1 Remove the top cover, by removing the four Phillips screws on the top cover and then sliding the cover back and off.
- 2 Locate the two "Power OK" LEDs on the power supply circuit board, as illustrated above.
- 3 Turn on the instrument.
- 4 Observe the "Power OK" LEDs. If the fuses are not blown, the two LEDs will be lit (bright red). If one of the LEDs is not lit, the fuse next to it has blown.
- 5 Turn off the instrument.
- 6 If a fuse is blown, use needle-nose pliers to remove the blown fuse from its surface-mount holder.
- 7 Replace the fuse.

PERFORMANCE CHECK SHEET