



AVTECH ELECTROSYSTEMS LTD.

NANOSECOND WAVEFORM ELECTRONICS
SINCE 1975

P.O. BOX 265
OGDENSBURG, NY
U.S.A. 13669-0265

TEL: 888-670-8729 (USA & Canada) or +1-613-226-5772 (Intl)
FAX: 800-561-1970 (USA & Canada) or +1-613-226-2802 (Intl)

info@avtechpulse.com - <http://www.avtechpulse.com/>

BOX 5120, LCD MERIVALE
OTTAWA, ONTARIO
CANADA K2C 3H4

INSTRUCTIONS

MODEL AVP-AV-2
0 to 10V, 2 to 50 ns
PULSE GENERATOR
WITH 100 ps RISE TIME

SERIAL NUMBER: _____

WARRANTY

Avtech Electrosystems Ltd. warrants products of its manufacture to be free from defects in material and workmanship under conditions of normal use. If, within one year after delivery to the original owner, and after prepaid return by the original owner, this Avtech product is found to be defective, Avtech shall at its option repair or replace said defective item. This warranty does not apply to units which have been disassembled, modified or subjected to conditions exceeding the applicable specifications or ratings. This warranty is the extent of the obligation assumed by Avtech with respect to this product and no other warranty or guarantee is either expressed or implied.

TECHNICAL SUPPORT

Phone: 888-670-8729 (USA & Canada) or +1-613-226-5772 (Intl)

Fax: 800-561-1970 (USA & Canada) or +1-613-226-2802 (Intl)

E-mail: info@avtechpulse.com

World Wide Web: <http://www.avtechpulse.com>

TABLE OF CONTENTS

WARRANTY.....2

TECHNICAL SUPPORT.....2

TABLE OF CONTENTS.....3

INTRODUCTION.....4

AVAILABLE OPTIONS.....4

SPECIFICATIONS.....5

EUROPEAN REGULATORY NOTES.....6

EC DECLARATION OF CONFORMITY.....6

DIRECTIVE 2002/95/EC (RoHS).....6

DIRECTIVE 2002/96/EC (WEEE).....6

BASIC TEST ARRANGEMENT.....8

CONTROLS - FRONT.....8

CONTROLS - REAR.....9

GENERAL OPERATING NOTES.....9

PERFORMANCE CHECK SHEET.....11

Manual Reference: /filesserver1/officefiles/instructword/avp/AVP-AV-2,ed3.odt.
Last modified February 29, 2024.
Copyright © 2024 Avtech Electrosystems Ltd, All Rights Reserved.

INTRODUCTION

The AVP-AV-2 is a high performance DC-powered module capable of generating up to 10V into 50 Ω loads at repetition rates up to 50 kHz. The rise time is less than 100 ps, and the fall time is less than 200 ps. The pulse width is variable from 2 to 50 ns.

Instruments with the "-P" model suffix can generate 0 to +10V, whereas instruments with the "-N" model suffix can generate 0 to -10V.

The AVP-AV-2 must be triggered by an external TTL pulse (> 50 ns) applied to the "IN" connector.

The output is designed to drive 50 Ω loads. (A 50 Ω load is required for proper operation.) The output is AC-coupled.

This instrument is intended for use in research and development laboratories.

AVAILABLE OPTIONS

The AVP-AV-2 is available with several options:

- EA Option: the output amplitude can be controlled by an externally generated 0 to +10V analog control voltage.
- ECL Option: the input trigger levels are ECL, rather than TTL.
- EW Option: the output pulse width can be controlled by an externally generated 0 to +10V analog control voltage.
- M Option: a monitor output is provided.
- OS Option: an externally generated DC offset can be added to the output.

SPECIFICATIONS

Model:	AVP-AV-2
Amplitude ^{1,2} : (50 Ohm load)	0 to 10 Volts
Pulse width ¹ : (FWHM)	2 – 50 ns
PRF:	0 Hz to 50 kHz
Rise time (20%-80%):	≤ 100 ps
Fall time (80%-20%):	≤ 200 ps
Polarity:	Specify -P or -N
Propagation delay:	≤ 250 ns
Jitter, Ext trig in to pulse out:	±15 ps
DC offset or bias insertion:	Option available. Apply required DC offset or bias in the range of ± 50 Volts (250 mA max) to back panel solder terminal. See note 3.
Trigger required:	+5 Volt, 50 ns to 500 ns (TTL). ECL trigger option available. See note 5.
Monitor output option ⁴ :	Provides a 20 dB (x10) attenuated coincident replica of main output
Connectors: OUT, MONITOR ⁴ : TRIG: DC POWER:	SMA SMA solder terminals
Power requirement:	+15 Volt, 400 mA
Dimensions (H x W x D):	1.7" x 3.0" x 6.0"
Chassis material:	Cast aluminum, blue enamel
Mounting, Temperature range:	Any, +5°C to +40°C

- 1) For analog electronic control (0 to +10V) of amplitude or pulse width suffix model number with -EA or -EW. Electronic control units also include standard front-panel controls.
- 2) For operation at amplitudes of less than 20% of full-scale, best results will be obtained by setting the amplitude near full-scale and using external attenuators on the output.
- 3) For externally applied DC offset option suffix model number with -OS. The Avtech AVX-T bias tee can also be used to obtain DC offset..
- 4) For monitor option add suffix -M.
- 5) For ECL trigger option, add suffix -ECL.

EUROPEAN REGULATORY NOTES

EC DECLARATION OF CONFORMITY

We Avtech Electrosystems Ltd.
P.O. Box 5120, LCD Merivale
Ottawa, Ontario
Canada K2C 3H4

declare that this pulse generator meets the intent of Directive 89/336/EEC for Electromagnetic Compatibility. Compliance pertains to the following specifications as listed in the official Journal of the European Communities:

EN 50081-1 Emission

EN 50082-1 Immunity

and that this pulse generator meets the intent of the Low Voltage Directive 72/23/EEC as amended by 93/68/EEC. Compliance pertains to the following specifications as listed in the official Journal of the European Communities:

EN 61010-1:2001 Safety requirements for electrical equipment for measurement, control, and laboratory use



DIRECTIVE 2002/95/EC (RoHS)

This instrument is exempt from Directive 2002/95/EC of the European Parliament and of the Council of 27 January 2003 on the Restriction of the use of certain Hazardous Substances (RoHS) in electrical and electronic equipment. Specifically, Avtech instruments are considered "Monitoring and control instruments" (Category 9) as defined in Annex 1A of Directive 2002/96/EC. The Directive 2002/95/EC only applies to Directive 2002/96/EC categories 1-7 and 10, as stated in the "Article 2 - Scope" section of Directive 2002/95/EC.

DIRECTIVE 2002/96/EC (WEEE)

European customers who have purchased this equipment directly from Avtech will have completed a "WEEE Responsibility Agreement" form, accepting responsibility for WEEE

compliance (as mandated in Directive 2002/96/EC of the European Union and local laws) on behalf of the customer, as provided for under Article 9 of Directive 2002/96/EC.

Customers who have purchased Avtech equipment through local representatives should consult with the representative to determine who has responsibility for WEEE compliance. Normally, such responsibilities will lie with the representative, unless other arrangements (under Article 9) have been made.

Requirements for WEEE compliance may include registration of products with local governments, reporting of recycling activities to local governments, and financing of recycling activities.

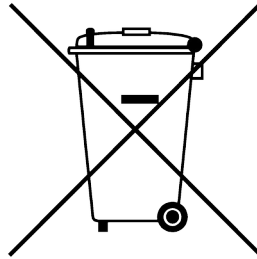

BASIC TEST ARRANGEMENT

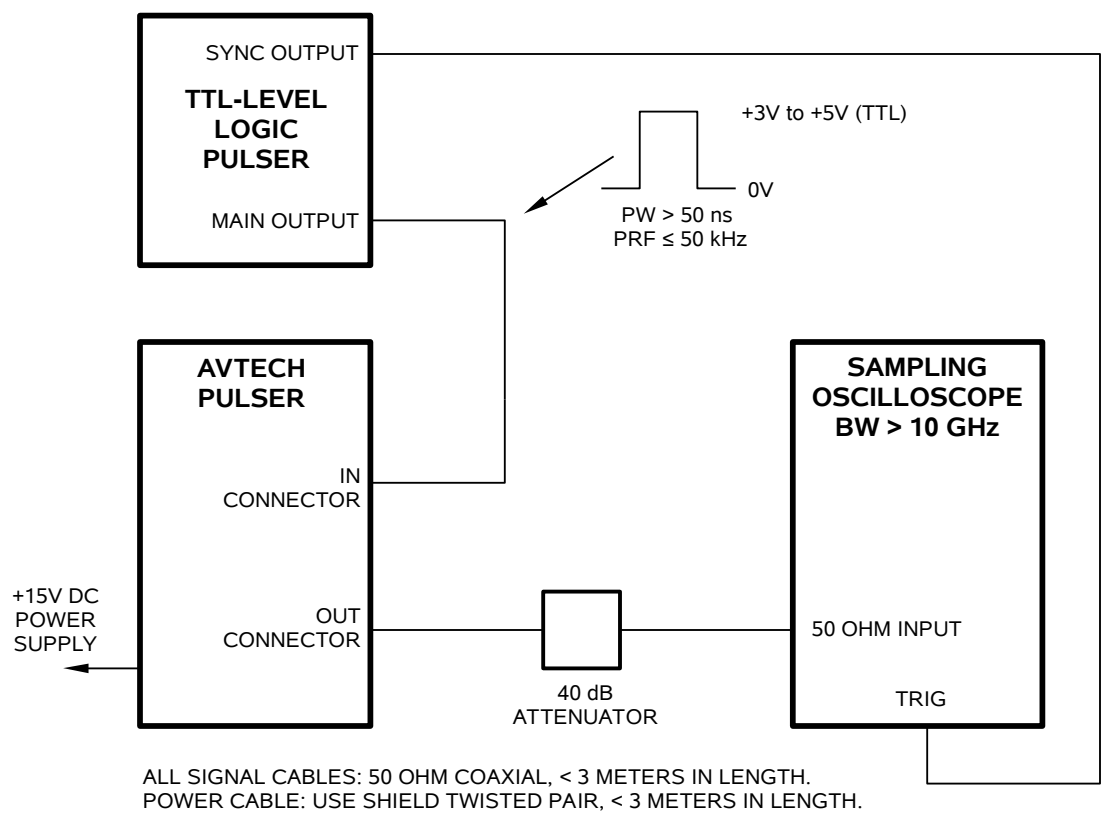

CONTROLS - FRONT

The location of the IN and OUT connectors and the amplitude and pulse width controls are shown in the photo below.



The “AMP” and “PW” controls may be adjusted using a screwdriver.

Units with the -EA option will have a solder terminal to control the amplitude, rather than a screwdriver-adjustable trimpot. The amplitude is then controlled by a 0 to +10V DC voltage applied to the solder terminal.

Units with the -EW option will have a solder terminal to control the pulse width, rather than a screwdriver-adjustable trimpot. The pulse width is then controlled by a 0 to +10V DC voltage applied to the solder terminal.

Units with the -M option will have an additional output connector (“M”) between the IN and OUT connectors.

CONTROLS - REAR

The location of the power terminals are shown in the photo below.



The +15V input terminal is protected with a 1N4746A Zener diode, which will fail as a short if an excessive positive voltage (> 18V), or a negative voltage, is applied to the terminal.

GENERAL OPERATING NOTES

- 1) The bandwidth capability of components and instruments used to display the pulse generator output signal (attenuators, cables, connectors, etc.) should exceed 10 GHz.

- 2) The use of 40 dB attenuator on the output will ensure a peak input signal to the sampling scope of less than one volt.
- 3) In general, the source pulse generator trigger delay control should be set in the 0.1 to 1.0 us range, for proper positioning of the output pulse on the sampling oscilloscope display.
- 4) WARNING: The module may fail if triggered at a PRF greater than 50 kHz.
- 5) The output pulse width is controlled by means of the one turn potentiometer (PW). The pot should initially be set maximum clockwise and the pulse width adjusted using an oscilloscope.
- 6) The output pulse amplitude is controlled by means of the one turn potentiometer (AMP). The pulse width may change by several nanoseconds as the output amplitude is reduced from maximum to minimum. Therefore it is convenient to first set the desired amplitude and then set the desired pulse width. Rotation of the PW pot causes the position of the falling edge of the pulse to change.
- 7) Some properties of the output pulse may change as a function of the amplitude pot setting. For some demanding applications, it may be desirable to use a combination of external attenuators and the amplitude pot to achieve the desired output amplitude.
- 8) To DC offset the output pulse connect a DC power supply set to required DC offset value to the terminals marked "OS". The maximum attainable DC offset voltage is +50 volts. (Option).
- 9) The monitor output port (M) provides a coincident attenuated ($\div 10$) replica of the main output to a 50 ohm load. (Option).

PERFORMANCE CHECK SHEET