



AVTECH ELECTROSYSTEMS LTD.

NANOSECOND WAVEFORM ELECTRONICS
SINCE 1975

P.O. BOX 265
OGDENSBURG, NY
U.S.A. 13669-0265

TEL: 888-670-8729 (USA & Canada) or +1-613-686-6675 (Intl)
FAX: 800-561-1970 (USA & Canada) or +1-613-686-6679 (Intl)

info@avtechpulse.com - <http://www.avtechpulse.com/>

BOX 5120, LCD MERIVALE
OTTAWA, ONTARIO
CANADA K2C 3H5

INSTRUCTIONS

MODEL AVP-AV-HV3-C

40 VOLT, 1 MHz

HIGH SPEED PULSE GENERATOR

WITH 150 ps RISE TIMES

SERIAL NUMBER: _____

WARRANTY

Avtech Electrosystems Ltd. warrants products of its manufacture to be free from defects in material and workmanship under conditions of normal use. If, within one year after delivery to the original owner, and after prepaid return by the original owner, this Avtech product is found to be defective, Avtech shall at its option repair or replace said defective item. This warranty does not apply to units which have been disassembled, modified or subjected to conditions exceeding the applicable specifications or ratings. This warranty is the extent of the obligation assumed by Avtech with respect to this product and no other warranty or guarantee is either expressed or implied.

TECHNICAL SUPPORT

Phone: 888-670-8729 (USA & Canada) or +1-613-686-6675 (International)

Fax: 800-561-1970 (USA & Canada) or +1-613-686-6679 (International)

E-mail: info@avtechpulse.com

World Wide Web: <http://www.avtechpulse.com>

TABLE OF CONTENTS

WARRANTY.....	2
TECHNICAL SUPPORT.....	2
TABLE OF CONTENTS.....	3
INTRODUCTION.....	5
AVAILABLE OPTIONS.....	6
SPECIFICATIONS.....	7
REGULATORY NOTES.....	8
FCC PART 18.....	8
EC DECLARATION OF CONFORMITY.....	8
DIRECTIVE 2002/95/EC (RoHS).....	9
DIRECTIVE 2002/96/EC (WEEE).....	9
AC POWER SUPPLY REGULATORY NOTES.....	10
INSTALLATION.....	11
VISUAL CHECK.....	11
POWER RATINGS.....	11
CONNECTION TO THE POWER SUPPLY.....	11
PROTECTION FROM ELECTRIC SHOCK.....	12
ENVIRONMENTAL CONDITIONS.....	13
FUSES.....	14
AC FUSE REPLACEMENT.....	14
DC FUSE REPLACEMENT.....	15
FUSE RATINGS.....	15
FRONT PANEL CONTROLS.....	16
REAR PANEL CONTROLS.....	19
GENERAL INFORMATION.....	21
BASIC TEST ARRANGEMENT.....	21
BASIC PULSE CONTROL.....	21
AMPLITUDE INTERACTION.....	22
POLARITY INVERSION.....	22
-DPP AND -DPN OPTIONS.....	23
MINIMIZING WAVEFORM DISTORTIONS.....	24
USE 50Ω TRANSMISSION LINES AND LOADS.....	24
USE LOW-INDUCTANCE LOADS.....	24

PREVENTING DAMAGE.....	24
MECHANICAL INFORMATION.....	25
TOP COVER REMOVAL.....	25
RACK MOUNTING.....	25
ELECTROMAGNETIC INTERFERENCE.....	25
MAINTENANCE.....	26
REGULAR MAINTENANCE.....	26
CLEANING.....	26
WIRING DIAGRAMS.....	27
WIRING OF AC POWER.....	27
PCB 158Q - LOW VOLTAGE POWER SUPPLY, 1/3.....	28
PCB 158Q - LOW VOLTAGE POWER SUPPLY, 2/3.....	29
PCB 158Q - LOW VOLTAGE POWER SUPPLY, 3/3.....	30
PCB 235B - HIGH VOLTAGE DC POWER SUPPLY.....	31
PCB 126C - OSCILLATOR AND TRIGGER CIRCUIT.....	32
MAIN WIRING.....	33
MAIN WIRING - AVP-AV-HV3-C-AC03-DPP-M-MITA.....	34
PERFORMANCE CHECK SHEET.....	35

Manual Reference: /files/server1/officefiles/instructword/avp/AVP-AV-HV3-C, edition 12.odt.
 Last modified February 29, 2024.
 Copyright © 2024 Avtech Electrosystems Ltd, All Rights Reserved.

INTRODUCTION

The AVP-AV-HV3-C is a high performance instrument capable of generating up to 40V into 50 Ω loads at repetition rates up to 1 MHz. The rise time is less than 150 ps, and the fall time is less than 600 ps. The pulse width is variable from 0.4 to 2 ns (or 4 ns, with the -W4 option).

Instruments with the "-P" model suffix can generate up to +40V, whereas instruments with the "-N" model suffix can generate up to -40V.

Instruments with the "-P-PN" suffix generate up to +40V at the main output, and are supplied with an inverting transformer that can be installed on the output to generate a negative signal.

Instruments with the "-N-PN" suffix generate up to -40V at the main output, and are supplied with an inverting transformer that can be installed on the output to generate a positive signal.

Instruments with the "-DPP" or "-DPN" options can generate pulse doublets with variable doublet spacing. The maximum output amplitude for these units is reduced by 30% compared to standard units (i.e., to 28V) due to the use of an internal pulse combiner. The two pulses in the doublet can be delayed relative to each other over a -5 to +5 ns range (or -500 to +500 ns with the -MITA option).

Instruments with the "-2CHPP" option have two output connectors. Both can be enabled at the same time. Both generate positive output amplitudes. Each output has independent pulse width and amplitude controls. The two channels share a common trigger source, and have a variable delay separation of 0 to ± 50 ns. Instruments with the "-2CHNN" option are similar, except that both outputs are negative. Instruments with the "-2CHPN" option have two outputs - one positive, and one negative.

The output is designed to drive 50 Ω loads. (A 50 Ω load is required for proper operation.) The output is AC-coupled.

This instrument is intended for use in research, development, test and calibration laboratories by qualified personnel.

AVAILABLE OPTIONS

The AVP-AV-HV3-C is available with several options:

-DPP Option: Double pulse waveform (both pulses in doublet are +). The two pulses in the doublet can be delayed relative to each other over a -5 to +5 ns range (or -500 to +500 ns with the -MITA option).

-DPN Option: Double pulse waveform (one pulse +, one pulse -). The two pulses in the doublet can be delayed relative to each other over a -5 to +5 ns range (or -500 to +500 ns with the -MITA option).

-EA Option: the output amplitude can be controlled by an externally generated 0 to +10V analog control voltage.

-EO Option: the output offset can be controlled by an externally generated 0 to +10V analog control voltage.

-EW Option: the output pulse width can be controlled by an externally generated 0 to +10V analog control voltage.

-M Option: a monitor output is provided.

-OS Option: an externally generated DC offset can be added to the output.

-OT Option: an internally generated DC offset, controlled by a front-panel dial, can be added to the output.

-2CHPP Option: Two active outputs (both positive).

-2CHPN Option: Two active outputs (one positive, one negative).

-2CHNN Option: Two active outputs (both negative).

SPECIFICATIONS

Model:	AVP-AV-HV3-C ¹
Maximum amplitude ^{3,4,8} : (50Ω load)	40 Volts ¹²
Pulse width (FWHM) ³ :	0.4 - 2 ns std. (0.4 - 4 ns opt ¹³)
PRF: external trigger mode:	0 Hz to 1 MHz
internal trigger:	100 Hz to 1 MHz
Rise time (20%-80%) ^{7,8} :	≤ 150 ps
Fall time (80%-20%) ^{7,8} :	≤ 600 ps
Polarity:	Specify -P, -N, -P-PN, or -N-PN (see note 6)
Dual-Polarity Option Style:	one output, with inverting transformer accessory.
Required load impedance:	50 Ohms ¹⁴
Two channel option:	Optional ⁷ .
Double pulse option:	Optional ⁹ .
Propagation delay:	≤ 70 ns (Ext trig in to pulse out)
Jitter, Ext trig in to pulse out:	±15 ps
Trigger modes:	Internal trigger, or external trigger (TTL level pulse, > 50 ns, 1 kΩ input impedance)
Variable delay:	0 to 200 ns, for internal trigger mode only. No variable delay in external trigger mode
Sync output (-B, -C unit only):	+3 Volts, > 50 ns, will drive 50 Ohm loads
DC offset or bias insertion:	Optional ¹⁰ . Apply required DC offset or bias in the range of ± 50V (250 mA max) to back panel solder terminal.
Monitor output option ¹¹ :	Provides a 20 dB (x10) attenuated coincident replica of main output
Connectors:	
OUT, MONITOR:	SMA
TRIG, SYNC:	BNC
Optional accessory kit: (attenuators and terminators)	Add the suffix "-AK1" to the model number to include the recommended accessory kit. Consists of three SMA, 18 GHz, 2 Watt attenuators (10, 20 & 30 dB) for use on the output, and two 50 Ohm, 1 GHz, 1 Watt feed-through terminators (one SMA, one BNC) for use on external trigger inputs.
Optional accessory kit: (coaxial cables and adapters)	Add the suffix "-AK8" to the model number to include the recommended accessory kit. Consists of one 12-inch SMA-M/SMA-M PE-SR405FL coaxial cable, one 12-inch SMA-M/SMA-M RG-316 coaxial cable, one 36-inch SMA-M/SMA-M RG-316 coaxial cable, one 24-inch SMA-M/BNC-M RG-316 coaxial cable, one 36-inch BNC-M/BNC-M RG58C/U coaxial cable, one SMA-F to BNC-M adapter, one SMA-M to BNC-F adapter, one SMA-F to SMA-F adapter, and one SMA-F to solder cup adapter
Temperature range:	+5°C to +40°C
Other:	
Power requirements:	100 - 240 Volts, 50 - 60 Hz
Dimensions:	100 × 430 × 375 mm (3.9" × 17" × 14.8")
Chassis material:	anodized aluminum, with blue plastic trim

- 1) -C suffix indicates stand-alone lab instrument with internal clock and line powering. No suffix indicates miniature module requiring DC power and external trigger. (See <http://www.avtechpulse.com/formats> for details of the four basic instrument formats).
- 2) -B suffix indicates IEEE-488.2 GPIB and RS-232 control of amplitude, pulse width, PRF and delay (See <http://www.avtechpulse.com/gpib>).
- 3) For analog electronic control (0 to +10V) of amplitude, pulse width or DC offset suffix model number with -EA or -EW or -EO. Electronic control units also include standard front-panel controls. -EW not available on -B units.
- 4) For operation at amplitudes of less than 20% of full-scale, best results will be obtained by setting the amplitude near full-scale and using external attenuators on the output.
- 5) For 20-500 ns pulse width, suffix model number with -W500. Rise times increase to 150 ps for -W500 units.
- 6) Indicate desired polarity by suffixing model number by -P or -N (i.e. positive or negative) or -P-PN or -N-PN for dual-polarity option where the suffix preceding -PN indicates the polarity at the mainframe output port.
- 7) For the two channel option, add the suffix -2CHPP for two positive outputs, the suffix -2CHNN for two negative outputs, or the suffix -2CHPN for the one positive output and one negative output.
- 8) For the double pulse option add the suffix -DPP for a unipolar output, and add the suffix -DPN for a bipolar output. These options cause the maximum amplitude to be reduced by 30%, and increase the rise and fall times by 50 ps.
- 9) Add the suffix -VXI to the model number to specify the Ethernet port.
- 10) For externally applied DC offset option suffix model number with -OS. The Avtech AVX-T bias tee can also be used to obtain DC offset. For internally generated DC offset option (0 to ±5V) add suffix -OT or -EO to model number. (The -OT option is controlled by a front-panel dial, whereas the -EO option can be controlled by a front-panel dial or by an external 0 to +10V voltage). -OT, -EO not available on modules.
- 11) For monitor option add suffix -M.
- 12) For positive output only. Maximum amplitude for negative output is 35V.
- 13) Typically < 100 ps at minimum pulse width. Increases at wider pulse widths.
- 14) A 50 Ohm load is required. Other loads may damage the instrument. Consult Avtech (info@avtechpulse.com) if you need to drive other load impedances.
- 15) For 0.4 - 4 ns pulse width, suffix model number with -W4.
- 16) For 0.3 - 4 ns pulse width, suffix model number with -W5.

REGULATORY NOTES

FCC PART 18

This device complies with part 18 of the FCC rules for non-consumer industrial, scientific and medical (ISM) equipment.

This instrument is enclosed in a rugged metal chassis and uses a filtered power entry module (where applicable). The main output signal is provided on a shielded connector that is intended to be used with shielded coaxial cabling and a shielded load. Under these conditions, the interference potential of this instrument is low.

If interference is observed, check that appropriate well-shielded cabling is used on the output connectors. Contact Avtech (info@avtechpulse.com) for advice if you are unsure of the most appropriate cabling. Also, check that your load is adequately shielded. It may be necessary to enclose the load in a metal enclosure.

If any of the connectors on the instrument are unused, they should be covered with shielded metal "dust caps" to reduce the interference potential.

This instrument does not normally require regular maintenance to minimize interference potential. However, if loose hardware or connectors are noted, they should be tightened. Contact Avtech (info@avtechpulse.com) if you require assistance.

EC DECLARATION OF CONFORMITY



We Avtech Electrosystems Ltd.
 P.O. Box 5120, LCD Merivale
 Ottawa, Ontario
 Canada K2C 3H5

declare that this pulse generator meets the intent of Directive 2004/108/EG for Electromagnetic Compatibility. Compliance pertains to the following specifications as listed in the official Journal of the European Communities:

EN 50081-1 Emission

EN 50082-1 Immunity

and that this pulse generator meets the intent of the Low Voltage Directive 72/23/EEC as amended by 93/68/EEC. Compliance pertains to the following specifications as listed in the official Journal of the European Communities:

EN 61010-1:2001 Safety requirements for electrical equipment for measurement, control, and laboratory use

DIRECTIVE 2002/95/EC (RoHS)

This instrument is exempt from Directive 2002/95/EC of the European Parliament and of the Council of 27 January 2003 on the Restriction of the use of certain Hazardous Substances (RoHS) in electrical and electronic equipment. Specifically, Avtech instruments are considered "Monitoring and control instruments" (Category 9) as defined in Annex 1A of Directive 2002/96/EC. The Directive 2002/95/EC only applies to Directive 2002/96/EC categories 1-7 and 10, as stated in the "Article 2 - Scope" section of Directive 2002/95/EC.

DIRECTIVE 2002/96/EC (WEEE)

European customers who have purchased this equipment directly from Avtech will have completed a "WEEE Responsibility Agreement" form, accepting responsibility for WEEE compliance (as mandated in Directive 2002/96/EC of the European Union and local laws) on behalf of the customer, as provided for under Article 9 of Directive 2002/96/EC.

Customers who have purchased Avtech equipment through local representatives should consult with the representative to determine who has responsibility for WEEE compliance. Normally, such responsibilities will lie with the representative, unless other arrangements (under Article 9) have been made.

Requirements for WEEE compliance may include registration of products with local governments, reporting of recycling activities to local governments, and financing of recycling activities.



AC POWER SUPPLY REGULATORY NOTES

This instrument converts the AC input power to the +24V DC voltage that powers the internal circuitry of this instrument using a Tamura AAD130SD-60-A switching power supply. According to the manufacturer, the Tamura AAD130SD-60-A has the following certifications:

UL60950-1
IEC60950 -1
CSA C22.2 No. 60950- 1
EN60950 -1

and is compliant with:

EN61000-3-2
EN61000-4-2 Level 2
EN61000-4-2 Level 3 (Air Only)
EN61000-4-4 Level 3
EN61000-4-5 Level 3
EN61000-4-11
CISPR 11 and 22 FCC Part 15 Class B (conducted)

INSTALLATION

VISUAL CHECK

After unpacking the instrument mainframe and the transformer module, examine to ensure that they have not been damaged in shipment. Visually inspect all connectors, knobs, and handles. Confirm that a power cord and an instrumentation manual (this manual), are with the instrument. If the instrument has been damaged, file a claim immediately with the company that transported the instrument.

POWER RATINGS

This instrument is intended to operate from 100 - 240 V, 50 - 60 Hz.

The maximum power consumption is 57 Watts. Please see the “FUSES” section for information about the appropriate AC and DC fuses.

This instrument is an “Installation Category II” instrument, intended for operation from a normal single-phase supply.

CONNECTION TO THE POWER SUPPLY

An IEC-320 three-pronged recessed male socket is provided on the back panel for AC power connection to the instrument. One end of the detachable power cord that is supplied with the instrument plugs into this socket. The other end of the detachable power cord plugs into the local mains supply. Use only the cable supplied with the instrument. The mains supply must be earthed, and the cord used to connect the instrument to the mains supply must provide an earth connection. (The supplied cord does this.)

 Warning: Failure to use a grounded outlet may result in injury or death due to electric shock. This product uses a power cord with a ground connection. It must be connected to a properly grounded outlet. The instrument chassis is connected to the ground wire in the power cord.

The table below describes the power cord that is normally supplied with this instrument, depending on the destination region:

Destination Region	Description	Option	Manufacturer	Part Number
United Kingdom, Hong Kong, Singapore, Malaysia	BS 1363, 230V, 50 Hz	-AC00	Qualtek	370001-E01
Australia, New Zealand	AS 3112:2000, 230-240V, 50 Hz	-AC01	Qualtek	374003-A01
Continental Europe, Korea, Indonesia, Russia	European CEE 7/7 "Schuko" 230V, 50 Hz	-AC02	Qualtek	364002-D01
North America, Taiwan	NEMA 5-15, 120V, 60 Hz	-AC03	Qualtek	312007-01
Switzerland	SEV 1011, 230V, 50 Hz	-AC06	Qualtek	378001-E01
South Africa, India	SABS 164-1, 220-250V, 50 Hz	-AC17	Volex	2131H 10 C3
Japan	JIS 8303, 100V, 50-60 Hz	-AC18	Qualtek	397002-01
Israel	SI 32, 220V, 50 Hz	-AC19	Qualtek	398001-01
China	GB 1002-1, 220V, 50 Hz	-AC22	Volex	2137H 10 C3

PROTECTION FROM ELECTRIC SHOCK

 Operators of this instrument must be protected from electric shock at all times. The owner must ensure that operators are prevented access and/or are insulated from every connection point. In some cases, connections must be exposed to potential human contact. Operators must be trained to protect themselves from the risk of electric shock. This instrument is intended for use by qualified personnel who recognize shock hazards and are familiar with safety precautions required to avoid possibly injury. In particular, operators should:

1. Keep exposed high-voltage wiring to an absolute minimum.
2. Wherever possible, use shielded connectors and cabling.
3. Connect and disconnect loads and cables only when the instrument is turned off.
4. Keep in mind that all cables, connectors, oscilloscope probes, and loads must have an appropriate voltage rating.
5. Do not attempt any repairs on the instrument, beyond the fuse replacement procedures described in this manual. Contact Avtech technical support (see page 2 for contact information) if the instrument requires servicing. Service is to be performed solely by qualified service personnel.

ENVIRONMENTAL CONDITIONS

This instrument is intended for use under the following conditions:

1. indoor use;
2. altitude up to 2 000 m;
3. temperature 5 °C to 40 °C;
4. maximum relative humidity 80 % for temperatures up to 31 °C decreasing linearly to 50 % relative humidity at 40 °C;
5. Mains supply voltage fluctuations up to ± 10 % of the nominal voltage;
6. no pollution or only dry, non-conductive pollution.

FUSES

This instrument contains four fuses. All are accessible from the rear-panel. Two protect the AC prime power input, and two protect the internal DC power supplies. The locations of the fuses on the rear panel are shown in the figure below:



AC FUSE REPLACEMENT

To physically access the AC fuses, the power cord must be detached from the rear panel of the instrument. The fuse drawer may then be extracted using a small flat-head screwdriver, as shown below:



DC FUSE REPLACEMENT

The DC fuses may be replaced by inserting the tip of a flat-head screwdriver into the fuse holder slot, and rotating the slot counter-clockwise. The fuse and its carrier will then pop out.

FUSE RATINGS

The following table lists the required fuses:

Fuses	Nominal Mains Voltage	Rating	Case Size	Recommended Replacement Part	
				Littelfuse Part Number	Digi-Key Stock Number
#1, #2 (AC)	100-240V	0.5A, 250V, Time-Delay	5×20 mm	0218.500HXP	F2416-ND
#3 (DC)	N/A	0.8A, 250V, Time-Delay	5×20 mm	0218.800HXP	F2418-ND
#4 (DC)	N/A	0.5A, 250V, Time-Delay	5×20 mm	0218.500HXP	F2416-ND

The recommended fuse manufacturer is Littelfuse (<http://www.littelfuse.com>).

Replacement fuses may be easily obtained from Digi-Key (<http://www.digikey.com>) and other distributors.

FRONT PANEL CONTROLS

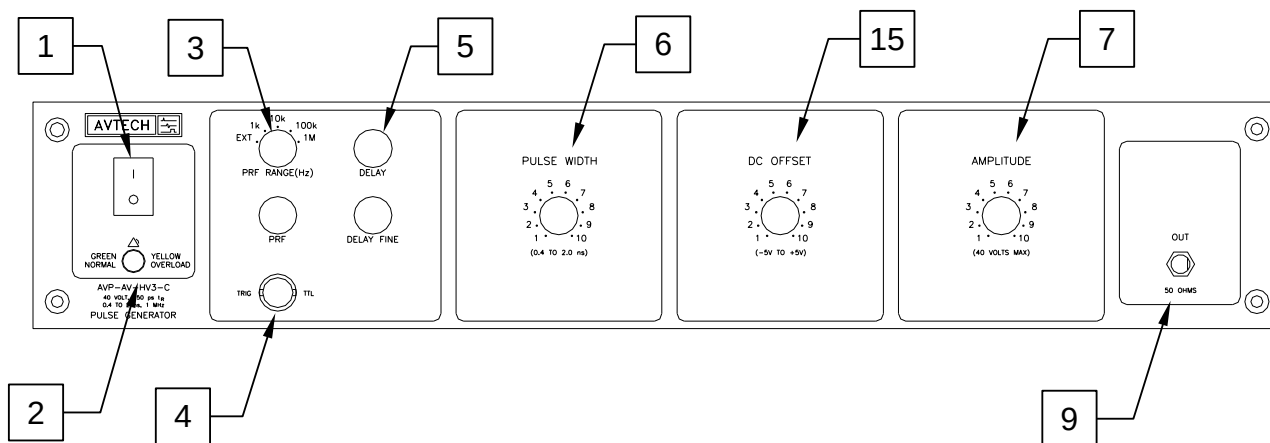

or

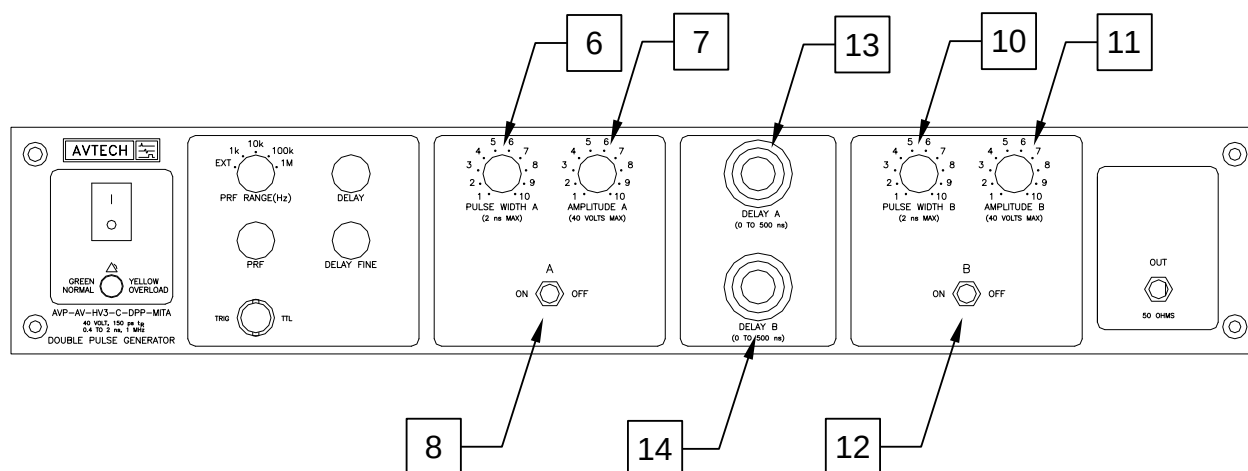

- 1) **POWER Switch**. This is the main power switch. When turning the instrument on, there may be a delay of several seconds before the instrument appears to respond.
- 2) **OVERLOAD Indicator**. When the instrument is powered, this indicator is normally green, indicating normal operation. If this indicator is yellow, an internal automatic overload protection circuit has been tripped. If the unit is overloaded (by operating at an exceedingly high duty cycle or by operating into a very low impedance), the protective circuit will disable the output of the instrument and turn the indicator light yellow. The light will stay yellow (i.e. output disabled) for about 5 seconds after which the instrument will attempt to re-enable the output (i.e. light green) for about 1 second. If the overload condition persists, the output will be disabled again (i.e.

light yellow) for another 5 seconds. If the overload condition has been removed, the instrument will resume normal operation.

This overload indicator may flash yellow briefly at start-up. This is not a cause for concern.

- 3) PRF Range Switch. This switch sets the pulse repetition frequency (PRF) range of the internal oscillator. The marked value of each position is the upper limit of the 10:1 range, approximately. The vernier dial directly below the switch varies the PRF within the set range.

If this switched is set to the “EXT” position, the instrument is triggered by a signal applied to the TRIG connector, rather than by the internal oscillator.

- 4) TRIG Connector. When the PRF Range Switch is set to “EXT”, the instrument is triggered by a TTL pulse applied to this connector. The pulse must be at least 50 ns wide.

When the PRF Range Switch is set to one of the four internal oscillator ranges, this connector is an output, which supplies a 2V, 200 ns wide pulse for each trigger event. This output may be used to trigger oscilloscopes or other equipment.

- 5) Delay Controls. When the PRF Range Switch is set to one of the four internal oscillator ranges, the main output is advanced or delayed relative to the TRIG output pulse (item 3). The delay is variable up to 200 ns, approximately, using the DELAY and DELAY FINE dials.
- 6) Pulse Width Control (A). This dial controls the pulse width of Output “A” (item 8).
- 7) Amplitude Control (A). This dial controls the amplitude of Output “A” (item 8).
- 8) Output On/Off (A). *Present on -DPP and -DPN units only*. This switch enables or disables the associated output.
- 9) OUT Connector. This SMA connector provides the main output. This output *requires* a 50Ω load to function properly.
- 10) Pulse Width Control (B). *Present on -DPP and -DPN units only*. This dial controls the pulse width of Output “B” (item 12).
- 11) Amplitude Control (B). *Present on -DPP and -DPN units only*. This dial controls the amplitude of Output “B” (item 12).
- 12) Output On/Off (B). *Present on -DPP and -DPN units only*. This switch enables or disables the associated output.

- 13) Delay A. *Present on -DPP-MITA units only*. The delays the A pulse by 0 to 500 ns, approximately.
- 14) Delay B. *Present on -DPP-MITA units only*. The delays the B pulse by 0 to 500 ns, approximately.
- 15) Offset Control. (Optional feature. Present on -EO and -OT units only). This dial controls the DC offset added to the output. The rear-panel OS ON/OFF switch must be set to "ON" to enable this function. On -EO units, the rear-panel OS INT/EXT switch must also be set to "INT".

REAR PANEL CONTROLS

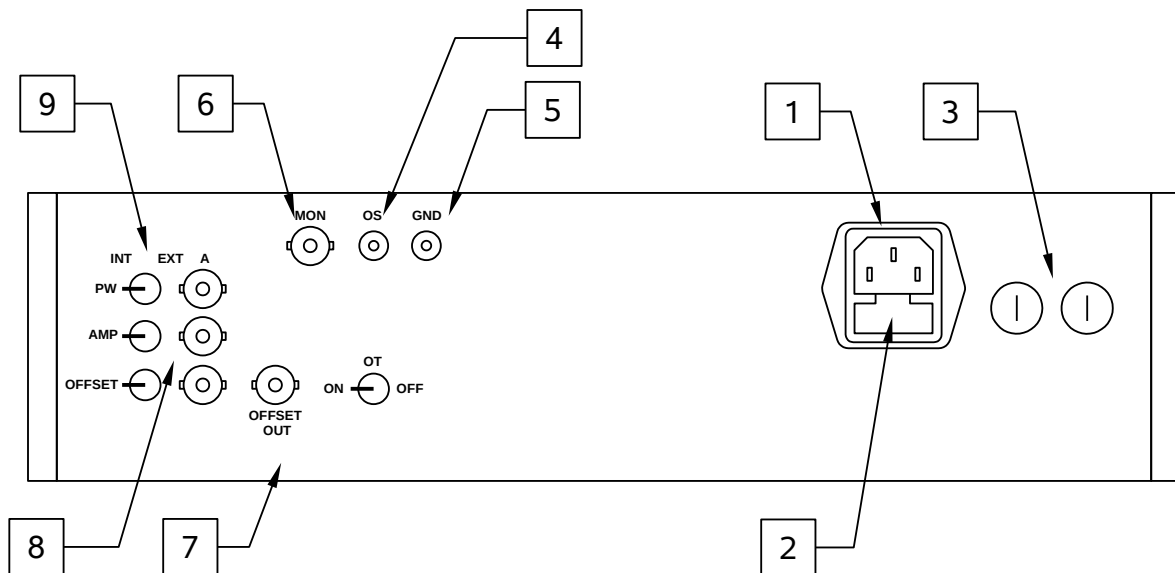

1. AC POWER INPUT. An IEC-320 C14 three-pronged recessed male socket is provided on the back panel for AC power connection to the instrument. One end of the detachable power cord that is supplied with the instrument plugs into this socket.
2. AC FUSE DRAWER. The two fuses that protect the AC input are located in this drawer. Please see the “FUSES” section of this manual for more information.
3. DC FUSES. These two fuses protect the internal DC power supplies. Please see the “FUSES” sections of this manual for more information.
4. OS INPUT CONNECTOR. (Present on units with -OS option only.) A DC offset in the range of $\pm 50\text{V}$ (250 mA max) may be applied to this solder terminal. The DC offset will appear on the output. When this feature is not used, the OS input should be connected to ground (using the adjacent GND connector). This is especially important when driving loads containing a diode.
5. GND CONNECTOR. (Present on units with -OS option only.) This solder terminal is connected to ground. It may be used to ground the OS input connector.
6. MON OUTPUT CONNECTOR. (Present on units with -M option only.) This SMA connector output provides a 20 dB attenuated coincident replica of main output, for monitoring purposes.
7. OFFSET ON/OFF SWITCH & OUTPUT. (Present on units with -EO or -OT options only). This switch enables the offset feature when it is set to “ON”. When it is set to “OFF”, no offset is added to the output. The internally generated offset is available at the “OFFSET OUT” BNC connector, for monitoring purposes. To add an offset to inverted pulses on units with the dual polarity option (-PN), connect this terminal to

the DC terminal of the inverting transformer (see the “POLARITY INVERSION” sections in this manual for further details).

8. AMP SWITCH & INPUT. (Present on units with -EA option only.) To control the output amplitude with an external voltage, set the rear-panel switch to the “EXT” position and apply 0 to +10V to the adjacent connector ($R_{IN} \geq 10k\Omega$).
9. PW SWITCH & INPUT. (Present on units with -EW option only.) To control the output pulse width with an external voltage, set the rear-panel switch to the “EXT” position and apply 0 to +10V to the adjacent connector ($R_{IN} \geq 10k\Omega$).

GENERAL INFORMATION

BASIC TEST ARRANGEMENT

The AVP-AV-HV3-C should be tested with a sampling oscilloscope with a bandwidth of at least 10 GHz to properly observe the high-speed waveform. (The cables and attenuators must also have a bandwidth of at least 10 GHz.) A typical test arrangement is shown below:

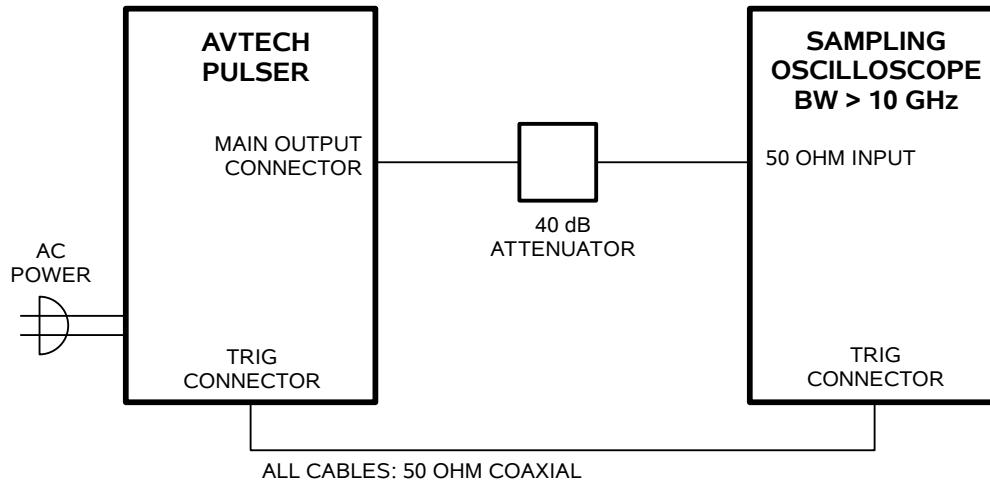

The attenuators are required to prevent damage to the sampling oscilloscope. A 40 dB attenuator with sufficient voltage rating should be used on the main output.

BASIC PULSE CONTROL

This instrument can be triggered by its own internal clock or by an external TTL trigger signal. When triggered internally, two mainframe output channels respond to the trigger: OUT and SYNC.

- OUT. This is the main output. The maximum output voltage is 40V for units without the -DPP or -DPN options.
- TRIG. The TRIG pulse is a fixed-width TTL-level reference pulse used to trigger oscilloscopes or other measurement systems.

The TRIG output precedes the main output. These pulses are illustrated below:

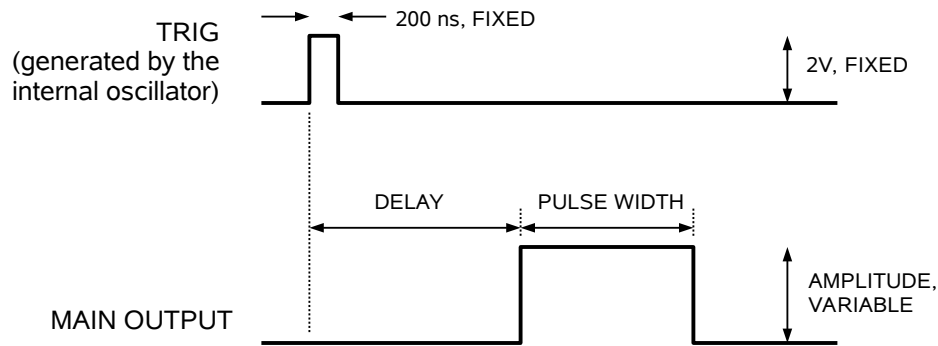

When triggered externally, the TRIG connector acts as an input. The delay controls do not function in this mode. This illustrated below:

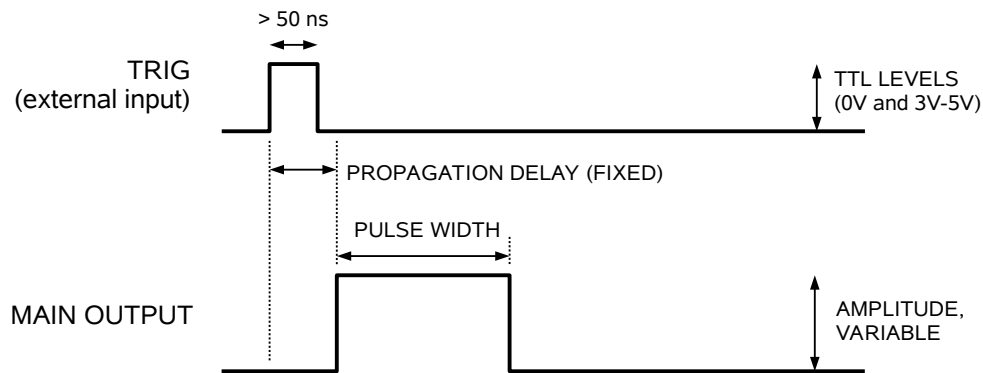

AMPLITUDE INTERACTION

Some properties of the output pulse may change as a function of the amplitude setting. For some demanding applications, it may be desirable to use a combination of external attenuators and the amplitude pot to achieve the desired output amplitude.

POLARITY INVERSION

Instruments with the "-P-PN" suffix generate up to +40V at the main output, and are supplied with an inverting transformer that can be installed on the mainframe output. A negative pulse is then obtained at the out port of the transformer module.

Instruments with the "-N-PN" suffix generate up to -40V at the main output, and are supplied with an inverting transformer that can be installed on the mainframe output. A positive pulse is then obtained at the out port of the transformer module.

When using the transformer with dual-polarity models with the "-OS" option, the external offset must be added to the DC terminal of the inverting transformer. Do not apply the offset to the rear-panel offset terminal on the mainframe (if present).

-DPP AND -DPN OPTIONS

Units with the -DPP or -DPN options can generate a pulse doublet in response to each trigger event. For internal triggering, the -DPP signals are related as shown below:

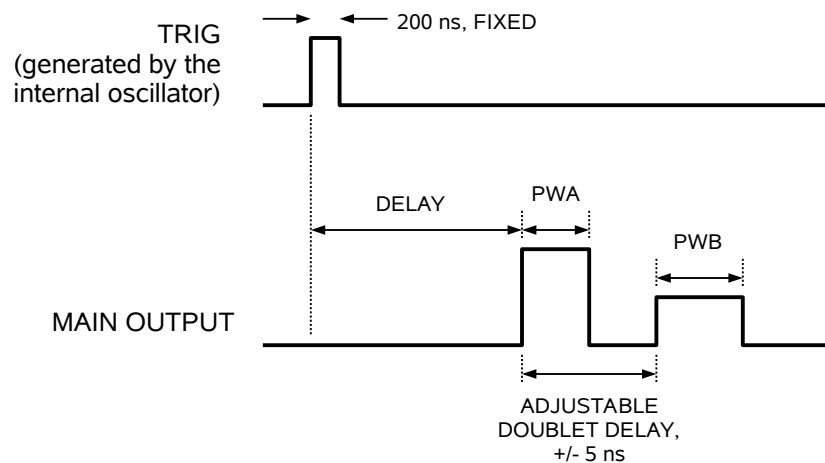

For the -DPN option, one of the pulses in the doublet is negative:

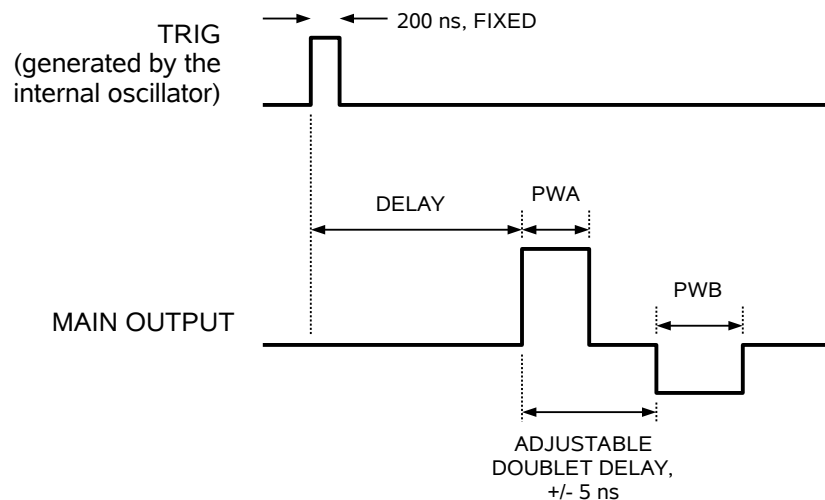

The “A” and “B” portions of the pulse doublet may be individually enabled or disabled.

Internally, the outputs of two pulse generators are summed in a pulse combiner. The individual pulse generators have a maximum output amplitude of 40V, but ~30% of this is lost in the pulse combiner, reducing the maximum output amplitude for a doublet to 28V, approximately.

It is safe to set the relative delay to zero to combine the two pulses into one higher-amplitude pulse.

MINIMIZING WAVEFORM DISTORTIONS

USE 50Ω TRANSMISSION LINES AND LOADS

Connect the load to the pulse generator with 50Ω transmission lines (e.g. RG-58 or RG-174 cable).

This instrument requires a 50Ω load for proper operation. It will not properly drive a high-impedance load. The output stage will be damaged if it is operated into an open circuit (or any other high impedance). Failures due to improper output loading are not covered by the warranty.

USE LOW-INDUCTANCE LOADS

Lenz's Law predicts that for an inductive voltage spike will be generated when the current through an inductance changes. Specifically, $V_{\text{SPIKE}} = L \times dI_{\text{LOAD}}/dt$, where L is the inductance, I_{LOAD} is the load current change, and t is time. For this reason, it is important to keep any parasitic in the load low. This means keeping wiring short, and using low inductance components. In particular, wire-wound resistors should be avoided.

PREVENTING DAMAGE

The AVP-AV-HV3-C may fail if triggered at a PRF greater than 1 MHz.

This unit is designed to operate into a load impedance of 50 Ohms and the output stage will be damaged if it is operated into an open circuit (or any other high impedance). Failures due to improper output loading are not covered by the warranty.

The lifetime of the switching elements in the pulse generator module is proportional to the running time of the instrument. For this reason the prime power to the instrument should be turned off when the instrument is not in use.

MECHANICAL INFORMATION

TOP COVER REMOVAL

If necessary, the interior of the instrument may be accessed by removing the four Phillips screws on the top panel. With the four screws removed, the top cover may be slid back (and off).

 Always disconnect the power cord and allow the instrument to sit unpowered for 10 minutes before opening the instrument. This will allow any internal stored charge to discharge.

There are no user-adjustable internal circuits. For repairs other than fuse replacement, please contact Avtech (info@avtechpulse.com) to arrange for the instrument to be returned to the factory for repair. Service is to be performed solely by qualified service personnel.

 Caution: High voltages are present inside the instrument during normal operation. Do not operate the instrument with the cover removed.

RACK MOUNTING

A rack mounting kit is available. The -R5 rack mount kit may be installed after first removing the one Phillips screw on the side panel adjacent to the front handle.

ELECTROMAGNETIC INTERFERENCE

To prevent electromagnetic interference with other equipment, all used outputs should be connected to shielded loads using shielded coaxial cables. Unused outputs should be terminated with shielded coaxial terminators or with shielded coaxial dust caps, to prevent unintentional electromagnetic radiation. All cords and cables should be less than 3m in length.

MAINTENANCE

REGULAR MAINTENANCE

This instrument does not require any regular maintenance.

On occasion, one or more of the four rear-panel fuses may require replacement. All fuses can be accessed from the rear panel. See the “FUSES” section for details.

CLEANING

If desired, the interior of the instrument may be cleaned using compressed air to dislodge any accumulated dust. (See the “TOP COVER REMOVAL” section for instructions on accessing the interior.) No other cleaning is recommended.

WIRING DIAGRAMS

WIRING OF AC POWER

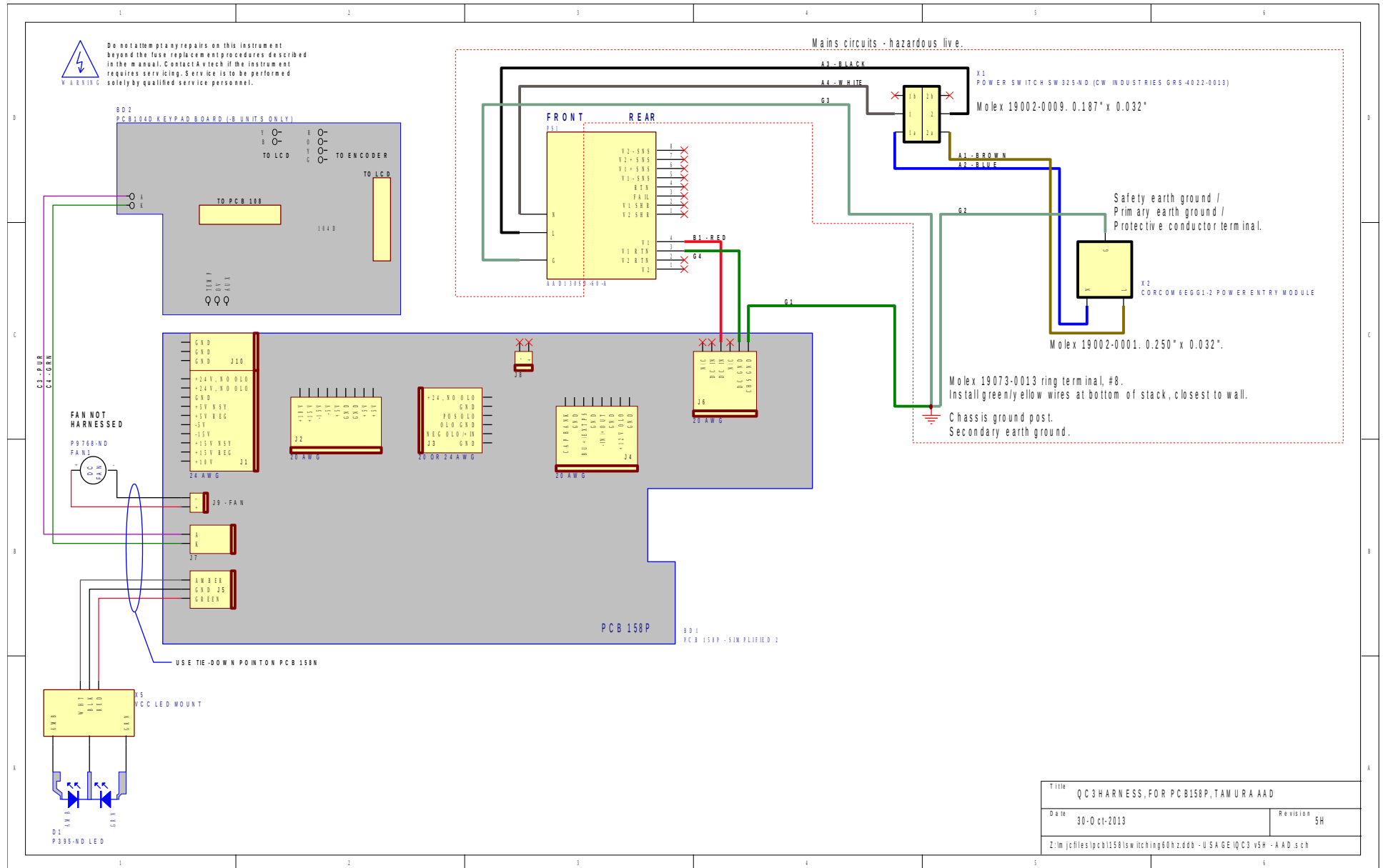

PCB 158Q - LOW VOLTAGE POWER SUPPLY, 1/3

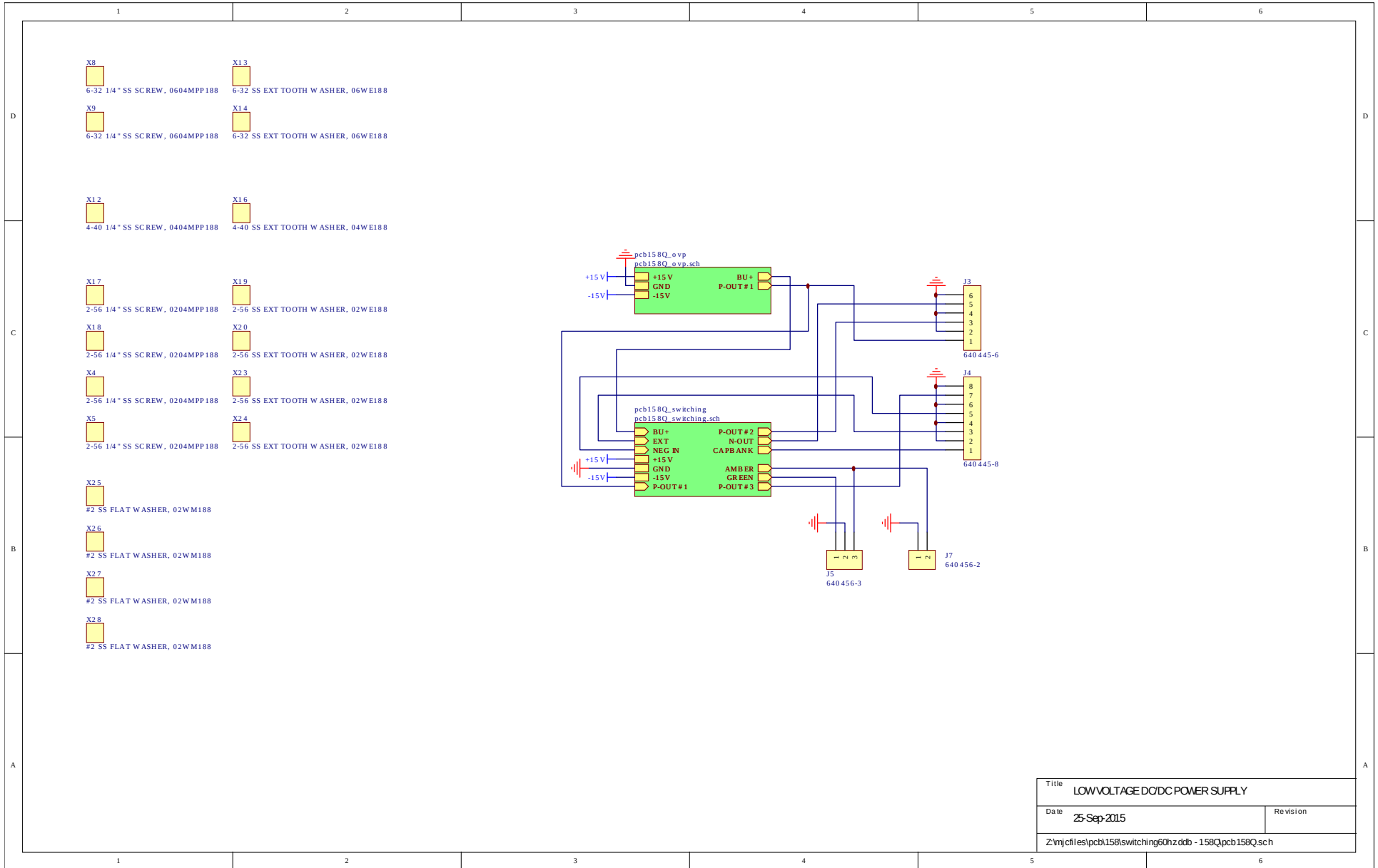

PCB 158Q - LOW VOLTAGE POWER SUPPLY, 2/3

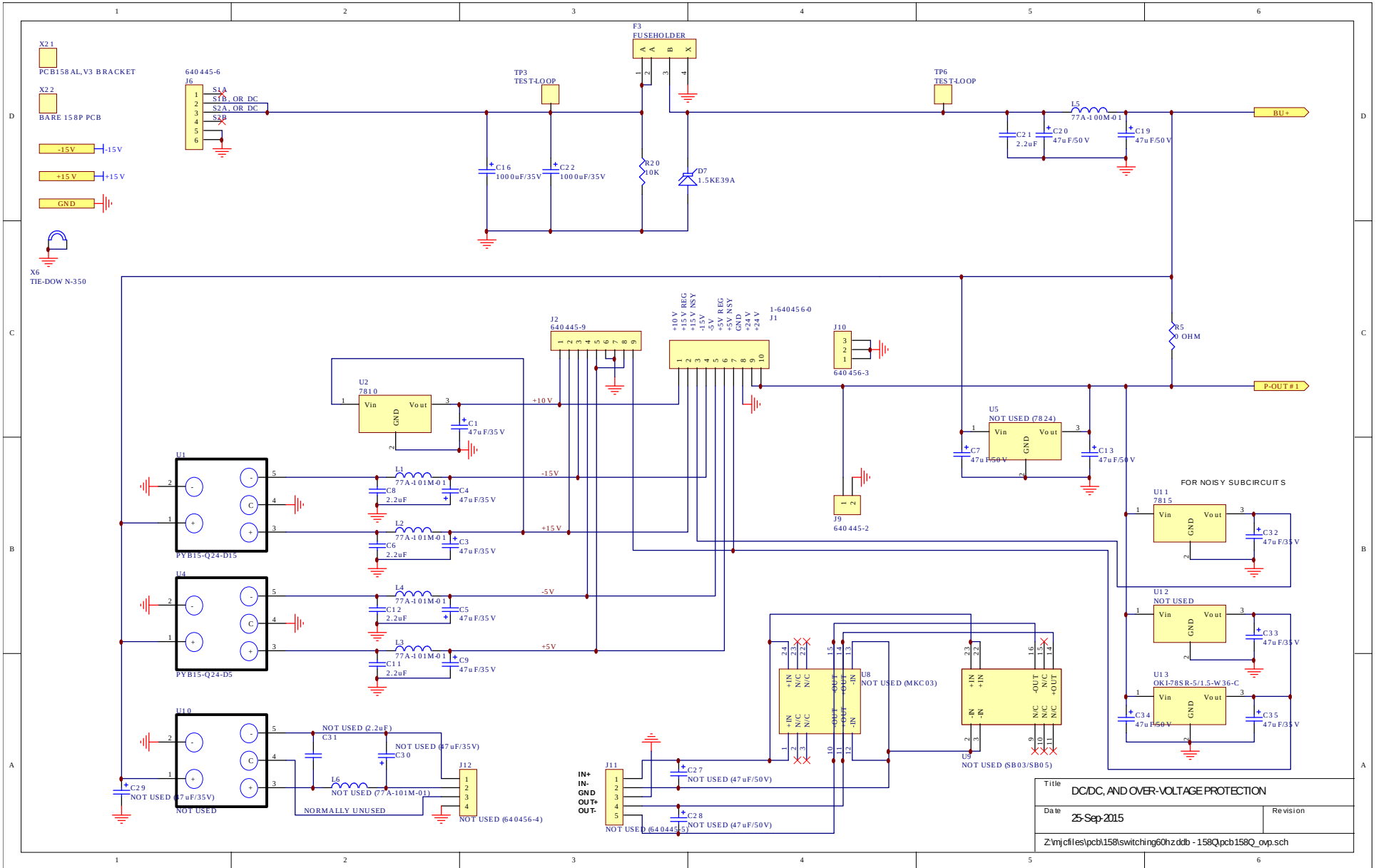

PCB 158Q - LOW VOLTAGE POWER SUPPLY, 3/3

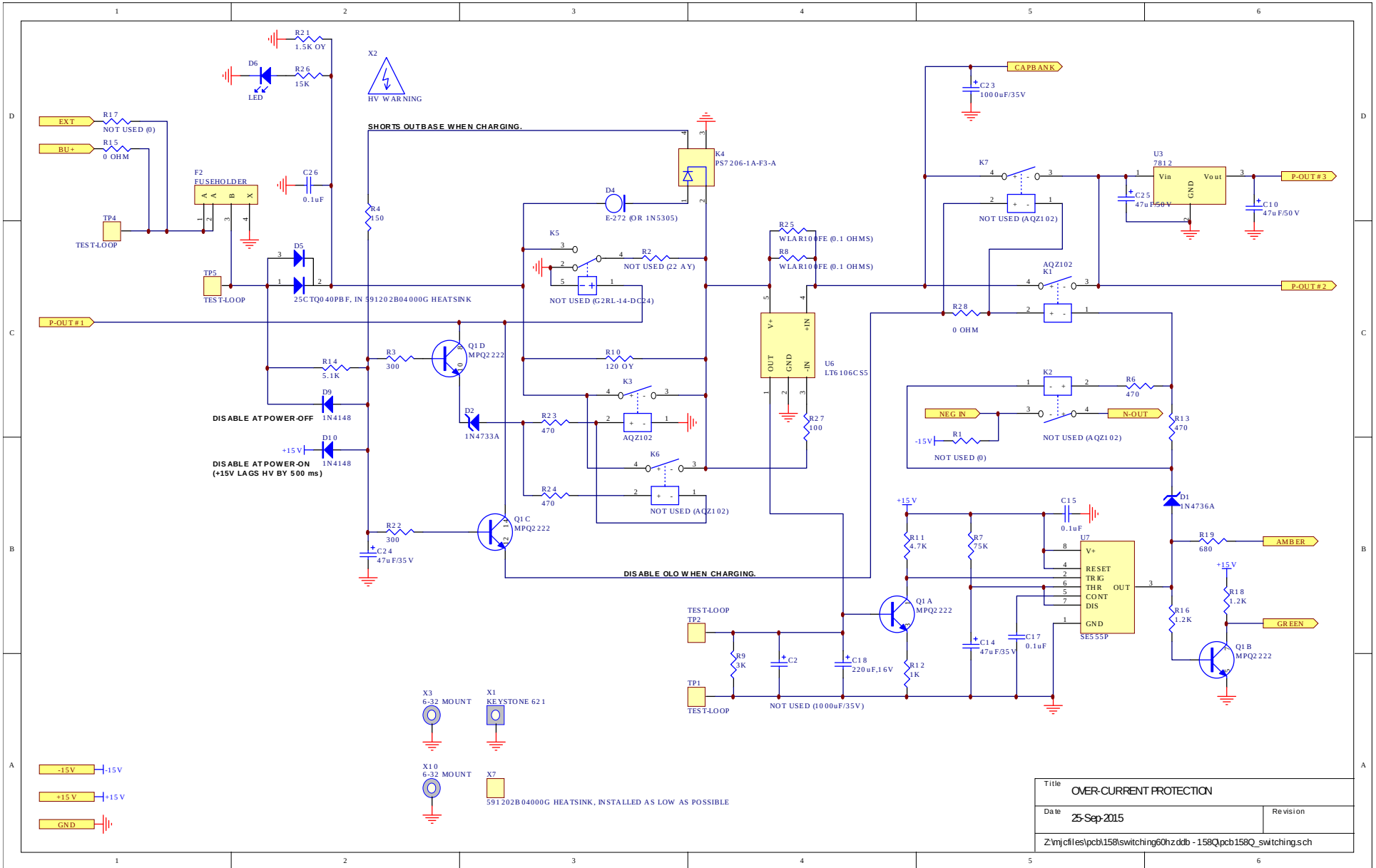

PCB 235B - HIGH VOLTAGE DC POWER SUPPLY

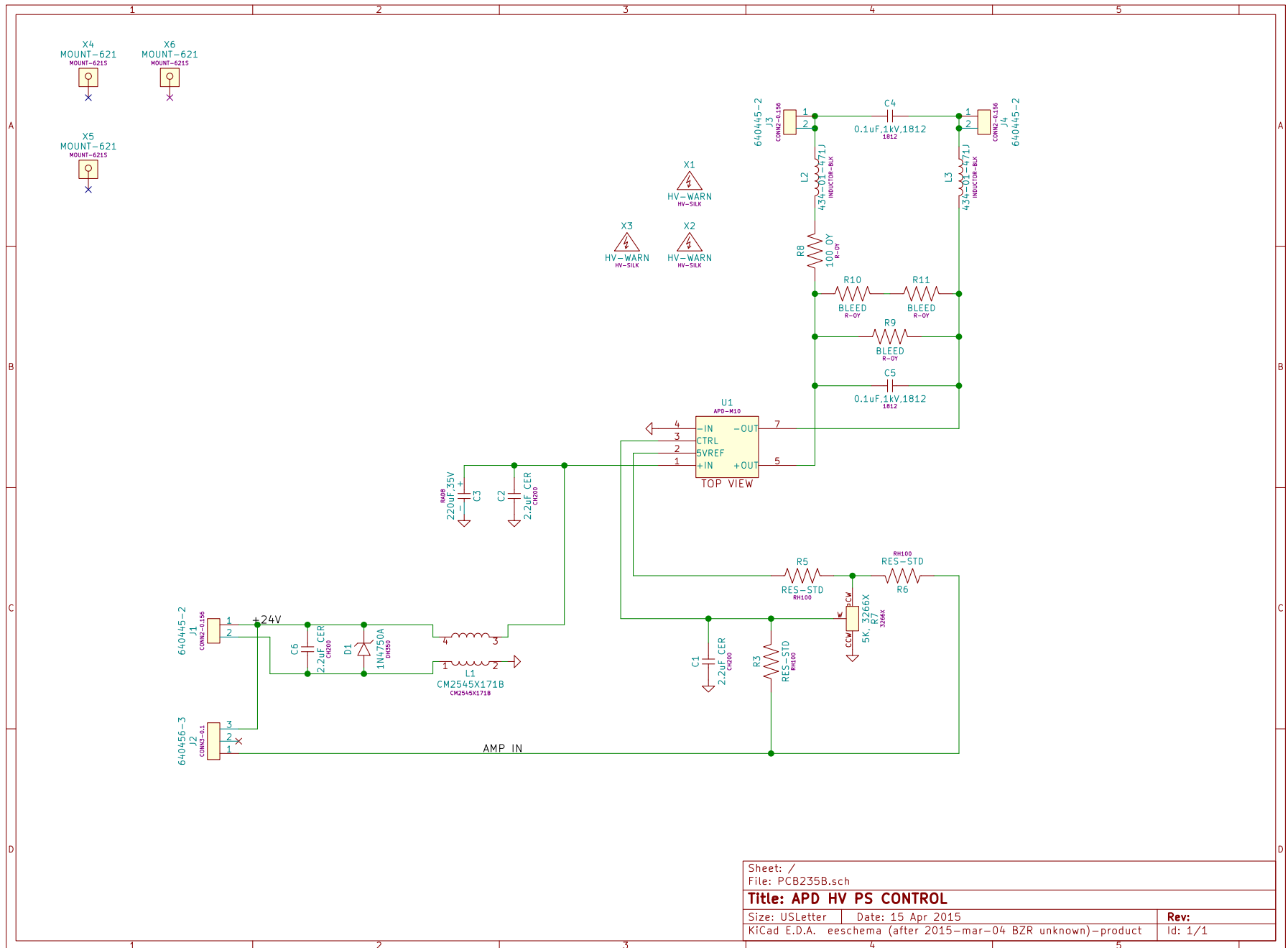

Sheet: /		File: PCB235B.sch	
Title: APD HV PS CONTROL			
Size: USLetter	Date: 15 Apr 2015	Rev:	
KiCad E.D.A. eeschema (after 2015-mar-04 BZR unknown)-product			Id: 1/1

PCB 126C - OSCILLATOR AND TRIGGER CIRCUIT

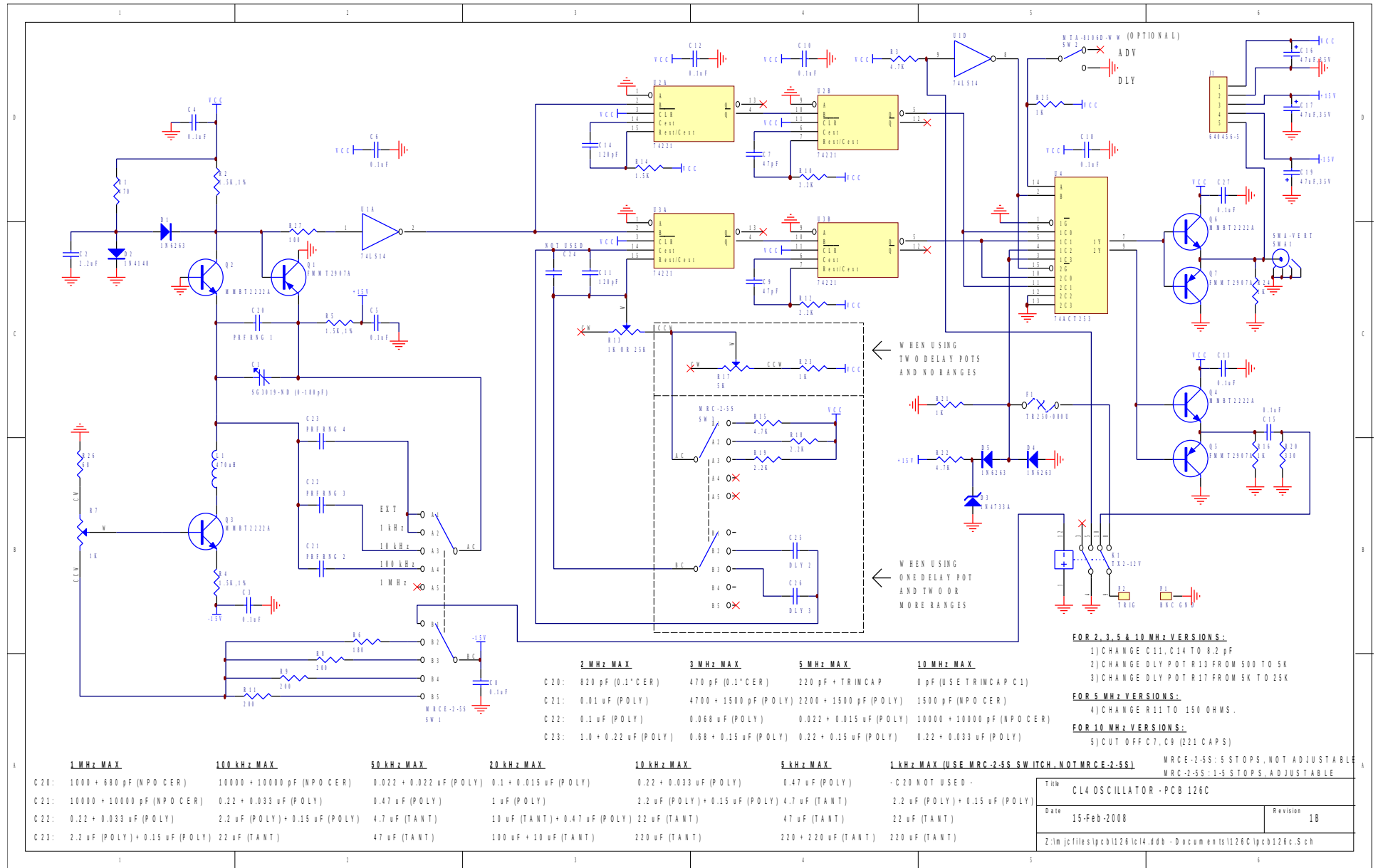

MAIN WIRING

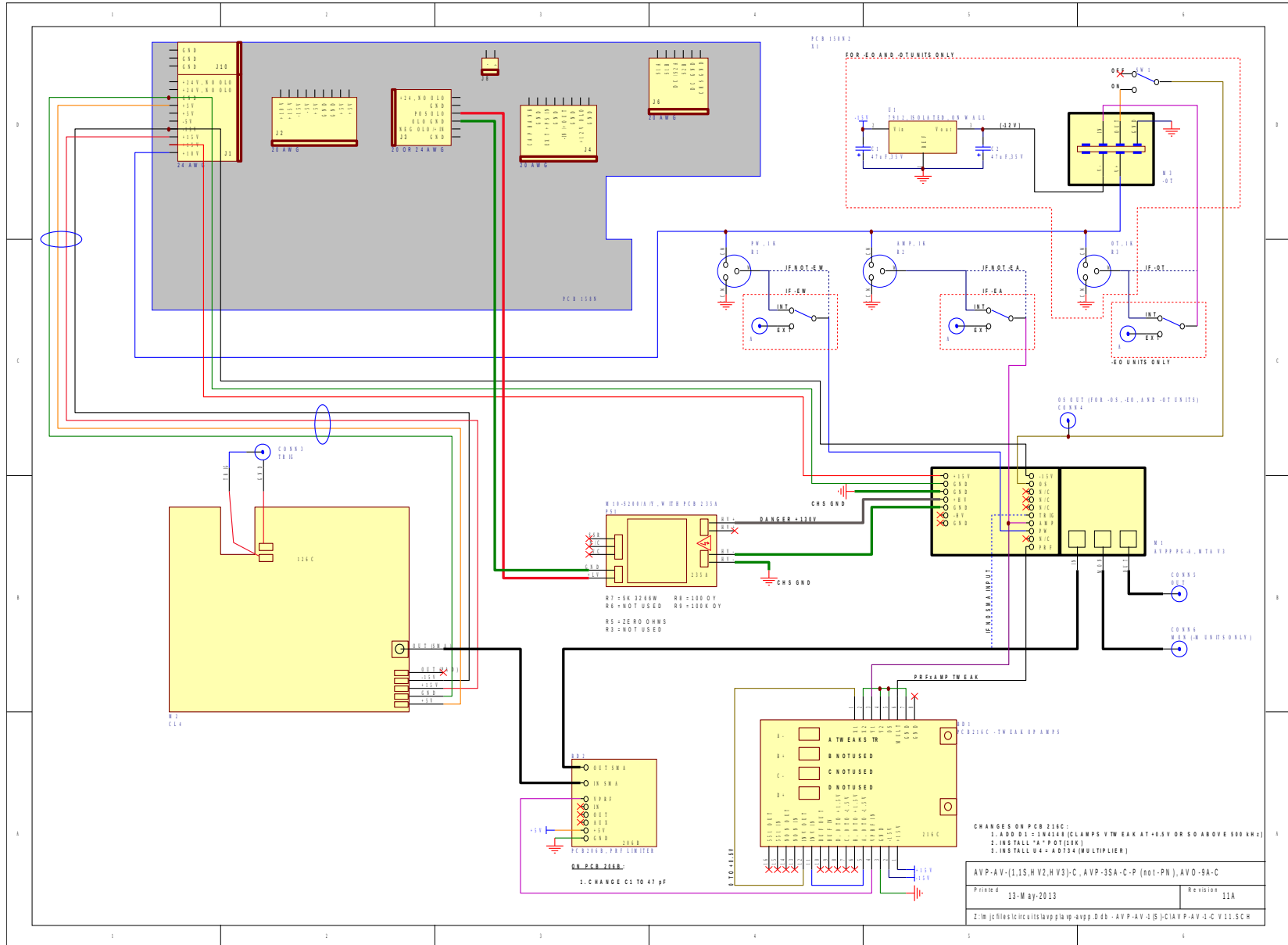

PERFORMANCE CHECK SHEET