

INSTRUCTIONS

MODEL AVP-AV-HV3-C-EA-EW-EO-ECL PULSE GENERATOR

S.N.:

WARRANTY

Avtech Electrosystems Ltd. warrants products of its manufacture to be free from defects in material and workmanship under conditions of normal use. If, within one year after delivery to the original owner, and after prepaid return by the original owner, this Avtech product is found to be defective, Avtech shall at its option repair or replace said defective item. This warranty does not apply to units which have been disassembled, modified or subjected to conditions exceeding the applicable specifications or ratings. This warranty is the extent of the obligation assumed by Avtech with respect to this product and no other warranty or guarantee is either expressed or implied.

TECHNICAL SUPPORT

Phone: 613-226-5772 or 1-800-265-6681

Fax: 613-226-2802 or 1-800-561-1970

E-mail: info@avtechpulse.com

World Wide Web: <http://www.avtechpulse.com>

TABLE OF CONTENTS

WARRANTY.....	2
TABLE OF CONTENTS.....	4
FIG. 1: PULSE GENERATOR TEST ARRANGEMENT.....	5
GENERAL OPERATING INSTRUCTIONS.....	6
FIG. 2 FRONT PANEL CONTROLS.....	8
FRONT PANEL CONTROLS.....	9
FIG. 3 BACK PANEL CONTROLS.....	10
BACK PANEL CONTROLS.....	11
TOP COVER REMOVAL.....	12
POWER SUPPLY AND FUSE REPLACEMENT.....	13
PERFORMANCE CHECK SHEET.....	15

FIG. 1: PULSE GENERATOR TEST ARRANGEMENT

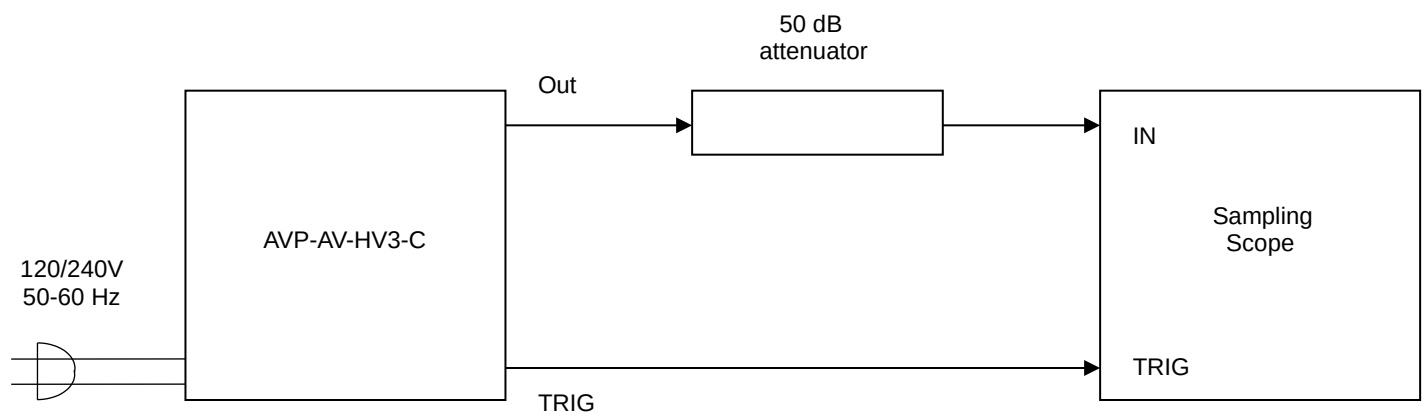

GENERAL OPERATING INSTRUCTIONS

- (1) The bandwidth capability of components and instruments used to display the pulse generator output signal (attenuators, cables, connectors, etc.) should exceed ten gigahertz.
- (2) The use of 50 dB attenuator at the sampling scope vertical input channel will insure a peak input signal to the sampling scope of less than one Volt.
- (3) The TRIG output channel provides TTL level signals.
- (4) To obtain a stable output display the PRF control on the front panel should be set mid-range while the PRF range switch may be in either range (but not in the EXT position) The front panel DELAY controls and the scope triggering controls are then adjusted to obtain a stable output. The scope may then be used to set the desired PRF by rotating the PRF control.
- (5) The output pulse width is controlled by means of the front panel one-turn PW control. The control should initially be set maximum clockwise and the pulse width adjusted using an oscilloscope.
- (6) To voltage control the output pulse width, set the rear panel switch in the EXT position and apply 0 to +10V to Connector A ($R_{IN} \geq 10K$). (EW option)
- (7) The output pulse amplitude is controlled by means of the front panel one-turn AMP control. The pulse width may change by several nanoseconds as the output amplitude is reduced from maximum to minimum. Therefore it is convenient to first set the desired amplitude and then set the desired pulse width. Rotation of the PW pot causes the position of the falling edge of the pulse to change.
- (8) Some properties of the output pulse may change as a function of the amplitude pot setting. For some demanding applications, it may be desirable to use a combination of external attenuators and the amplitude pot to achieve the desired output amplitude.
- (9) To voltage control the output amplitude set the rear panel switch in the EXT position and apply 0 +10V to Connector A ($R_{IN} \geq 10K$). (EA option)
- (10) To DC offset the output pulse connect a DC power supply set to the required DC offset value to the back panel terminals marked O.S. The maximum attainable DC offset voltage is ± 50 Volts. (Option).

- (11) To invert the output of the AVP unit, connect the AVX-2-T unit to the OUT port. An inverted pulse is then obtained at the OUT port of the AVX-2-T unit (-PN option). To DC offset the inverted pulse, the necessary DC offset potential must be applied to the DC solder terminal on the AVX-2-T module. Connecting the AVX-2-T module may result in a significant increase of the output pulse risetime. The low risetime may be restored by removing the top cover of the pulse generator chassis and placing the two-position P-PN switch in the PN position. The unit is shipped with this switch in the P position.
- (12) An external clock may be used to control the output PRF of the AVP unit by setting the front panel PRF range switch in the EXT position and applying a 50 ns (or wider) TTL level pulse to the TRIG BNC connector input. Note that the rear panel ECL-TTL switch must be in the TTL position.
- (13) The unit may be triggered externally using an ECL pulse by setting the front panel PRF range switch in the EXT position and setting the rear panel ECL-TTL switch in the ECL position. An ECL trigger pulse (≥ 50 ns) is then applied to the rear panel ECL-EXT TRIG BNC connector.
- (14) For units with the OT or EO options, the output DC offset is variable from +5 to -5 Volts by means of the front panel one-turn OFFSET control. The offset control may be turned off by means of the rear panel ON-OFF OFFSET switch.
- (15) For units with the EO option, the output offset may be voltage controlled by setting the rear panel switch in the EXT position and applying 0 to +10 Volts to Connector A ($R_{IN} \geq 10K$).
- (16) The unit can be converted from 120 to 240V 50-60 Hz operation by adjusting the voltage selector card in the rear panel fused voltage selector-cable connector assembly.
- (17) For additional assistance:
Tel: (613) 226-5772
Fax: (613) 226-2802
Email: info@avtechpulse.com

FIG. 2 FRONT PANEL CONTROLS

FRONT PANEL CONTROLS

- (1) ON-OFF Switch. Applies basic prime power to all stages.
- (2) PRF Control. With this range switch in the 1K, 10K, 100K or 1M positions, the PRF of the AVP unit is controlled via an internal clock, which in turn is controlled by the PRF controls. With the range switch in the EXT position, the AVP unit requires a 50 ns (or wider) TTL level pulse applied at the TRIG input in order to trigger the output stages. Note that the rear panel ECL-TTL switch must be in the TTL position. The unit may be triggered externally using an ECL pulse by setting the front panel PRF range switch in the EXT position and setting the rear panel ECL-TTL switch in the ECL position. AN ECL trigger pulse (≥ 50 ns) is then applied to the rear panel ECL-EXT TRIG BNC connector.
- (3) DELAY Controls. Controls the relative delay between the reference output pulse provided at the TRIG output (4) and the main output (5). This delay is variable over the range of 0 to at least 150 ns.
- (4) TRIG Output. When triggered internally, this output precedes the main output (5) and is used to trigger the scope time base. The output is a +3V 200 ns (approx) pulse capable of driving a fifty-Ohm load. Set scope to trigger on positive edge. The external trigger signal (TTL) is applied at this point when the PRF INT toggle switch is in the EXT position. For ECL triggering, see note (2)
- (5) PW Control. A one-turn control, which varies the output pulse width from 0 to 2 ns.
- (6) AMP Control. A one-turn control which varies the output pulse amplitude.
- (7) OUT. SMA connector provides output to 50 ohms.
- (8) OFFSET. For units with the OT offset option, the DC offset level is varied from 5 to +5V (to 50 Ohm) by the front panel OFFSET one-turn control. The DC offset may be turned off using the rear panel OS ON-OFF toggle switch (OT option).

FIG. 3 BACK PANEL CONTROLS

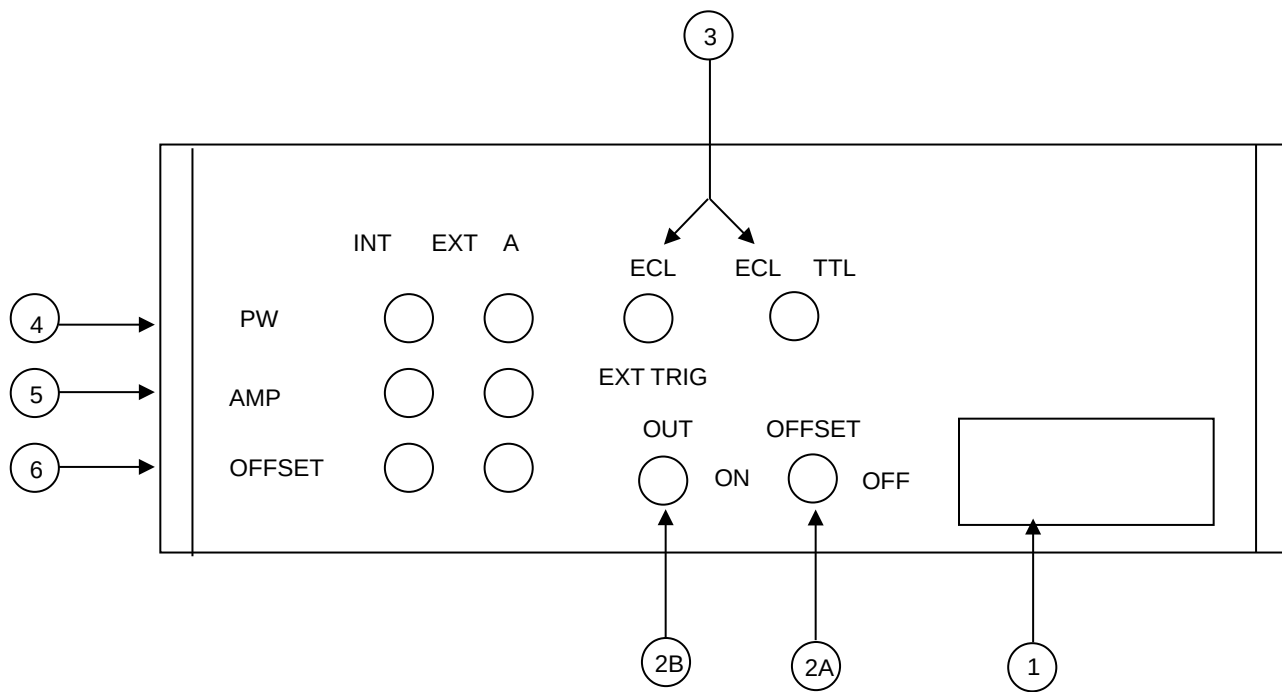

BACK PANEL CONTROLS

- (1) FUSED CONNECTOR, VOLTAGE SELECTOR. The detachable power cord is connected at this point. In addition, the removable cord is adjusted to select the desired input operating voltage. The unit also contains the main power fuse.

For AC line voltages of 110-120V, the power selector card should be installed so that the “120” marking is visible from the rear of the instrument.

For AC line voltages of 220-240V, the power selector card should be installed so that the “240” marking is visible from the rear of the instrument.

If it is not set for the proper voltage, remove the fuse and then grasp the card with a pair of pliers and remove it. Rotate horizontally through 180 degrees. Reinstall the card and the correct fuse.

In the 120V setting, a 0.5A slow blow fuse is required. In the 240V setting, a 0.25A slow blow fuse is required.

- (2A) OT. Two-position switch which turns output DC offset ON or OFF. (EO or OT options).
- (2B) OT. DC output offset potential appears at this terminal.
- (3) ECL-TTL Switch and ECL EXT TRIG BNC. The unit may be triggered externally using an ECL pulse by setting the front panel PRF range switch in the EXT position and setting the rear panel ECL-TTL switch in the ECL position. An ECL trigger pulse (≥ 50 ns) is then applied to the rear panel ECL-EXT TRIG BNC connector. To trigger externally with a TTL pulse, set the ECL-TTL switch in the TTL position and apply the TTL pulse to the front panel TRIG BNC.
- (4) PW. To voltage control the output pulse width, set the two-position switch in the EXT position and apply 0 to +10V to BNC Connector A ($R_{IN} \geq 10K$). (EW option).
- (5) AMP. To voltage control the output amplitude, set the two-position switch in the EXT position and apply 0 to +10V to BNC Connector A ($R_{IN} \geq 10K$). (EA option).
- (6) OFFSET. To voltage control the DC offset, set the two-position switch in the EXT position and apply 0 to +10V to BNC Connector A ($R_{IN} \geq 10K$). (EO option). Note that the OT switch (2A) must be in the “ON” position.

TOP COVER REMOVAL

- 1) The top cover may be removed by removing the four Philips screws on the top and then sliding the cover back and off.

POWER SUPPLY AND FUSE REPLACEMENT

This instrument has three main fuses, plus two spares. One, which protects the AC input, is located in the rear-panel power entry module, as described in the “Rear Panel Controls” section of this manual. If the power appears to have failed, check the AC fuse first.

The other two fuses (plus two spares) are located on the internal DC power supply, as shown below:

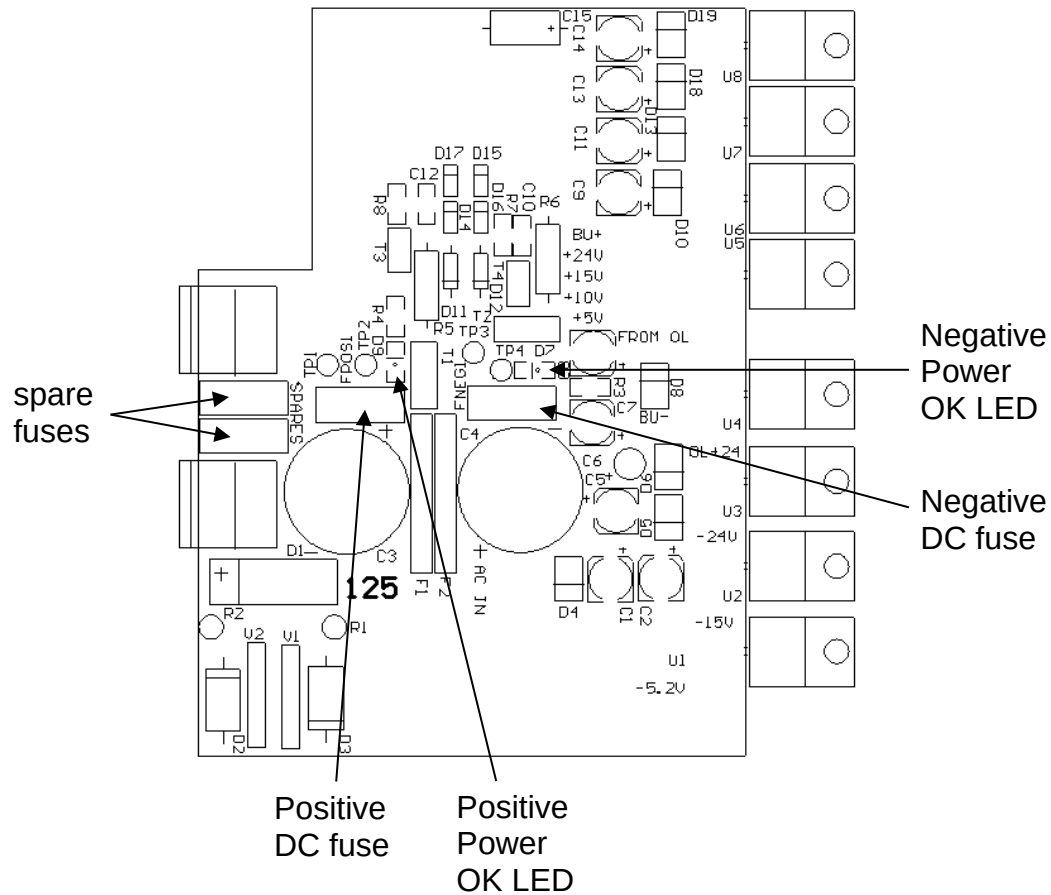

The positive fuse and one of the spare fuses on this circuit board are 1A slow-blow fuses, Littelfuse part number R452001. (This fuse can be ordered from Digikey, www.digikey.com. The Digikey part number is F1343CT-ND). The negative fuse and the second spare fuse are 0.5A slow-blow fuses (Littelfuse R452.500, Digikey part number F1341CT-ND).

If you suspect that the DC fuses are blown, follow this procedure:

1. Remove the top cover, by removing the four Phillips screws on the top cover and then sliding the cover back and off.
2. Locate the two "Power OK" LEDs on the power supply circuit board, as illustrated above.
3. Turn on the instrument.
4. Observe the "Power OK" LEDs. If the fuses are not blown, the two LEDs will be lit (bright red). If one of the LEDs is not lit, the fuse next to it has blown.
5. Turn off the instrument.
6. If a fuse is blown, use needle-nose pliers to remove the blown fuse from its surface-mount holder.
7. Replace the fuse. (Spare 1 Amp and 0.5 Amp fuses are provided on the circuit board. They may be transferred to the active fuse locations using needle-nose pliers.)

PERFORMANCE CHECK SHEET