



AVTECH ELECTROSYSTEMS LTD.

NANOSECOND WAVEFORM ELECTRONICS
SINCE 1975

P.O. BOX 265
OGDENSBURG, NY
U.S.A. 13669-0265
TEL: (315) 472-5270
FAX: (613) 226-2802

TEL: 1-800-265-6681
FAX: 1-800-561-1970

e-mail: info@avtechpulse.com
<http://www.avtechpulse.com/>

BOX 5120, LCD MERIVALE
OTTAWA, ONTARIO
CANADA K2C 3H4
TEL: (613) 226-5772
FAX: (613) 226-2802

INSTRUCTIONS

MODEL AVP-AVMP-2CHPP-UBB-C
0 TO +10 VOLTS, 1 MHz, DUAL CHANNEL
HIGH SPEED PULSE GENERATOR
WITH SUBNANOSECOND RISE & FALL TIMES

SERIAL NUMBER: _____

WARRANTY

Avtech Electrosystems Ltd. warrants products of its manufacture to be free from defects in material and workmanship under conditions of normal use. If, within one year after delivery to the original owner, and after prepaid return by the original owner, this Avtech product is found to be defective, Avtech shall at its option repair or replace said defective item. This warranty does not apply to units which have been disassembled, modified or subjected to conditions exceeding the applicable specifications or ratings. This warranty is the extent of the obligation assumed by Avtech with respect to this product and no other warranty or guarantee is either expressed or implied.

TECHNICAL SUPPORT

Phone: 613-226-5772 or 1-800-265-6681

Fax: 613-226-2802 or 1-800-561-1970

E-mail: info@avtechpulse.com

World Wide Web: <http://www.avtechpulse.com>

TABLE OF CONTENTS

WARRANTY.....	2
TECHNICAL SUPPORT.....	2
TABLE OF CONTENTS.....	3
INTRODUCTION.....	5
ORIGINAL QUOTATION.....	6
EUROPEAN REGULATORY NOTES.....	9
EC DECLARATION OF CONFORMITY.....	9
DIRECTIVE 2002/95/EC (RoHS).....	9
INSTALLATION.....	10
VISUAL CHECK.....	10
POWER RATINGS.....	10
CONNECTION TO THE POWER SUPPLY.....	10
PROTECTION FROM ELECTRIC SHOCK.....	11
ENVIRONMENTAL CONDITIONS.....	11
FUSES.....	13
AC FUSE REPLACEMENT.....	13
DC FUSE REPLACEMENT.....	14
FUSE RATINGS.....	14
FRONT PANEL CONTROLS.....	15
REAR PANEL CONTROLS.....	17
GENERAL INFORMATION.....	18
BASIC TEST ARRANGEMENT.....	18
BASIC PULSE CONTROL.....	18
AMPLITUDE INTERACTION.....	19
MINIMIZING WAVEFORM DISTORTIONS.....	20
USE 50Ω TRANSMISSION LINES AND LOADS.....	20
USE LOW-INDUCTANCE LOADS.....	20
PREVENTING DAMAGE.....	20
MECHANICAL INFORMATION.....	21
TOP COVER REMOVAL.....	21
RACK MOUNTING.....	21
ELECTROMAGNETIC INTERFERENCE.....	21
MAINTENANCE.....	22

REGULAR MAINTENANCE.....	22
CLEANING.....	22
WIRING DIAGRAMS.....	23
WIRING OF AC POWER.....	23
PCB 158K - LOW VOLTAGE POWER SUPPLY, 1/3.....	24
PCB 158K - LOW VOLTAGE POWER SUPPLY, 2/3.....	25
PCB 158K - LOW VOLTAGE POWER SUPPLY, 3/3.....	26
PCB 168B - HIGH VOLTAGE DC POWER SUPPLY.....	27
PCB 126B - OSCILLATOR AND TRIGGER CIRCUIT.....	28
MAIN WIRING - POSITIVE UNITS.....	29
PERFORMANCE CHECK SHEET.....	30

Manual Reference: /fileservers1/officefiles/instructword/avp/AVP-AVMP-2CHPP-UBB-C,ed1.odt.

Last modified February 29, 2024.

Copyright © 2024 Avtech Electrosystems Ltd, All Rights Reserved.

INTRODUCTION

The AVP-AVMP-2CHPP-UBB-C is a high performance instrument capable of generating up to +10V into 50Ω loads at repetition rates up to 1 MHz.

Two outputs (OUT A and OUT B) are provided. The amplitudes and pulse widths of the two outputs are independently variable. The relative delay between the two outputs is adjustable over a ±10 ns range. Each output is designed to drive 50Ω loads. (A 50Ω load is required for proper operation.) Each output is AC-coupled.

OUT A has a pulse width variable from 0.2 to 4 ns. The rise time is < 100 ps, and the fall time is < 135 ps.

OUT B has a pulse width variable from 7 ns to 1 us. The duty cycle can not exceed 5%. The rise time is < 200 ps, and the fall time is < 300 ps.

This instrument is intended for use in research and development laboratories.

ORIGINAL QUOTATION

Date: Mon, 26 Sep 2005 15:12:01 -0400
From: Avtech Sales

To: Jonathan Bird
Subject: Re: Double-Pulse Generators
Sept. 26, 2005
Jonathan Bird, Professor
Department of Electrical Engineering
332 Bonner Hall (Mailing Address)
201 Bonner Hall (Office Address)
University at Buffalo
The State University of New York
Buffalo, NY 14260-1900
Phone: (716) 645-3115 x1140
Fax: (716) 645-3656
jbird@buffalo.edu

John,

We have received an order from Japan and we thank you for your recommendation. In reply to your question concerning increasing the pulse width range for one of the channels, we are pleased to quote as follows:

Quote number: 12766.01

Model number: AVP-AVMP-2CHPP-UBA

Description: Two-Channel Ultra-High-Speed Pulse Generator

Output waveform: Two separate outputs, with separate amplitude and pulse width controls for the two pulses. The pulse separation is adjustable.

Pulse width: Output 1: 0.2 to 4 ns, adjustable. One-turn control.
Output 2: 5 to 100 ns, adjustable. One-turn control.

Amplitude: Output 1: 0 to +10V, adjustable via a one-turn control.
Output 2: 0 to +10V, adjustable via a one turn control.

Rise times (20%-80%): < 100 ps (Both channels).

Fall times (80%-20%): < 135 ps (Both channels).

Pulse repetition frequency (PRF): 100 Hz to 1 MHz, adjustable using a four-position decade range switch and a one-turn fine control.

Pulse separation: 0 to ± 10 ns, adjustable. One-turn control which delays output 2 with respect to output 1.

Chassis size: 3.9" x 14.8" x 17"

Connectors: Out: SMA, Trig: BNC

Price: \$6249 US each, FOB destination (includes 5% academic discount).

Estimated delivery: 45-60 days after receipt of order (*excluding export permit delay).

Quote number: 12766.02

Model number: AVP-AVMP-2CHPP-UBB

Description: Two-Channel Ultra-High-Speed Pulse Generator

Output waveform: Two separate outputs, with separate amplitude and pulse width controls for the two pulses. The pulse separation is adjustable.

Pulse width: Output 1: 0.2 to 4 ns, adjustable. One-turn control.

Output 2: 7 ns to 1 us, adjustable. One-turn control.

Note that maximum duty cycle must not exceed 5%.

Amplitude: Output 1: 0 to +10V, adjustable via a one-turn control.

Output 2: 0 to +10V, adjustable via a one-turn control.

Rise times (20%-80%): Output 1: < 100 ps.

Output 2: <=200 ps.

Fall times (80%-20%): Output 1: <= 135 ps.

Output 2: <= 300 ps.

Pulse repetition frequency (PRF): 100 Hz to 1 MHz, adjustable using a four-position decade range switch and a one-turn fine control. Note that maximum duty cycle must not exceed 5%.

Pulse separation: 0 to ± 10 ns, adjustable. One-turn control which delays output 2 with respect to output 1.

Chassis size: 3.9" x 14.8" x 17"

Connectors: Out: SMA, Trig: BNC

Price: \$7398 US each, FOB destination (includes 5% academic discount).

Estimated delivery: 45-60 days after receipt of order (*excluding export permit delay).

*Export Permit: These instruments are very high performance pulse generators, which are considered to be "Nuclear-Related Dual-Use Goods" under government regulations. As such, an "End Use Statement" must be completed when ordering. The necessary form is attached (in PDF format). We will use the information in the completed form to apply for an export license from the Canadian government, which will take 1 to 6 weeks to

Please call or email me if I can be of further assistance.

Thank you for your interest in our products!

Regards,

Dr. Walter Chudobiak
Senior Engineer

WC:ql

--- Avtech Electrosystems Ltd. ----- since 1975 ---

PO Box 265	ph: 1-800-265-6681 or 613-226-5772	Box 5120
Ogdensburg	fax: 1-800-561-1970 or 613-226-2802	LCD Merivale
New York	email: info@avtechpulse.com	Ottawa, Ontario
USA 13669-0265	http://www.avtechpulse.com/	Canada K2C 3H4

Pulse Generators - Laser Diode Drivers - HV Amplifiers
Monocycle Generators - Impulse Generators - Pulse Amplifiers
Current Pulsers - Function Generators - Frequency Dividers - and more!

Free catalog & newsletter ~ <http://www.avtechpulse.com/request/>

Jonathan Bird wrote:

> Dear Walter

>

> Just to follow up after a long silence at my end, I want to reassure you
> that I am planning to order this item. In fact, while I was visiting the
> group of Prof. Ochiai in Japan I recommended the same item to him and I
> believe that he has now ordered it. At the moment, I am waiting to clarify
> the status of my grant and I expect to place an order in the next few weeks.

>

> In the meantime, I had been wondering about the possibility of making a
> modification to the specs. In particular, would it be possible to change one
> of the two pulse outputs to yield pulse lengths that can be tuned over much
> wider range? What I am thinking is that it would be useful to be able to
> vary the length of the second pulse from a few ns to a few hundred (say up
> to 500 or 1000) ns?

>

> Regards

>

> Jon

EUROPEAN REGULATORY NOTES

EC DECLARATION OF CONFORMITY

We

Avtech Electrosystems Ltd.
P.O. Box 5120, LCD Merivale
Ottawa, Ontario
Canada K2C 3H4

declare that this pulse generator meets the intent of Directive 89/336/EEC for Electromagnetic Compatibility. Compliance pertains to the following specifications as listed in the official Journal of the European Communities:

EN 50081-1 Emission

EN 50082-1 Immunity

and that this pulse generator meets the intent of the Low Voltage Directive 72/23/EEC as amended by 93/68/EEC. Compliance pertains to the following specifications as listed in the official Journal of the European Communities:

EN 61010-1:2001 Safety requirements for electrical equipment for measurement, control, and laboratory use



DIRECTIVE 2002/95/EC (RoHS)

This instrument is exempt from Directive 2002/95/EC of the European Parliament and of the Council of 27 January 2003 on the Restriction of the use of certain Hazardous Substances (RoHS) in electrical and electronic equipment. Specifically, Avtech instruments are considered "Monitoring and control instruments" (Category 9) as defined in Annex 1A of Directive 2002/96/EC. The Directive 2002/95/EC only applies to Directive 2002/96/EC categories 1-7 and 10, as stated in the "Article 2 - Scope" section of Directive 2002/95/EC.

INSTALLATION

VISUAL CHECK

After unpacking the instrument, examine it to ensure that it has not been damaged in shipment. Visually inspect all connectors, knobs, and handles. Confirm that a power cord and an instrumentation manual (this manual) are with the instrument. If the instrument has been damaged, file a claim immediately with the company that transported the instrument.

POWER RATINGS

This instrument is intended to operate from 100 - 240 V, 50 - 60 Hz.

The maximum power consumption is 57 Watts. Please see the “FUSES” section for information about the appropriate AC and DC fuses.

This instrument is an “Installation Category II” instrument, intended for operation from a normal single-phase supply.

CONNECTION TO THE POWER SUPPLY

An IEC-320 three-pronged recessed male socket is provided on the back panel for AC power connection to the instrument. One end of the detachable power cord that is supplied with the instrument plugs into this socket. The other end of the detachable power cord plugs into the local mains supply. Use only the cable supplied with the instrument. The mains supply must be earthed, and the cord used to connect the instrument to the mains supply must provide an earth connection. (The supplied cord does this.)

 Warning: Failure to use a grounded outlet may result in injury or death due to electric shock. This product uses a power cord with a ground connection. It must be connected to a properly grounded outlet. The instrument chassis is connected to the ground wire in the power cord.

The table below describes the power cord that is normally supplied with this instrument, depending on the destination region:

Destination Region	Description	Manufacturer	Part Number
Continental Europe	European CEE 7/7 "Schuko" 230V, 50Hz	Volex (http://www.volex.com)	17850-C3-326
		Qualtek (http://www.qualtekusa.com)	319004-T01
United Kingdom	BS 1363, 230V, 50Hz	Qualtek (http://www.qualtekusa.com)	370001-E01
Switzerland	SEV 1011, 2 30V, 50Hz	Volex (http://www.volex.com)	2102H-C3-10
Israel	SI 32, 220V, 50Hz	Volex (http://www.volex.com)	2115H-C3-10
North America, and all other areas	NEMA 5-15, 120V, 60 Hz	Qualtek (http://www.qualtekusa.com)	312007-01

PROTECTION FROM ELECTRIC SHOCK

 Operators of this instrument must be protected from electric shock at all times. The owner must ensure that operators are prevented access and/or are insulated from every connection point. In some cases, connections must be exposed to potential human contact. Operators must be trained to protect themselves from the risk of electric shock. This instrument is intended for use by qualified personnel who recognize shock hazards and are familiar with safety precautions required to avoid possibly injury. In particular, operators should:

1. Keep exposed high-voltage wiring to an absolute minimum.
2. Wherever possible, use shielded connectors and cabling.
3. Connect and disconnect loads and cables only when the instrument is turned off.
4. Keep in mind that all cables, connectors, oscilloscope probes, and loads must have an appropriate voltage rating.
5. Do not attempt any repairs on the instrument, beyond the fuse replacement procedures described in this manual. Contact Avtech technical support (see page 2 for contact information) if the instrument requires servicing. Service is to be performed solely by qualified service personnel.

ENVIRONMENTAL CONDITIONS

This instrument is intended for use under the following conditions:

- a) indoor use;
- b) altitude up to 2 000 m;
- c) temperature 5 °C to 40 °C;

- d) maximum relative humidity 80 % for temperatures up to 31 °C decreasing linearly to 50 % relative humidity at 40 °C;
- e) Mains supply voltage fluctuations up to ± 10 % of the nominal voltage;
- f) no pollution or only dry, non-conductive pollution.

FUSES

This instrument contains four fuses. All are accessible from the rear-panel. Two protect the AC prime power input, and two protect the internal DC power supplies. The locations of the fuses on the rear panel are shown in the figure below:



AC FUSE REPLACEMENT

To physically access the AC fuses, the power cord must be detached from the rear panel of the instrument. The fuse drawer may then be extracted using a small flat-head screwdriver, as shown below:



DC FUSE REPLACEMENT

The DC fuses may be replaced by inserting the tip of a flat-head screwdriver into the fuse holder slot, and rotating the slot counter-clockwise. The fuse and its carrier will then pop out.

FUSE RATINGS

The following table lists the required fuses:

Fuses	Nominal Mains Voltage	Rating	Case Size	Manufacturer's Part Number (Wickmann)	Distributor's Part Number (Digi-Key)
#1, #2 (AC)	100-240V	0.5A, 250V, Time-Delay	5×20 mm	1950500000	WK5041-ND
#3 (DC)	N/A	1.0A, 250V, Time-Delay	5×20 mm	1951100000	WK5048-ND
#4 (DC)	N/A	0.5A, 250V, Time-Delay	5×20 mm	1950500000	WK5041-ND

The fuse manufacturer is Wickmann (<http://www.wickmann.com/>).

Replacement fuses may be easily obtained from Digi-Key (<http://www.digikey.com/>) and other distributors.

FRONT PANEL CONTROLS

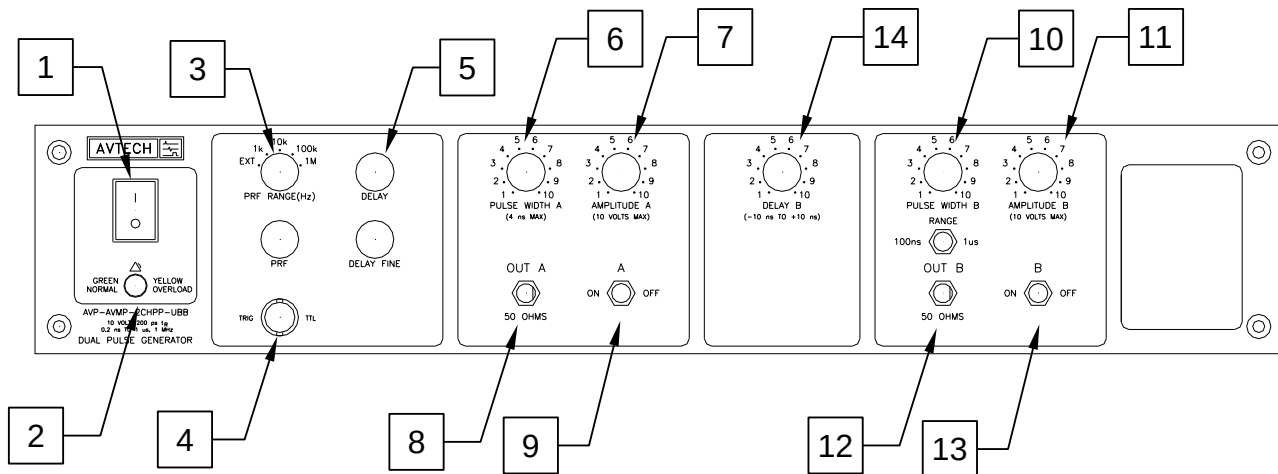

- 1) POWER Switch. This is the main power switch. When turning the instrument on, there may be a delay of several seconds before the instrument appears to respond.
- 2) OVERLOAD Indicator. When the instrument is powered, this indicator is normally green, indicating normal operation. If this indicator is yellow, an internal automatic overload protection circuit has been tripped. If the unit is overloaded (by operating at an exceedingly high duty cycle or by operating into a very low impedance), the protective circuit will disable the output of the instrument and turn the indicator light yellow. The light will stay yellow (i.e. output disabled) for about 5 seconds after which the instrument will attempt to re-enable the output (i.e. light green) for about 1 second. If the overload condition persists, the output will be disabled again (i.e. light yellow) for another 5 seconds. If the overload condition has been removed, the instrument will resume normal operation.

This overload indicator may flash yellow briefly at start-up. This is not a cause for concern.

- 3) PRF Range Switch. This switch sets the pulse repetition frequency (PRF) range of the internal oscillator. The marked value of each position is the upper limit of the 10:1 range, approximately. The vernier dial directly below the switch varies the PRF within the set range.

If this switched is set to the "EXT" position, the instrument is triggered by a signal applied to the TRIG connector, rather than by the internal oscillator.

- 4) TRIG Connector. When the PRF Range Switch is set to "EXT", the instrument is triggered by a TTL pulse applied to this connector. The pulse must be at least 50 ns wide.

When the PRF Range Switch is set to one of the four internal oscillator ranges, this

connector is an output, which supplies a 2V, 200 ns wide pulse for each trigger event. This output may be used to trigger oscilloscopes or other equipment.

- 5) Delay Controls. When the PRF Range Switch is set to one of the four internal oscillator ranges, the main output is advanced or delayed relative to the TRIG output pulse (item 3). The delay is variable up to 200 ns, approximately, using the DELAY and DELAY FINE dials.
- 6) Pulse Width A Control. This dial controls the pulse width of OUT A.
- 7) Amplitude A Control. This dial controls the amplitude of OUT A.
- 8) OUT A Connector. This SMA connector provides the OUT A signal. This output *requires* a 50 Ω load to function properly.
- 9) A ON/OFF Switch. This switch enables or disables OUT A. If the output is not being used, this switch should be set to "OFF".
- 10) Pulse Width B Control. This dial and range switch combination controls the pulse width of OUT B. The switch selects one of two ranges (7 ns to 100 ns, and 100 ns to 1 us). The dial varies the pulse width within the selected range.

When the PW B dial is set fully counter-clockwise, the pulse width may drift several nanoseconds until thermal equilibrium is reached internally (after five minutes approximately).

The maximum duty cycle rating is 5%, so the PRF range switch should be set to the 100 kHz range (or lower) when the PW B range switch is set in the 1 us position.

- 11) Amplitude B Control. This dial controls the amplitude of OUT B.
- 12) OUT B Connector. This SMA connector provides the OUT B signal. This output *requires* a 50 Ω load to function properly.
- 13) B ON/OFF Switch. This switch enables or disables OUT B. If the output is not being used, this switch should be set to "OFF".
- 14) DELAY B Control. This dial varies the relative delay between the A and B outputs, over a range of -10 ns to +10 ns.

REAR PANEL CONTROLS

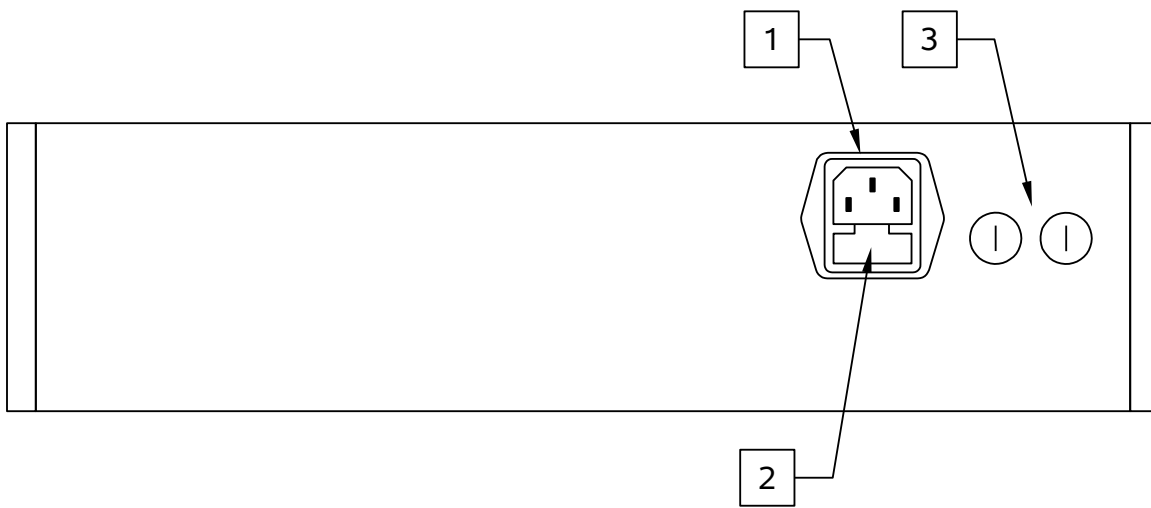

1. AC POWER INPUT. An IEC-320 C14 three-pronged recessed male socket is provided on the back panel for AC power connection to the instrument. One end of the detachable power cord that is supplied with the instrument plugs into this socket.
2. AC FUSE DRAWER. The two fuses that protect the AC input are located in this drawer. Please see the “FUSES” section of this manual for more information.
3. DC FUSES. These two fuses protect the internal DC power supplies. Please see the “FUSES” sections of this manual for more information.

GENERAL INFORMATION

BASIC TEST ARRANGEMENT

The AVP-AVMP-2CHPP-UBB-C should be tested with a sampling oscilloscope with a bandwidth of at least 10 GHz to properly observe the high-speed waveform. (The cables and attenuators must also have a bandwidth of at least 10 GHz.) A typical test arrangement is shown below:

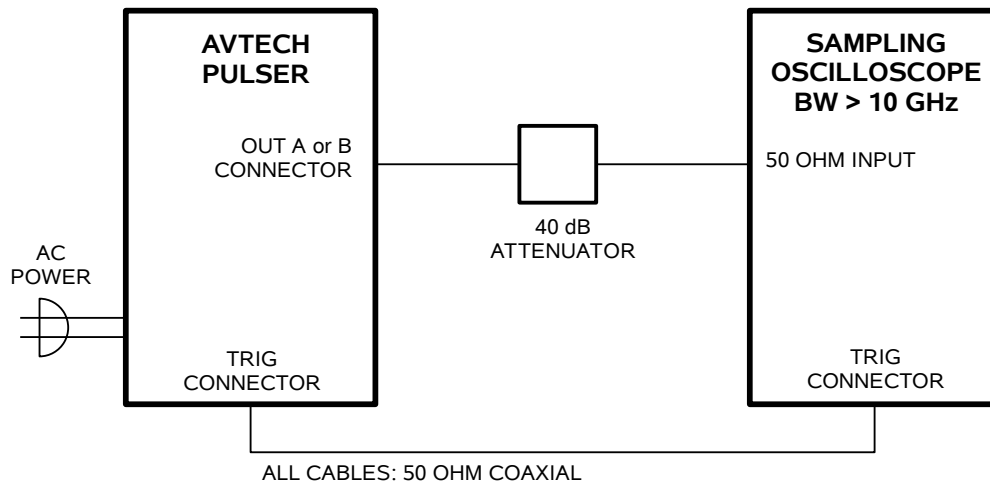

The attenuators are required to prevent damage to the sampling oscilloscope. A 40 dB attenuator with sufficient voltage rating should be used on the main output.

BASIC PULSE CONTROL

This instrument can be triggered by its own internal clock or by an external TTL trigger signal. When triggered internally, three mainframe output channels respond to the trigger: OUT A, OUT B, and TRIG.

- OUT A. This is one of the main outputs. The maximum output voltage is 10V.
- OUT B. This is the other main output. The maximum output voltage is 10V.
- TRIG. The TRIG pulse is a fixed-width TTL-level reference pulse used to trigger oscilloscopes or other measurement systems.

The TRIG output precedes the main output. These pulses are illustrated below:

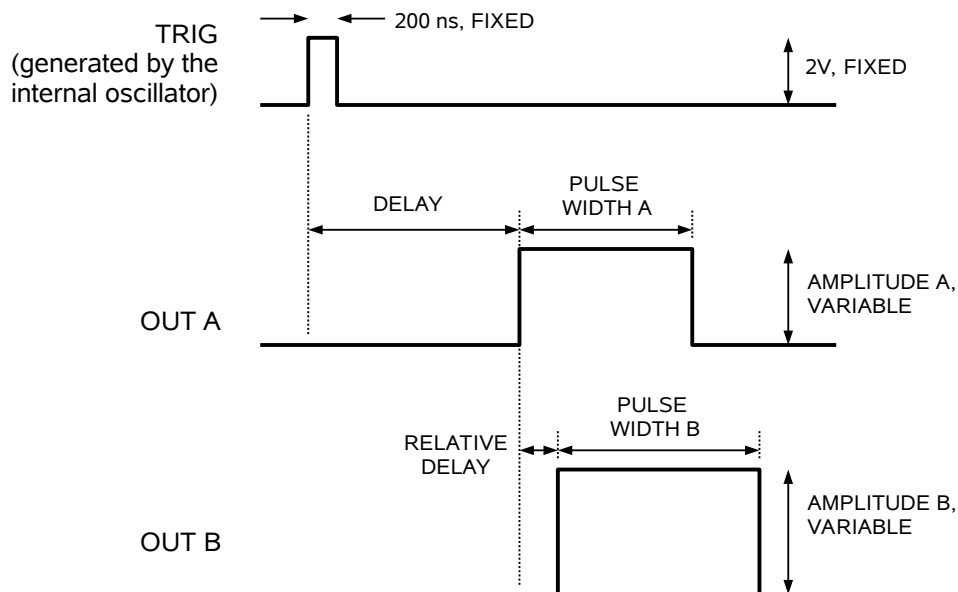

When triggered externally, the TRIG connector acts as an input. The delay controls do not function in this mode. This illustrated below:

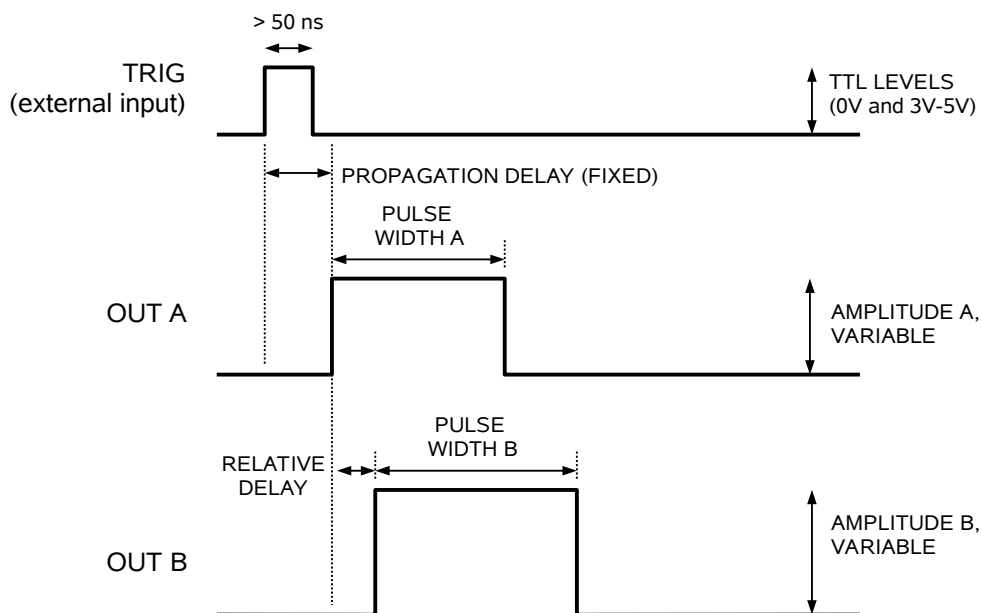

AMPLITUDE INTERACTION

Some properties of the output pulse may change as a function of the amplitude setting. For some demanding applications, it may be desirable to use a combination of external attenuators and the amplitude pot to achieve the desired output amplitude.

MINIMIZING WAVEFORM DISTORTIONS

USE 50Ω TRANSMISSION LINES AND LOADS

Connect the load to the pulse generator with 50Ω transmission lines (e.g. RG-58 or RG-174 cable).

This instrument requires a 50Ω load for proper operation. It will not properly drive a high-impedance load. The output stage will be damaged if it is operated into an open circuit (or any other high impedance). Failures due to improper output loading are not covered by the warranty.

USE LOW-INDUCTANCE LOADS

Lenz's Law predicts that for an inductive voltage spike will be generated when the current through an inductance changes. Specifically, $V_{\text{SPIKE}} = L \times dI_{\text{LOAD}}/dt$, where L is the inductance, I_{LOAD} is the load current change, and t is time. For this reason, it is important to keep any parasitic in the load low. This means keeping wiring short, and using low inductance components. In particular, wire-wound resistors should be avoided.

PREVENTING DAMAGE

The AVP-AVMP-2CHPP-UBB-C may fail if triggered at a PRF greater than 1 MHz.

This unit is designed to operate into a load impedance of 50 Ohms and the output stage will be damaged if it is operated into an open circuit (or any other high impedance). Failures due to improper output loading are not covered by the warranty.

The lifetime of the switching elements in the pulse generator module is proportional to the running time of the instrument. For this reason the prime power to the instrument should be turned off when the instrument is not in use.

The maximum duty cycle rating is 5%, so the PRF range switch should be set to the 100 kHz range (or lower) when the PW B range switch is set in the 1 us position. Operation at duty cycles above 5% may damage the instrument.

MECHANICAL INFORMATION

TOP COVER REMOVAL

If necessary, the interior of the instrument may be accessed by removing the four Phillips screws on the top panel. With the four screws removed, the top cover may be slid back (and off).

 Always disconnect the power cord and allow the instrument to sit unpowered for 10 minutes before opening the instrument. This will allow any internal stored charge to discharge.

There are no user-adjustable internal circuits. For repairs other than fuse replacement, please contact Avtech (info@avtechpulse.com) to arrange for the instrument to be returned to the factory for repair. Service is to be performed solely by qualified service personnel.

 Caution: High voltages are present inside the instrument during normal operation. Do not operate the instrument with the cover removed.

RACK MOUNTING

A rack mounting kit is available. The -R5 rack mount kit may be installed after first removing the one Phillips screw on the side panel adjacent to the front handle.

ELECTROMAGNETIC INTERFERENCE

To prevent electromagnetic interference with other equipment, all used outputs should be connected to shielded loads using shielded coaxial cables. Unused outputs should be terminated with shielded coaxial terminators or with shielded coaxial dust caps, to prevent unintentional electromagnetic radiation. All cords and cables should be less than 3m in length.

MAINTENANCE

REGULAR MAINTENANCE

This instrument does not require any regular maintenance.

On occasion, one or more of the four rear-panel fuses may require replacement. All fuses can be accessed from the rear panel. See the “FUSES” section for details.

CLEANING

If desired, the interior of the instrument may be cleaned using compressed air to dislodge any accumulated dust. (See the “TOP COVER REMOVAL” section for instructions on accessing the interior.) No other cleaning is recommended.

WIRING DIAGRAMS

WIRING OF AC POWER

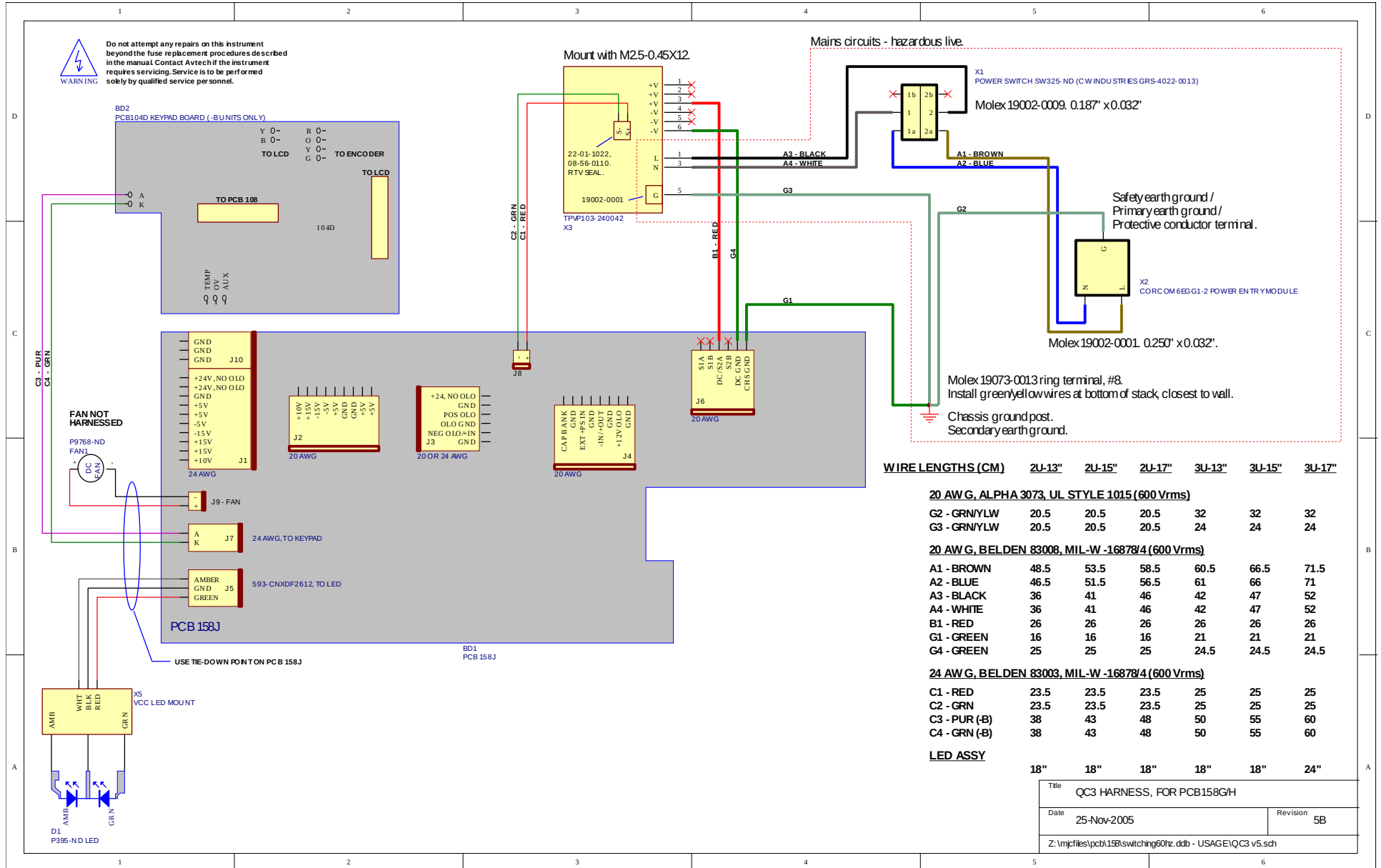

PCB 158K - LOW VOLTAGE POWER SUPPLY, 1/3

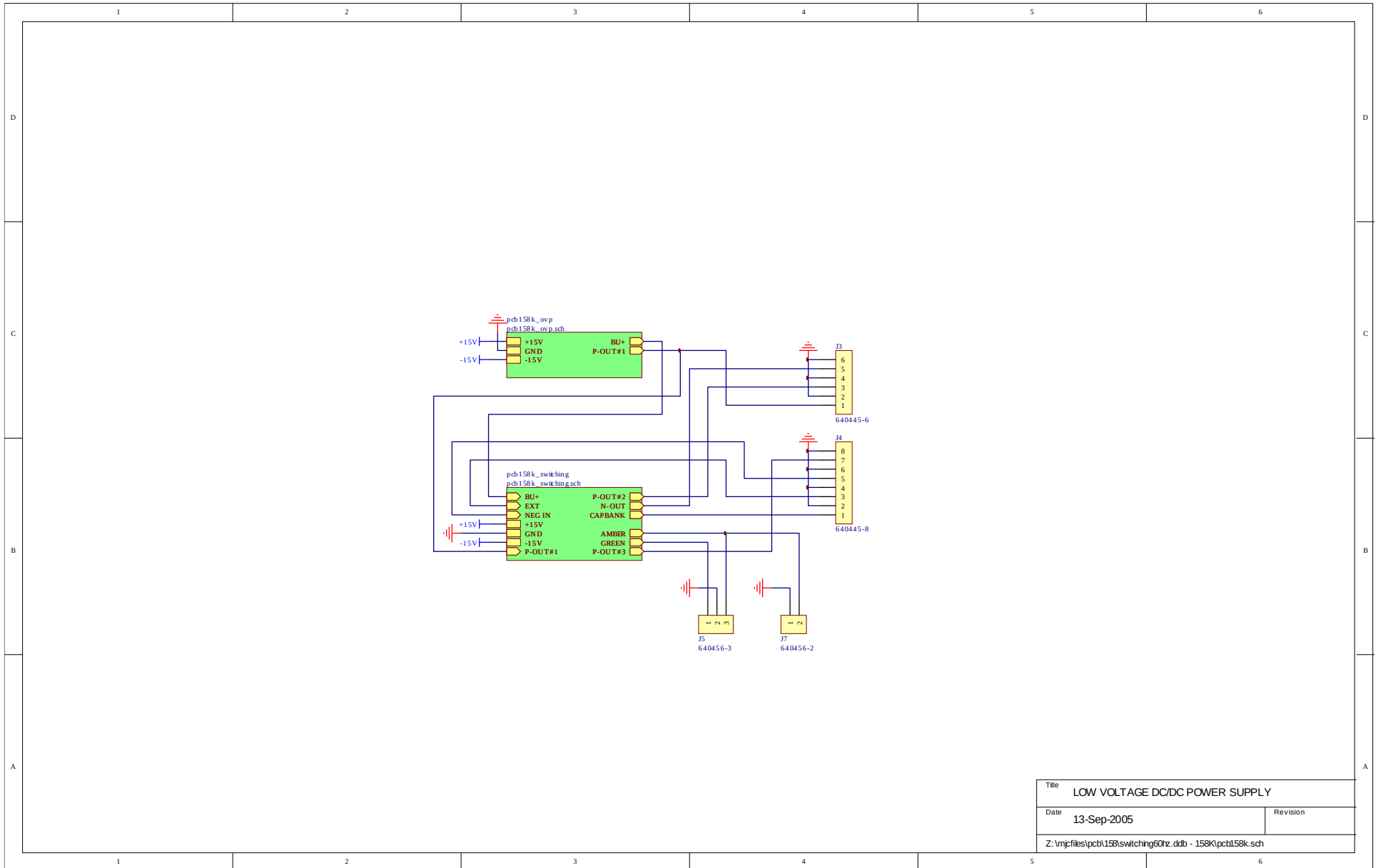

Title	LOW VOLTAGE DC/DC POWER SUPPLY	
Date	13-Sep-2005	Revision
Z:\mpjfiles\pcb158\switching01rz.ddb - 158K\pcb158k.sch		

PCB 158K - LOW VOLTAGE POWER SUPPLY, 2/3

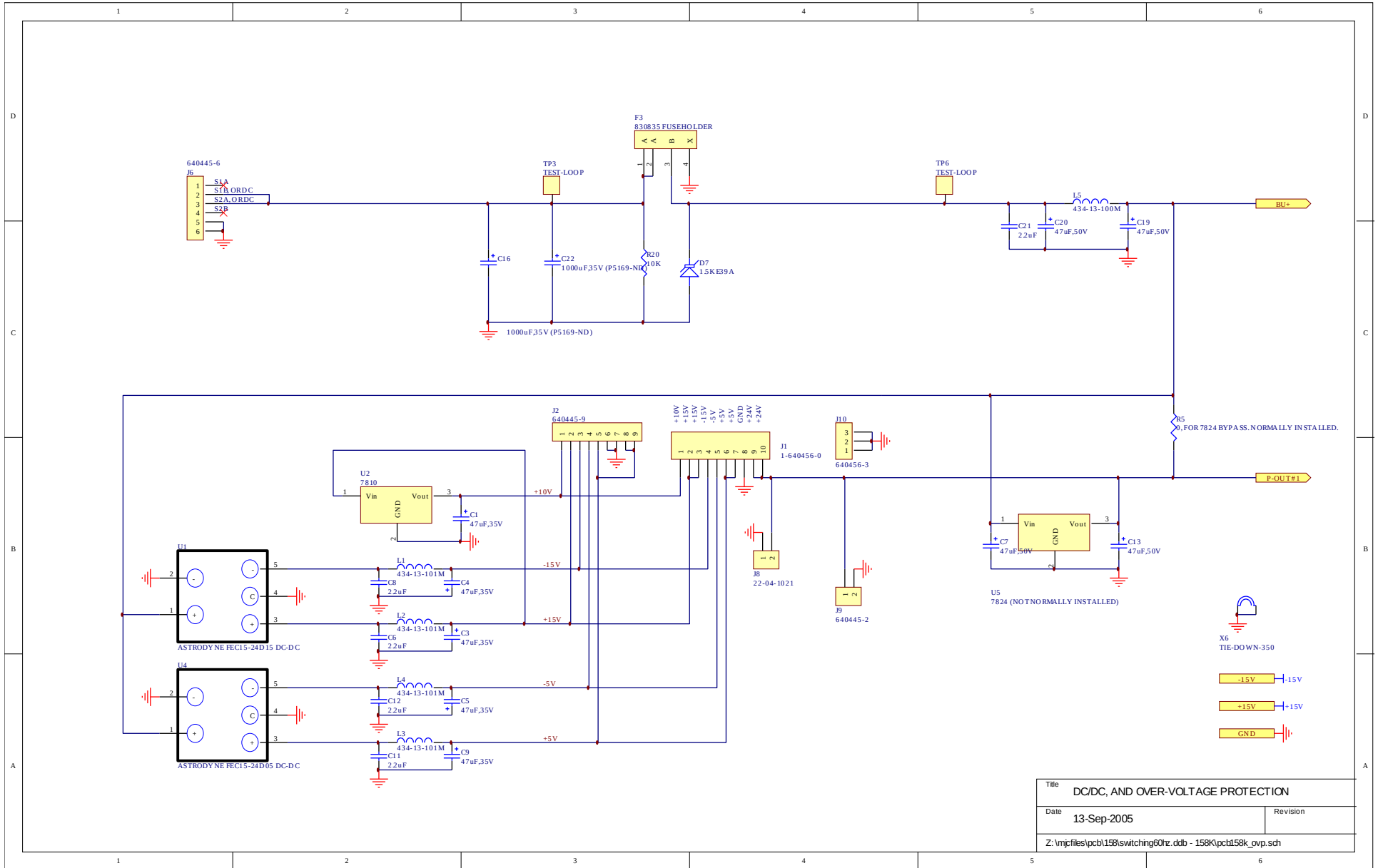

PCB 158K - LOW VOLTAGE POWER SUPPLY, 3/3

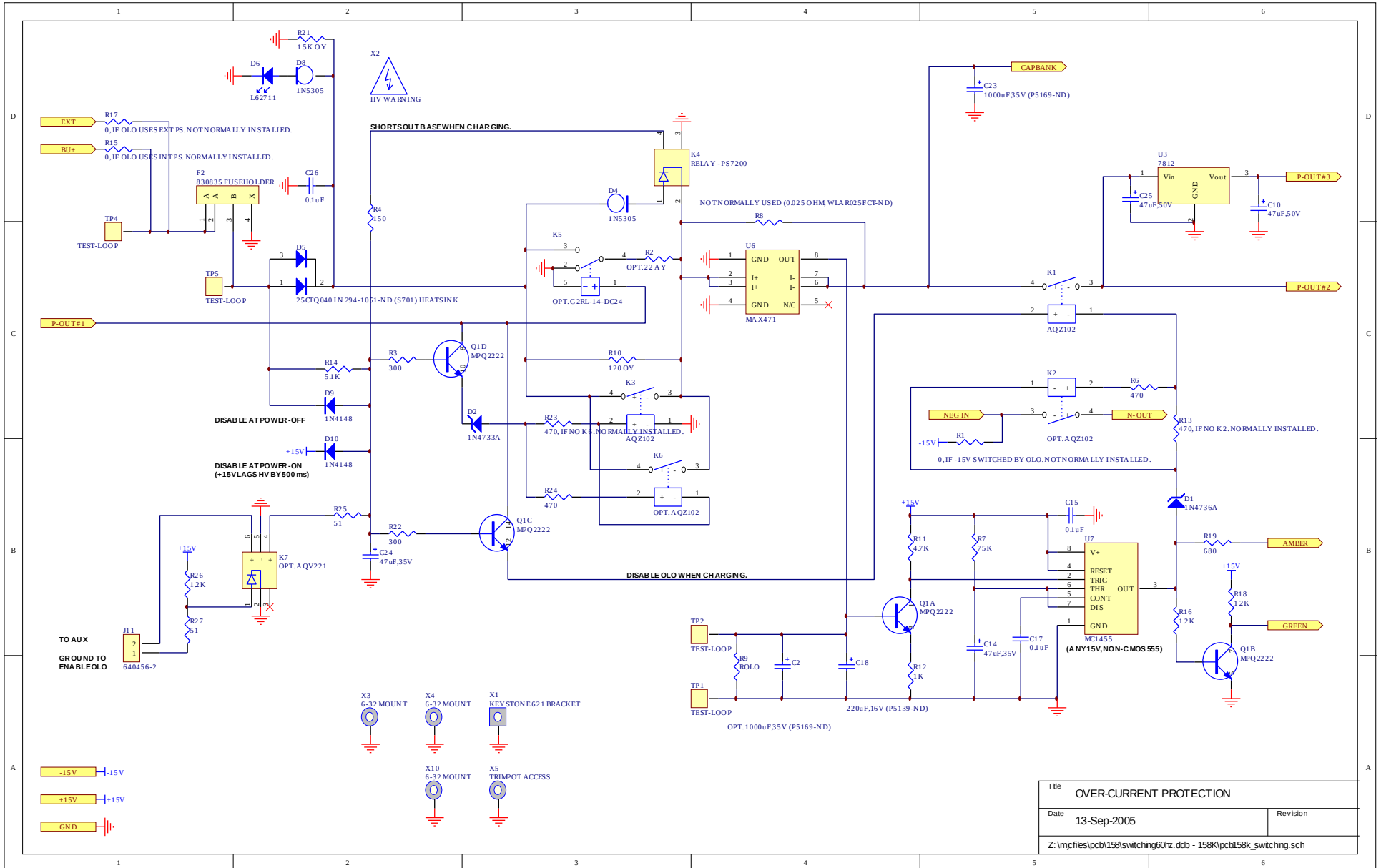

PCB 168B - HIGH VOLTAGE DC POWER SUPPLY

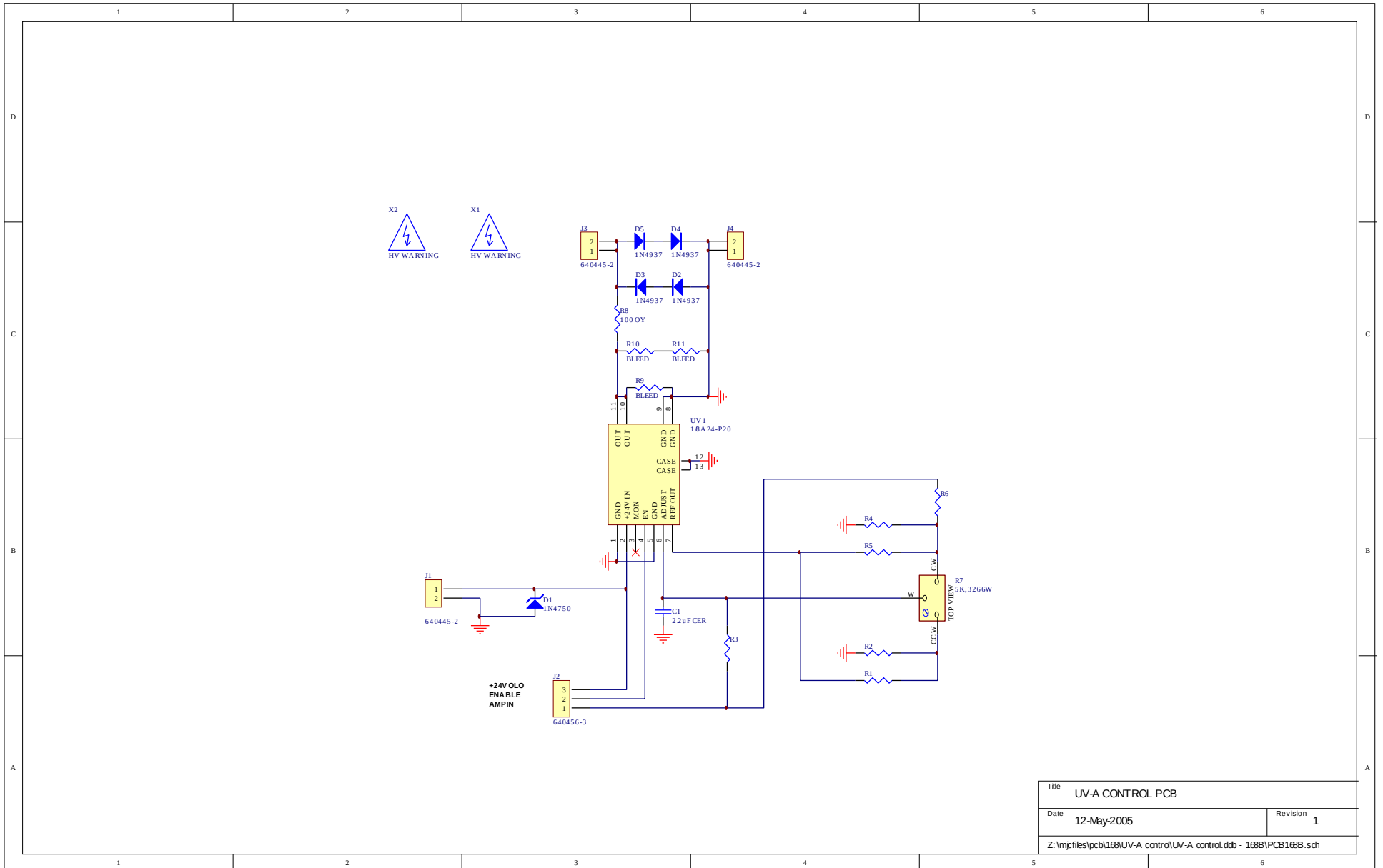

Title UV-A CONTROL PCB	
Date 12-May-2005	Revision 1
Z:\mpjfiles\pcb168\UV-A control\UV-A control.ddb - 168B\PCB168B.sch	

PCB 126B - OSCILLATOR AND TRIGGER CIRCUIT

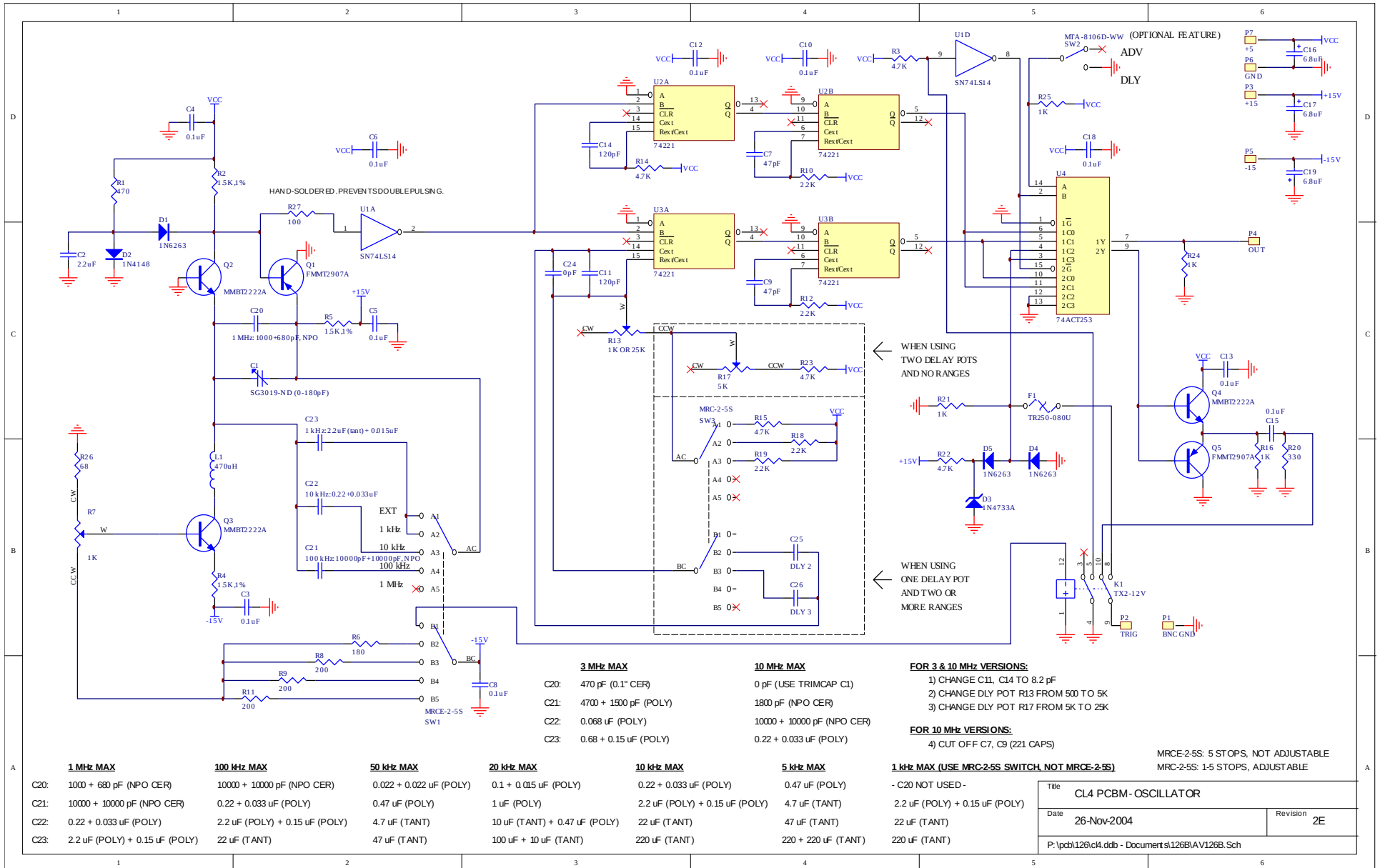

PERFORMANCE CHECK SHEET