

INSTRUCTIONS

MODEL AVPP-2-B

0 TO 20 VOLTS, 100 kHz
HIGH PERFORMANCE PULSE GENERATOR
WITH IEEE 488.2 AND RS-232 CONTROL

SERIAL NUMBER: _____

WARRANTY

Avtech Electrosystems Ltd. warrants products of its manufacture to be free from defects in material and workmanship under conditions of normal use. If, within one year after delivery to the original owner, and after prepaid return by the original owner, this Avtech product is found to be defective, Avtech shall at its option repair or replace said defective item. This warranty does not apply to units which have been disassembled, modified or subjected to conditions exceeding the applicable specifications or ratings. This warranty is the extent of the obligation assumed by Avtech with respect to this product and no other warranty or guarantee is either expressed or implied.

TECHNICAL SUPPORT

Phone: 613-226-5772 or 1-800-265-6681

Fax: 613-226-2802 or 1-800-561-1970

E-mail: info@avtechpulse.com

World Wide Web: <http://www.avtechpulse.com>

TABLE OF CONTENTS

WARRANTY	2
TECHNICAL SUPPORT	2
TABLE OF CONTENTS	3
INTRODUCTION	5
AVAILABLE OPTIONS	5
SPECIFICATIONS	6
INSTALLATION	7
VISUAL CHECK	7
PLUGGING IN THE INSTRUMENT	7
LABVIEW DRIVERS	8
FRONT PANEL CONTROLS	9
REAR PANEL CONTROLS	11
GENERAL INFORMATION	13
BASIC PULSE CONTROL	13
TRIGGER MODES	14
GATING MODES	15
OPERATION AT LOW AMPLITUDES	15
TOP COVER REMOVAL	15
ELECTROMAGNETIC INTERFERENCE	15
OPTIONAL FEATURES	16
RACK MOUNTING, "-R5" OPTION	16
DC OFFSET, "-OT" OPTION	16
DC OFFSET, "-EO" OPTION	16
MONITOR OUTPUT, "-M" OPTION	16
ELECTRONIC AMPLITUDE CONTROL, "-EA" OPTION	16
PROTECTING YOUR INSTRUMENT	17
TURN OFF INSTRUMENT WHEN NOT IN USE	17
DO NOT EXCEED 100 kHz	17
USE A 50 Ω LOAD	17
OPERATIONAL CHECK	18

<i>PROGRAMMING YOUR PULSE GENERATOR</i>	22
KEY PROGRAMMING COMMANDS	22
ALL PROGRAMMING COMMANDS	23
<i>PERFORMANCE CHECKSHEET</i>	25

Manual Reference: /fileserver1/officefiles/instructword/avpp/obsolete versions/AVPP-2-B,edition1.doc, created March 28, 2002

INTRODUCTION

The AVPP-2-B is a high performance, GPIB and RS232-equipped instrument capable of generating 20V into 50 Ω loads at repetition rates up to 100 kHz. The output pulse width is variable from 0.4 to 100 ns, and the sync delay is variable up to ± 500 ns. The rise time is fixed at less than 200 ps, and the fall time is less than 300 ps.

Instruments with the "-P" model suffix can generate 0 to +20V, whereas instruments with the "-N" model suffix can generate 0 to -20V. Instruments with the "-PN" suffix can generate both polarities.

The AVPP-2-B is a highly flexible instrument. Aside from the internal trigger source, it can also be triggered or gated by external TTL-level signals. A front-panel pushbutton or a computer command can also be used to trigger the instrument.

The AVPP-2-B features front panel keyboard and adjust knob control of the output pulse parameters along with a four line by 40-character backlit LCD display of the output amplitude, pulse width, pulse repetition frequency, and delay. The instrument includes memory to store up to four complete instrument setups. The operator may use the front panel or the computer interface to store a complete "snapshot" of all key instrument settings, and recall this setup at a later time.

AVAILABLE OPTIONS

The AVPP-2-B is available with several options:

"-OT" Option: this option adds an internally-generated 0 to ± 5 V DC offset to the main output.

"-EO" Option: the DC offset can be controlled by an externally generated 0 to +10V analog control voltage.

"-EA" Option: the amplitude can be controlled by an externally generated 0 to +10V analog control voltage.

"-M" Option: a monitor output is provided.

"-R5" Option: A rack mounting kit is available. The "-R5" rack mount kit may be installed after first removing the one Phillips screw on the side panel adjacent to the front handle.

SPECIFICATIONS

Model:	AVPP-2-B ²
Amplitude ³ : (50 Ohm load)	Variable to 20 Volts
Pulse width ³ :	Variable 0.4 ns to 100 ns in two ranges (0.4 to 8.0 ns and 8.0 to 100 ns)
PRF: external trigger mode: internal trigger:	0 to 100 kHz 1 Hz to 100 kHz
Rise and fall times: (add 20% if inverting transformer used)	$t_{RISE} \leq 200\text{ps}$, $t_{FALL} \leq 300\text{ps}$
Polarity ⁴ :	Positive or negative or both (specify)
GPIB and RS-232 control ² :	Standard on -B units.
LabView Drivers:	Check http://www.avtechpulse.com/labview for availability and downloads
Propagation delay:	$\leq 100\text{ ns}$ (Ext trig in to pulse out)
Jitter:	$\pm 35\text{ps} \pm 0.015\%$ of sync delay
DC offset or bias insertion ^{3,5} :	Apply required DC offset to back panel solder terminals ($\pm 50\text{ Volts}$, 250 mA max)
Trigger required:	Ext trig mode: +5 Volts, 10 ns or wider (TTL)
Sync delay:	Sync out to pulse out: Variable 0 to 200 ns
Sync output:	+3 Volts, 200 ns, will drive 50 Ohm loads
Monitor output option ⁶ :	Provides a 20 dB attenuated coincident replica of main output
Connectors:	Out: SMA, Trig: BNC, Sync: BNC, Gate: BNC, Monitor: SMA
Power requirements:	120/240 Volts (switchable) 50-60 Hz
Dimensions: (H x W x D)	100 mm x 430 mm x 375 mm (3.9" x 17" x 14.8")
Chassis material:	cast aluminum frame & handles, blue vinyl on aluminum cover plates
Mounting, temperature range:	Any, +10°C to +40°C

2) -B suffix indicates IEEE-488.2 GPIB and RS-232 control of amplitude, pulse width, PRF and delay.

3) For analog electronic control (0 to +10V) of amplitude, pulse width, or offset, suffix model number with -EA, -EW, or -EO.

Electronic control units also include standard front-panel controls. -EW not available on -B units.

4) Indicate desired polarity by suffixing model number with -P or -N (i.e. positive or negative) or -P-PN or -N-PN for dual polarity option where the suffix preceding -PN indicates the polarity at the mainframe output port.

5) Add -OT to model number for internally generated 0 to $\pm 5\text{V}$ offset option.

6) Add -M to model number for monitor option.

INSTALLATION

VISUAL CHECK

After unpacking the instrument, examine to ensure that it has not been damaged in shipment. Visually inspect all connectors, knobs, liquid crystal displays (LCDs), and the handles. Confirm that a power cord, a GPIB cable, and two instrumentation manuals (this manual and the "OP1B Interface Programming Manual") are with the instrument. If the instrument has been damaged, file a claim immediately with the company that transported the instrument.

PLUGGING IN THE INSTRUMENT

Examine the rear of the instrument. There will be a male power receptacle, a fuse holder and the edge of the power selector card visible. Confirm that the power selector card is in the correct orientation.

For AC line voltages of 110-120V, the power selector card should be installed so that the "120" marking is visible from the rear of the instrument, as shown below:

For AC line voltages of 220-240V, the power selector card should be installed so that the "240" marking is visible from the rear of the instrument, as shown below:

If it is not set for the proper voltage, remove the fuse and then grasp the card with a pair of pliers and remove it. Rotate horizontally through 180 degrees. Reinstall the card and the correct fuse.

In the 120V setting, a 1.0A slow blow fuse is required. In the 240V setting, a 0.5A slow blow fuse is required.

LABVIEW DRIVERS

A LabVIEW driver for this instrument is available for download on the Avtech web site, at <http://www.avtechpulse.com/labview>. A copy is also available in National Instruments' Instrument Driver Library at <http://www.natinst.com/>.

FRONT PANEL CONTROLS

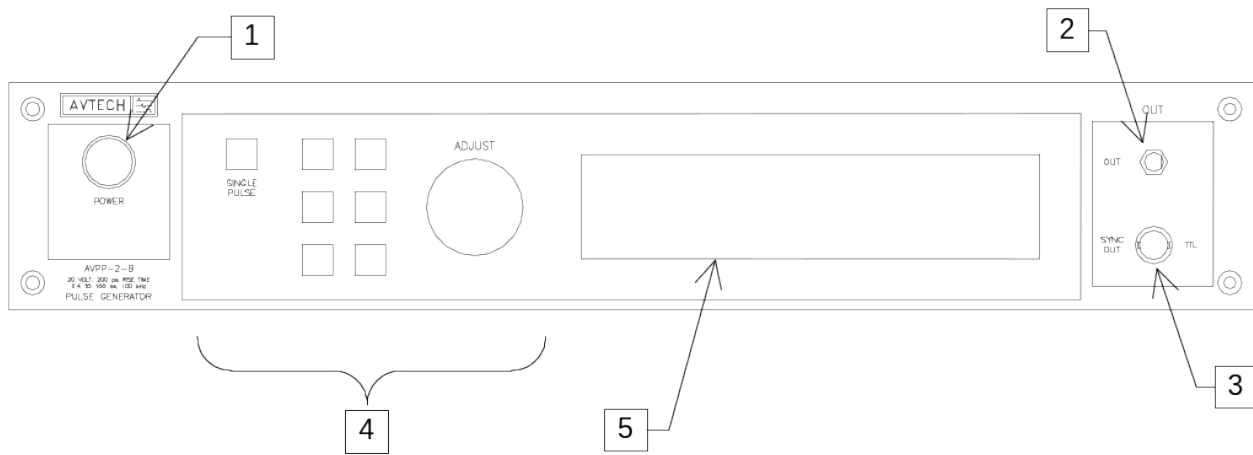

1. POWER Switch. The POWER push button switch applies AC prime power to the primaries of the transformer, turning the instrument on. The push button lamp (#382 type) is connected to the internal +15V DC supply.
2. OUT CONNECTOR. This BNC connector provides the main output signal, into load impedances of 50Ω.
3. SYNC OUT. This connector supplies a SYNC output that can be used to trigger other equipment, particularly oscilloscopes. This signal leads (or lags) the main output by a duration set by the "DELAY" controls and has an approximate amplitude of +3 Volts to $R_L > 1k\Omega$ with a pulse width of approximately 200 ns.
4. LIQUID CRYSTAL DISPLAY (LCD). This LCD is used in conjunction with the keypad to change the instrument settings. Normally, the main menu is displayed, which lists the key adjustable parameters and their current values. The "OP1B Interface Programming Manual" describes the menus and submenus in detail.
5. KEYPAD.

Control Name	Function
MOVE	This moves the arrow pointer on the display.
CHANGE	This is used to enter the submenu, or to select the operating mode, pointed to by the arrow pointer.
×10	If one of the adjustable numeric parameters is displayed, this increases the setting by a factor of ten.
÷10	If one of the adjustable numeric parameters is displayed, this decreases the setting by a factor of ten.
+/-	If one of the adjustable numeric parameters is displayed, and

	this parameter can be both positive or negative, this changes the sign of the parameter.
EXTRA FINE	This changes the step size of the ADJUST knob. In the extra-fine mode, the step size is twenty times finer than in the normal mode. This button switches between the two step sizes.
ADJUST	<p>This large knob adjusts the value of any displayed numeric adjustable values, such as frequency, pulse width, etc. The adjust step size is set by the "EXTRA FINE" button.</p> <p>When the main menu is displayed, this knob can be used to move the arrow pointer.</p>

REAR PANEL CONTROLS

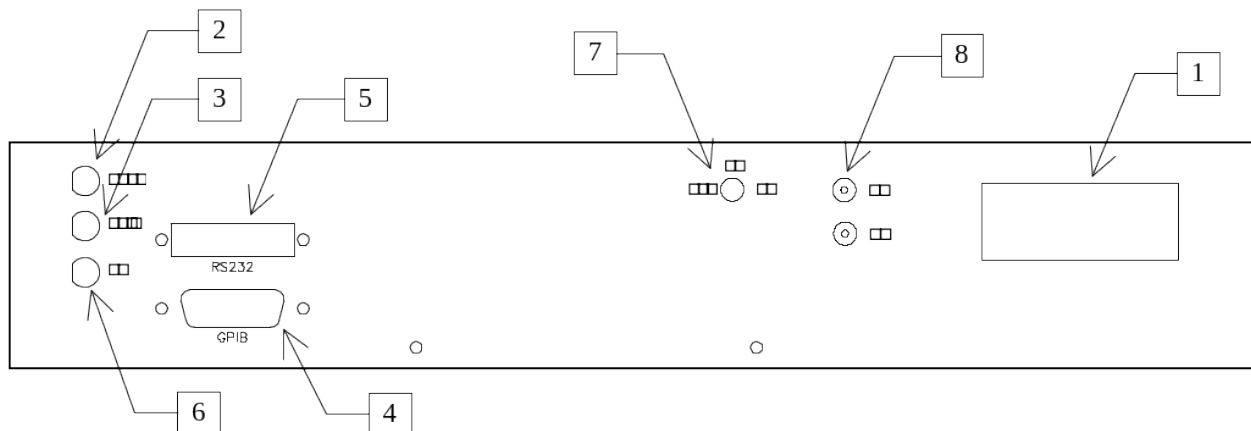

1. **AC POWER INPUT.** A three-pronged recessed male connector is provided on the back panel for AC power connection to the instrument. Also contained in this assembly is a slow-blow fuse and a removable card that can be removed and repositioned to switch between 120V AC in and 240V AC in.

For AC line voltages of 110-120V, the power selector card should be installed so that the “120” marking is visible from the rear of the instrument.

For AC line voltages of 220-240V, the power selector card should be installed so that the “240” marking is visible from the rear of the instrument.

If it is not set for the proper voltage, remove the fuse and then grasp the card with a pair of pliers and remove it. Rotate horizontally through 180 degrees. Reinstall the card and the correct fuse.

In the 120V setting, a 1.0A slow blow fuse is required. In the 240V setting, a 0.5A slow blow fuse is required. See the “Installation” section for more details.

2. **GATE.** This TTL-level (0 and +5V) logic input can be used to gate the triggering of the instrument. This input can be either active high or active low, depending on the front panel settings or programming commands. (The instrument triggers normally when this input is unconnected).
3. **TRIG.** This TTL-level (0 and +5V) logic input can be used to trigger the instrument, if the instrument is set to triggering externally. The instrument triggers on the rising edge of this input. The instrument can also be set such that the output pulse width tracks the pulse width on this input, or the output pulse width can be set independently.
4. **GPIB Connector.** A standard GPIB cable can be attached to this connector to allow the instrument to be computer-controlled. See the “OP1B Interface Programming

Manual” for more details on GPIB control.

5. RS-232 Connector. A standard serial cable with a 25-pin male connector can be attached to this connector to allow the instrument to be computer-controlled. See the “OP1B Interface Programming Manual” for more details on RS-232 control.
6. OS Connector. The desired DC offset is applied to this connector. Internally, it is connected to the output centre conductor via a high quality RF inductor. Do not exceed $\pm 50\text{V}$, 250 mA. When the -OT option is present, this connector is only active if the OS switch (item 7) is in the “OFF” position (i.e., the internal offset source is disabled). If this input is not used, it should be connected to ground (zero Volts).
7. OS Switch. This is present for models with the -OT option only. When this switch is set to “ON”, the offset present on the output is controlled by the front-panel controls, or by computer commands. When this switch is set to “OFF”, the offset is controlled by an external voltage applied to the OS connector (item 6).
8. M Connectors. (Optional feature. Present on "-M" units only.) The monitor outputs provides an attenuated replica (20 dB down) of the voltage on the main output. The monitor output is designed to operate into a 50 Ohm load. The MA connector is used when the output pulse width is between 0.4 and 8 ns, and the MB connector is used when the output pulse width is between 8 and 100 ns.

Some models may also have:

AMP Connector. (Optional feature. Present on "-EA" units only.) The output amplitude can be set to track the voltage on this input. Zero Volts in corresponds to zero amplitude output, and +10V in corresponds to maximum amplitude out. This mode is activated by selecting "Ext Control" on the front-panel amplitude menu, or with the "source:voltage external" command.

GENERAL INFORMATION

BASIC PULSE CONTROL

This instrument can be triggered by its own internal clock or by an external TTL trigger signal. In either case, two output channels respond to the trigger: OUT and SYNC.

- OUT. This is the main output.
- SYNC. The SYNC pulse is a fixed-width TTL-level reference pulse used to trigger oscilloscopes or other measurement systems. When the delay is set to a positive value the SYNC pulse precedes the OUT pulse. When the delay is set to a negative value the SYNC pulse follows the OUT pulse.

These pulses are illustrated below, assuming internal triggering and a positive delay:

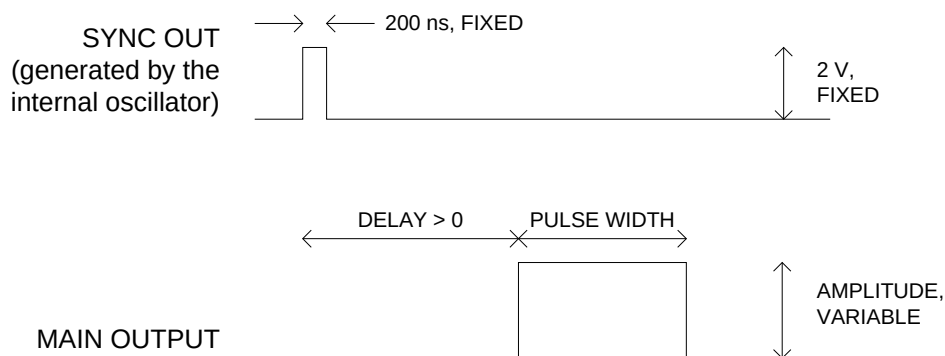

Figure A

If the delay is negative, the order of the SYNC and OUT pulses is reversed:

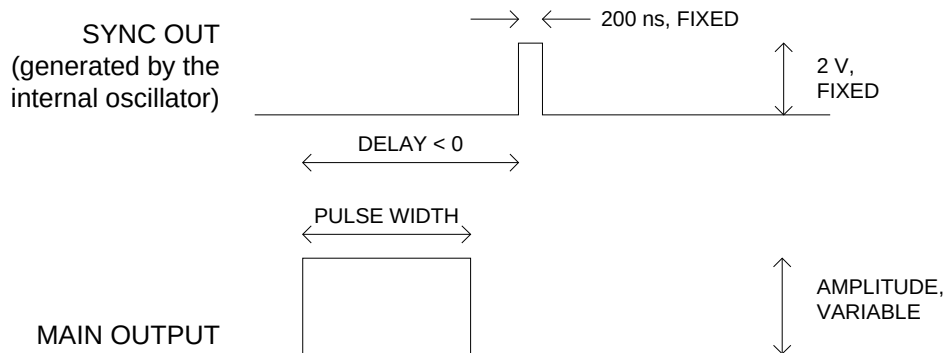

Figure B

The next figure illustrates the relationship between the signal when an external TTL-level trigger is used:

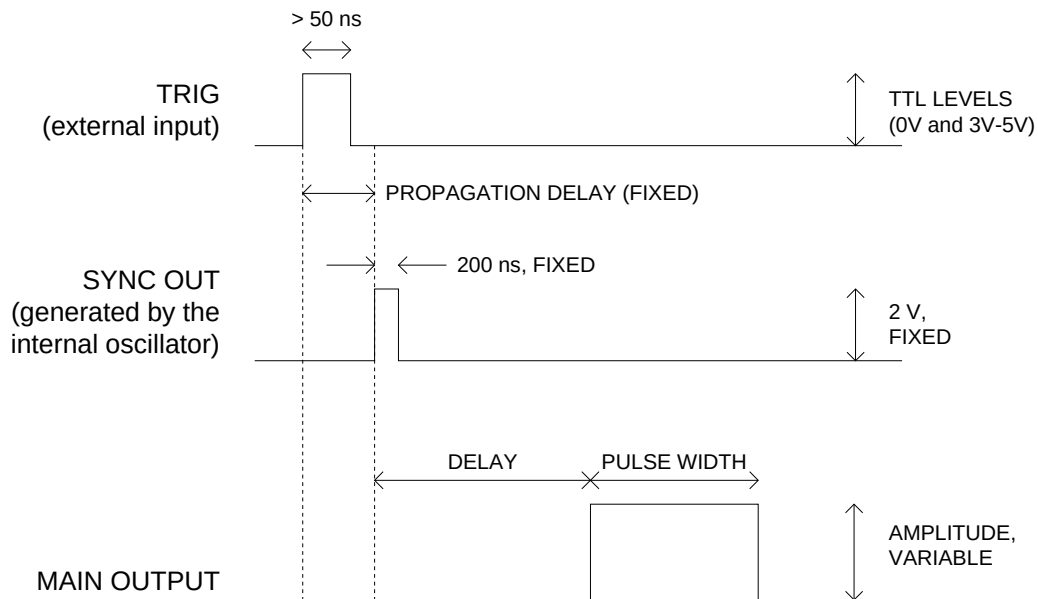

Figure C

As before, if the delay is negative, the order of the SYNC and OUT pulses is reversed.

In general, the delay, pulse width, and frequency (when in the internal mode), of the OUT pulse can be varied with front panel controls or via the GPIB or RS-232 computer interfaces.

TRIGGER MODES

This instrument has four trigger modes:

- Internal Trigger: the instrument controls the trigger frequency, and generates the clock internally.
- External Trigger: the instrument is triggered by an external TTL-level clock on the back-panel TRIG connector.
- Manual Trigger: the instrument is triggered by the front-panel "SINGLE PULSE" pushbutton.

- Hold Trigger: the instrument is set to not trigger at all.

These modes can be selected using the front panel trigger menu, or by using the appropriate programming commands. (See the “OP1B Interface Programming Manual” for more details.)

GATING MODES

Triggering can be suppressed by a TTL-level signal on the rear-panel GATE connector. The instrument can be set to stop triggering when this input high or low, using the front-panel gate menu or the appropriate programming commands. When gated, the output will complete the full pulse width if the output is high, and then stop triggering. Pulses are not truncated.

OPERATION AT LOW AMPLITUDES

This instrument will generate the best waveforms when operated near maximum amplitude. If amplitudes less than 1/3 of the full-scale value are desired, better results will be obtained if the pulse generator is operated at a higher amplitude, and an attenuator is connected to the output. Avtech recommends the ATT-0444-XX-SMA-02 series of 18 GHz coaxial attenuators from Midwest Microwave, <http://www.midwestmicrowave.com/>. (The “XX” in the part number is replaced with the numeric attenuation value in dB).

TOP COVER REMOVAL

The interior of the instrument may be accessed by removing the four Phillips screws on the top panel. With the four screws removed, the top cover may be slid back (and off).

ELECTROMAGNETIC INTERFERENCE

To prevent electromagnetic interference with other equipment, all used outputs should be connected to shielded 50 Ω loads using shielded 50 Ω coaxial cables. Unused outputs should be terminated with shielded 50 Ω BNC terminators or with shielded BNC dust caps, to prevent unintentional electromagnetic radiation. All cords and cables should be less than 3m in length.

OPTIONAL FEATURES

RACK MOUNTING, "-R5" OPTION

A rack mounting kit is available. The "-R5" rack mount kit may be installed after first removing the one Phillips screw on the side panel adjacent to the front handle.

DC OFFSET, "-OT" OPTION

This option adds an internally-generated 0 to $\pm 5V$ DC offset to the main output. The offset level is set by the front-panel controls, or by computer commands. The rear-panel OS switch must be set to "ON" to activate the internally-generated offset feature.

DC OFFSET, "-EO" OPTION

This option allows adds a DC offset to the main output, which is controlled by an externally generated 0 to +10V analog control voltage applied to a rear-panel connector.

MONITOR OUTPUT, "-M" OPTION

The monitor output provides an attenuated replica (20 dB down) of the voltage on the main output. The monitor output is designed to operate into a 50 Ohm load.

ELECTRONIC AMPLITUDE CONTROL, "-EA" OPTION

The output amplitude can be set to track the voltage on this input. Zero Volts in corresponds to zero amplitude output, and +10V in corresponds to maximum amplitude out. This mode is activated by selecting "Ext Control" on the front-panel amplitude menu, or with the "source:voltage external" command.

PROTECTING YOUR INSTRUMENT

TURN OFF INSTRUMENT WHEN NOT IN USE

The lifetime of the switching elements in the pulse generator module is proportional to the running time of the instrument. For this reason the prime power to the instrument should be turned off when the instrument is not in use. In the case of failure, the switching elements are easily replaced following the procedure described in a following section.

DO NOT EXCEED 100 kHz

The output stage may be damaged if triggered by an external signal at a pulse repetition frequency greater than 100 kHz.

USE A 50 Ω LOAD

The output stage may be damaged if the output is not terminated into a 50 Ω load.

OPERATIONAL CHECK

This section describes a sequence to confirm the basic operation of the instrument. It should be performed after receiving the instrument. It is a useful learning exercise as well.

Before proceeding with this procedure, finish reading this instruction manual thoroughly. Then read the “Local Control” section of the “OP1B Interface Programming Manual” thoroughly. The “Local Control” section describes the front panel controls used in this operational check - in particular, the MOVE, CHANGE, and ADJUST controls.

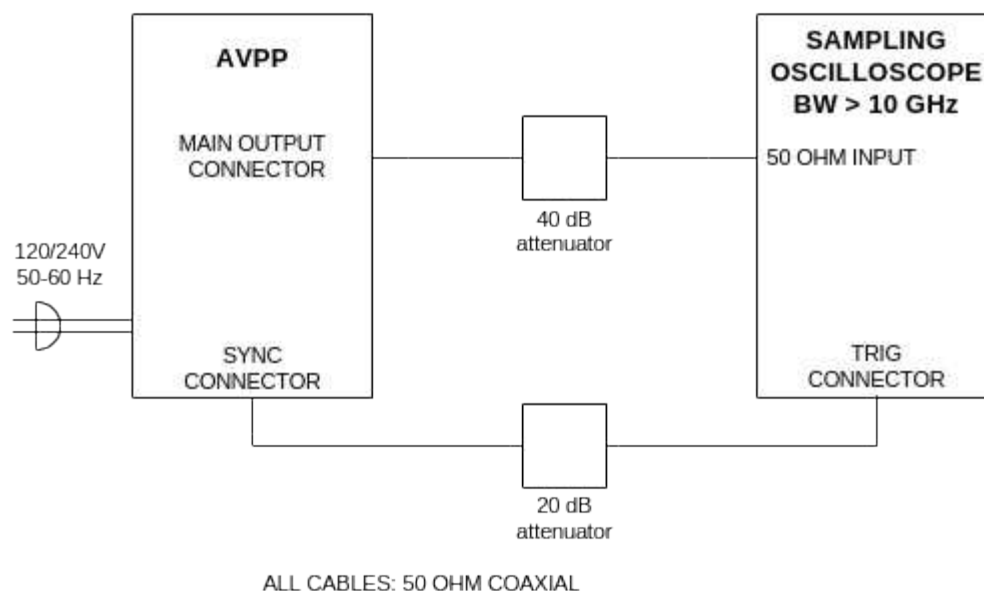

BASIC TEST ARRANGEMENT

1. Connect the pulse generator to a sampling oscilloscope as shown above. Note that:
 - a) The use of 40 dB attenuator at the sampling scope vertical input channel will insure a peak input signal to the sampling scope of less than 1 Volt. Factory tests are conducted using Midwest Microwave model ATT-0444-20-SMA-02 attenuators.
 - b) The TRIG output channel provides TTL level signals (approximately 0 and +3V). To avoid overdriving the TRIG input channel of some scopes, a 20 dB attenuator should be placed at the input to the scope trigger channel.

- c) The bandwidth capability of components and instruments used to display the pulse generator output signal (attenuators, cables, connectors, etc.) should exceed 10 GHz.
 - d) Set the oscilloscope to trigger externally with the vertical setting at 100 mV/div and the horizontal setting at 10 ns/div.
2. Turn on the AVPP-2-B. The main menu will appear on the LCD.
 3. To set the AVPP-2-B to trigger from the internal clock at a PRF of 10 kHz:
 - a) The arrow pointer should be pointing at the frequency menu item. If it is not, press the MOVE button until it is.
 - b) Press the CHANGE button. The frequency submenu will appear. Rotate the ADJUST knob until the frequency is set at 10 kHz.
 - c) The arrow pointer should be pointing at the "Internal" choice. If it is not, press MOVE until it is.
 - d) Press CHANGE to return to the main menu.
 4. To set the delay to 100 ns:
 - a) Press the MOVE button until the arrow pointer is pointing at the delay menu item.
 - b) Press the CHANGE button. The delay submenu will appear. Rotate the ADJUST knob until the delay is set at 100 ns. (Note that it may be necessary to adjust the delay setting within a ± 5 ns range to obtain optimum jitter performance, as the jitter has a slight periodic delay dependency.)
 - c) The arrow pointer should be pointing at the "Normal" choice. If it is not, press MOVE until it is.
 - d) Press CHANGE to return to the main menu.
 5. To set the pulse width to 60 ns:
 - a) Press the MOVE button until the arrow pointer is pointing at the pulse width menu item.
 - b) Press the CHANGE button. The pulse width submenu will appear. Rotate the ADJUST knob until the pulse width is set at 60 ns.

- c) The arrow pointer should be pointing at the "Normal" choice. If it is not, press MOVE until it is.
 - d) Press CHANGE to return to the main menu.
6. At this point, nothing should appear on the oscilloscope.
7. To enable the output:
 - a) Press the MOVE button until the arrow pointer is pointing at the output menu item.
 - b) Press the CHANGE button. The output submenu will appear.
 - c) Press MOVE until the arrow pointer is pointing at the "ON" choice.
 - d) Press CHANGE to return to the main menu.
8. To change the output amplitude:
 - a) Press the MOVE button until the arrow pointer is pointing at the amplitude menu item.
 - b) Press the CHANGE button. The amplitude submenu will appear. Rotate the ADJUST knob until the amplitude is set at +20V (or -20V for "-N" models).
 - c) Observe the oscilloscope. You should see 60 ns wide, 20V pulses. If you do not, you may need to adjust the delay setting to a value more compatible with your sampling oscilloscope. Repeat step 4 if required. You may also need to adjust the sampling scope controls.
 - d) Rotate the ADJUST knob. The amplitude as seen on the oscilloscope should vary. Return it to 20V.
 - e) ("-PN" units only) Press the +/- button on the front panel. The amplitude as seen on the oscilloscope should flip polarity, to -20V.
 - f) Press CHANGE to return to the main menu.
9. To set the pulse width to 6 ns:
 - a) Press the MOVE button until the arrow pointer is pointing at the pulse width menu item.

- b) Press the CHANGE button. The pulse width submenu will appear. Rotate the ADJUST knob until the pulse width is set at 6 ns.
- c) Observe the oscilloscope. You should see 6 ns wide, 20V pulses. If you do not, you may need to adjust the delay setting to a value more compatible with your sampling oscilloscope. Repeat step 4 if required. You may also need to adjust the sampling scope controls. Note that this pulser has two internal pulse width ranges (of 0.4 - 8 ns and 8 - 100 ns, approximately), and the internal propagation delay is 20 ns smaller in the wider pulse range than in the narrower pulse range.
- d) Press CHANGE to return to the main menu.

This completes the operational check.

PROGRAMMING YOUR PULSE GENERATOR

KEY PROGRAMMING COMMANDS

The "OP1B Interface Programming Manual" describes in detail how to connect the pulse generator to your computer, and the programming commands themselves. A large number of commands are available; however, normally you will only need a few of these. Here is a basic sample sequence of commands that might be sent to the instrument after power-up:

```
*rst                (resets the instrument)
trigger:source internal (selects internal triggering)
frequency 1000 Hz    (sets the frequency to 1000 Hz)
pulse:width 50 ns    (sets the pulse width to 50 ns)
pulse:delay 20 ns    (sets the delay to 20 ns)
volt:ampl 5          (sets the amplitude to +5 V)
                    ("-N" units should use "volt:ampl -5")
output on            (turns on the output)
```

For triggering a single event, this sequence would be more appropriate:

```
*rst                (resets the instrument)
trigger:source hold  (turns off all triggering)
pulse:width 50 ns    (sets the pulse width to 50 ns)
output on            (turns on the output)
volt:ampl 5          (sets the amplitude to +5 V)
                    ("-N" units should use "volt:ampl -5")
trigger:source immediate (generates a single non-repetitive trigger event)
trigger:source hold  (turns off all triggering)
output off           (turns off the output)
```

To set the instrument to trigger from an external TTL signal applied to the rear-panel TRIG connector, use:

```
*rst                (resets the instrument)
trigger:source external (selects external triggering)
pulse:width 50 ns    (sets the pulse width to 50 ns)
pulse:delay 1 us     (sets the delay to 1 us)
volt:ampl 5          (sets the amplitude to +5 V)
                    ("-N" units should use "volt:ampl -5")
output on            (turns on the output)
```

These commands will satisfy 90% of your programming needs.

ALL PROGRAMMING COMMANDS

For more advanced programmers, a complete list of the available commands is given below. These commands are described in detail in the “OP1B Interface Programming Manual”. (Note: this manual also includes some commands that are not implemented in this instrument. They can be ignored.)

<u>Keyword</u>	<u>Parameter</u>	<u>Notes</u>
LOCAL		
OUTPut:		
:[STATe]	<boolean value>	
:PROTection		
:TRIPped?		[query only]
REMOTE		
[SOURce]:		
:FREQuency		
[:CW FIXed]	<numeric value>	
[SOURce]:		
:PULSe		
:PERiod	<numeric value>	
:WIDTh	<numeric value>	
:DCYClE	<numeric value>	
:HOLD	WIDTh DCYClE	
:DELay	<numeric value>	
:GATE		
:TYPE	ASYNc SYNc	
:LEVel	HIGH LOW	
[SOURce]:		
:VOLTage		
[:LEVel]		
[:IMMediate]		
[:AMPLitude]	<numeric value> EXTeRnal	
:PROTection		
:TRIPped?		[query only]
STATUS:		
:OPERation		
:[EVENT]?		[query only, always returns "0"]
:CONDition?		[query only, always returns "0"]
:ENABle	<numeric value>	[implemented but not useful]
:QUESTionable		
:[EVENT]?		[query only, always returns "0"]
:CONDition?		[query only, always returns "0"]
:ENABle	<numeric value>	[implemented but not useful]
SYSTEM:		
:COMMunicate		
:GPIB		
:ADDReSS	<numeric value>	
:SERial		
:CONTRol		
:RTS	ON IBFull RFR	

: [RECeive]		
: BAUD	1200 2400 4800 9600	
: BITS	7 8	
: ECHO	<boolean value>	
: PARity		
: [TYPE]	EVEN ODD NONE	
: SBITS	1 2	
: ERror		
: [NEXT]?		[query only]
: COUNT?		[query only]
: VERSion?		[query only]
TRIGger:		
: SOURce	INTernal EXTernal MANual HOLD IMMEDIATE	
*CLS		[no query form]
*ESE	<numeric value>	
*ESR?		[query only]
*IDN?		[query only]
*OPC		
*SAV	0 1 2 3	[no query form]
*RCL	0 1 2 3	[no query form]
*RST		[no query form]
*SRE	<numeric value>	
*STB?		[query only]
*TST?		[query only]
*WAI		[no query form]

PERFORMANCE CHECKSHEET