

INSTRUCTIONS

MODEL AVR-3-C-N-KOPC-EA

DUAL-CHANNEL  
0 TO -300 VOLT  
PULSE GENERATOR

SERIAL NUMBER: \_\_\_\_\_

### WARRANTY

Avtech Electrosystems Ltd. warrants products of its manufacture to be free from defects in material and workmanship under conditions of normal use. If, within one year after delivery to the original owner, and after prepaid return by the original owner, this Avtech product is found to be defective, Avtech shall at its option repair or replace said defective item. This warranty does not apply to units which have been disassembled, modified or subjected to conditions exceeding the applicable specifications or ratings. This warranty is the extent of the obligation assumed by Avtech with respect to this product and no other warranty or guarantee is either expressed or implied.

### TECHNICAL SUPPORT

Phone: 613-226-5772 or 1-800-265-6681

Fax: 613-226-2802 or 1-800-561-1970

E-mail: [info@avtechpulse.com](mailto:info@avtechpulse.com)

World Wide Web: <http://www.avtechpulse.com>

## TABLE OF CONTENTS

<b>WARRANTY.....</b>	<b>1</b>
<b>TECHNICAL SUPPORT.....</b>	<b>1</b>
<b>TABLE OF CONTENTS.....</b>	<b>2</b>
<b>INTRODUCTION.....</b>	<b>3</b>
<b>SPECIFICATIONS.....</b>	<b>4</b>
<b>ORIGINAL QUOTATION.....</b>	<b>5</b>
<b>INSTALLATION.....</b>	<b>7</b>
<b>VISUAL CHECK.....</b>	<b>7</b>
<b>PLUGGING IN THE INSTRUMENT.....</b>	<b>7</b>
<b>FRONT PANEL CONTROLS.....</b>	<b>9</b>
<b>REAR PANEL CONTROLS.....</b>	<b>12</b>
<b>GENERAL INFORMATION.....</b>	<b>13</b>
<b>TEST ARRANGEMENT.....</b>	<b>13</b>
<b>MECHANICAL INFORMATION.....</b>	<b>15</b>
<b>TOP COVER REMOVAL.....</b>	<b>15</b>
<b>RACK MOUNTING.....</b>	<b>15</b>
<b>ELECTROMAGNETIC INTERFERENCE.....</b>	<b>15</b>
<b>POWER SUPPLY AND FUSE REPLACEMENT.....</b>	<b>16</b>
<b>PERFORMANCE CHECK SHEET.....</b>	<b>18</b>

## INTRODUCTION

The AVR-3-C-N-KOPC-EA is a special-purpose high-performance dual channel pulse generator capable of generating amplitudes of up to -300V into 50 Ohm loads. Two main outputs are provided. The two channels share a common trigger source (which can be internal or external) and common amplitude controls. The pulse width and pulse delay are independently adjustable for the two channels.

The instrument may be triggered by the internal oscillator, by a front-panel pushbutton, or by an external TTL signal. When triggered externally, the output pulse width may be controlled either by the front panel controls (EXT A trigger mode) or the output pulse width can be set to track the input pulse width (EXT B trigger mode). The pulse width and pulse delay front panel controls are inactive in the EXT B mode.

The output amplitude can be controlled by a front-panel ten-turn locking dial, or by a DC voltage applied to the rear-panel AMP input. A 0V input corresponds to an amplitude of 0V, and a +10V input corresponds to -300V, approximately. The response rate of the amplitude when controlled by this input is  $> 1$  V/ms. The maximum discharge time (i.e., in response to a input step from +10V to 0V, representing an amplitude change from -300V to 0V) is 100 ms.

This instrument is similar to the previously-supplied AVR-3-C-N-KOPA-EA instrument, with the addition of independent pulse width and delay controls. Also, the AVR-3-C-N-KOPC-EA offers longer delay settings.

## SPECIFICATIONS

Model:	AVR-3-C-N-KOPC-EA
Amplitude <sup>2</sup> : (50 $\Omega$ load)	0 to -300 Volts
Amplitude control:	By front-panel ten-turn locking dial, or by the rear-panel EA input. The two output channels share a common amplitude setting.
EA input:	Allows the amplitude to be controlled by an external voltage. A 0V input corresponds to an amplitude of 0V, and a +10V input corresponds to -300V, approximately. The response rate of the amplitude when controlled by this input is $> 1$ V/ms. The maximum discharge time (i.e., in response to a input step from +10V to 0V, representing an amplitude change from -300V to 0V) is 100 ms.
Rise time:	$\leq 15$ ns
Fall time:	$\leq 15$ ns
Pulse width:	0.1 to 1.0 $\mu$ s. Each of the two output channels has an independent pulse width control, which is active in all modes except for the $PW_{IN}=PW_{OUT}$ (EXT B) mode.
Sync delay: (Main out to SYNC out)	0.15 to 100 $\mu$ s. Each of the two output channels has an independent delay control, which is active in all modes except for the $PW_{IN}=PW_{OUT}$ (EXT B) mode.
PRF:	0 to 1 kHz. The two channels share a common trigger source.
Duty cycle (max):	0.1%
Propagation delay:	$\leq 100$ ns (Ext trig in to pulse out)
Jitter: (Ext trig in to pulse out)	$\pm 100$ ps $\pm 0.03\%$ of sync delay
Trigger required: (external trigger mode)	Mode A: + 5 Volts, 50 ns or wider (TTL) Mode B: + 5 Volts, $PW_{IN} = PW_{OUT}$ (TTL)
Sync output:	+ 3 Volts, 200 ns, will drive 50 Ohm loads
Connectors:	Out, Trig, Sync: BNC
Power requirements:	120/240 Volts (switchable) 50 - 60 Hz
Dimensions: (H x W x D)	100 mm x 430 mm x 375 mm (3.9" x 17" x 14.8")

ORIGINAL QUOTATION

June 17, 2003

To: Kevin O'Connor  
 Kopin Corp.  
 508-824-6696 x648  
 koconnor@kopin.com

Kevin,

Following our telephone conversation, I am pleased to re-quote as follows:

Quote number: 11613

Model number: AVR-3-C-N-KOPC-EA

Description: Dual-Channel High Voltage Pulser.

Delay controls: Each of the two output channels has a variable delay control, variable from 0 to 100 us. This delay feature is only active in the internal trigger mode.

Pulse width controls: Each of the two output channels has a variable pulse width control, variable from 0.1 to 1.0 us.

Other: as per the AVR-3-C-N-KOPA-EA (purchased previously by Kopin, and described in quote #11312B of Nov 26/02). The two output channels share common amplitude controls and EA inputs.

Price: \$8198 US each (qty 5), FOB destination.

Delivery: 30 days after receipt of order.

Please call or email me if I can be of further assistance.

Regards,  
 Dr. Michael J. Chudobiak  
 VP, New Product Development

--- Avtech Electrosystems Ltd. ----- since 1975 ---

PO Box 265	ph: 1-800-265-6681 or 613-226-5772	Box 5120 Stn. F
Ogdensburg, NY	fax: 1-800-561-1970 or 613-226-2802	Ottawa, Ontario
USA 13669-0265	email: info@avtechpulse.com	Canada K2C 3H4
	http://www.avtechpulse.com/	

Nanosecond Waveform Generators  
 for general purpose, R&D and OEM applications

Pulse Generators - Laser Diode Drivers - Pulse Amplifiers  
 Impulse Generators - Current Pulsers - Delay Generators - Splitters

Function Generators - Monocycle Generators - Frequency Dividers + more!

---

## INSTALLATION

### VISUAL CHECK

After unpacking the instrument, examine to ensure that it has not been damaged in shipment. Visually inspect all connectors, knobs, and handles. Confirm that a power cord and the output shorting bar are with the instrument. If the instrument has been damaged, file a claim immediately with the company that transported the instrument.

### PLUGGING IN THE INSTRUMENT

Examine the rear of the instrument. There will be a male power receptacle, a fuse holder and the edge of the power selector card visible. Confirm that the power selector card is in the correct orientation.

For AC line voltages of 110-120V, the power selector card should be installed so that the “120” marking is visible from the rear of the instrument, as shown below:



For AC line voltages of 220-240V, the power selector card should be installed so that the “240” marking is visible from the rear of the instrument, as shown below:





If it is not set for the proper voltage, remove the fuse and then grasp the card with a pair of pliers and remove it. Rotate horizontally through 180 degrees. Reinstall the card and the correct fuse.

In the 120V setting, a 0.5A slow blow fuse is required. In the 240V setting, a 0.25A slow blow fuse is required.

## FRONT PANEL CONTROLS

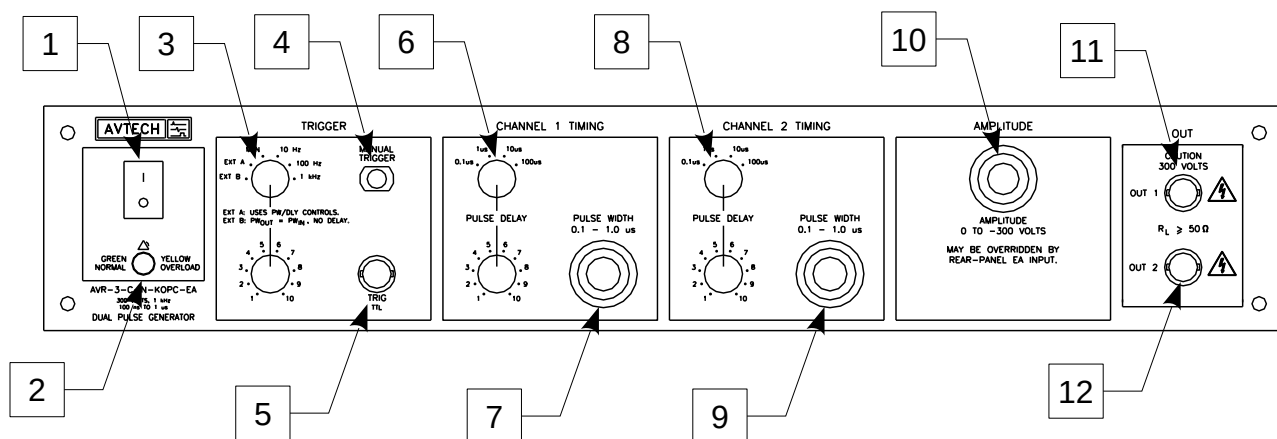

1. POWER Switch. This is the main power switch. When turning the instrument on, there may be a delay of several seconds before the instrument appears to respond.
2. OVERLOAD Indicator. When the instrument is powered, this indicator is normally green, indicating normal operation. If this indicator is yellow, an internal automatic overload protection circuit has been tripped. If the unit is overloaded (by operating at an exceedingly high duty cycle or by operating into a very low impedance), the protective circuit will disable the output of the instrument and turn the indicator light yellow. The light will stay yellow (i.e. output disabled) for about 5 seconds after which the instrument will attempt to re-enable the output (i.e. light green) for about 1 second. If the overload condition persists, the output will be disabled again (i.e. light yellow) for another 5 seconds. If the overload condition has been removed, the instrument will resume normal operation.

This overload indicator may flash yellow briefly at start-up. This is not a cause for concern.

Note that the output stage will safely withstand a short-circuited load condition.

3. TRIGGER Controls. This switch sets the triggering mode for the instrument.

In the "MAN" position, the instrument is triggered by the "Manual Trigger" pushbutton (item 4).

In the "EXT A" position the instrument is triggered by a TTL-level pulse on the TRIG connector. The pulse width and delay of the two output channels are determined by the front panel settings.

In the "EXT B" position the instrument is triggered by a TTL-level pulse on the TRIG connector. The output pulses on the two output channels occur with nominally zero

delay, and the output pulse width on each channel is approximately equal to the input pulse width.

The remaining positions serve as decade-range controls for the internal oscillator, which triggers the instrument in these positions. The vernier control immediately below the switch provides continuous adjustment of the frequency within each decade range.

4. MANUAL TRIGGER Push Button. This push button will trigger the instrument manually for one cycle of output, when the trigger mode switch is in the "MAN" position. Otherwise, the push button has no effect.
5. TRIG Connector. When the trigger mode switch is set to the "EXT A" or "EXT B" positions, a TTL-level pulse applied to this connector will trigger the instrument. The instrument triggers on the rising edge of this input. The input impedance of this input is approximately 1 kilohm. (Depending on the length of cable attached to this input, and the source driving it, it may be desirable to add a coaxial 50 Ohm terminator to this input to provide a proper transmission line termination. The Pasternack ([www.pasternack.com](http://www.pasternack.com)) PE6008-50 BNC feed-thru 50 Ohm terminator is suggested for this purpose.)

When the trigger mode switch is set to one of the other positions, this connector is used as an output that generates a 200 ns wide TTL-level pulse for each trigger event. This output can be used to trigger an oscilloscope, or other test equipment. The separation between the main output pulse and the TRIG output pulse is controlled by the DELAY controls for each channel. For this output to operate correctly, the delay setting must be less than the period.

6. CH1 DELAY Control. Controls the relative delay between the reference output pulse provided at the TRIG output and the OUT 1 output. This delay is variable over the range of 0.15 to 100 us, approximately. The TRIG output precedes the main output.
7. CH1 PW Control. This ten-turn locking dial varies the OUT 1 pulse width from 0.1 to 1 us, approximately.
8. CH2 DELAY Control. Controls the relative delay between the reference output pulse provided at the TRIG output and the OUT 2 output. This delay is variable over the range of 0.15 to 100 us, approximately. The TRIG output precedes the main output.
9. CH2 PW Control. This ten-turn locking dial varies the OUT 2 pulse width from 0.1 to 1 us, approximately.
10. AMP Control. This ten-turn locking dial varies the output pulse amplitude of both channels 1 and 2 from 0 to -300 Volts (to 50 Ohms), when the rear-panel AMP switch is in the "INT" position.
11. OUT 1 Connector. This BNC connector provides the channel 1 output, into load impedances of 50 Ohms or higher.

⚠ Caution: Voltages as high as -300V may be present on the center conductor of this output connector. Avoid touching this conductor. Connect to this connector using standard coaxial cable, to ensure that the center conductor is not exposed.

12. OUT 2 Connector. This BNC connector provides the channel 2 output, into load impedances of 50 Ohms or higher.

⚠ Caution: Voltages as high as -300V may be present on the center conductor of this output connector. Avoid touching this conductor. Connect to this connector using standard coaxial cable, to ensure that the center conductor is not exposed.

## REAR PANEL CONTROLS

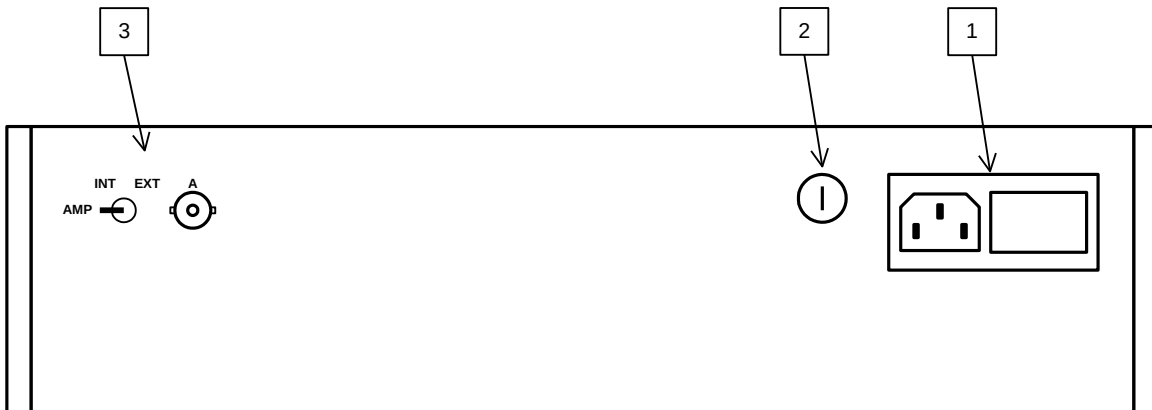

- 1) AC POWER INPUT. A three-pronged recessed male connector is provided on the back panel for AC power connection to the instrument. Also contained in this assembly is a slow blow fuse and a removable card that can be removed and repositioned to switch between 120V AC in and 240V AC in.

For AC line voltages of 110-120V, the power selector card should be installed so that the “120” marking is visible from the rear of the instrument.

For AC line voltages of 220-240V, the power selector card should be installed so that the “240” marking is visible from the rear of the instrument.

If it is not set for the proper voltage, remove the fuse and then grasp the card with a pair of pliers and remove it. Rotate horizontally through 180 degrees. Reinstall the card and the correct fuse.

In the 120V setting, a 0.5A slow blow fuse is required. In the 240V setting, a 0.25A slow blow fuse is required. See the “Installation” section for more details.

- 2) 0.8A SB. This fuse protects the internal high-voltage DC power supply.
- 3) EA SWITCH AND INPUT. When this switch is set to the “INT” position, the output amplitude is controlled by the front-panel amplitude dial. When this switch is set to the “EXT” position, the output amplitude is controlled by the voltage applied to the “A” BNC connector. A 0V input corresponds to an amplitude of 0V, and a +10V input corresponds to -300V, approximately. The response rate of the amplitude when controlled by this input is  $> 1$  V/ms. The maximum discharge time (i.e., in response to a input step from +10V to 0V, representing an amplitude change from -300V to 0V) is 100 ms.

## GENERAL INFORMATION

### TEST ARRANGEMENT

The basic test arrangement is illustrated below:

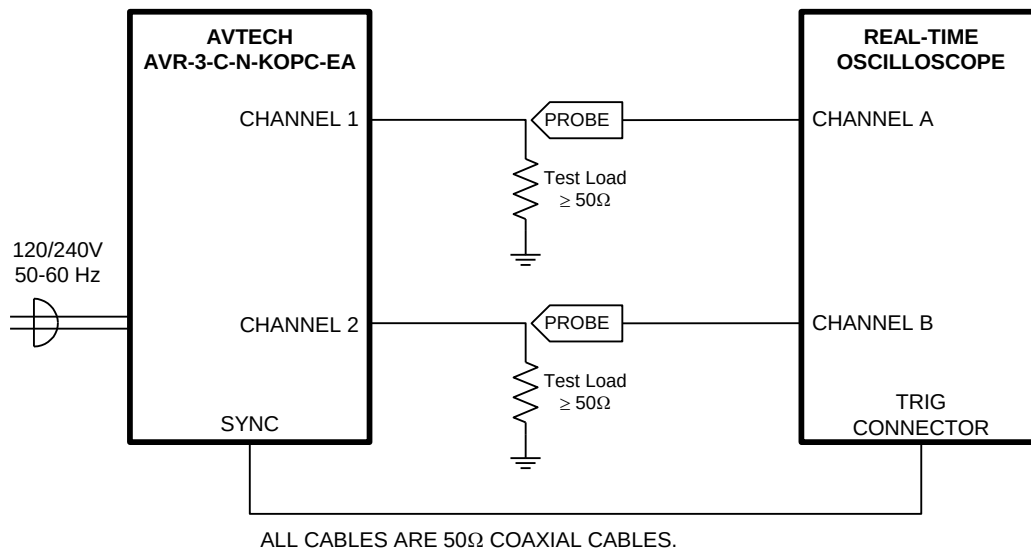

In this diagram, it is assumed that the rear-panel “AMP” switch is set to “INT”, in which case the amplitude of the two outputs is controlled by the single front-panel amplitude dial.

If an external voltage is used to control the output amplitude, the rear-panel “AMP” switch should be set to “EXT”, and the instrument should be connected as shown below:

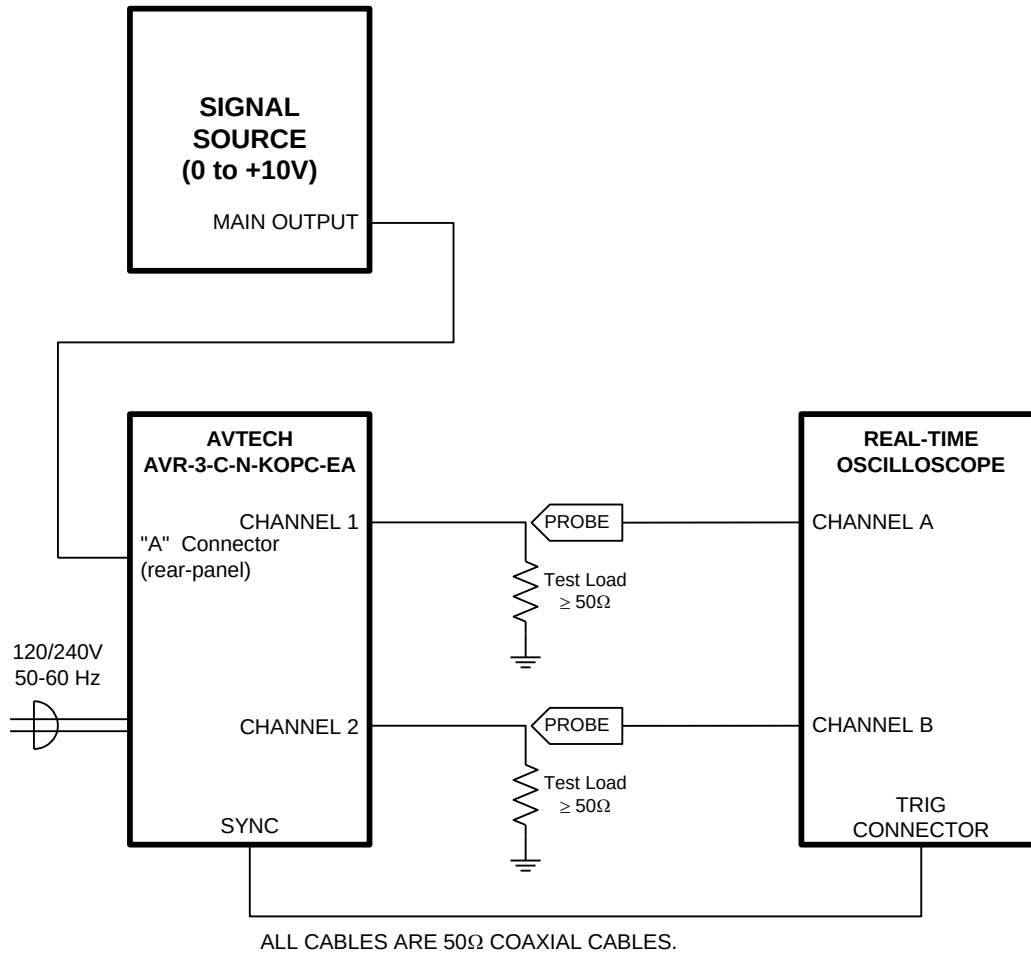

## MECHANICAL INFORMATION

### TOP COVER REMOVAL

If necessary, the interior of the instrument may be accessed by removing the four Phillips screws on the top panel. With the four screws removed, the top cover may be slid back (and off).

Always disconnect the power cord before opening the instrument.

There are no user-adjustable internal circuits. For repairs other than fuse replacement, please contact Avtech (info@avtechpulse.com) to arrange for the instrument to be returned to the factory for repair.

⚠ Caution: High voltages are present inside the instrument during normal operation. Do not operate the instrument with the cover removed.

### RACK MOUNTING

A rack mounting kit is available. The -R5 rack mount kit may be installed after first removing the one Phillips screw on the side panel adjacent to the front handle.

### ELECTROMAGNETIC INTERFERENCE

To prevent electromagnetic interference with other equipment, all used outputs should be connected to shielded 50Ω loads using shielded 50Ω coaxial cables. Unused outputs should be terminated with shielded 50Ω BNC terminators or with shielded BNC dust caps, to prevent unintentional electromagnetic radiation. All cords and cables should be less than 3m in length.



## POWER SUPPLY AND FUSE REPLACEMENT

This instrument has four main fuses, plus two spares. One, which protects the AC input, is located in the rear-panel power entry module, as described in the “Rear Panel Controls” section of this manual. If the power appears to have failed, check the AC fuse first. The second is also located on the rear panel, and protects the internal high-voltage power supply.

The other two fuses (plus two spares) are located on the internal DC power supply, as shown below:

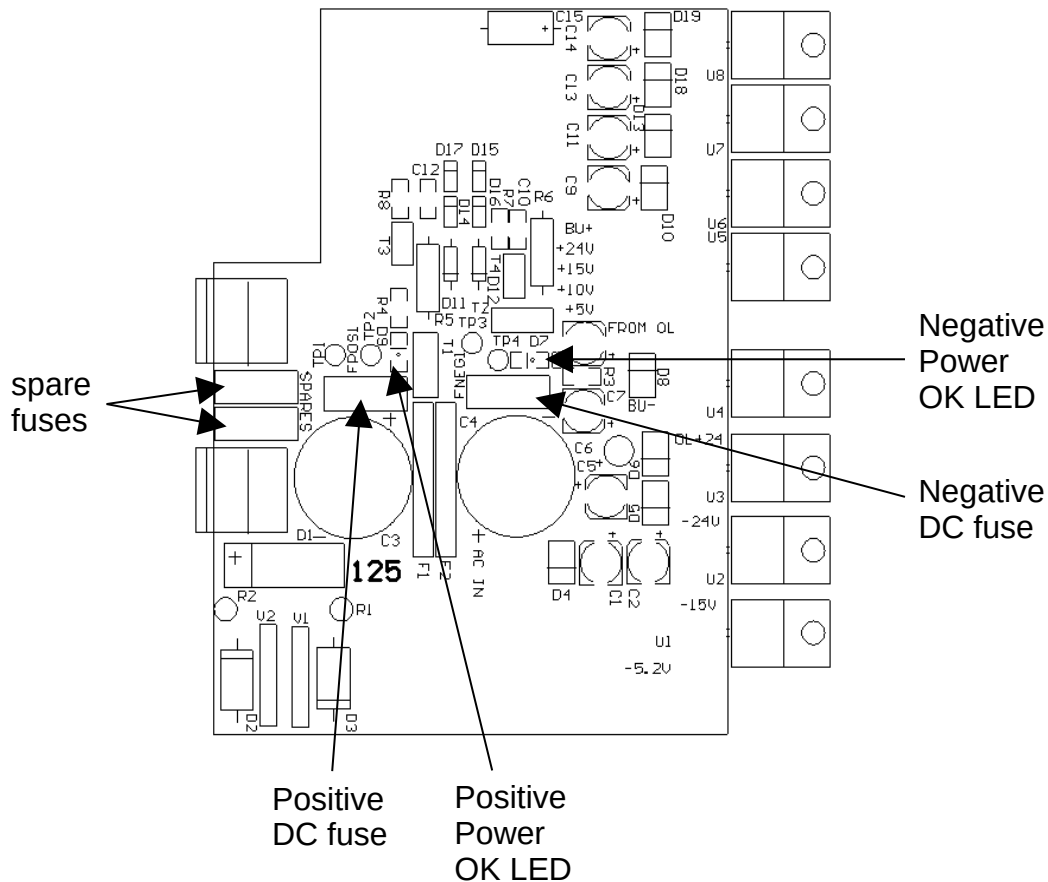

The positive fuse and one of the spare fuses on this circuit board are 1.5A slow-blow fuses, Littlefuse part number R45201.5. (This fuse can be ordered from Digikey, [www.digikey.com](http://www.digikey.com). The Digikey part number is F1344CT-ND). The negative fuse and the second spare fuse are 0.5A slow-blow fuses (Littlefuse R452.500, Digikey part number F1341CT-ND).

If you suspect that the DC fuses are blown, follow this procedure:

1. Remove the top cover, by removing the four Phillips screws on the top cover and then sliding the cover back and off.

2. Locate the two “Power OK” LEDs on the power supply circuit board, as illustrated above.
3. Turn on the instrument.
4. Observe the “Power OK” LEDs. If the fuses are not blown, the two LEDs will be lit (bright red). If one of the LEDs is not lit, the fuse next to it has blown.
5. Turn off the instrument.
6. If a fuse is blown, use needle-nose pliers to remove the blown fuse from its surface-mount holder.
7. Replace the fuse. (Spare 1.5 Amp and 0.5 Amp fuses are provided on the circuit board. They may be transferred to the active fuse locations using needle-nose pliers.)

PERFORMANCE CHECK SHEET