

INSTRUCTIONS

MODEL AVR-3-PW-C-P-TEK2 PULSE GENERATOR

S.N.:

### WARRANTY

Avtech Electrosystems Ltd. warrants products of its manufacture to be free from defects in material and workmanship under conditions of normal use. If, within one year after delivery to the original owner, and after prepaid return by the original owner, this Avtech product is found to be defective, Avtech shall at its option repair or replace said defective item. This warranty does not apply to units which have been disassembled, modified or subjected to conditions exceeding the applicable specifications or ratings. This warranty is the extent of the obligation assumed by Avtech with respect to this product and no other warranty or guarantee is either expressed or implied.

### TECHNICAL SUPPORT

Phone: 613-226-5772 or 1-800-265-6681

Fax: 613-226-2802 or 1-800-561-1970

E-mail: [info@avtechpulse.com](mailto:info@avtechpulse.com)

World Wide Web: <http://www.avtechpulse.com>



## TABLE OF CONTENTS

WARRANTY.....	2
TABLE OF CONTENTS.....	4
Manual Reference: /fileserver1/officefiles/instructword/avr-3/AVR-3-PW-C-P-TEK2edc.doc, created Oct. 24, 2000.....	5
Fig. 1: PULSE GENERATOR TEST ARRANGEMENT.....	6
THEORY OF OPERATION.....	7
Fig. 2: SHORTING BAR, ADAPTER ARRANGEMENT FOR CURRENT PROBE.....	7
GENERAL INSTRUCTIONS.....	8
Fig. 3: FRONT PANEL CONTROLS.....	11
FRONT PANEL CONTROLS.....	12
FIG. 4: BACK PANEL CONTROLS.....	15
BACK PANEL CONTROLS.....	16
TOP COVER REMOVAL AND RACK MOUNTING.....	17
FIG. 5: POWER SUPPLY.....	18
SYSTEM DESCRIPTION AND REPAIR PROCEDURE.....	19
POWER SUPPLY AND FUSE REPLACEMENT.....	20

PERFORMANCE CHECK SHEET.....22

Manual Reference: /fileserver1/officefiles/instructword/avr-3/AVR-3-PW-C-P-TEK2edc.doc, created Oct. 24, 2000

Fig. 1: PULSE GENERATOR TEST ARRANGEMENT

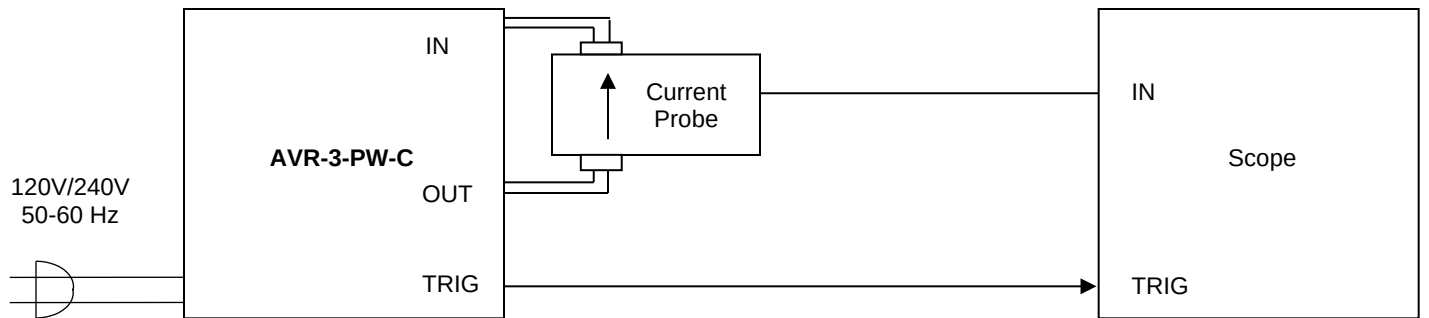

## THEORY OF OPERATION

- 1) The AVR-3-PW-C-TEK2 generates a 10 ns rise time voltage pulse (0 to +250 Volts, 0.25 to 250  $\mu$ s) which is accessible at the front panel OUT terminal. A shorting bar is connected between the OUT and IN terminals and the current probe is placed over the shorting bar. The IN terminal connects to ground via a 50 Ohm termination. A variable current of up to 5.0 Amperes is defined by the 250 Volt pulse and the 50 Ohm termination.

Fig. 2: SHORTING BAR, ADAPTER ARRANGEMENT FOR CURRENT PROBE

### GENERAL INSTRUCTIONS

- 1) The TRIG output channel provides TTL level signal. The TRIG output precedes the main output when the front panel ADVANCE-DELAY switch is in the ADVANCE position. The TRIG output lags the main output when the switch is in the DELAY position.
- 2) To obtain a stable output display the PRF control on the front panel should be set mid range. The front panel TRIG switch should be in the INT position. The DELAY controls and the scope triggering controls are then adjusted to obtain a stable output. The scope may then be used to set the desired PRF by rotating the PRF controls.
- 3) The output pulse width is controlled by means of the front panel one turn PW control and by the PW RANGE control. The minimum and maximum PW for each range and the corresponding maximum PRF are as follows. Note that the unit may fail if operated at duty cycles exceeding 0.25%.

	PW min	PW max
Range 1	0.25 $\mu$ s PRF max 10 kHz	2.5 $\mu$ s PRF max 2.5 kHz
Range 2	2.5 $\mu$ s PRF max 2.5 kHz	25 $\mu$ s PRF max 250 Hz
Range 3	25 $\mu$ s PRF max 250 Hz	250 $\mu$ s PRF max 25 Hz

- 4) The output pulse amplitude is controlled by means of the front panel ten turn AMP control. To voltage control the output amplitude, set the rear panel switch in the EXT position and apply 0 to +10 volts between the BNC connector "A" and ground ( $R_{IN} \geq 10K$ ).



- 5) An external clock may be used to control the output PRF of the AVR unit by setting the front panel TRIG toggle switch in the EXT position and applying a 50 ns (or wider) (approx.) TTL level pulse to the TRIG BNC connector input. For operation in this mode, the scope time base must also be triggered by the external clock rather than from the TRIG output. When triggered externally, the output pulse width is controlled by the front panel PW controls provided the MODE A-B switch is in the A position. When the MODE A-B switch is in the B position, the output pulse width equals the input trigger pulse width.
- 6) For single pulse manual operation, set the front panel INT-EXT-MAN switch in the MAN position and push the SINGLE PULSE button.
- 7) The DELAY control controls the relative delay between the reference output pulse provided at the TRIG output and the main output. This delay is variable over the range of 0.25  $\mu$ s to 250  $\mu$ s. The TRIG output precedes the main output when the ADVANCE-DELAY switch is in the ADVANCE position and lags when the switch is in the DELAY position.

	MIN	MAX
Range 1	0.25 $\mu$ s	2.5 $\mu$ s
Range 2	2.5 $\mu$ s	25 $\mu$ s
Range 3	25 $\mu$ s	250 $\mu$ s

- 8) AVR-3-PW-C units with a serial number higher than 5600 are protected by an automatic overload protective circuit which controls the front panel overload light. If the unit is overloaded (by operating at an exceedingly high duty cycle or by operating into a short circuit), the protective circuit will turn the output of the instrument OFF and turn the indicator light ON. The light will stay ON (i.e. output OFF) for about 5 seconds after which the instrument will attempt to turn ON (i.e. light OFF) for about 1 second. If the overload condition persists, the instrument will turn OFF again (i.e. light ON) for another 5 seconds. If the overload condition has been removed, the instrument will turn on and resume normal operation. Overload conditions may be removed by:

- 1) Reducing PRF (i.e. switch to a lower range)
- 2) Reducing pulse width (i.e. switch to a lower range)
- 3) Removing output load short circuit (if any)

- 9) A shorting bar is connected between the OUT and IN SMA connectors. The current probe is clamped over the shorting bar. Note that the current flow is from the out terminal to the IN terminal and note that the shorting bar may be at a pulsed potential as high as +250 Volts.
- 10) Large energy storage capacitors are employed in the output stage to obtain very low droop ( $\leq 2\%$ ) at very wide pulse (250  $\mu$ s). As a result of the large capacitors, the output voltage amplitude will decrease slowly when the amplitude control is rotated counter-clockwise. This effect is particular pronounced at narrow pulse widths. The delay time constant may be reduced by a factor of ten by placing the HIGH-LOW capacitor switch in the LOW position. The switch may be accessed by removing the top cover (by removing the four Phillips screws on the top cover and sliding the cover back and off).
- 11) The voltage pulse generated by the unit may be viewed by connecting a 50 Ohm terminator to the OUT SMA connector and placing a voltage probe across the terminator. Minor adjustments to the maximum output amplitude (+250 Volts) may be made by removing the top cover and making minor adjustments to the AMP 2 locking pot.
- 12) The unit can be converted from 120 to 240V 50-60 Hz operation by adjusting the voltage selector card in the rear panel fused voltage selector-cable connector assembly.
- 13) For additional information:  
  
Tel: (613) 226-5772  
Fax: (613) 226-2802  
E-mail : [info@avtechpulse.com](mailto:info@avtechpulse.com)

Fig. 3: FRONT PANEL CONTROLS

## FRONT PANEL CONTROLS

- 1) ON-OFF Switch. Applies basic prime power to all stages.
- 2) PRF Control. Varies PRF from 1 Hz to 10 kHz as follows:

1 Hz	to	10 Hz
10 Hz	to	100 Hz
100 Hz	to	1 kHz
1 kHz	to	10 kHz

- 3) DELAY Control. Controls the relative delay between the reference output pulse provided at the TRIG output (4) the main output (5). This delay is variable over the range of 0.25 to about 250  $\mu$ s. Delay LEADS or LAGS depending on the position of the ADVANCE-DELAY switch.

	MIN	MAX
Range 1	0.25 $\mu$ s	2.5 $\mu$ s
Range 2	2.5 $\mu$ s	25 $\mu$ s
Range 3	25 $\mu$ s	250 $\mu$ s

- 4) TRIG Output. This output is used to trigger the scope time base. The output is a TTL level 100 ns (approx.) pulse capable of driving a fifty ohm load. This output precedes the output at (5) if the two position ADVANCE-DELAY switch is in the ADVANCE position. This output follows the output at (5) if the switch is in the DELAY position. The delay range is variable from 0.25  $\mu$ s to 250  $\mu$ s. The external trigger signal is applied at this input when the EXT-INT toggle switch is in the EXT position.
- 5) OUT Connector. SMA connector provides 0 to +250 Volt output to a 50 Ohm load. (5) and (6) are to be connected as shown in Fig. 2.
- 6) IN Connector. SMA connection to internal 50 Ohm load. (5) and (6) are to be connected as shown in Fig. 2.

- 7) PW Control. A one turn control and 3 position range switch which varies the positive output pulse width from 0.25 us to 250 us. The minimum and maximum PW for each range and the corresponding maximum PRF are as follows. Note that the unit may fail if operated at duty cycles exceeding 0.25%.

	PW min	PW max
Range 1	0.25 us	2.5 us
	PRF max 10 kHz	PRF max 2.5 kHz
Range 2	2.5 us	25 us
	PRF max 2.5 kHz	PRF max 250 Hz
Range 3	25 us	250 us
	PRF max 250 Hz	PRF max 25 Hz

- 8) AMP Control. A ten turn control which varies the output pulse amplitude from 0 to 250 V (to 50 Ohms).
- 9A) INT-EXT-MAN Control and MODE A-B. With this toggle switch in the INT position, the PRF of the AVR unit is controlled via an internal clock which in turn is
- 9B) controlled by the PRF control. With the toggle switch in the EXT position, the AVR unit requires a 50 ns (or wider) TTL level pulse applied at the TRIG input in order to trigger the output stages. In addition, in this mode, the scope time base must be triggered by the external trigger source. When triggered externally, the output pulse width is controlled by the front panel PW controls provided the MODE A-B switch is in the A position. When the MODE A-B switch is in the B position, the output pulse width equals the input trigger pulse width.
- 10) SINGLE PULSE. For single pulse manual operation, set the front panel INT-EXT-MAN switch in the MAN position and push the SINGLE PULSE button.

11) OVERLOAD INDICATOR. AVR-3-PW-C units with a serial number higher than 5600 are protected by an automatic overload protective circuit which controls the front panel overload light. If the unit is overloaded (by operating at an exceedingly high duty cycle or by operating into a short circuit), the protective circuit will turn the output of the instrument OFF and turn the indicator light ON. The light will stay ON (i.e. output OFF) for about 5 seconds after which the instrument will attempt to turn ON (i.e. light OFF) for about 1 second. If the overload condition persists, the instrument will turn OFF again (i.e. light ON) for another 5 seconds. If the overload condition has been removed, the instrument will turn on and resume normal operation. Overload conditions may be removed by:

- 1) Reducing PRF (i.e. switch to a lower range)
- 2) Reducing pulse width (i.e. switch to a lower range)
- 3) Removing output load short circuit (if any)

FIG. 4: BACK PANEL CONTROLS

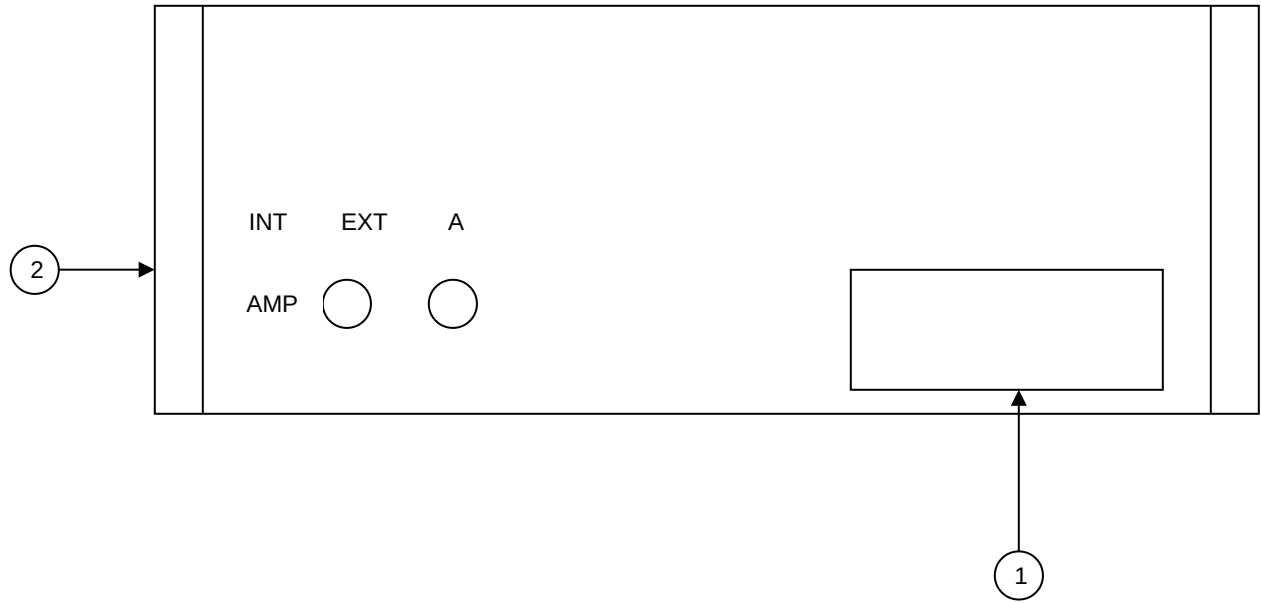

### BACK PANEL CONTROLS

- (1) FUSED CONNECTOR, VOLTAGE SELECTOR. The detachable power cord is connected at this point. In addition, the removable cord is adjusted to select the desired input operating voltage. The unit also contains the main power fuse.
- (2) EA. To voltage control the output amplitude, set the switch in the EXT position and apply 0 to +10 Volts between terminal A and ground ( $R_{IN} > 10K$ ).



### TOP COVER REMOVAL AND RACK MOUNTING

- 1) The interior of the instrument may be accessed by removing the four Phillips screws on the top panel. With the four screws removed, the top cover may be slid back (and off).
- 2) The optional R5 rack mount kit may be installed after first removing the one Phillips screw on the side panel adjacent to the front handle.

FIG. 5: POWER SUPPLY

## SYSTEM DESCRIPTION AND REPAIR PROCEDURE

The AVR-3-PW-C consists of the following basic modules:

- 1) AVR-3-PW-PG pulse generator module
- 2) AVR-3-CL clock module
- 3) +24V power supply board
- 4) AVR-3-PS power supply module
- 5) AVR-3-PW pulse width module
- 6) AVR-3-PW overload module
- 7) AVR-3-TEK2-50 internal load
- 8) AVR-3-DB2 single pulse module

The modules are interconnected as shown in Fig. 5. The clock module controls the output PRF and the relative delay between the main output and the SYNC outputs. The PG pulse generator modules generate the output pulse. The PS module generates 0 to 250 Volts to power the pulse generator module. The PW module controls the output pulse width. In the event of an instrument malfunction, it is most likely that the rear panel 1.0A SB fuse or some of the output switching elements (SL4T) may have failed due to an output short circuit condition or to a high duty cycle condition. The switching elements may be accessed by removing the cover plate on the bottom side of the instrument. NOTE: First turn off the prime power. The elements may be removed from their sockets by means of a needle nosed pliers. The SL4T is a selected VMOS power transistor in a TO 220 packages and may be checked on a curve tracer. If defective, replacement units should be ordered directly from Avtech. When replacing the SL4T switching elements, take care to insure that the short lead (of the three leads) is adjacent to the black dot on the chassis. If the switching elements are not defective, then the four Phillips screws on the back panel should be removed. The top cover may then be slid off and operation of the clock and power supply modules should be checked. The clock module is functioning properly if:

- a) 0.1  $\mu$ s TTL level outputs are observed at pins 2 and 3.
- b) The PRF of the outputs can be varied over the range of 1.0 Hz to 10 kHz using the PRF controls.
- c) The relative delay between the pin 2 and 3 outputs can be varied by at least 0.1  $\mu$ s to 100  $\mu$ s by the DELAY controls.

## POWER SUPPLY AND FUSE REPLACEMENT

This instrument has three fuses (plus one spare). One, which protects the AC input, is located in the rear-panel power entry module, as described in the “Rear Panel Controls” section of this manual. If the power appears to have failed, check the AC fuse first.

The other two fuses (plus one spare) are located on the internal DC power supply, as shown below:

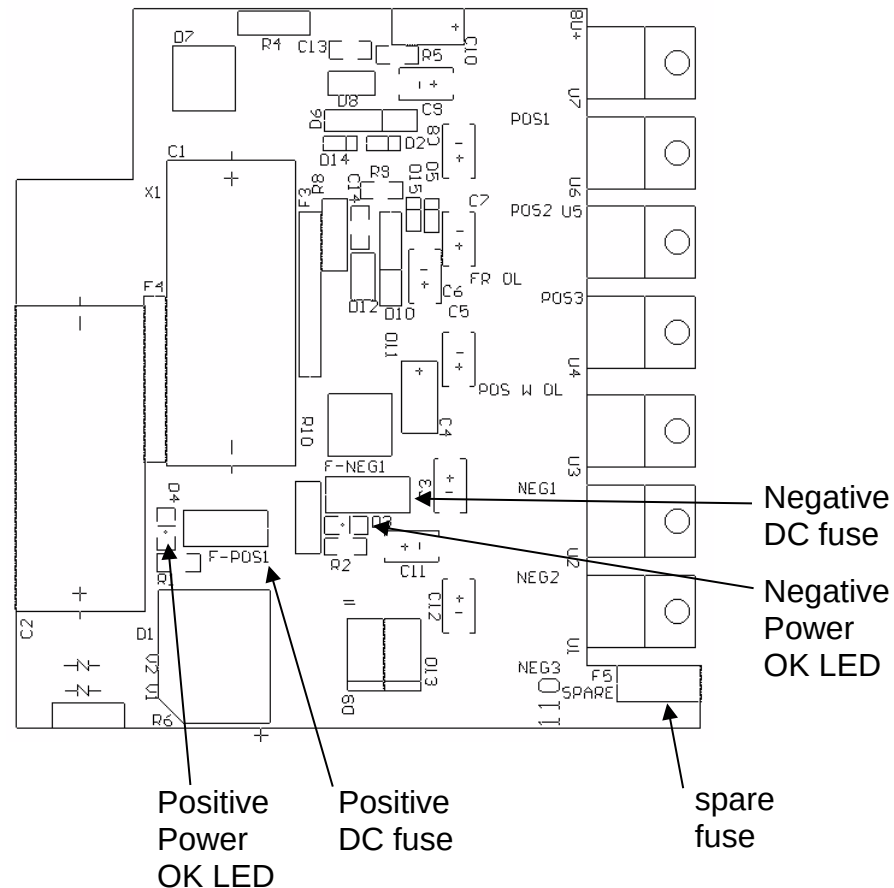

The positive fuse and the spare fuse on this circuit board are 1A slow-blow fuses, Littlefuse part number R452001. (This fuse can be ordered from Digikey, [www.digikey.com](http://www.digikey.com). The Digikey part number is F1343CT-ND). The negative fuse is a 0.5A slow-blow fuse (Littlefuse R452.500, Digikey part number F1341CT-ND).

If you suspect that the DC fuses are blown, follow this procedure:

1. Remove the top cover, by removing the four Phillips screws on the top cover and then sliding the cover back and off.

2. Locate the two “Power OK” LEDs on the power supply circuit board, as illustrated above.
3. Turn on the instrument.
4. Observe the “Power OK” LEDs. If the fuses are not blown, the two LEDs will be lit (bright red). If one of the LEDs is not lit, the fuse next to it has blown.
5. Turn off the instrument.
6. If a fuse is blown, use needle-nose pliers to remove the blown fuse from its surface-mount holder.
7. Replace the fuse.

PERFORMANCE CHECK SHEET