



AVTECH ELECTROSYSTEMS LTD.

NANOSECOND WAVEFORM ELECTRONICS
SINCE 1975

info@avtechpulse.com
http://www.avtechpulse.com/

Tel: 888-670-8729 (USA & Canada) or +1-613-686-6675 (Intl)
Fax: 800-561-1970 (USA & Canada) or +1-613-686-6679 (Intl)

BOX 5120, LCD MERIVALE
OTTAWA, CANADA K2C3H5

INSTRUCTIONS

MODEL AVR-3-PW-C-P-TEK2

+250 VOLT, +5 AMP

PULSE GENERATOR FOR

CURRENT PROBE TESTING

SERIAL NUMBER: 14043

WARRANTY

Avtech Electrosystems Ltd. warrants products of its manufacture to be free from defects in material and workmanship under conditions of normal use. If, within one year after delivery to the original owner, and after prepaid return by the original owner, this Avtech product is found to be defective, Avtech shall at its option repair or replace said defective item. This warranty does not apply to units which have been disassembled, modified or subjected to conditions exceeding the applicable specifications or ratings. This warranty is the extent of the obligation assumed by Avtech with respect to this product and no other warranty or guarantee is either expressed or implied.

TECHNICAL SUPPORT

Phone: 888-670-8729 (USA & Canada) or +1-613-686-6675 (International)

Fax: 800-561-1970 (USA & Canada) or +1-613-686-6679 (International)

E-mail: info@avtechpulse.com

World Wide Web: <http://www.avtechpulse.com>

TABLE OF CONTENTS

WARRANTY.....	2
TECHNICAL SUPPORT.....	2
TABLE OF CONTENTS.....	3
INTRODUCTION.....	5
SPECIFICATIONS.....	5
REGULATORY NOTES.....	6
FCC PART 18.....	6
EC DECLARATION OF CONFORMITY.....	6
DIRECTIVE 2011/65/EU (RoHS).....	7
DIRECTIVE 2002/96/EC (WEEE).....	7
INSTALLATION.....	9
VISUAL CHECK.....	9
POWER RATINGS.....	9
CONNECTION TO THE POWER SUPPLY.....	9
PROTECTION FROM ELECTRIC SHOCK.....	10
ENVIRONMENTAL CONDITIONS.....	11
FUSES.....	12
AC FUSE REPLACEMENT.....	12
DC FUSE REPLACEMENT.....	13
FUSE RATINGS.....	13
FRONT PANEL CONTROLS.....	14
REAR PANEL CONTROLS.....	17
GENERAL INFORMATION.....	18
TEST ARRANGEMENT.....	18
SHORTING BAR.....	18
MECHANICAL INFORMATION.....	20
TOP COVER REMOVAL.....	20
ELECTROMAGNETIC INTERFERENCE.....	20
MAINTENANCE.....	21
REGULAR MAINTENANCE.....	21
CLEANING.....	21
WIRING DIAGRAMS.....	22
WIRING OF AC POWER.....	22

PCB 158G - LOW VOLTAGE POWER SUPPLY, 1/3.....23
PCB 158G - LOW VOLTAGE POWER SUPPLY, 2/3.....24
PCB 158G - LOW VOLTAGE POWER SUPPLY, 3/3.....25
PCB 157C - HIGH VOLTAGE DC POWER SUPPLY.....26
PCB 152B - OSCILLATOR AND TRIGGER CIRCUIT, 1/2.....27
PCB 152B - OSCILLATOR AND TRIGGER CIRCUIT, 2/2.....28
PCB 216E - OP AMP BUFFERS.....29
MAIN WIRING.....30
PERFORMANCE CHECK SHEET.....31

Manual Reference: /files/officefiles/instructword/avr-3/AVR-3-PW-C-P-TEK2edk.odt.
Last modified February 29, 2024.
Copyright © 2024 Avtech Electrosystems Ltd, All Rights Reserved.

INTRODUCTION

The AVR-3-PW-C-P-TEK2 series is specifically designed for testing Tektronix current probes. The main output provides 10 ns rise time voltage pulses (up to 250V, 250 ns to 250 us), suitable for testing A6303 or TCP303 probes. A 50Ω termination is provided inside the instrument. A variable current of up to 5 Amperes is defined by the 250 Volt pulse and the 50Ω termination. For other applications, the output pulse may be connected to a user-supplied 50Ω load, if desired.

This instrument is intended for use in research and development laboratories.

SPECIFICATIONS

Model:	AVR-3-PW-TEK2-C ¹
Basic Description:	High current pulser, no GPIB / RS-232
Number of Outputs:	1
Amplitude ($R_L \geq 50 \Omega$) ^{2,3} :	10 to 250 V
Provided termination:	50.0Ω ± 1%
Voltage rise & fall times:	≤ 10 ns (20%-80%)
Pulse width (FWHM):	250 ns to 250 us
Droop (at max. pulse width):	≤ 2%
Overshoot (at max. amp.):	≤ 5%
PRF:	Internal trigger: 1 Hz to 10 kHz, External trigger: 0 Hz to 10 kHz
Duty cycle (max):	0.25%
Polarity ⁴ :	Positive or negative (specify)
Propagation delay:	≤ 150 ns (Ext trig in to pulse out)
Jitter:	± 100 ps ± 0.03% of sync delay (Ext trig in to pulse out)
Output connector:	SMA
Probe attachment style:	Rigid clamping bar on front panel.
Trigger modes:	Internal trigger, external trigger (TTL level pulse, > 50 ns, 1 kΩ input impedance), front-panel "Single Pulse" pushbutton
Variable delay: (Sync to main out)	0 to 250 us, for internal trigger mode only. No variable delay in external trigger mode.
Sync output (will drive 50Ω):	+3 Volts, 200 ns
Settings resolution:	N/A, analog controls
Settings accuracy:	Amplitude: ± 3% ± 1V, based on graduated dial markings. Timing: uncalibrated controls
Power requirements:	100 - 240 Volts, 50 - 60 Hz
Dimensions:	100 mm x 430 mm x 375 mm (3.9" x 17" x 14.8")
Mounting:	Any. Add -R5 to the model number to add a rack-mount kit.
Temperature range:	+5°C to +40°C

- 1) -C suffix indicates stand-alone lab instrument with internal clock and line powering. (See <http://www.avtechpulse.com/formats> for the basic instrument formats). Not recommended for new designs. Use -B versions instead.
- 2) For operation at amplitudes of less than 10% of full-scale, best results will be obtained by setting the amplitude near full-scale and using external attenuators on the output.
- 3) The amplitude of the AVR-3-PW-TEK2-C may also be controlled by a 0 to +10V DC voltage applied to a rear-panel BNC connector, in addition to the standard front-panel controls.
- 4) Indicate desired polarity by suffixing model number with -P or -N (i.e. positive or negative).

REGULATORY NOTES

FCC PART 18

This device complies with part 18 of the FCC rules for non-consumer industrial, scientific and medical (ISM) equipment.

This instrument is enclosed in a rugged metal chassis and uses a filtered power entry module (where applicable). The main output signal is provided on a shielded connector that is intended to be used with shielded coaxial cabling and a shielded load. Under these conditions, the interference potential of this instrument is low.

If interference is observed, check that appropriate well-shielded cabling is used on the output connectors. Contact Avtech (info@avtechpulse.com) for advice if you are unsure of the most appropriate cabling. Also, check that your load is adequately shielded. It may be necessary to enclose the load in a metal enclosure.

If any of the connectors on the instrument are unused, they should be covered with shielded metal "dust caps" to reduce the interference potential.

This instrument does not normally require regular maintenance to minimize interference potential. However, if loose hardware or connectors are noted, they should be tightened. Contact Avtech (info@avtechpulse.com) if you require assistance.

EC DECLARATION OF CONFORMITY



We Avtech Electrosystems Ltd.
 P.O. Box 5120, LCD Merivale
 Ottawa, Ontario
 Canada K2C 3H5

declare that this pulse generator meets the intent of Directive 2004/108/EG for Electromagnetic Compatibility. Compliance pertains to the following specifications as listed in the official Journal of the European Communities:

EN 50081-1 Emission

EN 50082-1 Immunity

and that this pulse generator meets the intent of the Low Voltage Directive 2006/95/EC. Compliance pertains to the following specifications as listed in the official Journal of the European Communities:

EN 61010-1:2001 Safety requirements for electrical equipment for measurement, control, and laboratory use

DIRECTIVE 2011/65/EU (RoHS)

We Avtech Electrosystems Ltd.
P.O. Box 5120, LCD Merivale
Ottawa, Ontario
Canada K2C 3H5

declare that, to the best of our knowledge, all electrical and electronic equipment (EEE) sold by the company are in compliance with Directive 2011/65/EU of the European Parliament and of the Council of 8 June 2011 on the restriction of the use of certain hazardous substances in electrical and electronic equipment (also known as “RoHS Recast”). In addition, this declaration of conformity is issued under the sole responsibility of Avtech Electrosystems Ltd. Specifically, products manufactured do not contain the substances listed in the table below in concentrations greater than the listed maximum value.

<i>Material/Substance</i>	<i>Threshold level</i>
Lead (Pb)	< 1000 ppm (0.1% by mass)
Mercury (Hg)	< 1000 ppm (0.1% by mass)
Hexavalent Chromium (Cr6+)	< 1000 ppm (0.1% by mass)
Polybrominated Biphenyls (PBB)	< 1000 ppm (0.1% by mass)
Polybrominated Diphenyl ethers (PBDE)	< 1000 ppm (0.1% by mass)
Cadmium (Cd)	< 100 ppm (0.01% by mass)
Bis(2-ethylhexyl) phthalate (DEHP)	< 1000 ppm (0.1% by mass)
Butyl benzyl phthalate (BBP)	< 1000 ppm (0.1% by mass)
Dibutyl phthalate (DBP)	< 1000 ppm (0.1% by mass)
Diisobutyl phthalate (DIBP)	< 1000 ppm (0.1% by mass)

DIRECTIVE 2002/96/EC (WEEE)

European customers who have purchased this equipment directly from Avtech will have completed a “WEEE Responsibility Agreement” form, accepting responsibility for WEEE compliance (as mandated in Directive 2002/96/EC of the European Union and local

laws) on behalf of the customer, as provided for under Article 9 of Directive 2002/96/EC.

Customers who have purchased Avtech equipment through local representatives should consult with the representative to determine who has responsibility for WEEE compliance. Normally, such responsibilities will lie with the representative, unless other arrangements (under Article 9) have been made.

Requirements for WEEE compliance may include registration of products with local governments, reporting of recycling activities to local governments, and financing of recycling activities.

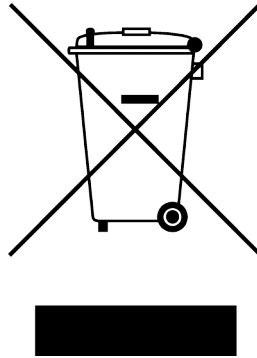

INSTALLATION

VISUAL CHECK

After unpacking the instrument mainframe and the transformer module, examine to ensure that they have not been damaged in shipment. Visually inspect all connectors, knobs, and handles. Confirm that a power cord and an instrumentation manual (this manual), are with the instrument. If the instrument has been damaged, file a claim immediately with the company that transported the instrument.

POWER RATINGS

This instrument is intended to operate from 100 - 240 V, 50 - 60 Hz.

The maximum power consumption is 57 Watts. Please see the “FUSES” section for information about the appropriate AC and DC fuses.

This instrument is an “Installation Category II” instrument, intended for operation from a normal single-phase supply.

CONNECTION TO THE POWER SUPPLY

An IEC-320 three-pronged recessed male socket is provided on the back panel for AC power connection to the instrument. One end of the detachable power cord that is supplied with the instrument plugs into this socket. The other end of the detachable power cord plugs into the local mains supply. Use only the cable supplied with the instrument. The mains supply must be earthed, and the cord used to connect the instrument to the mains supply must provide an earth connection. (The supplied cord does this.)

 Warning: Failure to use a grounded outlet may result in injury or death due to electric shock. This product uses a power cord with a ground connection. It must be connected to a properly grounded outlet. The instrument chassis is connected to the ground wire in the power cord.

The table below describes the power cord that is normally supplied with this instrument, depending on the destination region:

Destination Region	Description	Option	Manufacturer	Part Number
United Kingdom, Hong Kong, Singapore, Malaysia	BS 1363, 230V, 50 Hz	-AC00	Qualtek	370001-E01
Australia, New Zealand	AS 3112:2000, 230-240V, 50 Hz	-AC01	Qualtek	374003-A01
Continental Europe, Korea, Indonesia, Russia	European CEE 7/7 "Schuko" 230V, 50 Hz	-AC02	Qualtek	364002-D01
North America, Taiwan	NEMA 5-15, 120V, 60 Hz	-AC03	Qualtek	312007-01
Switzerland	SEV 1011, 230V, 50 Hz	-AC06	Qualtek	378001-E01
South Africa, India	SABS 164-1, 220-250V, 50 Hz	-AC17	Volex	2131H 10 C3
Japan	JIS 8303, 100V, 50-60 Hz	-AC18	Qualtek	397002-01
Israel	SI 32, 220V, 50 Hz	-AC19	Qualtek	398001-01
China	GB 1002-1 / 2099-1, 220V, 50 Hz	-AC22	Qualtek	399012-01

PROTECTION FROM ELECTRIC SHOCK

 Operators of this instrument must be protected from electric shock at all times. The owner must ensure that operators are prevented access and/or are insulated from every connection point. In some cases, connections must be exposed to potential human contact. Operators must be trained to protect themselves from the risk of electric shock. This instrument is intended for use by qualified personnel who recognize shock hazards and are familiar with safety precautions required to avoid possibly injury. In particular, operators should:

1. Keep exposed high-voltage wiring to an absolute minimum.
2. Wherever possible, use shielded connectors and cabling.
3. Connect and disconnect loads and cables only when the instrument is turned off.
4. Keep in mind that all cables, connectors, oscilloscope probes, and loads must have an appropriate voltage rating.
5. Do not attempt any repairs on the instrument, beyond the fuse replacement procedures described in this manual. Contact Avtech technical support (see page 2 for contact information) if the instrument requires servicing. Service is to be performed solely by qualified service personnel.

ENVIRONMENTAL CONDITIONS

This instrument is intended for use under the following conditions:

1. indoor use;
2. altitude up to 2 000 m;
3. temperature 5 °C to 40 °C;
4. maximum relative humidity 80 % for temperatures up to 31 °C decreasing linearly to 50 % relative humidity at 40 °C;
5. Mains supply voltage fluctuations up to ± 10 % of the nominal voltage;
6. no pollution or only dry, non-conductive pollution.

FUSES

This instrument contains four fuses. All are accessible from the rear-panel. Two protect the AC prime power input, and two protect the internal DC power supplies. The locations of the fuses on the rear panel are shown in the figure below:

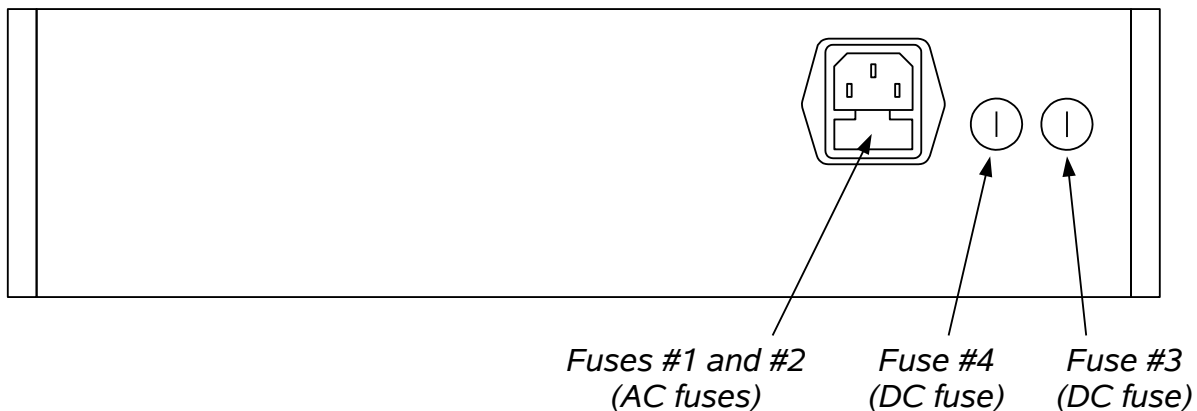

AC FUSE REPLACEMENT

To physically access the AC fuses, the power cord must be detached from the rear panel of the instrument. The fuse drawer may then be extracted using a small flat-head screwdriver, as shown below:

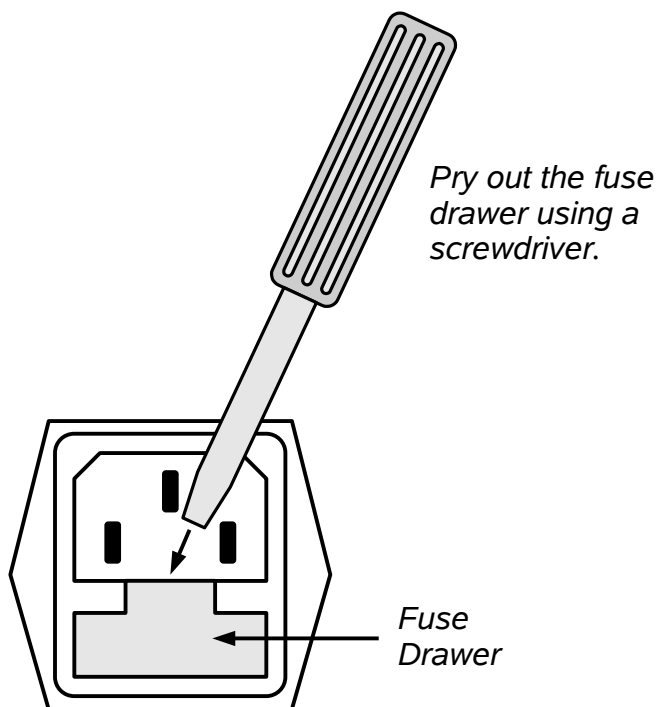

DC FUSE REPLACEMENT

The DC fuses may be replaced by inserting the tip of a flat-head screwdriver into the fuse holder slot, and rotating the slot counter-clockwise. The fuse and its carrier will then pop out.

FUSE RATINGS

The following table lists the required fuses:

Fuses	Nominal Mains Voltage	Rating	Case Size	Recommended Replacement Part	
				Littelfuse Part Number	Digi-Key Stock Number
#1, #2 (AC)	100-240V	0.5A, 250V, Time-Delay	5×20 mm	0218.500HXP	F2416-ND
#3 (DC)	N/A	1.6A, 250V, Time-Delay	5×20 mm	021801.6HXP	F2424-ND
#4 (DC)	N/A	1A, 250V, Time-Delay	5×20 mm	0218001.HXP	F2419-ND

The recommended fuse manufacturer is Littelfuse (<http://www.littelfuse.com>).

Replacement fuses may be easily obtained from Digi-Key (<http://www.digikey.com>) and other distributors.

FRONT PANEL CONTROLS

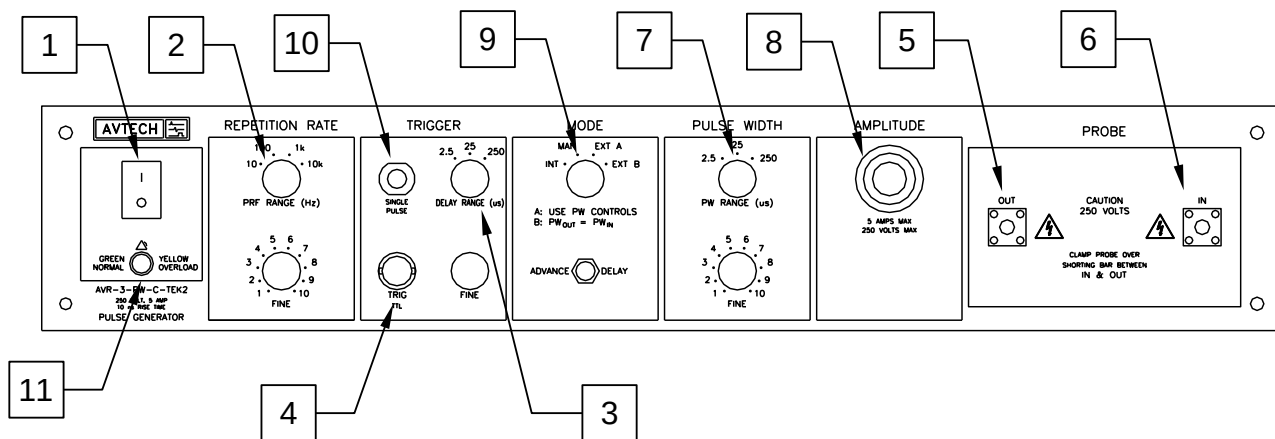

- 1. POWER Switch.** This is the main power switch. When turning the instrument on, there may be a delay of several seconds before the instrument appears to respond.
- 2. REPETITION RATE Controls.** When triggering internally, the range switch sets the pulse repetition frequency of the internal oscillator to one of four range:

RANGE 1	1 Hz - 10 Hz
RANGE 2	10 Hz - 100 Hz
RANGE 3	100 Hz - 1 kHz
RANGE 4	1 kHz - 10 kHz

The “FINE” knob varies the frequency within each range.

- 3. DELAY Control.** Controls the relative delay between the reference output pulse provided at the TRIG output (4) and the main output (5). This delay is variable over the range of 0.25 to 250 us. The TRIG output precedes the main output when the ADVANCE-DELAY switch is in the ADVANCE position and lags when the switch is in the DELAY position.
- 4. TRIG Connector.** When the MODE switch (item 9) is set to the “EXT” position, a TTL-level pulse applied to this connector will trigger the instrument. The instrument triggers on the rising edge of this input. The input impedance of this input is 1 k Ω . (Depending on the length of cable attached to this input, and the source driving it, it may be desirable to add a coaxial 50 Ohm terminator to this input to provide a proper transmission line termination. The Pasternack (www.pasternack.com) PE6008-50 BNC feed-thru 50 Ohm terminator is suggested for this purpose.)

When the MODE switch (item 8) is set to the “INT” position, this connector is

used as an output that generates a 200 ns wide TTL-level pulse for each trigger event. This output can be used to trigger an oscilloscope, or other test equipment. The separation between the main output pulse and the TRIG output pulse is controlled by the DELAY controls and the ADVANCE/DELAY switch. For this output to operate correctly, the delay setting must be less than the period.

5. OUT Connector. SMA connector provides 0 to +250 Volt output to a 50-Ohm load. (5) and (6) are normally connected together via the shorting bar, as discussed in later sections of this manual.

 Caution: Voltages as high as +250V may be present on the center conductor of this connector. Avoid touching this conductor. The center conductor is not user-accessible when the supplied shorting bar is installed.

6. IN Connector. This SMA input connects to the internal 50-Ohm load. (5) and (6) are normally connected together via the shorting bar, as discussed in later sections of this manual.

 Caution: Voltages as high as +250V may be present on the center conductor of this connector. Avoid touching this conductor. The center conductor is not user-accessible when the supplied shorting bar is installed.

7. PW Control. A one-turn knob and three-position range switch vary the output pulse width from 0.25 us to 250 us. When adjusting the pulse width, take care to keep the duty cycle below the maximum specified value of 0.25%.
8. AMP Control. This ten-turn locking dial varies the output pulse amplitude from 0 to +250 Volts (to 50 Ohms).
9. INT/MAN/EXT A/EXT B Mode Switch. With this switch in the INT position, the repetition rate of the unit is controlled by an internal oscillator, which in turn is controlled by the REPETITION RATE controls.

With the switch in the EXT A position, the unit requires a 50 ns (or wider) TTL level pulse applied at the TRIG input in order to trigger the output stages. The output pulse width is set by the front-panel controls in this mode.

With the switch in the EXT B position, the unit requires a 0.25-250 us wide TTL level pulse applied at the TRIG input in order to trigger the output stages. The output pulse width is equal to the input pulse width in this mode.

For a single pulse output, the switch should be in the “MAN” position and then push the SINGLE PULSE pushbutton (10).

10. SINGLE PULSE Pushbutton. When the INT/MAN/EXT A/EXT B switch is in the “MAN” position, the instrument can be triggered by pressing this pushbutton. A

single pulse is generated for each button press.

11. OVERLOAD Indicator. When the instrument is powered, this indicator is normally green, indicating normal operation. If this indicator is yellow, an internal automatic overload protection circuit has been tripped. If the unit is overloaded (by operating at an exceedingly high duty cycle or by operating into a very low impedance), the protective circuit will disable the output of the instrument and turn the indicator light yellow. The light will stay yellow (i.e. output disabled) for about 5 seconds after which the instrument will attempt to re-enable the output (i.e. light green) for about 1 second. If the overload condition persists, the output will be disabled again (i.e. light yellow) for another 5 seconds. If the overload condition has been removed, the instrument will resume normal operation.

This overload indicator may flash yellow briefly at start-up. This is not a cause for concern.

Overload conditions may be removed by:

- Reducing repetition rate
- Reducing pulse width
- Increasing the load impedance
- Reducing the output amplitude

REAR PANEL CONTROLS

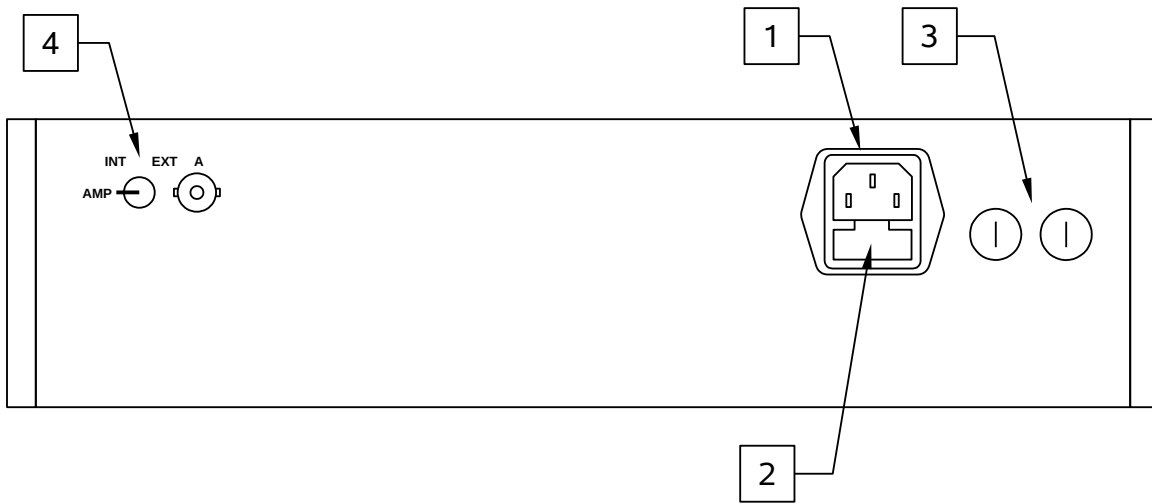

1. AC POWER INPUT. An IEC-320 C14 three-pronged recessed male socket is provided on the back panel for AC power connection to the instrument. One end of the detachable power cord that is supplied with the instrument plugs into this socket.
2. AC FUSE DRAWER. The two fuses that protect the AC input are located in this drawer. Please see the “FUSES” section of this manual for more information.
3. DC FUSES. These two fuses protect the internal DC power supplies. Please see the “FUSES” sections of this manual for more information.
4. EA SWITCH AND INPUT. When this switch is set to the “INT” position, the output amplitude is controlled by the front-panel amplitude dial. When this switch is set to the “EXT” position, the output amplitude is controlled by the voltage applied to the “A” BNC connector. 0V in corresponds to zero amplitude, and +10V DC in corresponds to maximum amplitude (+250V). The input impedance of the “A” connector is $> 10\text{ k}\Omega$.

GENERAL INFORMATION

TEST ARRANGEMENT

The AVR-3-PW-C-TEK2 generates a 10 ns rise time voltage pulse (0 to +250 Volts, 0.25 to 250 μ s), which is accessible at the front panel OUT terminal. A shorting bar is connected between the OUT and IN terminals and the current probe is placed over the shorting bar. The IN terminal connects to ground via a 50 Ohm termination. A variable current of up to 5.0 Amperes is defined by the 250 Volt pulse and the 50-Ohm termination. The basic test arrangement is illustrated below:

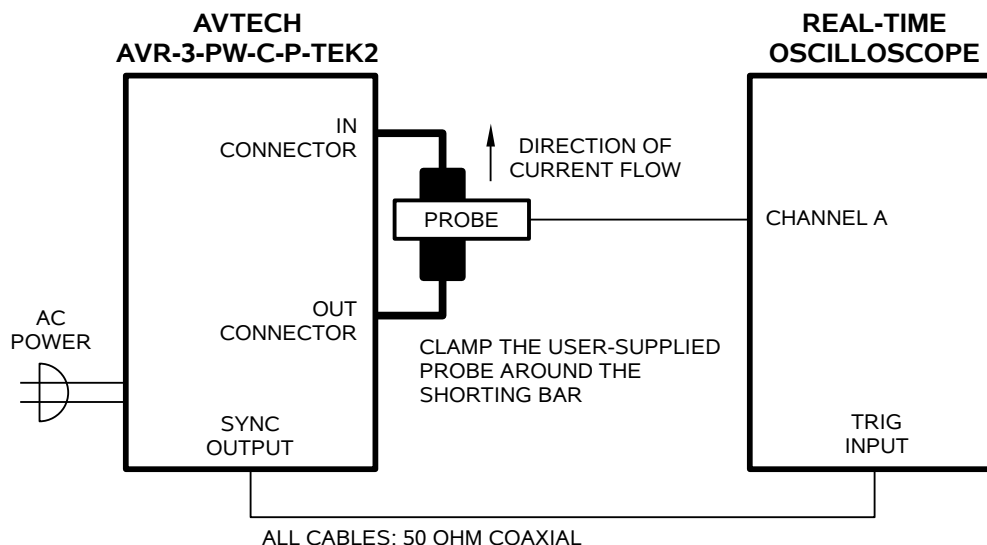

For other applications, the OUT terminal may be used to pulse a user-supplied 50 Ohm load, if desired. In this case, the shorting bar and the “IN” terminal are not used.

SHORTING BAR

The shorting bar allows a Tektronix current probe to be clamped around it. The current bar is reversible; it may be installed in either orientation. A photo of the shorting bar is shown below:



The next photo shows the shorting bar installed, with a Tektronix A6303 current probe clamped to it. Note that the probe is upside-down, in order for the probe to sense a positive current.



MECHANICAL INFORMATION

TOP COVER REMOVAL

If necessary, the interior of the instrument may be accessed by removing the four Phillips screws on the top panel. With the four screws removed, the top cover may be slid back (and off).

 Always disconnect the power cord and allow the instrument to sit unpowered for 10 minutes before opening the instrument. This will allow any internal stored charge to discharge.

There are no user-adjustable internal circuits. For repairs other than fuse replacement, please contact Avtech (info@avtechpulse.com) to arrange for the instrument to be returned to the factory for repair. Service is to be performed solely by qualified service personnel.

 Caution: High voltages are present inside the instrument during normal operation. Do not operate the instrument with the cover removed.

ELECTROMAGNETIC INTERFERENCE

To prevent electromagnetic interference with other equipment, all used outputs should be connected to shielded loads using shielded coaxial cables. Unused outputs should be terminated with shielded coaxial terminators or with shielded coaxial dust caps, to prevent unintentional electromagnetic radiation. All cords and cables should be less than 3m in length.

MAINTENANCE

REGULAR MAINTENANCE

This instrument does not require any regular maintenance.

On occasion, one or more of the four rear-panel fuses may require replacement. All fuses can be accessed from the rear panel. See the “FUSES” section for details.

CLEANING

If desired, the interior of the instrument may be cleaned using compressed air to dislodge any accumulated dust. (See the “TOP COVER REMOVAL” section for instructions on accessing the interior.) No other cleaning is recommended.

PCB 158G - LOW VOLTAGE POWER SUPPLY, 1/3

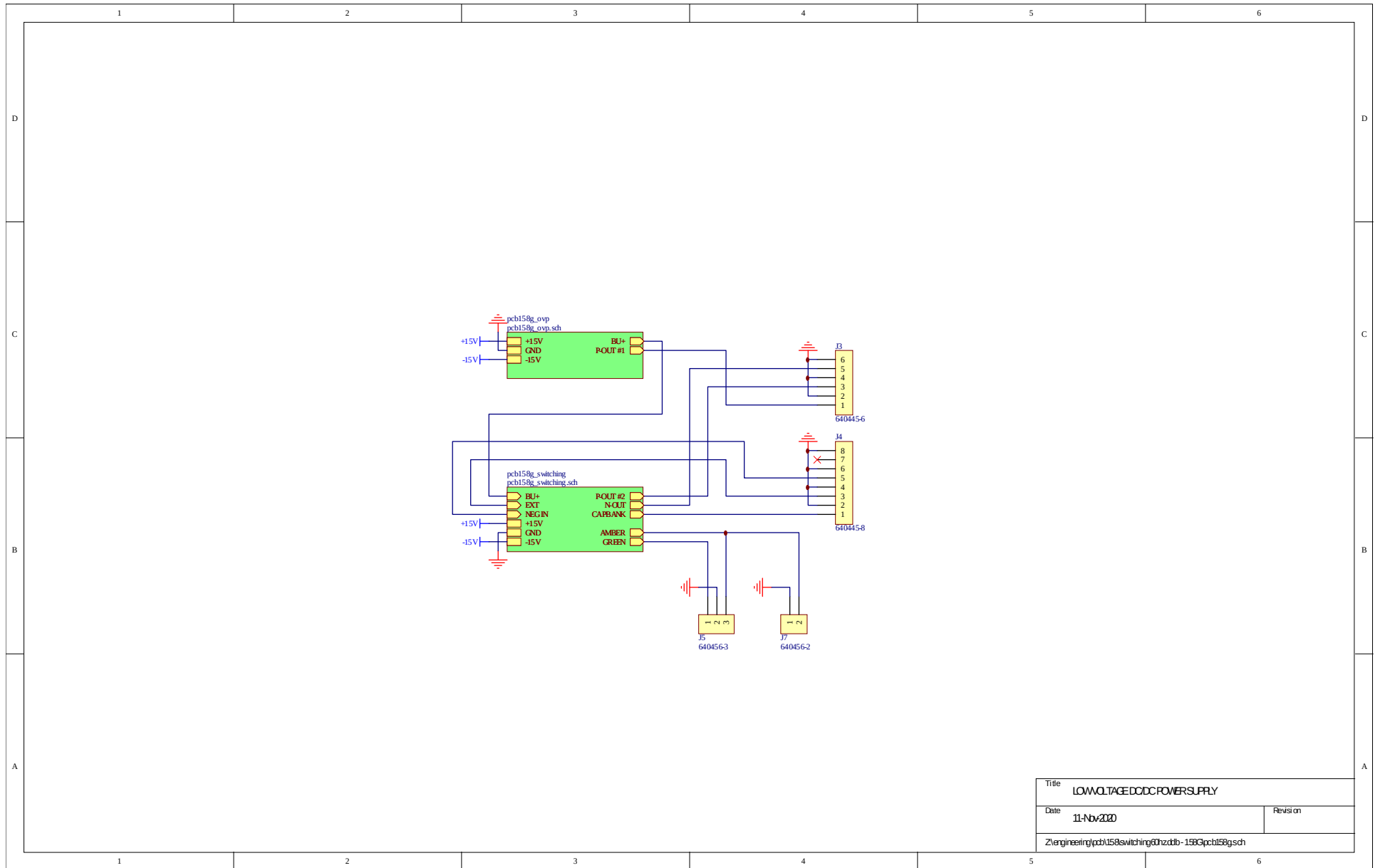

Title		LOW VOLTAGE DCDC POWER SUPPLY
Date	11-Nov-2020	Revision
Z:\engineering\pcb158g\switching\01hzddb-158Q\pcb158g.sch		

PCB 158G - LOW VOLTAGE POWER SUPPLY, 2/3

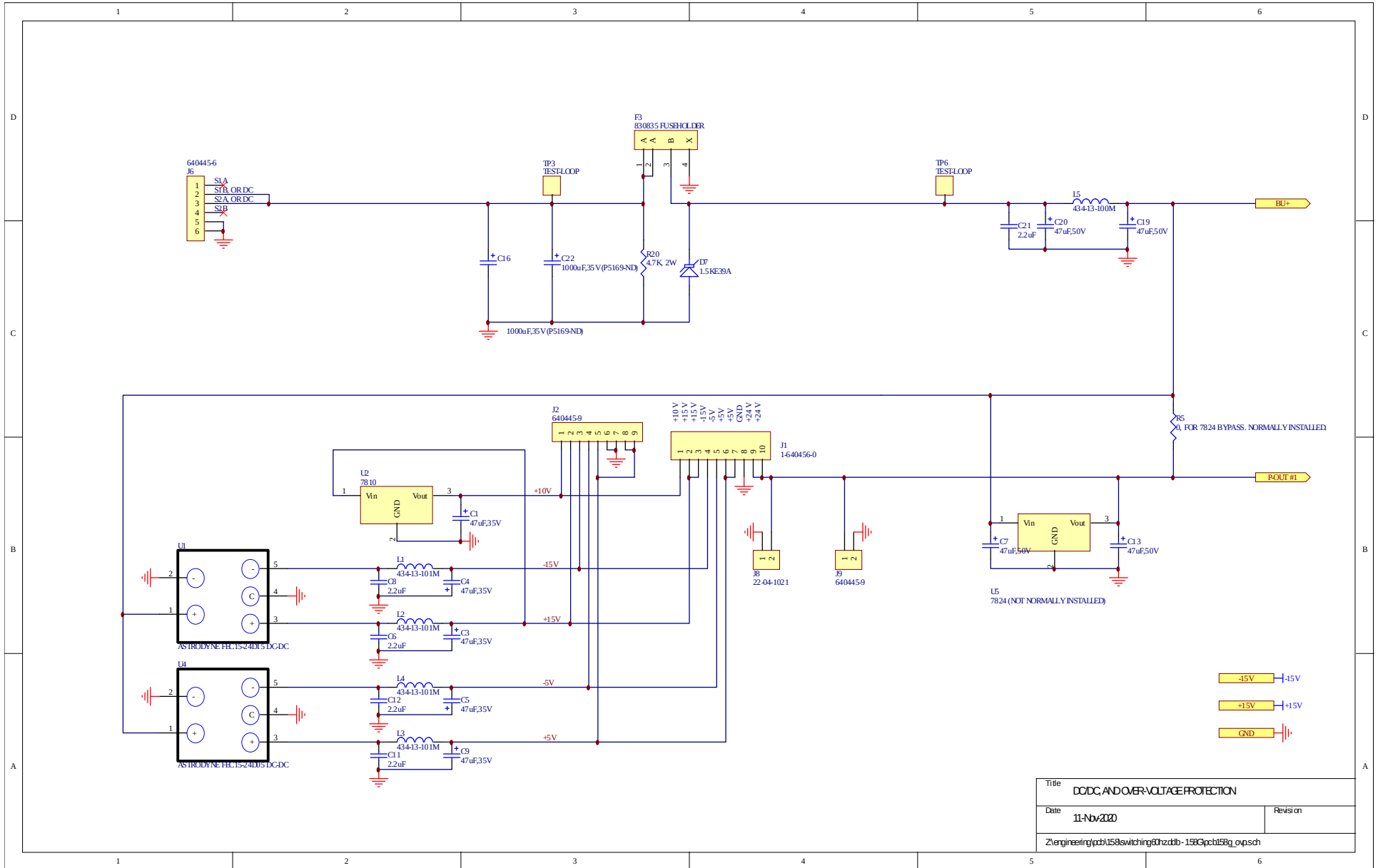

PCB 158G - LOW VOLTAGE POWER SUPPLY, 3/3

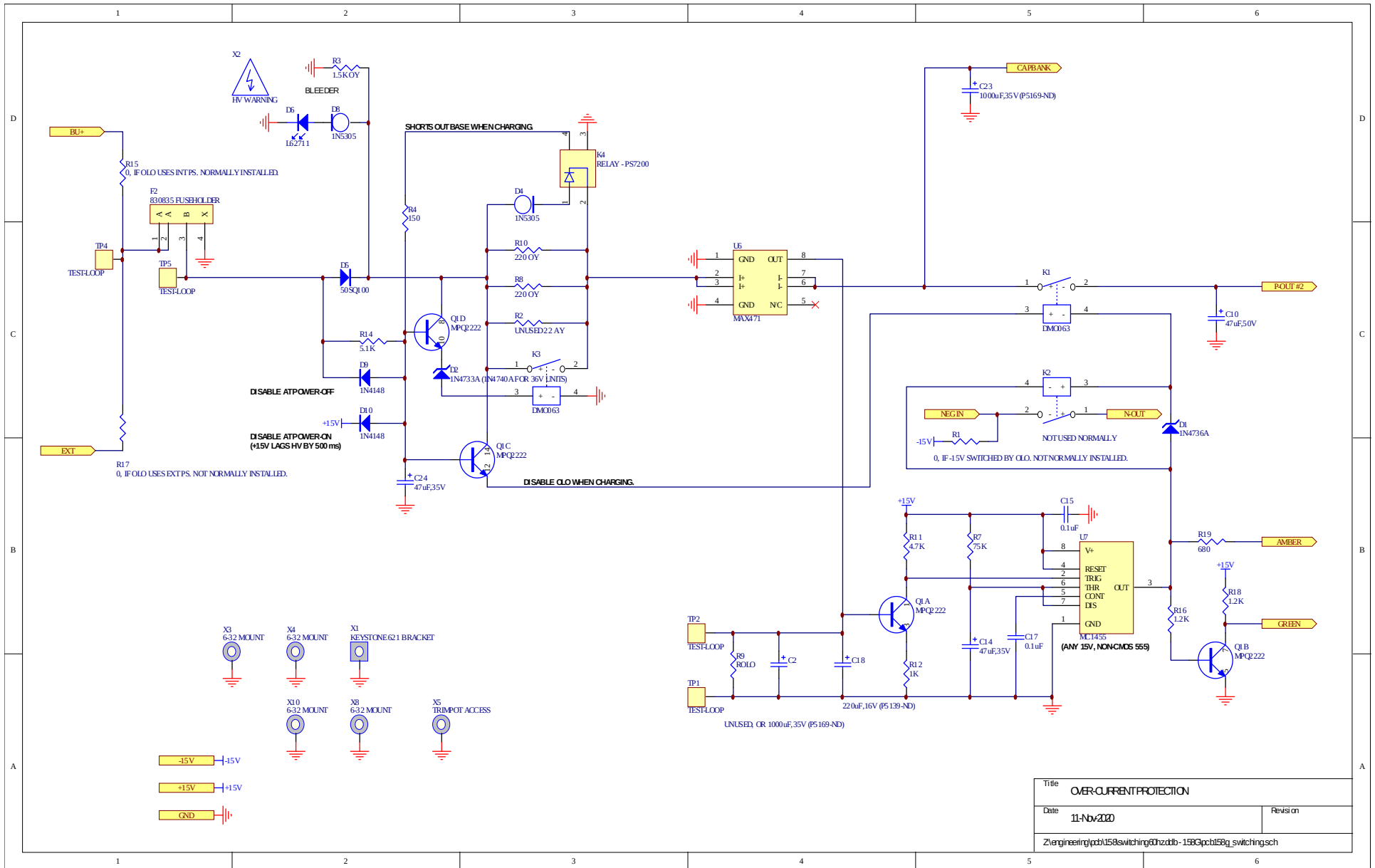

PCB 152B - OSCILLATOR AND TRIGGER CIRCUIT, 1/2

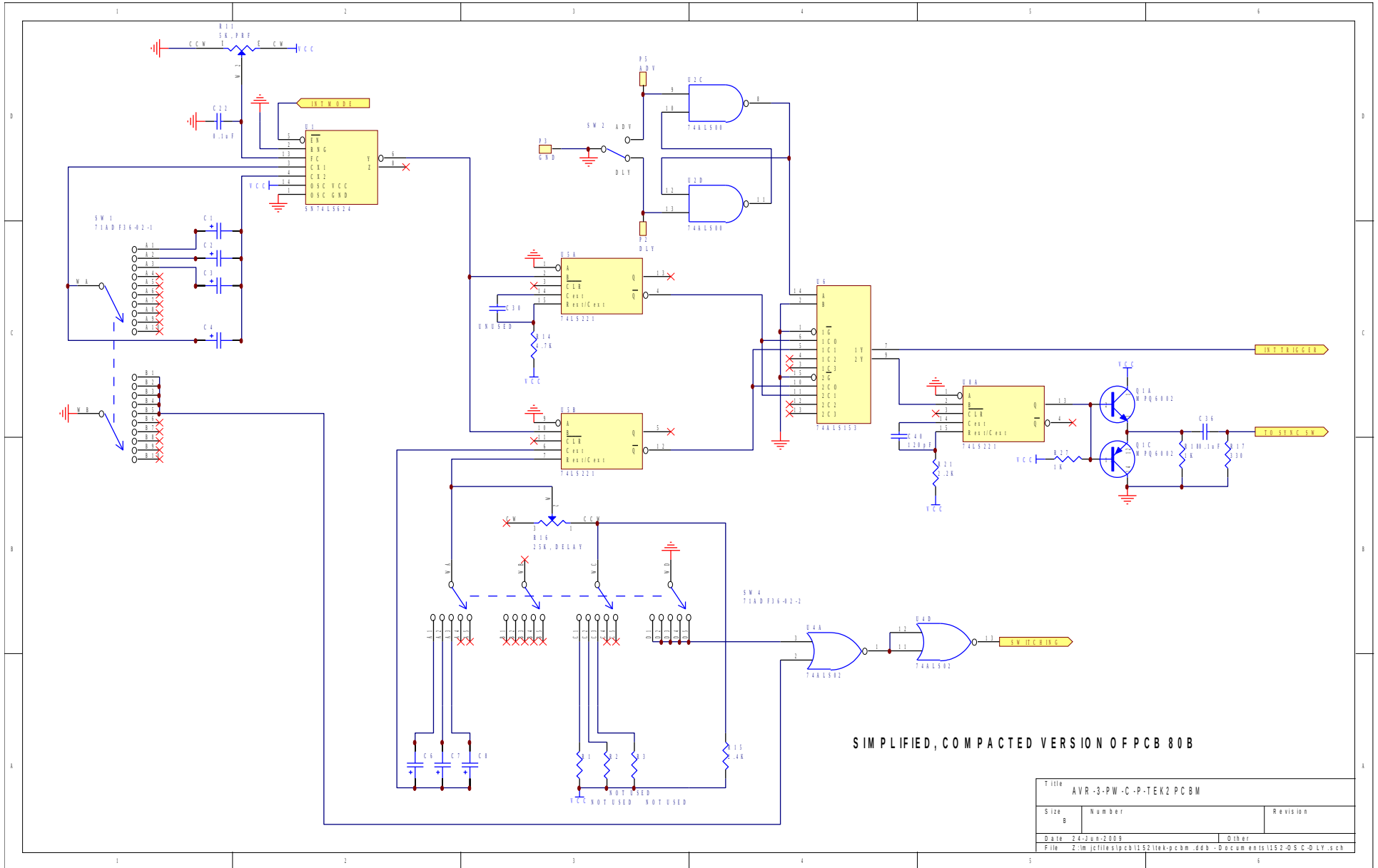

PCB 152B - OSCILLATOR AND TRIGGER CIRCUIT, 2/2

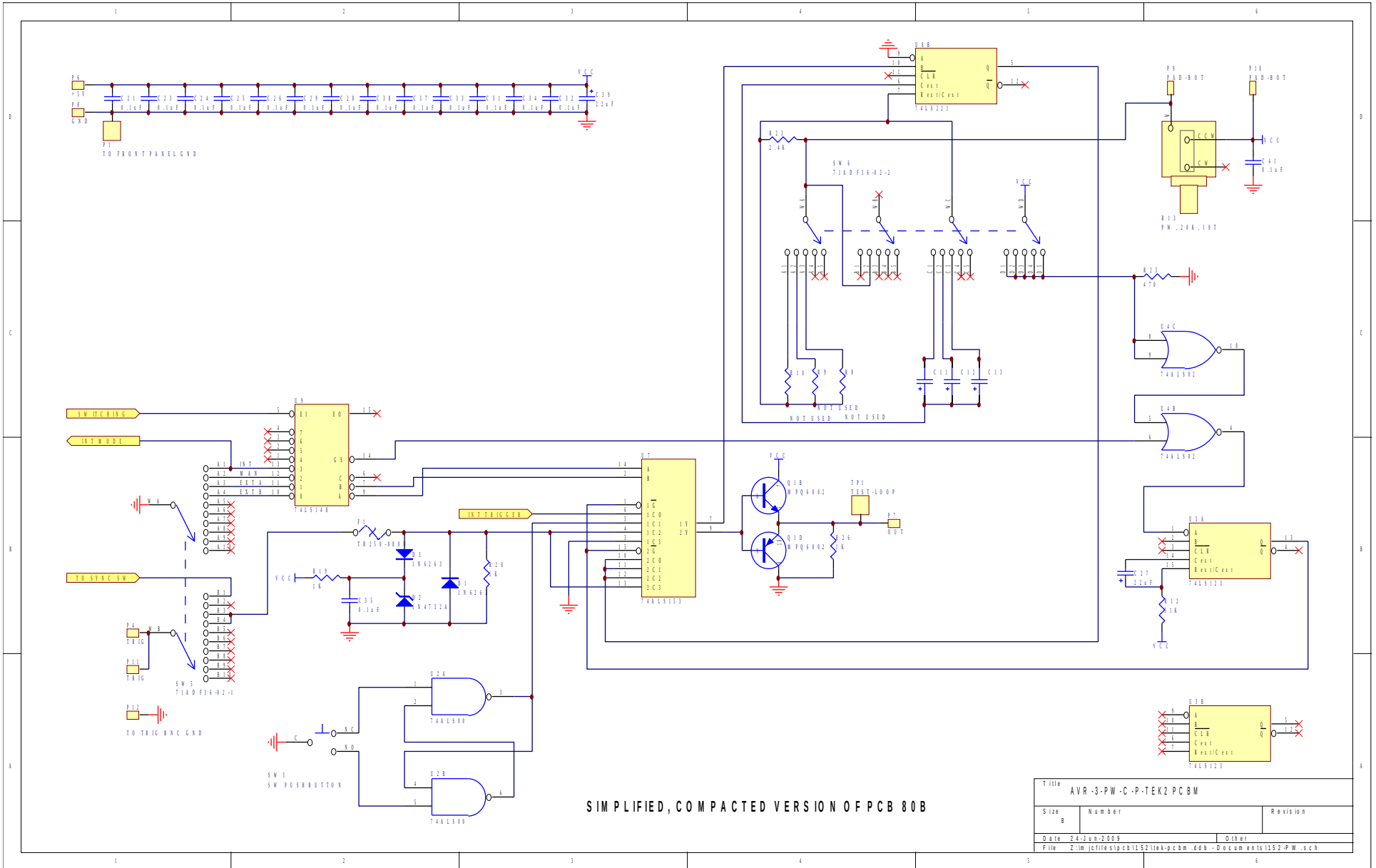

SIMPLIFIED, COMPACTED VERSION OF PCB 80B

PCB 216E - OP AMP BUFFERS

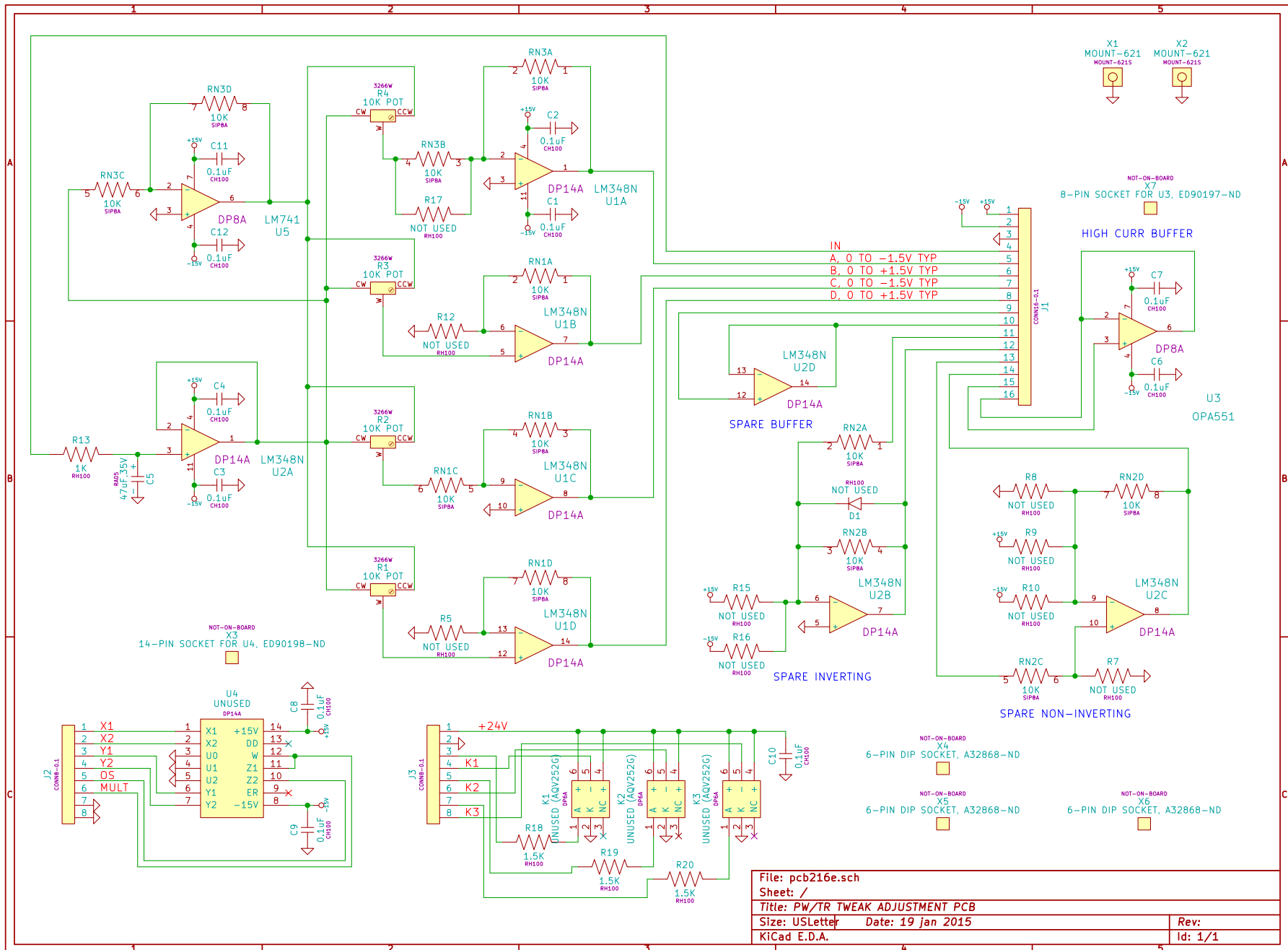

File: pcb216e.sch	Rev:
Sheet: /	Id: 1/1
Title: PW/TR TWEAK ADJUSTMENT PCB	
Size: USLetter Date: 19 jan 2015	

MAIN WIRING

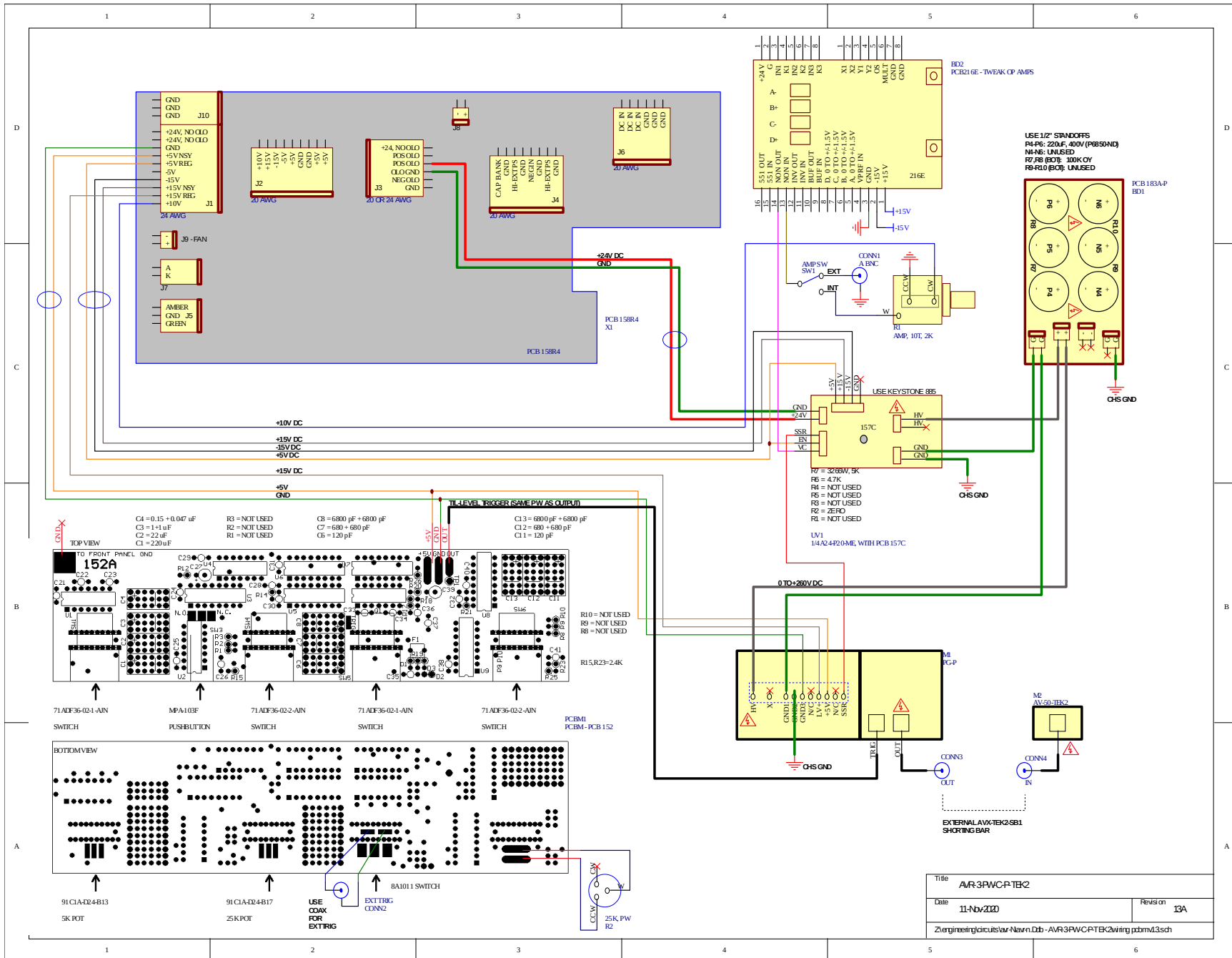

PERFORMANCE CHECK SHEET