



AVTECH ELECTROSYSTEMS LTD.

NANOSECOND WAVEFORM ELECTRONICS  
SINCE 1975

P.O. BOX 265  
OGDENSBURG, NY  
U.S.A. 13669-0265  
TEL: (315) 472-5270  
FAX: (613) 226-2802

TEL: 1-800-265-6681  
FAX: 1-800-561-1970

e-mail: [info@avtechpulse.com](mailto:info@avtechpulse.com)  
<http://www.avtechpulse.com/>

BOX 5120, LCD MERIVALE  
OTTAWA, ONTARIO  
CANADA K2C 3H4  
TEL: (613) 226-5772  
FAX: (613) 226-2802

## INSTRUCTIONS

MODEL AVR-3-PW-TEK3-B

0-250V, 0-5A, 10 ns RISE TIME,

0-50V, 0-5A, 0.5 ns RISE TIME

PULSE GENERATOR

SERIAL NUMBER: \_\_\_\_\_

### WARRANTY

Avtech Electrosystems Ltd. warrants products of its manufacture to be free from defects in material and workmanship under conditions of normal use. If, within one year after delivery to the original owner, and after prepaid return by the original owner, this Avtech product is found to be defective, Avtech shall at its option repair or replace said defective item. This warranty does not apply to units which have been disassembled, modified or subjected to conditions exceeding the applicable specifications or ratings. This warranty is the extent of the obligation assumed by Avtech with respect to this product and no other warranty or guarantee is either expressed or implied.

### TECHNICAL SUPPORT

Phone: 613-226-5772 or 1-800-265-6681

Fax: 613-226-2802 or 1-800-561-1970

E-mail: [info@avtechpulse.com](mailto:info@avtechpulse.com)

World Wide Web: <http://www.avtechpulse.com>

## TABLE OF CONTENTS

<b>WARRANTY.....</b>	<b>2</b>
<b>TECHNICAL SUPPORT.....</b>	<b>2</b>
<b>TABLE OF CONTENTS.....</b>	<b>3</b>
<b>INTRODUCTION.....</b>	<b>5</b>
<b>SPECIFICATIONS.....</b>	<b>7</b>
<b>EUROPEAN REGULATORY NOTES.....</b>	<b>8</b>
EC DECLARATION OF CONFORMITY.....	8
DIRECTIVE 2002/95/EC (RoHS).....	8
<b>INSTALLATION.....</b>	<b>9</b>
VISUAL CHECK.....	9
POWER RATINGS.....	9
CONNECTION TO THE POWER SUPPLY.....	9
PROTECTION FROM ELECTRIC SHOCK.....	10
ENVIRONMENTAL CONDITIONS.....	10
<b>FUSES.....</b>	<b>12</b>
AC FUSE REPLACEMENT.....	12
DC FUSE REPLACEMENT.....	13
FUSE RATINGS.....	13
<b>FRONT PANEL CONTROLS.....</b>	<b>14</b>
<b>REAR PANEL CONTROLS.....</b>	<b>16</b>
<b>GENERAL INFORMATION.....</b>	<b>18</b>
BASIC TEST ARRANGEMENT, WITHOUT OUTPUT MODULES.....	18
BASIC TEST ARRANGEMENT, WITH OUTPUT MODULES.....	19
OUTPUT MODULE EQUIVALENT CIRCUIT.....	21
BASIC PULSE CONTROL.....	22
TRIGGER MODES.....	24
GATING MODES.....	24
REPLACEMENT CABLES.....	24
UNUSED OUTPUTS.....	25
<b>TYPICAL RESULTS.....</b>	<b>26</b>
OUT1.....	26
OUT2.....	27
<b>MEASUREMENT ACCURACY AND CALIBRATION.....</b>	<b>30</b>

VOLTAGE AMPLITUDE CALIBRATION.....	30
LOAD RESISTANCE CALIBRATION.....	30
<b>OPERATIONAL CHECK.....</b>	<b>31</b>
<b>PROGRAMMING YOUR PULSE GENERATOR.....</b>	<b>34</b>
KEY PROGRAMMING COMMANDS.....	34
ALL PROGRAMMING COMMANDS.....	35
<b>MECHANICAL INFORMATION.....</b>	<b>37</b>
TOP COVER REMOVAL.....	37
RACK MOUNTING.....	37
ELECTROMAGNETIC INTERFERENCE.....	37
<b>MAINTENANCE.....</b>	<b>38</b>
REGULAR MAINTENANCE.....	38
CLEANING.....	38
<b>WIRING DIAGRAMS.....</b>	<b>0</b>
WIRING OF AC POWER.....	0
PCB 158H - LOW VOLTAGE POWER SUPPLY, 1/3.....	1
PCB 158H - LOW VOLTAGE POWER SUPPLY, 2/3.....	2
PCB 158H - LOW VOLTAGE POWER SUPPLY, 3/3.....	3
PCB 168B - HIGH VOLTAGE DC POWER SUPPLY.....	4
PCB 157B - HIGH VOLTAGE DISCHARGE BOARD.....	5
PCB 183A - CAPACITOR BANKS.....	6
PCB 174 - DUAL CHANNEL PULSE WIDTH BOARD.....	7
PCB 104D - KEYPAD / DISPLAY BOARD, 1/3.....	8
PCB 104D - KEYPAD / DISPLAY BOARD, 2/3.....	9
PCB 104D - KEYPAD / DISPLAY BOARD, 3/3.....	10
MAIN WIRING (-P UNITS).....	11
<b>PERFORMANCE CHECK SHEET.....</b>	<b>0</b>

## INTRODUCTION

The AVR-3-PW-TEK3-B series is specifically designed for testing Tektronix current probes. Two main output channels are provided.

One output provides 10 ns rise time voltage pulses (0 to 250V, 250 ns to 250 us), suitable for testing A6303 or TCP303 probes. A 50 $\Omega$  termination is provided inside a supplied output module. A variable current of up to 5 Amperes is defined by the 250 Volt pulse and the 50 $\Omega$  termination. For other applications, the output pulse may be connected to a user-supplied 50 $\Omega$  load, if desired.

The second output is intended for testing lower-current, higher-speed current probes. It can generate pulse amplitudes up to 50V and 1A, with 0.5 ns rise times. The pulse width is variable from 50 ns to 200 ns.

The two outputs allow this model to test both high-speed lower-current probes such as the TCP312 or TCP305, and lower-speed high-current probes such as the A6303 or TCP303.

An external output module is provided for each output. Replaceable flexible shorting cables are mounted on these output modules. (The shorting cables are standard RG-316 coaxial cables.) During tests, the output module are connected to the mainframe by a 12" / 30 cm length of coaxial cable, and the current probes are clamped around the shorting cables. The output modules also contain the 50 Ohm termination.

The supplied cables and output modules are designed to preserve the fast rise and falls times as much as possible, despite the parasitic inductance introduced by the probes and the unshielded connections (i.e., imperfect transmission lines) required to measure current flow.

The AVR-3-PW-TEK3-B is optionally available with an additional output module that is physically suitable for use with the Tektronix CT-1 and CT-2 ultra-fast (i.e., sub-nanosecond rise time) current probes.

Instruments with the "-P" model suffix can generate positive output voltages (and thus source current), whereas instruments with the "-N" model suffix can generate negative voltages (and thus sink current).

The AVR-3-PW-TEK3-B is a highly flexible instrument. Aside from the internal trigger source, it can also be triggered or gated by external TTL-level signals. A front-panel pushbutton or a computer command can also be used to trigger the instrument.

The AVR-3-PW-TEK3-B features front panel keyboard and adjust knob control of the output pulse parameters along with a four line by 40 character back-lit LCD display of the output amplitude, pulse width, pulse repetition frequency, and delay. The instrument includes memory to store up to four complete instrument setups. The operator may use

the front panel or the computer interface to store a complete “snapshot” of all key instrument settings, and recall this setup at a later time.

This instrument is intended for use in research, development, test and calibration laboratories by qualified personnel.

## SPECIFICATIONS

Model:	AVR-3-PW-TEK3-B <sup>1</sup>	
Basic Description:	High and low current "combo" pulser, with GPIB / RS-232	
Number of Outputs:	2	
	Output 1	Output 2
Amplitude ( $R_L \geq 50 \Omega$ ) <sup>2</sup> :	0 to 250 V	0 to 50 V
Amplitude accuracy:	Greater of $\pm 2\%$ or $\pm 0.5V$ .	
Provided termination:	50.0 $\pm$ 1%	
Voltage rise & fall times: (20%-80%)	$\leq 10$ ns	$\leq 0.5$ ns
Pulse width (FWHM):	250 ns to 250 $\mu$ s	50 to 200 ns
Drop (at max. pulse width):	$\leq 2\%$	
Overshoot (at max. amp.):	$\leq 5\%$	
PRF:	Internal trigger: 1 Hz to 10 kHz External trigger: 0 Hz to 10 kHz	
Duty cycle (max):	0.25%	0.2%
Polarity <sup>3</sup> :	Positive or negative (specify)	
Propagation delay:	$\leq 150$ ns (Ext trig in to pulse out)	
Jitter:	$\pm 100$ ps $\pm$ 0.03% of sync delay (Ext trig in to pulse out)	
Mainframe output connector:	BNC	SMA
Probe attachment style:	Flexible clamping cable on output module <sup>4</sup> . The output module is connected to the front panel by a 12" / 30 cm coaxial cable.	
Trigger required for ext trig modes:	TTL, 50 ns or wider	
Sync delay:	Variable to $\pm 250$ $\mu$ s (sync out to pulse out). Common to all outputs.	
Sync output:	+3 Volts, 100 ns (will drive 50 $\Omega$ loads)	
Gated operation:	Synchronous or asynchronous, active high or low, switchable.	
GPIB and RS-232 control <sup>1</sup> :	Standard feature on all -B units.	
LabView drivers:	Check for available downloads at <a href="http://www.avtechpulse.com/labview">http://www.avtechpulse.com/labview</a> .	
Telnet / Ethernet control <sup>5</sup> :	Optional. See <a href="http://www.avtechpulse.com/options/tnt">http://www.avtechpulse.com/options/tnt</a> for details	
Power requirements:	100 - 240 Volts, 50 - 60 Hz	
Dimensions:	100 mm x 430 mm x 375 mm (3.9" x 17" x 14.8")	
Chassis material:	Cast aluminum frame and handles, blue vinyl on aluminum cover plates	
Mounting:	Any. Add -R5 to the model number to add a rack-mount kit.	
Temperature range:	+5°C to +40°C	

- 1) -B suffix indicates IEEE-488.2 GPIB and RS-232 control of amplitude, pulse width, PRF and delay (See <http://www.avtechpulse.com/gpib>).
- 2) For operation at amplitudes of less than 10% of full-scale, best results will be obtained by setting the amplitude near full-scale and using external attenuators on the output.
- 3) Indicate desired polarity by suffixing model number with -P or -N (i.e. positive or negative).
- 4) An optional additional output module is available for "Output 2" of the AVR-3-PW-TEK3-B, which is suitable for use with CT-1 and CT-2 current probes. This output module uses a very short length of de-solderable bus-bar wire (instead of flexible cable) which must be fed through the probe. Add the suffix "-CT" to the model number to specify this option.
- 5) Add the suffix -TNT to the model number to specify the Telnet / Ethernet control option.

## EUROPEAN REGULATORY NOTES

### EC DECLARATION OF CONFORMITY

We

Avtech Electrosystems Ltd.  
P.O. Box 5120, LCD Merivale  
Ottawa, Ontario  
Canada K2C 3H4

declare that this pulse generator meets the intent of Directive 89/336/EEC for Electromagnetic Compatibility. Compliance pertains to the following specifications as listed in the official Journal of the European Communities:

EN 50081-1 Emission

EN 50082-1 Immunity

and that this pulse generator meets the intent of the Low Voltage Directive 72/23/EEC as amended by 93/68/EEC. Compliance pertains to the following specifications as listed in the official Journal of the European Communities:

EN 61010-1:2001 Safety requirements for electrical equipment for measurement, control, and laboratory use



### DIRECTIVE 2002/95/EC (RoHS)

This instrument is exempt from Directive 2002/95/EC of the European Parliament and of the Council of 27 January 2003 on the Restriction of the use of certain Hazardous Substances (RoHS) in electrical and electronic equipment. Specifically, Avtech instruments are considered "Monitoring and control instruments" (Category 9) as defined in Annex 1A of Directive 2002/96/EC. The Directive 2002/95/EC only applies to Directive 2002/96/EC categories 1-7 and 10, as stated in the "Article 2 - Scope" section of Directive 2002/95/EC.



## INSTALLATION

### VISUAL CHECK

After unpacking the instrument, examine to ensure that it has not been damaged in shipment. Visually inspect all connectors, knobs, liquid crystal displays (LCDs), and the handles. Confirm that the following items have been supplied with the instrument:

- A power cord
- A GPIB cable
- Two instrumentation manuals (this manual and the “Programming Manual for -B Instruments”)
- Two output modules (AVX-TEK3-TM1 and AVX-TEK3-TM2), with a 6" / 15 cm length of RG-316 installed across the "A" and "B" connectors of each module.
- A 12" / 30 cm length of RG-58 coaxial cable.
- A 12" / 30 cm length of RG-316 coaxial cable.

If the instrument has been damaged, file a claim immediately with the company that transported the instrument.

### POWER RATINGS

This instrument is intended to operate from 100 - 240 V, 50 - 60 Hz.

The maximum power consumption is 90 Watts. Please see the “FUSES” section for information about the appropriate AC and DC fuses.

This instrument is an “Installation Category II” instrument, intended for operation from a normal single-phase supply.

### CONNECTION TO THE POWER SUPPLY

An IEC-320 three-pronged recessed male socket is provided on the back panel for AC power connection to the instrument. One end of the detachable power cord that is supplied with the instrument plugs into this socket. The other end of the detachable power cord plugs into the local mains supply. Use only the cable supplied with the instrument. The mains supply must be earthed, and the cord used to connect the instrument to the mains supply must provide an earth connection. (The supplied cord does this.)

 Warning: Failure to use a grounded outlet may result in injury or death due to electric shock. This product uses a power cord with a ground connection. It must be connected to a properly grounded outlet. The instrument chassis is connected to the ground wire in the power cord.

The table below describes the power cord that is normally supplied with this instrument, depending on the destination region:

Destination Region	Description	Manufacturer	Part Number
Continental Europe	European CEE 7/7 "Schuko" 230V, 50Hz	Volex ( <a href="http://www.volex.com">http://www.volex.com</a> )	17850-C3-326
		Qualtek ( <a href="http://www.qualtekusa.com">http://www.qualtekusa.com</a> )	319004-T01
United Kingdom	BS 1363, 230V, 50Hz	Qualtek ( <a href="http://www.qualtekusa.com">http://www.qualtekusa.com</a> )	370001-E01
Switzerland	SEV 1011, 2 30V, 50Hz	Volex ( <a href="http://www.volex.com">http://www.volex.com</a> )	2102H-C3-10
Israel	SI 32, 220V, 50Hz	Volex ( <a href="http://www.volex.com">http://www.volex.com</a> )	2115H-C3-10
North America, and all other areas	NEMA 5-15, 120V, 60 Hz	Qualtek ( <a href="http://www.qualtekusa.com">http://www.qualtekusa.com</a> )	312007-01

### PROTECTION FROM ELECTRIC SHOCK

 Operators of this instrument must be protected from electric shock at all times. The owner must ensure that operators are prevented access and/or are insulated from every connection point. In some cases, connections must be exposed to potential human contact. Operators must be trained to protect themselves from the risk of electric shock. This instrument is intended for use by qualified personnel who recognize shock hazards and are familiar with safety precautions required to avoid possibly injury. In particular, operators should:

- 1) Keep exposed high-voltage wiring to an absolute minimum.
- 2) Wherever possible, use shielded connectors and cabling.
- 3) Connect and disconnect loads and cables only when the instrument is turned off.
- 4) Keep in mind that all cables, connectors, oscilloscope probes, and loads must have an appropriate voltage rating.
- 5) Do not attempt any repairs on the instrument, beyond the fuse replacement procedures described in this manual. Contact Avtech technical support (see page 2 for contact information) if the instrument requires servicing. Service is to be performed solely by qualified service personnel.

### ENVIRONMENTAL CONDITIONS

This instrument is intended for use under the following conditions:

1. indoor use;
2. altitude up to 2 000 m;
3. temperature 5 °C to 40 °C;
4. maximum relative humidity 80 % for temperatures up to 31 °C decreasing linearly to 50 % relative humidity at 40 °C;
5. Mains supply voltage fluctuations up to  $\pm 10$  % of the nominal voltage;
6. no pollution or only dry, non-conductive pollution.

## FUSES

This instrument contains four fuses. All are accessible from the rear-panel. Two protect the AC prime power input, and two protect the internal DC power supplies. The locations of the fuses on the rear panel are shown in the figure below:

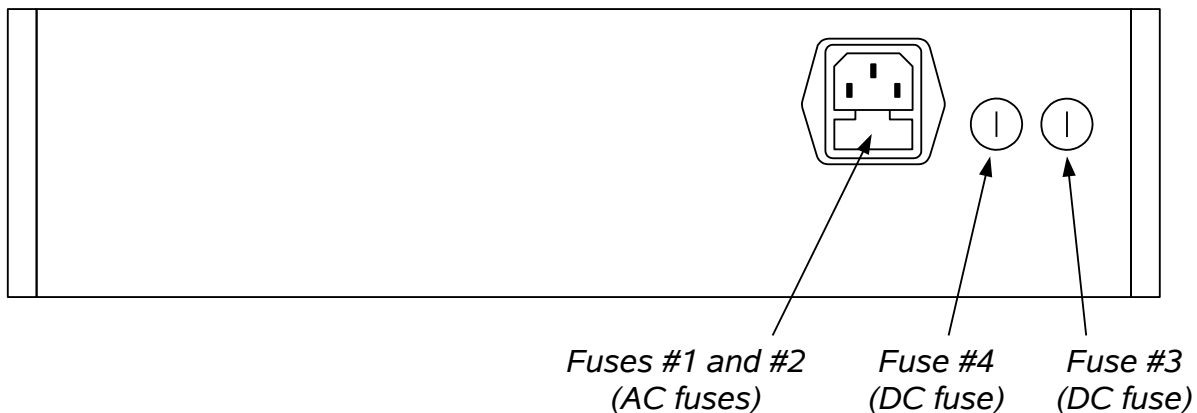

### AC FUSE REPLACEMENT

To physically access the AC fuses, the power cord must be detached from the rear panel of the instrument. The fuse drawer may then be extracted using a small flat-head screwdriver, as shown below:

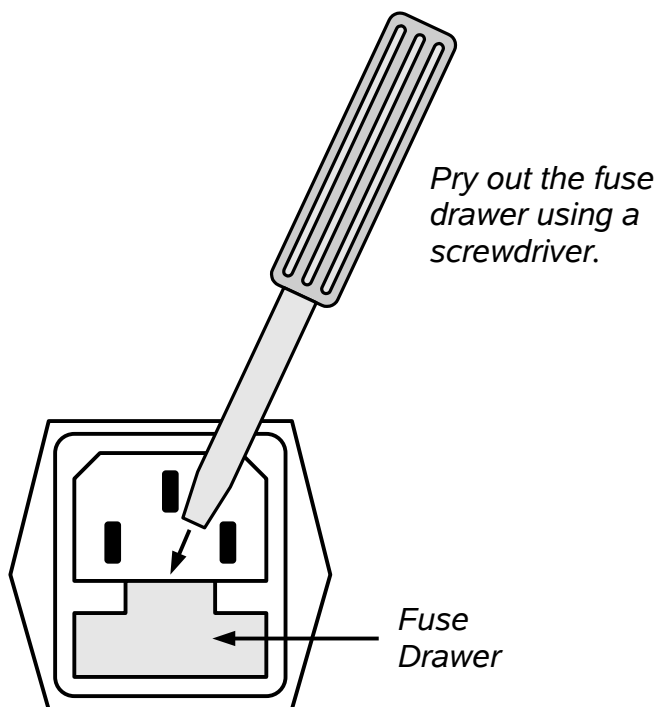

## DC FUSE REPLACEMENT

The DC fuses may be replaced by inserting the tip of a flat-head screwdriver into the fuse holder slot, and rotating the slot counter-clockwise. The fuse and its carrier will then pop out.

## FUSE RATINGS

The following table lists the required fuses:

Fuses	Nominal Mains Voltage	Rating	Case Size	Manufacturer's Part Number (Wickmann)	Distributor's Part Number (Digi-Key)
#1, #2 (AC)	115 V	0.8A, 250V, Time-Delay	5×20 mm	1950800000	WK5046-ND
	230 V	0.5A, 250V, Time-Delay	5×20 mm	1950500000	WK5041-ND
#3 (DC)	N/A	2.5A, 250V, Time-Delay	5×20 mm	1951250000	WK5058-ND
#4 (DC)	N/A	1.6A, 250V, Time-Delay	5×20 mm	1951160000	WK5053-ND

The fuse manufacturer is Wickmann (<http://www.wickmann.com/>).

Replacement fuses may be easily obtained from Digi-Key (<http://www.digikey.com/>) and other distributors.

## FRONT PANEL CONTROLS

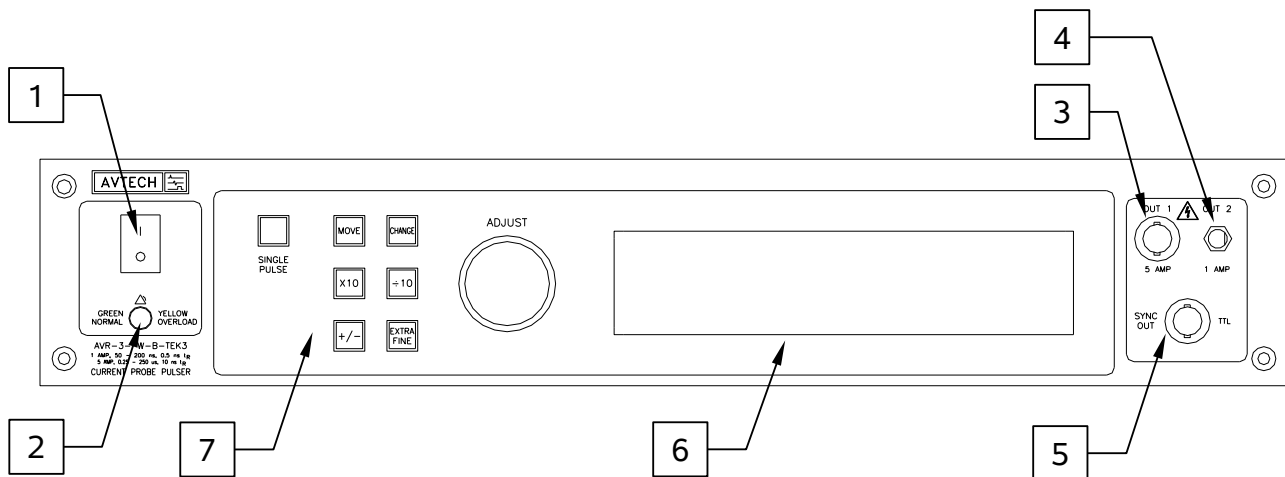

1. **POWER Switch.** This is the main power switch. When turning the instrument on, there may be a delay of several seconds before the instrument appears to respond.
2. **OVERLOAD Indicator.** When the instrument is powered, this indicator is normally green, indicating normal operation. If this indicator is yellow, an internal automatic overload protection circuit has been tripped. If the unit is overloaded (by operating at an exceedingly high duty cycle or by operating into a very low impedance), the protective circuit will disable the output of the instrument and turn the indicator light yellow. The light will stay yellow (i.e. output disabled) for about 5 seconds after which the instrument will attempt to re-enable the output (i.e. light green) for about 1 second. If the overload condition persists, the output will be disabled again (i.e. light yellow) for another 5 seconds. If the overload condition has been removed, the instrument will resume normal operation.

This overload indicator may flash yellow briefly at start-up. This is not a cause for concern.

3. **OUT1 CONNECTOR.** This BNC connector provides the 250V/5A (maximum) output with 10 ns rise times. It is normally connected to the AVX-TEK3-TM1 output module using a 12" / 30 cm length of RG-58 coaxial cable.
4. **OUT2 CONNECTOR.** This SMA connector provides the 50V/1A (maximum) output with 0.5 ns rise times. It is normally connected to the AVX-TEK3-TM2 output module using a 12" / 30 cm length of RG-316 coaxial cable.
5. **SYNC OUT.** This connector supplies a SYNC output that can be used to trigger other equipment, particularly oscilloscopes. This signal leads (or lags) the main outputs by a duration set by the "DELAY" controls and has an approximate amplitude of +3 Volts to  $R_L > 50\Omega$  with a pulse width of approximately 100 ns.

6. LIQUID CRYSTAL DISPLAY (LCD). This LCD is used in conjunction with the keypad to change the instrument settings. Normally, the main menu is displayed, which lists the key adjustable parameters and their current values. The "Programming Manual for -B Instruments" describes the menus and submenus in detail.
7. KEYPAD.

Control Name	Function
MOVE	This moves the arrow pointer on the display.
CHANGE	This is used to enter the submenu, or to select the operating mode, pointed to by the arrow pointer.
×10	If one of the adjustable numeric parameters is displayed, this increases the setting by a factor of ten.
÷10	If one of the adjustable numeric parameters is displayed, this decreases the setting by a factor of ten.
+/-	If one of the adjustable numeric parameters is displayed, and this parameter can be both positive or negative, this changes the sign of the parameter.
EXTRA FINE	This changes the step size of the ADJUST knob. In the extra-fine mode, the step size is twenty times finer than in the normal mode. This button switches between the two step sizes.
ADJUST	This large knob adjusts the value of any displayed numeric adjustable values, such as frequency, pulse width, etc. The adjust step size is set by the "EXTRA FINE" button.  When the main menu is displayed, this knob can be used to move the arrow pointer.

## REAR PANEL CONTROLS

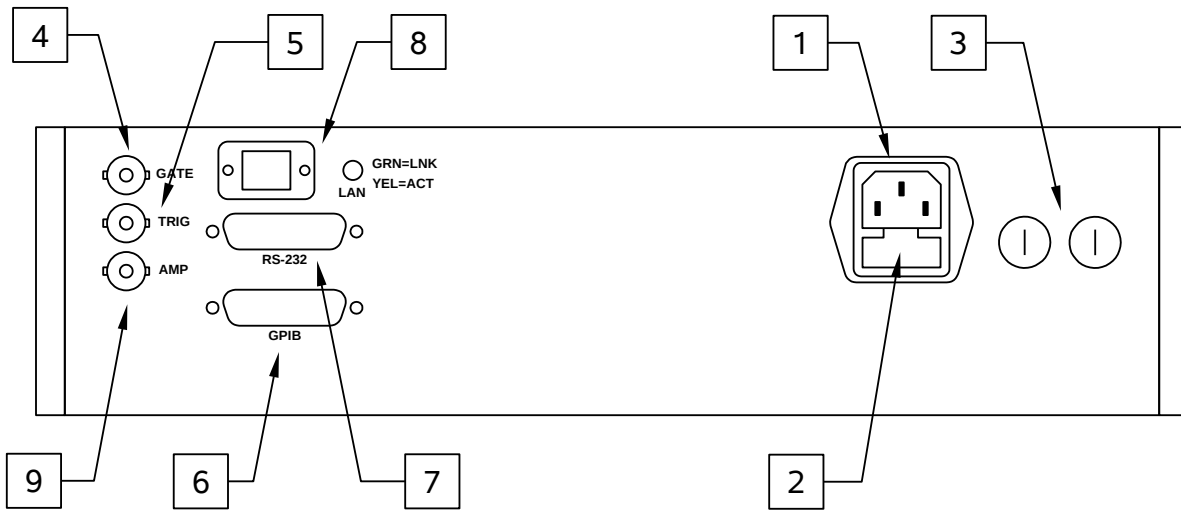

1. AC POWER INPUT. An IEC-320 C14 three-pronged recessed male socket is provided on the back panel for AC power connection to the instrument. One end of the detachable power cord that is supplied with the instrument plugs into this socket.
2. AC FUSE DRAWER. The two fuses that protect the AC input are located in this drawer. Please see the “FUSES” section of this manual for more information.
3. DC FUSES. These two fuses protect the internal DC power supplies. Please see the “FUSES” sections of this manual for more information.
4. GATE. This TTL-level (0 and +5V) logic input can be used to gate the triggering of the instrument. This input can be either active high or active low, depending on the front panel settings or programming commands. (The instrument triggers normally when this input is unconnected). When set to active high mode, this input is pulled-down to ground by a 1 k $\Omega$  resistor. When set to active low mode, this input is pulled-up to +5V by a 1 k $\Omega$  resistor.
5. TRIG. This TTL-level (0 and +5V) logic input can be used to trigger the instrument, if the instrument is set to triggering externally. The instrument triggers on the rising edge of this input. The input impedance of this input is 1 k $\Omega$ . (Depending on the length of cable attached to this input, and the source driving it, it may be desirable to add a coaxial 50 Ohm terminator to this input to provide a proper transmission line termination. The Pasternack ([www.pasternack.com](http://www.pasternack.com)) PE6008-50 BNC feed-thru 50 Ohm terminator is suggested for this purpose.)

When triggering externally, the instrument can be set such that the output pulse width tracks the pulse width on this input, or the output pulse width can be set independently.



6. GPIB Connector. A standard GPIB cable can be attached to this connector to allow the instrument to be computer-controlled. See the “Programming Manual for -B Instruments” for more details on GPIB control.
7. RS-232 Connector. A standard serial cable with a 25-pin male connector can be attached to this connector to allow the instrument to be computer-controlled. See the “Programming Manual for -B Instruments” for more details on RS-232 control.
8. LAN Connector and Indicator. (Optional feature. Present on -TNT units only.) The -TNT option "Internet-enables" Avtech pulse generators by adding this standard Ethernet port to the rear panel, in addition to the IEEE-488.2 GPIB and RS-232 ports normally found on "-B" units. Commands may be sent using the standard Telnet protocol, or using a web browser. The SCPI-compliant command set is the same as that used for GPIB and RS-232 control. The -TNT option uses the Dynamic Host Configuration Protocol (DHCP) to obtain its network address. A DHCP server must be present on the local network for the -TNT option to operate properly.
9. AMP Connector. This connector is not used.

## GENERAL INFORMATION

### BASIC TEST ARRANGEMENT, WITHOUT OUTPUT MODULES

For initial testing of the AVR-3-PW-TEK3-B, the instrument can be operated without the output modules. Both outputs require a 50 Ohm load. OUT1 can be observed on a common "real-time" oscilloscope with a bandwidth of 200 MHz or higher, since the rise time is approximately 10 ns. However, OUT2 should be observed with a high-bandwidth (> 2 GHz) sampling oscilloscope in order to accurately reproduce the very fast (< 500 ps) rise time.

For testing OUT1 with a real-time oscilloscope, the instrument should be connected as shown below:

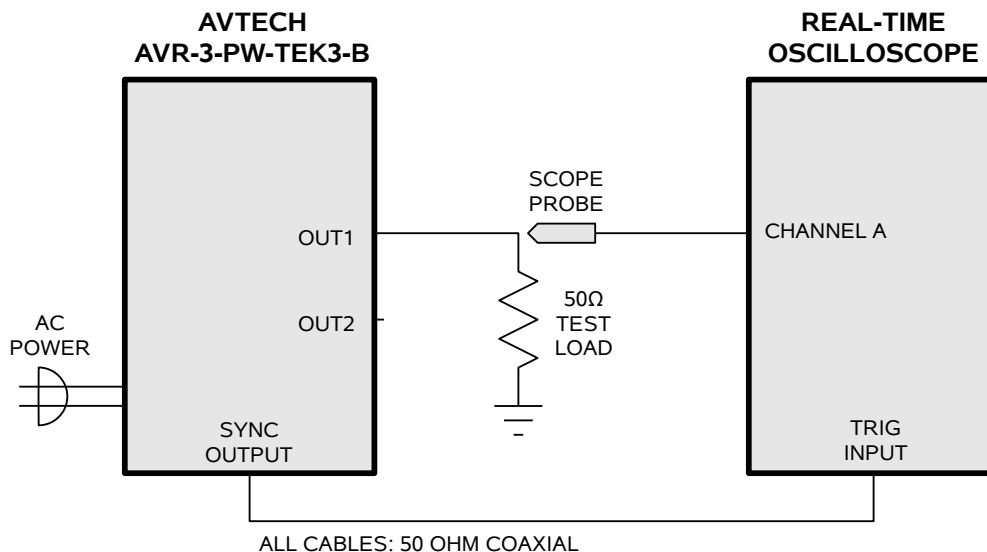

A high-quality low-inductance 50 Ohm load is required for the above test arrangement. The worst case power dissipation in the load resistor is 3.1 Watts.

For testing OUT2 with a high-bandwidth sampling oscilloscope, the instrument should be connected as shown below:

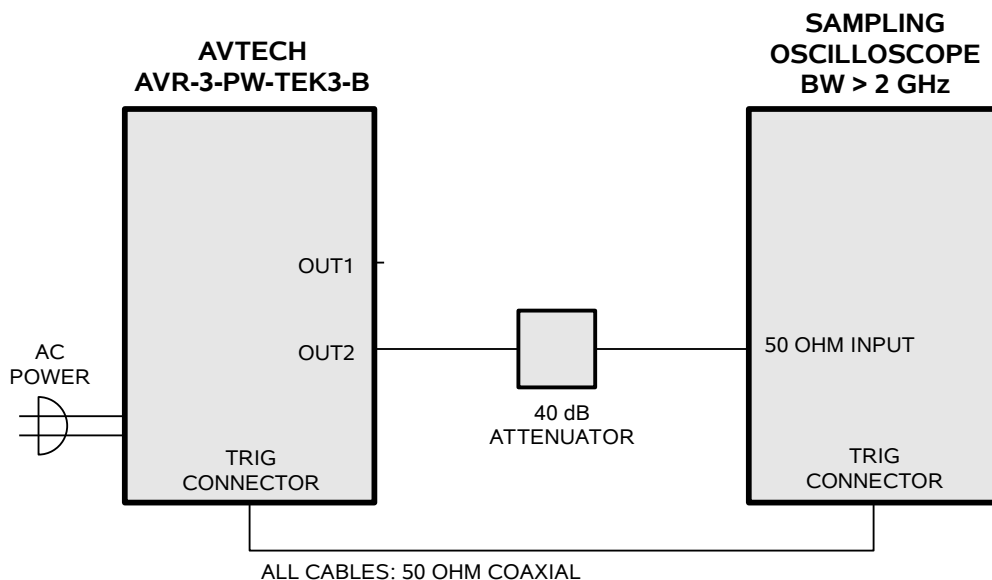

In the above test setup, all cables, attenuators, and oscilloscope should have bandwidth ratings of at least 2 GHz (and preferably > 10 GHz). The use of 40 dB attenuator at the sampling scope vertical input channel will insure a peak input signal to the sampling scope of less than 1 Volt, to avoid damaging the scope.

### BASIC TEST ARRANGEMENT, WITH OUTPUT MODULES

For normal operation, one or both of the output modules will be installed on the outputs.

When using OUT1, the basic test arrangement is shown below:

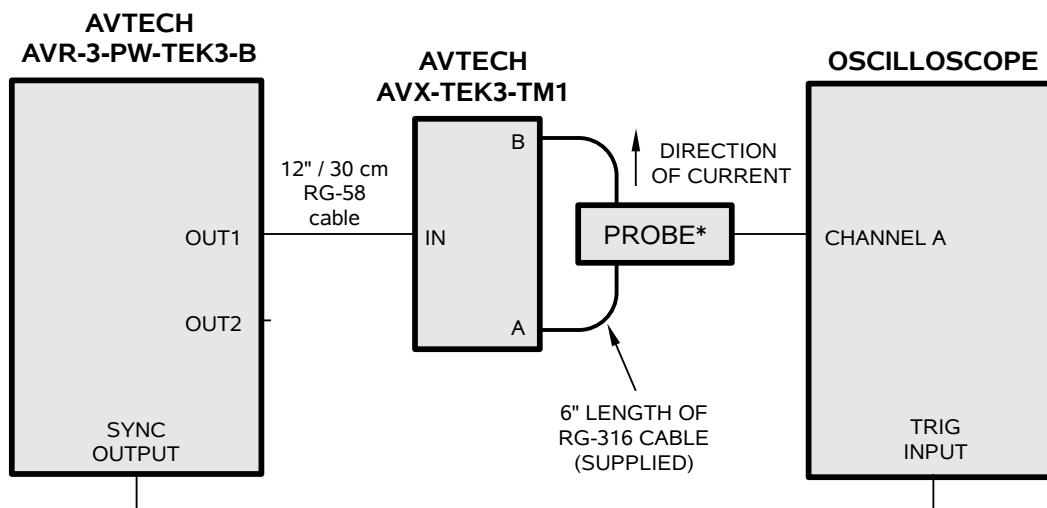

\* Depending on the exact current probe model, a probe amplifier may be needed between the probe and the oscilloscope.

The current probe under test is clamped to the 6" / 15 cm length of RG-316 cable across the "A" and "B" terminals of the output module. Physically, this arrangement is shown below (with a Tektronix A6303 probe):



When using OUT2, the basic test arrangement is shown below:

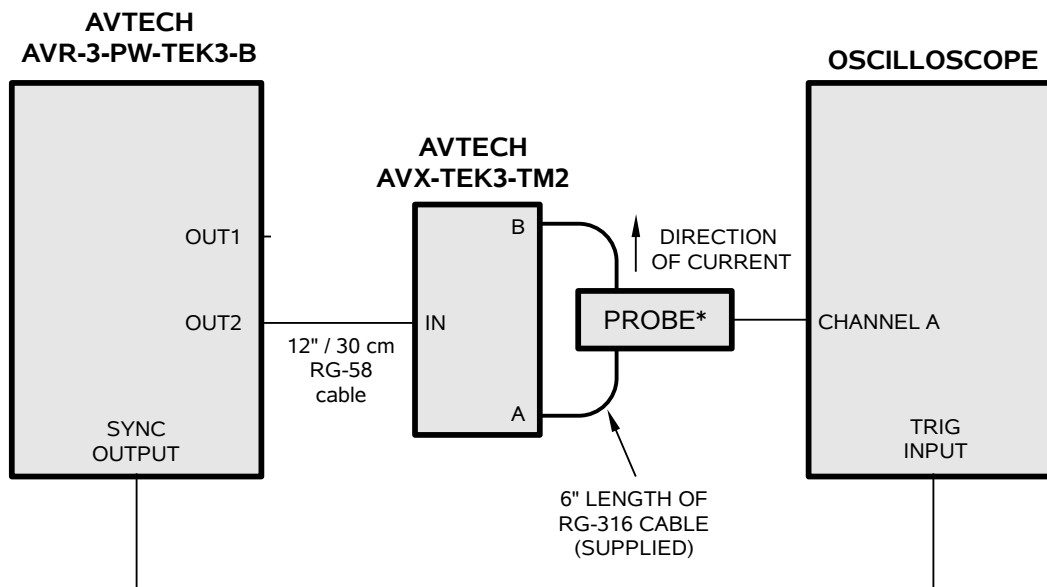

\* Depending on the exact current probe model, a probe amplifier may be needed between the probe and the oscilloscope.

This is very similar to the "OUT1" arrangement, except that a different output module is used, and a higher-bandwidth oscilloscope may be required. Physically, this arrangement is shown below (with a Tektronix P6042 probe):

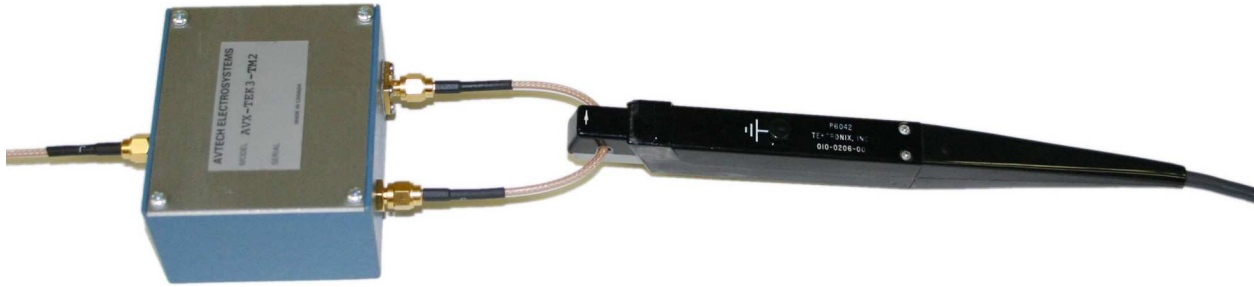

The OUT1 and OUT2 connectors are different. OUT1 has a BNC connector, and OUT2 has an SMA connector. The output modules have matching connectors, to make it obvious which output module is to be used with which output connector.

### OUTPUT MODULE EQUIVALENT CIRCUIT

The output modules serve two functions: they provide a physically convenient location to which to clamp the current probe under test to, and they contain the resistive load (or termination) which is required to define the current amplitude. The equivalent circuit (valid for both output modules) is shown below:

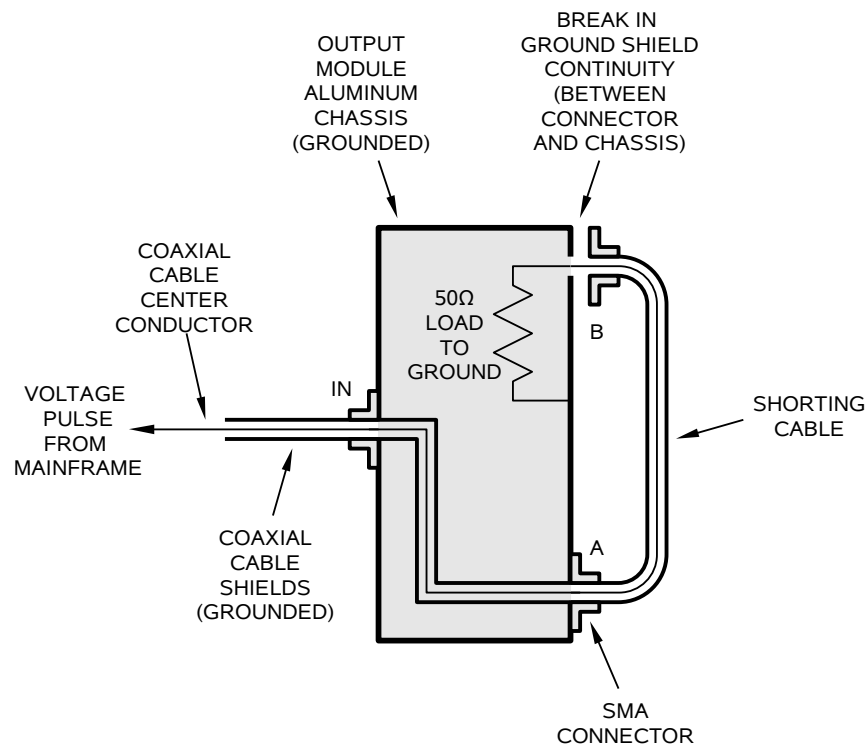

The connectivity of the ground shield of the shorting cable is deliberately broken so that current can not flow in the shield - if the cable shield was active, it would prevent the current probe from sensing the current on the center conductor!

## BASIC PULSE CONTROL

This instrument can be triggered by its own internal clock or by an external TTL trigger signal. In either case, three output channels respond to the trigger: OUT1, OUT2 and SYNC.

OUT1 and OUT2 have independently adjustable amplitude and pulse width settings. They share a common trigger source, however, and the OUT1 and OUT2 pulses are approximately simultaneous.

The SYNC pulse is a 100 ns wide TTL-level reference pulse used to trigger oscilloscopes or other measurement systems. When the delay is set to a positive value the SYNC pulse precedes the OUT1 and OUT2 pulses. When the delay is set to a negative value the SYNC pulse follows the OUT1 and OUT2 pulses.

These pulses are illustrated below, assuming internal triggering, positive amplitude, and a positive delay:

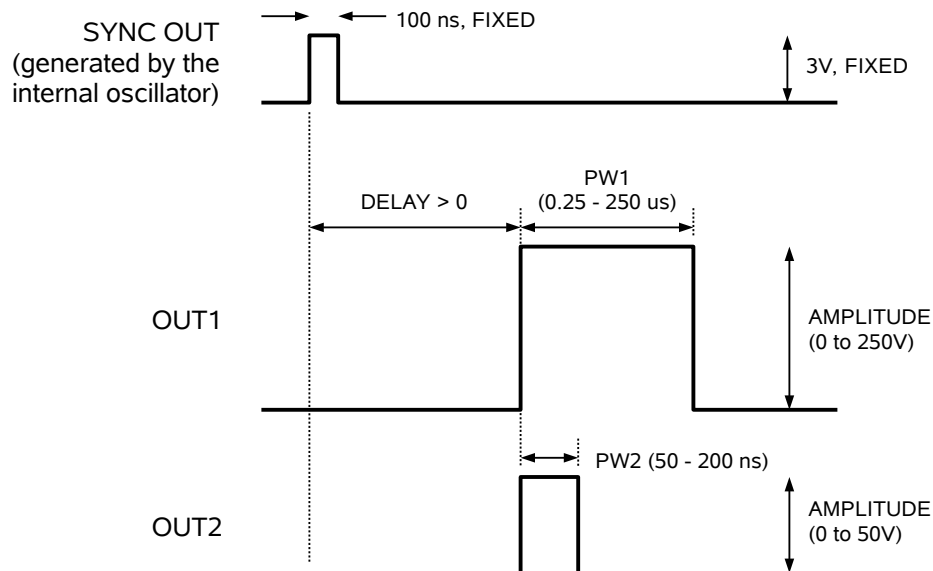

If the delay is negative, the order of the SYNC and OUT pulses is reversed:

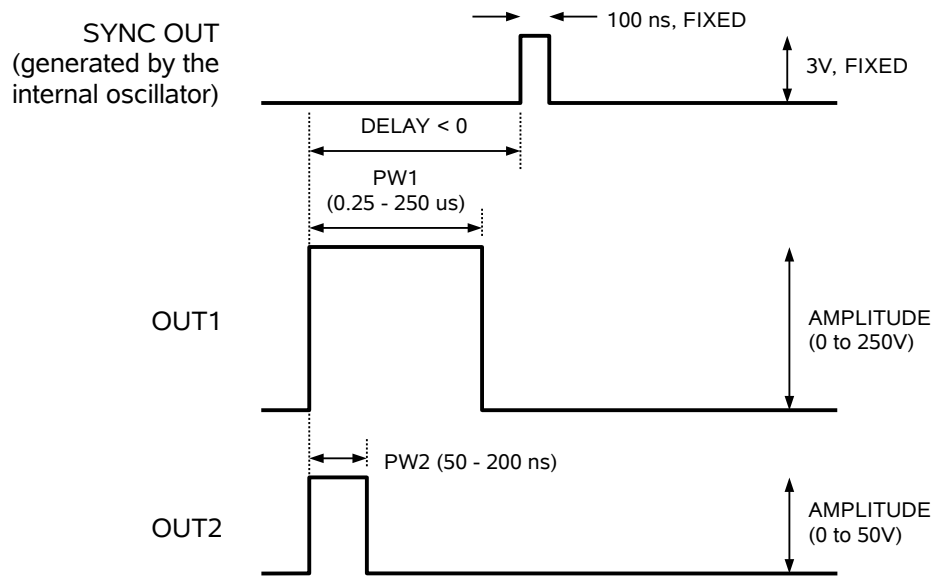

The next figure illustrates the relationship between the signals when an external TTL-level trigger is used:

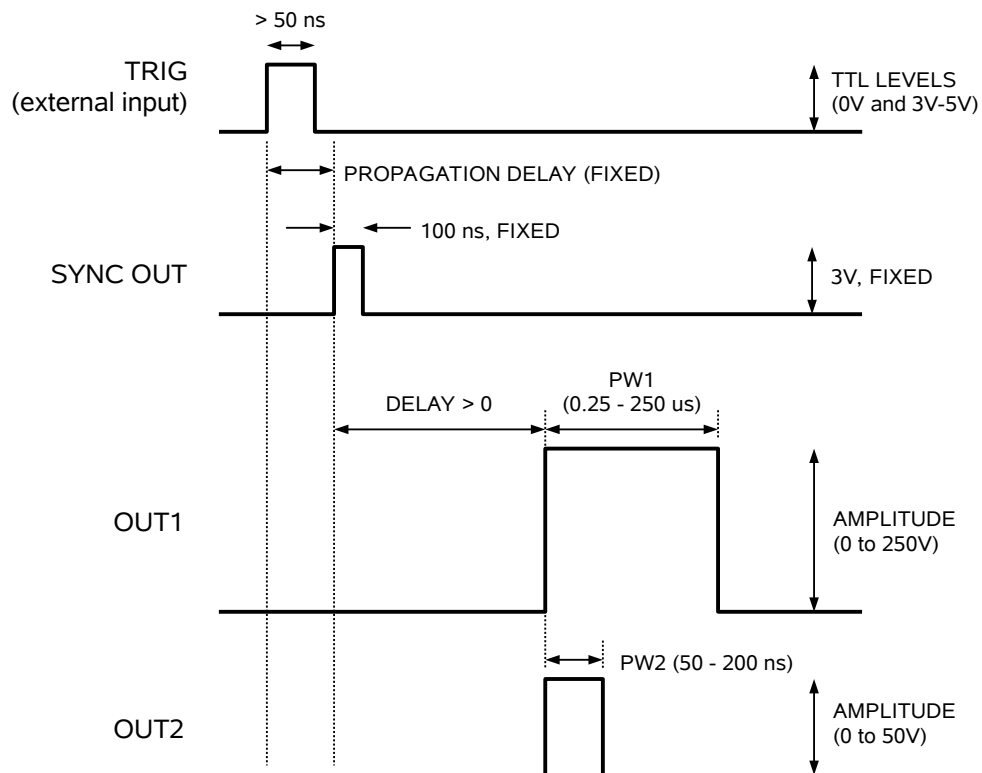

The delay, pulse width, and frequency (when in the internal mode), of the OUT pulse can be varied with front panel controls or via the GPIB or RS-232 computer interfaces.

## TRIGGER MODES

This instrument has four trigger modes:

- Internal Trigger: the instrument controls the trigger frequency, and generates the clock internally.
- External Trigger: the instrument is triggered by an external TTL-level clock on the back-panel TRIG connector.
- Manual Trigger: the instrument is triggered by the front-panel "SINGLE PULSE" pushbutton.
- Hold Trigger: the instrument is set to not trigger at all.

These modes can be selected using the front panel trigger menu, or by using the appropriate programming commands. (See the "Programming Manual for -B Instruments" for more details.)

## GATING MODES

Triggering can be suppressed by a TTL-level signal on the rear-panel GATE connector. The instrument can be set to stop triggering when this input high or low, using the front-panel gate menu or the appropriate programming commands. This input can also be set to act synchronously or asynchronously. When set to asynchronous mode, the GATE will disable the output immediately. Output pulses may be truncated. When set to synchronous mode, the output will complete the full pulse width if the output is high, and then stop triggering. No pulses are truncated in this mode.

## REPLACEMENT CABLES

Each output has a 6" / 15 cm length of RG-316 installed across the "A" and "B" connectors of each module. If these cables become mechanically fatigued due to the repetitive clamping of probes, they may be replaced with 6" inch lengths of SMA-connectorized standard 50 Ohm cable. The recommended replacement part is the Johnson Components (<http://www.johnsoncomponents.com>) 415-0029-006, available readily from Digi-Key (<http://www.digikey.com>, stock number J3706-ND).

The AVX-TEK3-TM1 output module is normally connected to the mainframe using a 12" / 30 cm length of RG-58 coaxial cable. The recommended replacement part is the Johnson Components (<http://www.johnsoncomponents.com>) 415-0054-012, available readily from Digi-Key (<http://www.digikey.com>, stock number J6212-ND).



The AVX-TEK3-TM2 output module is normally connected to the mainframe using a 12" / 30 cm length of RG-316 coaxial cable. The recommended replacement part is the Johnson Components (<http://www.johnsoncomponents.com>) 415-0029-012, available readily from Digi-Key (<http://www.digikey.com>, stock number J3712-ND).

### UNUSED OUTPUTS

OUT1 may be left either connected or unconnected if it is not in use. It will not be harmed by an open circuit, even if the amplitude is not zero.

OUT2 is different. To avoid unnecessarily stressing the internal circuitry, OUT2 should always be terminated with the AVX-TEK3-TM2 output module (with the shorting cable installed), or with a 50 Ohm load. If this is inconvenient, OUT2 may be left unconnected, but the OUT2 amplitude should always be set to zero in this case.

 Do not set the amplitude of OUT2 to a non-zero value if no output module or 50 Ohm load is attached.

## TYPICAL RESULTS

### OUT1

When OUT1 is connected to a 50 Ohm load (using the arrangement shown in the "BASIC TEST ARRANGEMENT, WITHOUT OUTPUT MODULES" section), waveforms similar to the one shown below will be obtained:

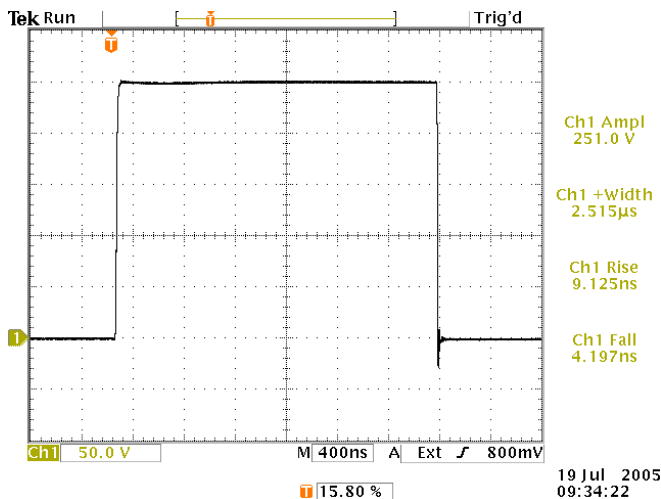

Pulsar settings: 100 Hz, +250V, 2.5 us PW.  
Rise/Fall reference levels: 10%, 90%.

When OUT1 is connected to the AVX-TEK3-TM1 (using the arrangement shown in the "BASIC TEST ARRANGEMENT, WITH OUTPUT MODULES" section) and a Tektronix A6303 probe system, waveforms similar to the one shown below will be obtained:

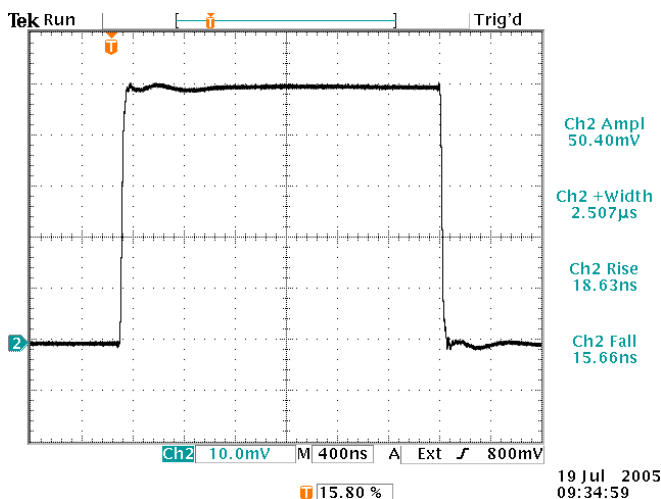

Pulsar settings: 100 Hz, +250V, 2.5 us PW.  
Rise/Fall reference levels: 10%, 90%.  
Probe/scope settings: 10 mV = 1 A.

The probe is slower than the input pulse, so the measured rise time is slower. The probe also introduces a small amount of ringing.

## OUT2

When OUT2 is connected to a high-bandwidth sampling oscilloscope (using the arrangement shown in the "BASIC TEST ARRANGEMENT, WITHOUT OUTPUT MODULES" section), waveforms similar to the one shown below will be obtained:

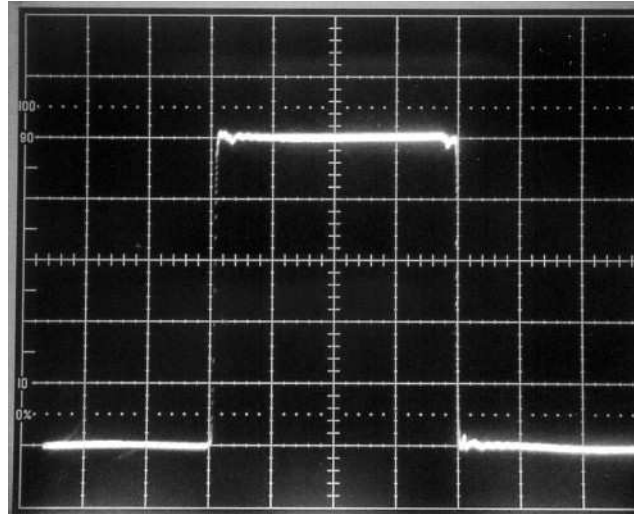

Pulser settings: 10 kHz, +50V, 200 ns PW.  
Scope settings: 10 V/div, 50 ns / div.

The next photo shows the same waveform, with a finer time scale (1 ns/div) to show the very fast rising edge (< 0.5 ns rise time on a 20%-80% basis):

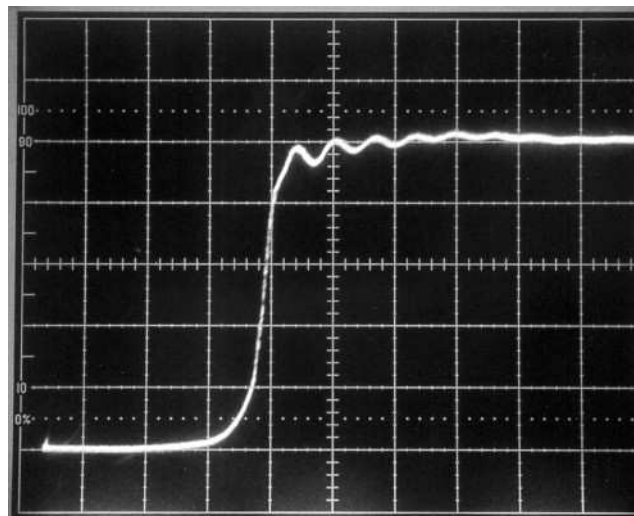

Pulser settings: 10 kHz, +50V, 200 ns PW.  
Scope settings: 10 V/div, 1 ns / div.

When OUT2 is connected to the AVX-TEK3-TM2 (using the arrangement shown in the "BASIC TEST ARRANGEMENT, WITH OUTPUT MODULES" section) and a Tektronix P6042 probe system, waveforms similar to the one shown below will be obtained:

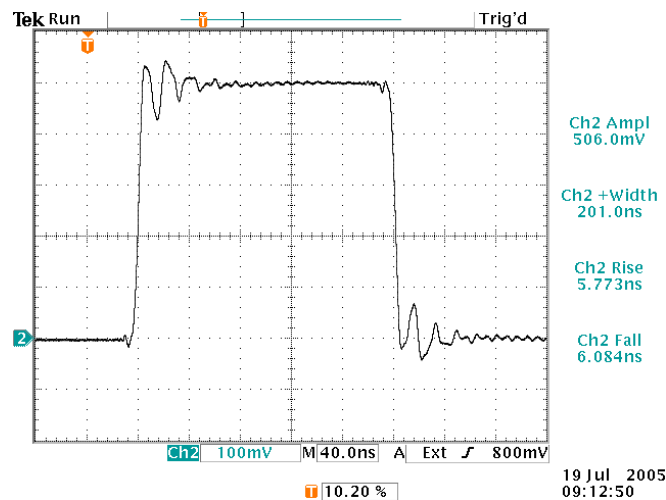

Pulsar settings: 10 kHz, +50V, 200 ns PW.  
Scope settings: 100 mV/div (= 1 A/div), 40 ns / div.

The "shorting cable" that the probe clamps to represents a small discontinuity in the 50 Ohm transmission line, and causes some reflections to occur. These are observed in the above waveforms immediately after the rising and falling edges. The ringing eventually dies out after 80 ns or so. The amplitude and switching times can still be measured accurately. If the ringing is a problem, it can be largely eliminated by adding an attenuator directly on OUT2 SMA connector on the front panel (between the SMA connector and the cable going to the output module). The attenuator will tend to absorb reflections, but it will also reduce the output amplitude. A 6 dB attenuator will reduce the amplitude by half, and produce the following waveform (when used with the P6042 probe system):

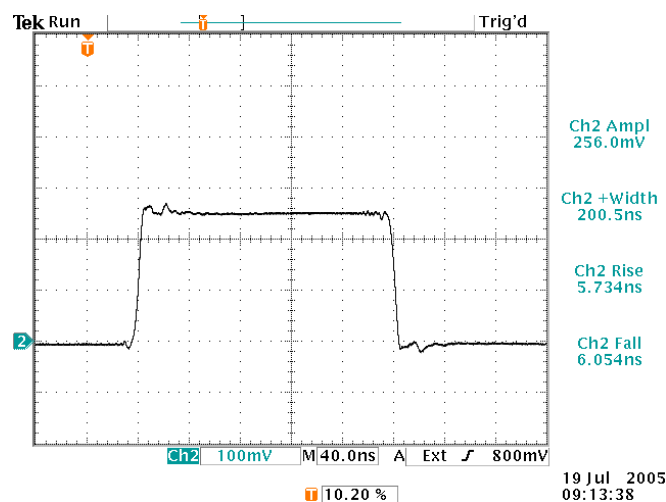

Pulsar settings: 10 kHz, +50V, 200 ns PW.  
Scope settings: 100 mV/div (= 1 A/div), 40 ns / div.

Larger values of attenuation ( $> 6$  dB) will reduce the reflections (and the pulse amplitude) further.

## MEASUREMENT ACCURACY AND CALIBRATION

The AVR-3-PW-TEK3-B is a voltage pulser. The output current is defined by the voltage amplitude and the load resistance.

The voltage amplitude accuracy is specified to be the greater of  $\pm 2\%$  or  $\pm 0.5V$ , when shipped from the factory.

The load resistance is specified to be  $50\Omega \pm 1\%$ , when shipped from the factory.

The as-shipped current amplitude accuracy can thus be estimated as  $\approx \sqrt{(0.02^2 + 0.01^2)}$  = 2.2%.

### VOLTAGE AMPLITUDE CALIBRATION

For applications requiring greater accuracy, the user can observe and calibrate the voltage output. The commands required to update the internal voltage amplitude calibration are described at <http://www.avtechpulse.com/appnote/techbrief5>, in the Technical Brief entitled "How Can I Calibrate the Amplitude and Offset of my Avtech Pulse Generator?".

### LOAD RESISTANCE CALIBRATION

The user can also measure the load resistance between the center conductor of the "B" connector and the outer shield of the "A" connector on each output module, with all cables removed. Beware that the outer shield of the "B" connector is *not* connected to ground. Four-wire measurements must be used for accurate results.

## OPERATIONAL CHECK

This section describes a sequence to confirm the basic operation of the instrument. It should be performed after receiving the instrument. It is a useful learning exercise as well.

Before proceeding with this procedure, finish reading this instruction manual thoroughly. Then read the “Local Control” section of the “Programming Manual for -B Instruments” thoroughly. The “Local Control” section describes the front panel controls used in this operational check - in particular, the MOVE, CHANGE, and ADJUST controls.

1. Connect a cable from the SYNC OUT connector to the TRIG input of an oscilloscope. Connect a 2W (or higher), low-inductance (not wirewound) 50 $\Omega$  load to the OUT1 connector and place the scope probe across this load. Do the same with a second load and probe to the OUT2 connector. Set the oscilloscope to trigger externally with the vertical setting at 20 Volts/div and the horizontal setting at 100 ns/div.

The oscilloscope should have a bandwidth of at least 500 MHz.

2. Turn on the AVR-3-PW-TEK3-B. The main menu will appear on the LCD.
3. To set the AVR-3-PW-TEK3-B to trigger from the internal clock at a PRF of 10 kHz:
  - a) The arrow pointer should be pointing at the frequency menu item. If it is not, press the MOVE button until it is.
  - b) Press the CHANGE button. The frequency submenu will appear. Rotate the ADJUST knob until the frequency is set at 10 kHz.
  - c) The arrow pointer should be pointing at the “Internal” choice. If it is not, press MOVE until it is.
  - d) Press CHANGE to return to the main menu.
4. To set the delay to 100 ns:
  - a) Press the MOVE button until the arrow pointer is pointing at the delay menu item.
  - b) Press the CHANGE button. The delay submenu will appear. Rotate the ADJUST knob until the delay is set at 100 ns.

- c) The arrow pointer should be pointing at the “Normal” choice. If it is not, press MOVE until it is.
  - d) Press CHANGE to return to the main menu.
5. To set the Channel 1 pulse width to 500 ns:
- a) Press the MOVE button until the arrow pointer is pointing at the "PW1" menu item.
  - b) Press the CHANGE button. The pulse width submenu will appear. Rotate the ADJUST knob until the pulse width is set at 500 ns.
  - c) The arrow pointer should be pointing at the “Normal” choice. If it is not, press MOVE until it is.
  - d) Press CHANGE to return to the main menu.
6. To set the Channel 2 pulse width to 200 ns:
- a) Press the MOVE button until the arrow pointer is pointing at the "PW2" menu item.
  - b) Press the CHANGE button. The pulse width submenu will appear. Rotate the ADJUST knob until the pulse width is set at 200 ns.
  - c) The arrow pointer should be pointing at the “Normal” choice. If it is not, press MOVE until it is.
  - d) Press CHANGE to return to the main menu.
7. At this point, nothing should appear on the oscilloscope.
8. To enable the output:
- a) Press the MOVE button until the arrow pointer is pointing at the output menu item.
  - b) Press the CHANGE button. The output submenu will appear.
  - c) Press MOVE until the arrow pointer is pointing at the “ON” choice.
  - d) Press CHANGE to return to the main menu.
9. To change the Channel 1 output amplitude:



- a) Press the MOVE button until the arrow pointer is pointing at the "AMP1" menu item.
  - b) Press the CHANGE button. The amplitude submenu will appear. Rotate the ADJUST knob until the amplitude is set at 250V.
  - c) Observe the oscilloscope. You should see 500 ns wide, 250V pulses.
  - d) Rotate the ADJUST knob. The amplitude as seen on the oscilloscope should vary.
  - e) Press CHANGE to return to the main menu.
10. To change the Channel 2 output amplitude:
- a) Press the MOVE button until the arrow pointer is pointing at the "AMP2" menu item.
  - b) Press the CHANGE button. The amplitude submenu will appear. Rotate the ADJUST knob until the amplitude is set at 50V.
  - c) Observe the oscilloscope. You should see 200 ns wide, 50V pulses. Due to the very fast rise time of this output, some ringing will be observed. This is due to limitations of the oscilloscope, not the pulser. A high-bandwidth sampling oscilloscope may be used to confirm this, if desired.
  - d) Rotate the ADJUST knob. The amplitude as seen on the oscilloscope should vary.
  - e) Press CHANGE to return to the main menu.
11. Try varying the pulse width, by repeating step (6). As you rotate the ADJUST knob, the pulse width on the oscilloscope will change. It should agree with the displayed value.

This completes the operational check.

## PROGRAMMING YOUR PULSE GENERATOR

### KEY PROGRAMMING COMMANDS

The “Programming Manual for -B Instruments” describes in detail how to connect the pulse generator to your computer, and the programming commands themselves. A large number of commands are available; however, normally you will only need a few of these. Here is a basic sample sequence of commands that might be sent to the instrument after power-up:

```
*rst                (resets the instrument)
trigger:source internal (selects internal triggering)
frequency 1000 Hz    (sets the frequency to 1000 Hz)
pulse:width1 1 us    (sets the channel 1 pulse width to 1 us)
pulse:width2 150 ns  (sets the channel 2 pulse width to 150 ns)
pulse:delay 1 us     (sets the inter-channel delay to 1 us)
volt:ampl1 250       (sets the channel 1 amplitude to 250 V)
volt:ampl2 +35       (sets the channel 2 amplitude to 35 V)
output on            (turns on the output)
```

For triggering a single event, this sequence would be more appropriate:

```
*rst                (resets the instrument)
trigger:source hold  (turns off all triggering)
pulse:width1 1 us    (sets the channel 1 pulse width to 1 us)
pulse:width2 150 ns  (sets the channel 2 pulse width to 150 ns)
pulse:delay 1 us     (sets the inter-channel delay to 1 us)
output on            (turns on the output)
volt:ampl1 250       (sets the channel 1 amplitude to 250 V)
volt:ampl2 +35       (sets the channel 2 amplitude to 35 V)
trigger:source immediate (generates a single non-repetitive trigger event)
trigger:source hold  (turns off all triggering)
output off           (turns off the output)
```

To set the instrument to trigger from an external TTL signal applied to the rear-panel TRlg connector, use:

```
*rst                (resets the instrument)
trigger:source external (selects external triggering)
pulse:width1 1 us    (sets the channel 1 pulse width to 1 us)
pulse:width2 150 ns  (sets the channel 2 pulse width to 150 ns)
pulse:delay 1 us     (sets the inter-channel delay to 1 us)
volt:ampl1 250       (sets the channel 1 amplitude to 250 V)
volt:ampl2 +35       (sets the channel 2 amplitude to 35 V)
output on            (turns on the output)
```

These commands will satisfy 90% of your programming needs.

## ALL PROGRAMMING COMMANDS

For more advanced programmers, a complete list of the available commands is given below. These commands are described in detail in the “Programming Manual for -B Instruments”. (Note: this manual also includes some commands that are not implemented in this instrument. They can be ignored.)

<u>Keyword</u>	<u>Parameter</u>	<u>Notes</u>
LOCAL		
OUTPut:		
:[STATe]	<boolean value>	
:PROTection		
:TRIPped?		[query only]
REMOTE		
[SOURce]:		
:FREQuency		
[:CW   FIXed]	<numeric value>	
[SOURce]:		
:PULSe		
:PERiod	<numeric value>	
:WIDTh	<numeric value>	
:DCYCLE	<numeric value>	
:HOLD	WIDTh   DCYCLE	
:DELay	<numeric value>	
:GATE		
:TYPE	ASYNc   SYNc	
:LEVel	HIGH   LOW	
[SOURce]:		
:VOLTage		
[:LEVel]		
[:IMMediate]		
[:AMPLitude]	<numeric value>	
:PROTection		
:TRIPped?		[query only]
STATUS:		
:OPERation		
:[EVENT]?		[query only, always returns "0"]
:CONDition?		[query only, always returns "0"]
:ENABle	<numeric value>	[implemented but not useful]
:QUESTionable		
:[EVENT]?		[query only, always returns "0"]
:CONDition?		[query only, always returns "0"]
:ENABle	<numeric value>	[implemented but not useful]
SYSTEM:		
:COMMunicate		
:GPIB		
:ADDReSS	<numeric value>	
:SERial		
:CONTRol		

:RTS	ON   IBFull   RFR	
:[RECeive]		
:BAUD	1200   2400   4800   9600	
:BITS	7   8	
:ECHO	<boolean value>	
:PARity		
:[TYPE]	EVEN   ODD   NONE	
:SBITS	1   2	
:ERRor		
:[NEXT]?		[query only]
:COUNT?		[query only]
:VERSion?		[query only]
TRIGger:		
:SOURce	INTernal   EXTernal   MANual   HOLD   IMMEDIATE	
*CLS		[no query form]
*ESE	<numeric value>	
*ESR?		[query only]
*IDN?		[query only]
*OPC		
*SAV	0   1   2   3	[no query form]
*RCL	0   1   2   3	[no query form]
*RST		[no query form]
*SRE	<numeric value>	
*STB?		[query only]
*TST?		[query only]
*WAI		[no query form]

## MECHANICAL INFORMATION

### TOP COVER REMOVAL

If necessary, the interior of the instrument may be accessed by removing the four Phillips screws on the top panel. With the four screws removed, the top cover may be slid back (and off).

 Always disconnect the power cord and allow the instrument to sit unpowered for 10 minutes before opening the instrument. This will allow any internal stored charge to discharge.

There are no user-adjustable internal circuits. For repairs other than fuse replacement, please contact Avtech (info@avtechpulse.com) to arrange for the instrument to be returned to the factory for repair. Service is to be performed solely by qualified service personnel.

 Caution: High voltages are present inside the instrument during normal operation. Do not operate the instrument with the cover removed.

### RACK MOUNTING

A rack mounting kit is available. The -R5 rack mount kit may be installed after first removing the one Phillips screw on the side panel adjacent to the front handle.

### ELECTROMAGNETIC INTERFERENCE

To prevent electromagnetic interference with other equipment, all used outputs should be connected to shielded loads using shielded coaxial cables. Unused outputs should be terminated with shielded coaxial terminators or with shielded coaxial dust caps, to prevent unintentional electromagnetic radiation. All cords and cables should be less than 3m in length.

## MAINTENANCE

### REGULAR MAINTENANCE

This instrument does not require any regular maintenance.

On occasion, one or more of the four rear-panel fuses may require replacement. All fuses can be accessed from the rear panel. See the “FUSES” section for details.

### CLEANING

If desired, the interior of the instrument may be cleaned using compressed air to dislodge any accumulated dust. (See the “TOP COVER REMOVAL” section for instructions on accessing the interior.) No other cleaning is recommended.

# WIRING DIAGRAMS

## WIRING OF AC POWER

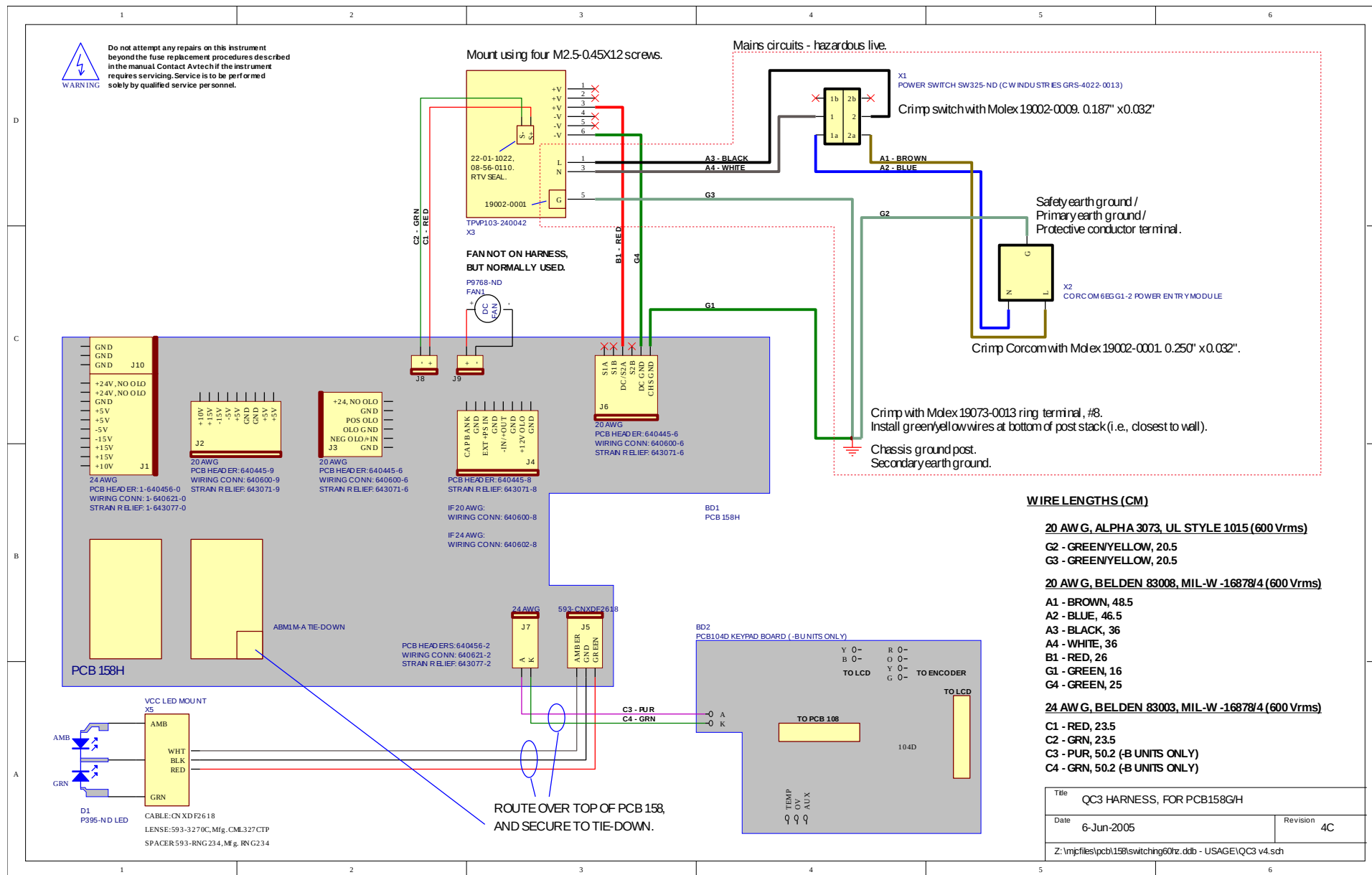

# PCB 158H - LOW VOLTAGE POWER SUPPLY, 1/3

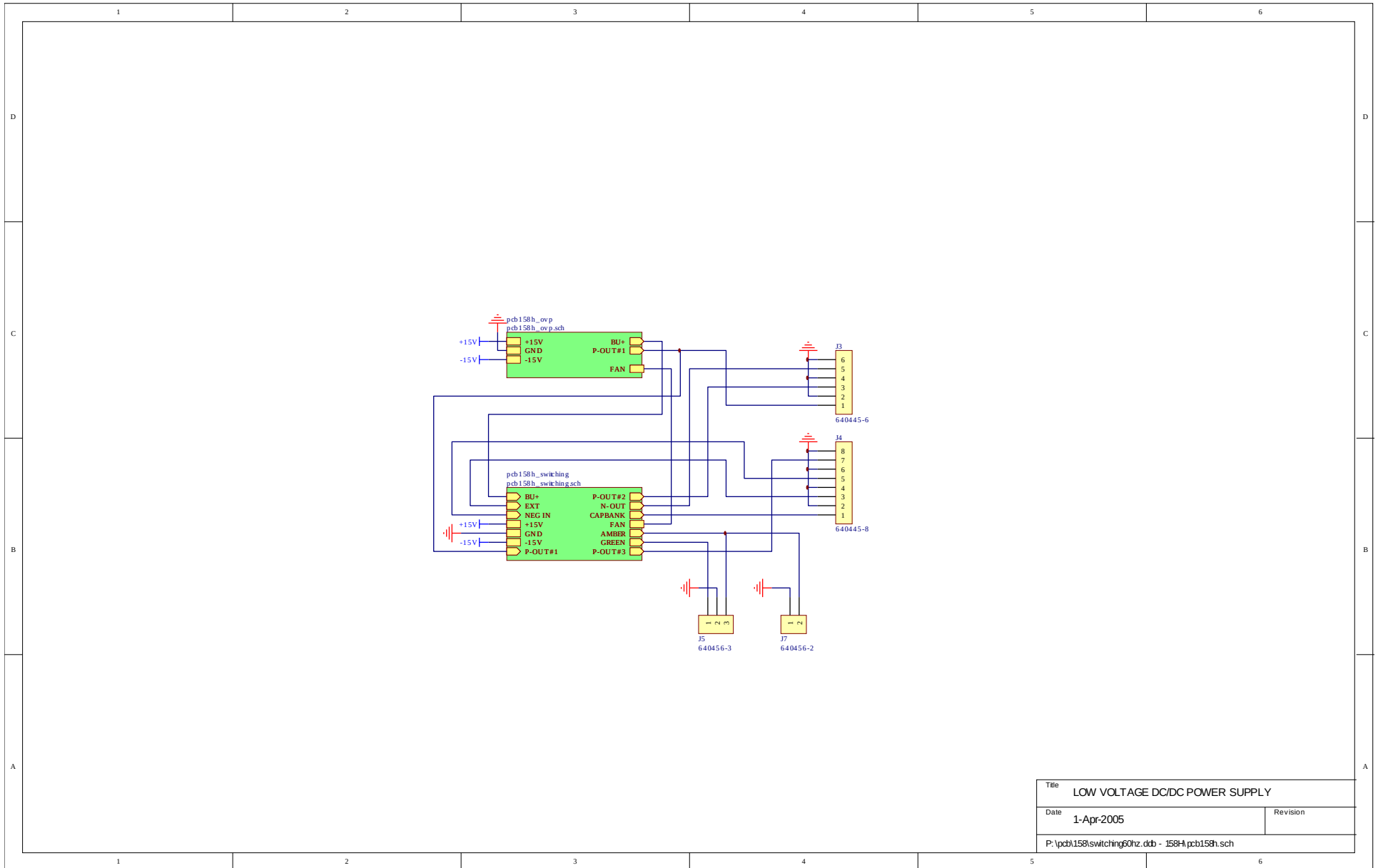

Title		LOW VOLTAGE DC/DC POWER SUPPLY
Date	1-Apr-2005	Revision
P:\pcb\158\switching60hz.ddb - 158H.pcb158h.sch		



# PCB 158H - LOW VOLTAGE POWER SUPPLY, 2/3

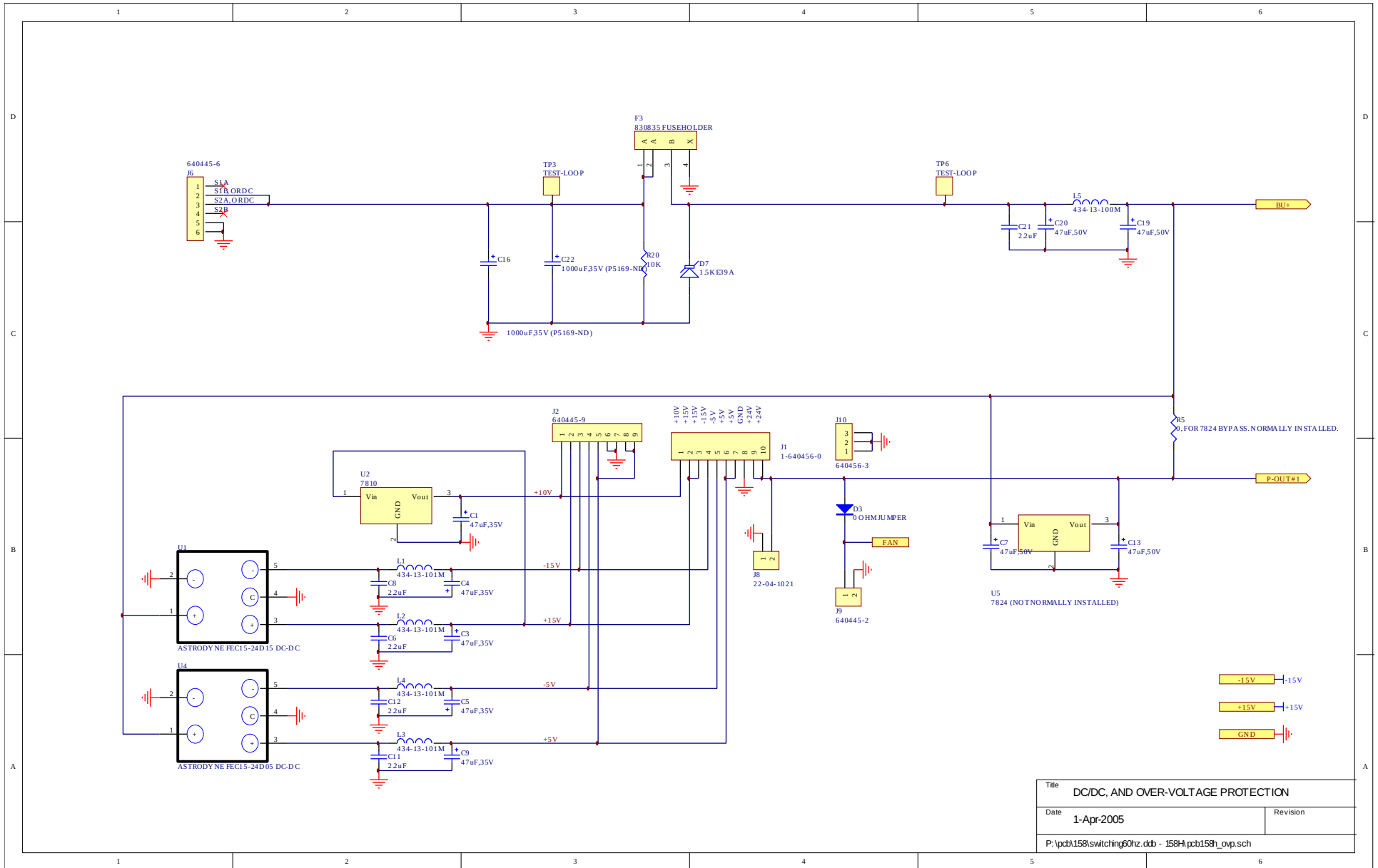

# PCB 158H - LOW VOLTAGE POWER SUPPLY, 3/3

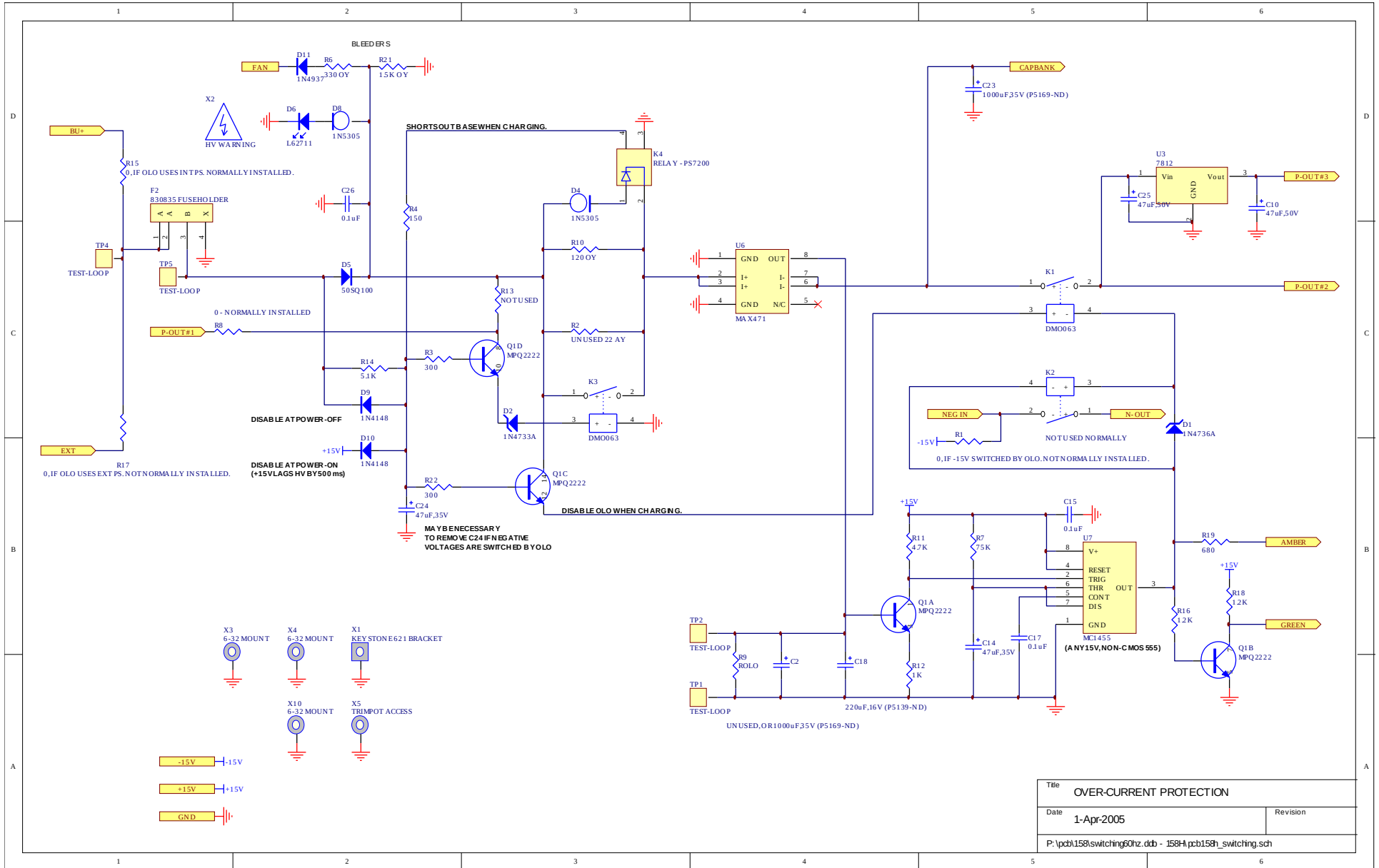





# PCB 183A - CAPACITOR BANKS

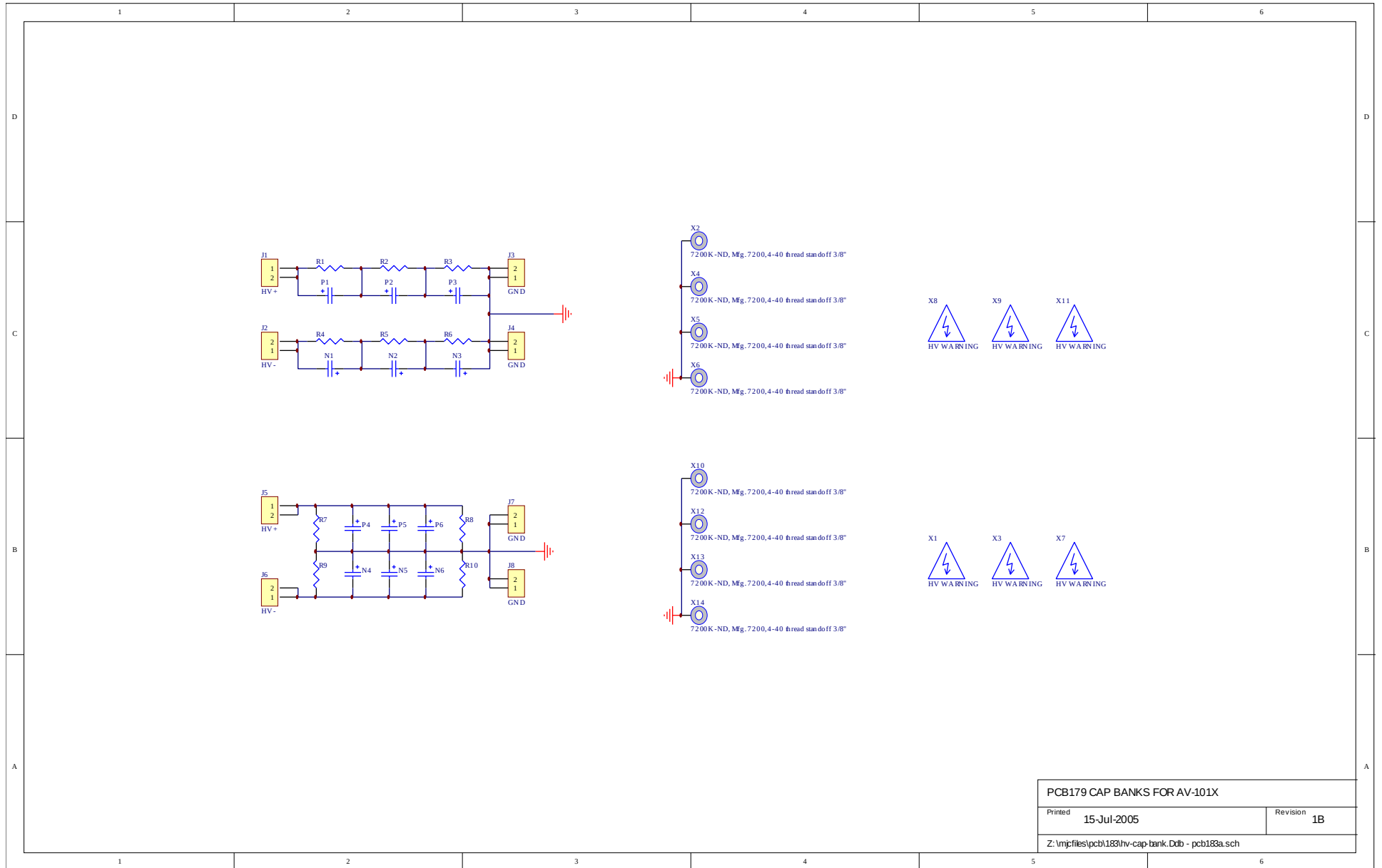

PCB179 CAP BANKS FOR AV-101X	
Printed 15-Jul-2005	Revision 1B
Z:\mpjfiles\pcb183\hv-cap-bank.Dtb - pcb183a.sch	

# PCB 174 - DUAL CHANNEL PULSE WIDTH BOARD

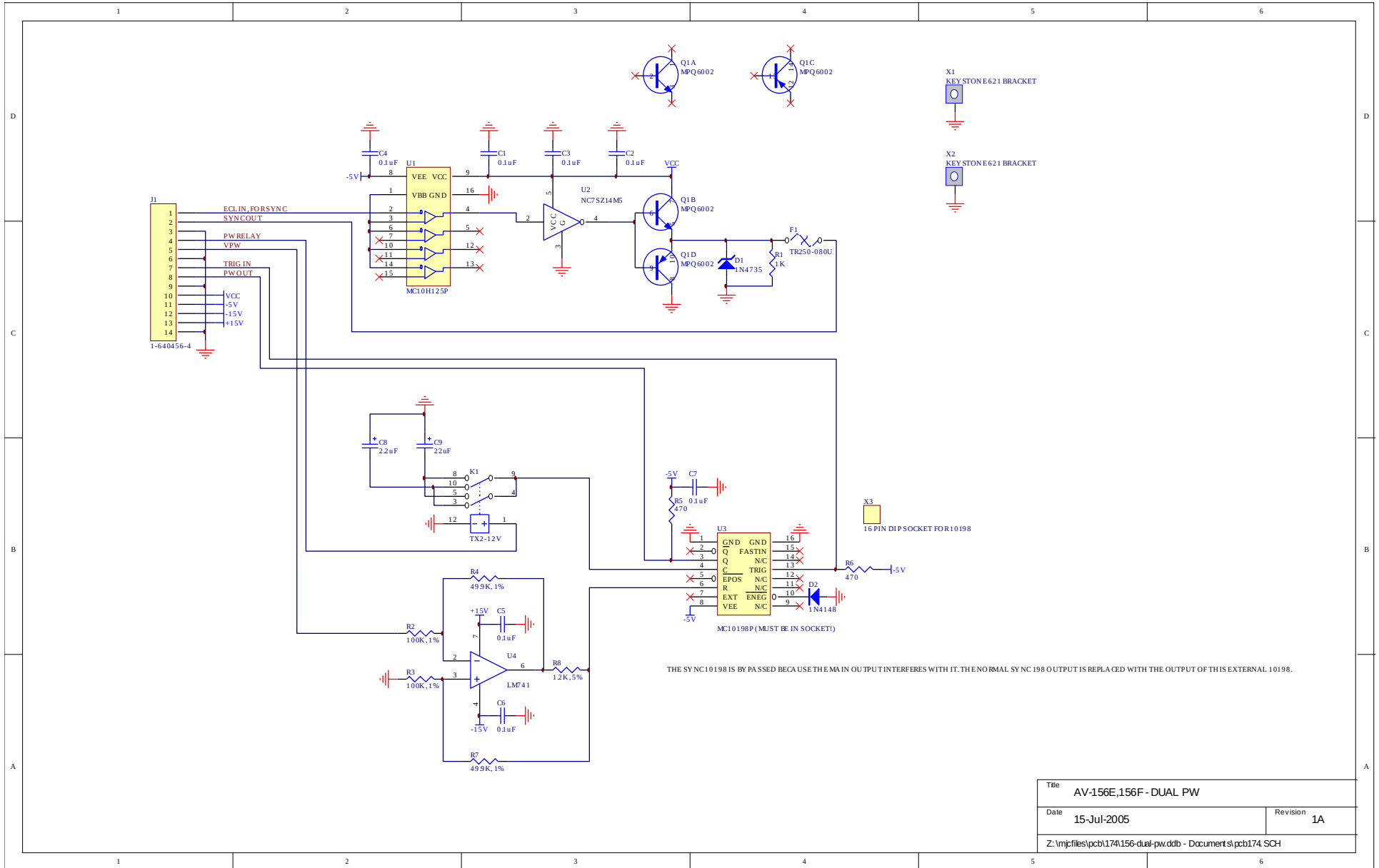

# PCB 104D - KEYPAD / DISPLAY BOARD, 1/3



Title		PANEL TOP-LEVEL SCHEMATIC	
Date	17-Dec-2004	Revision	
P:\pcb\104d\keypad\2004.DDB - Documents\Panelbrd.prj			

# PCB 104D - KEYPAD / DISPLAY BOARD, 2/3

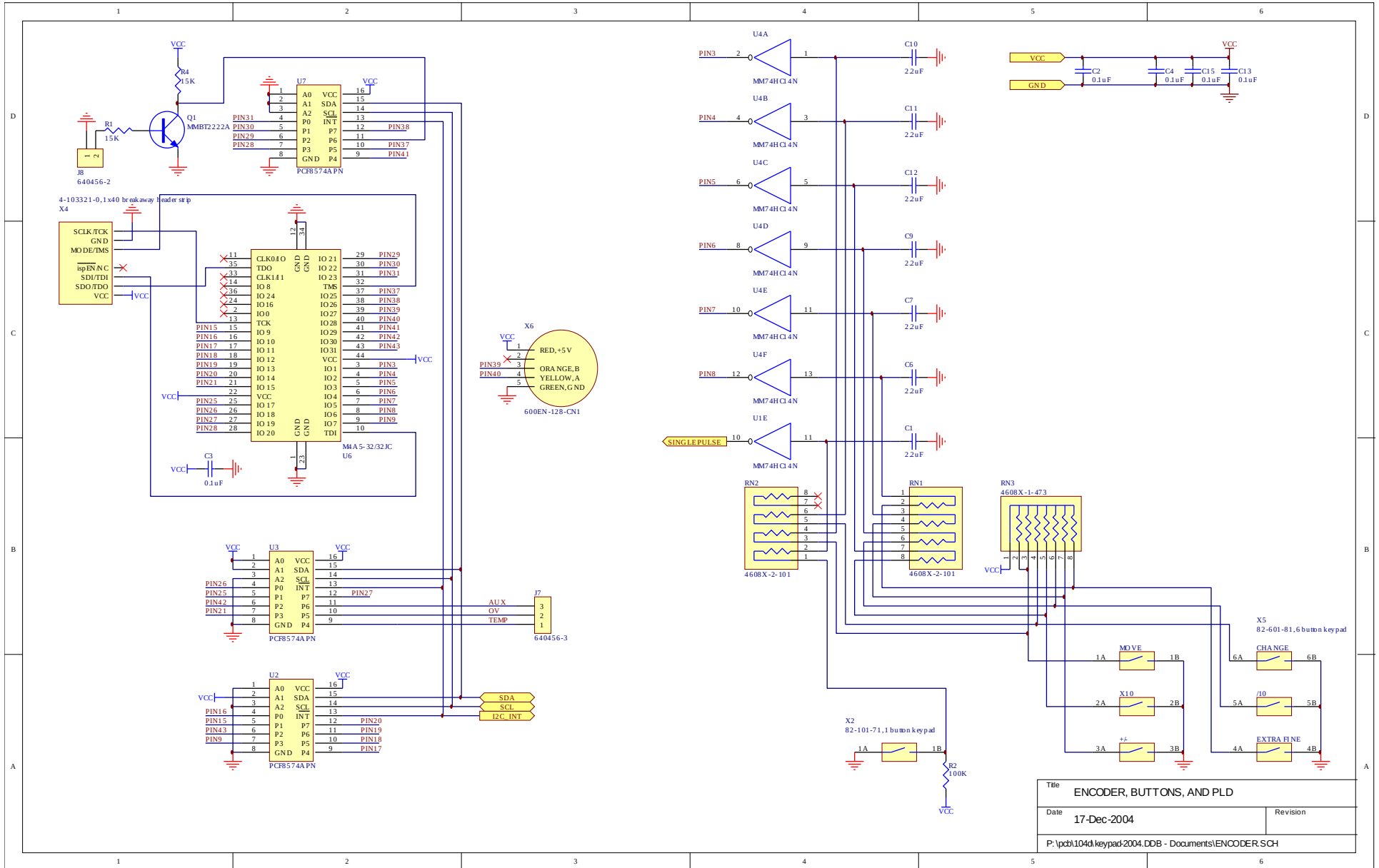



# PCB 104D - KEYPAD / DISPLAY BOARD, 3/3

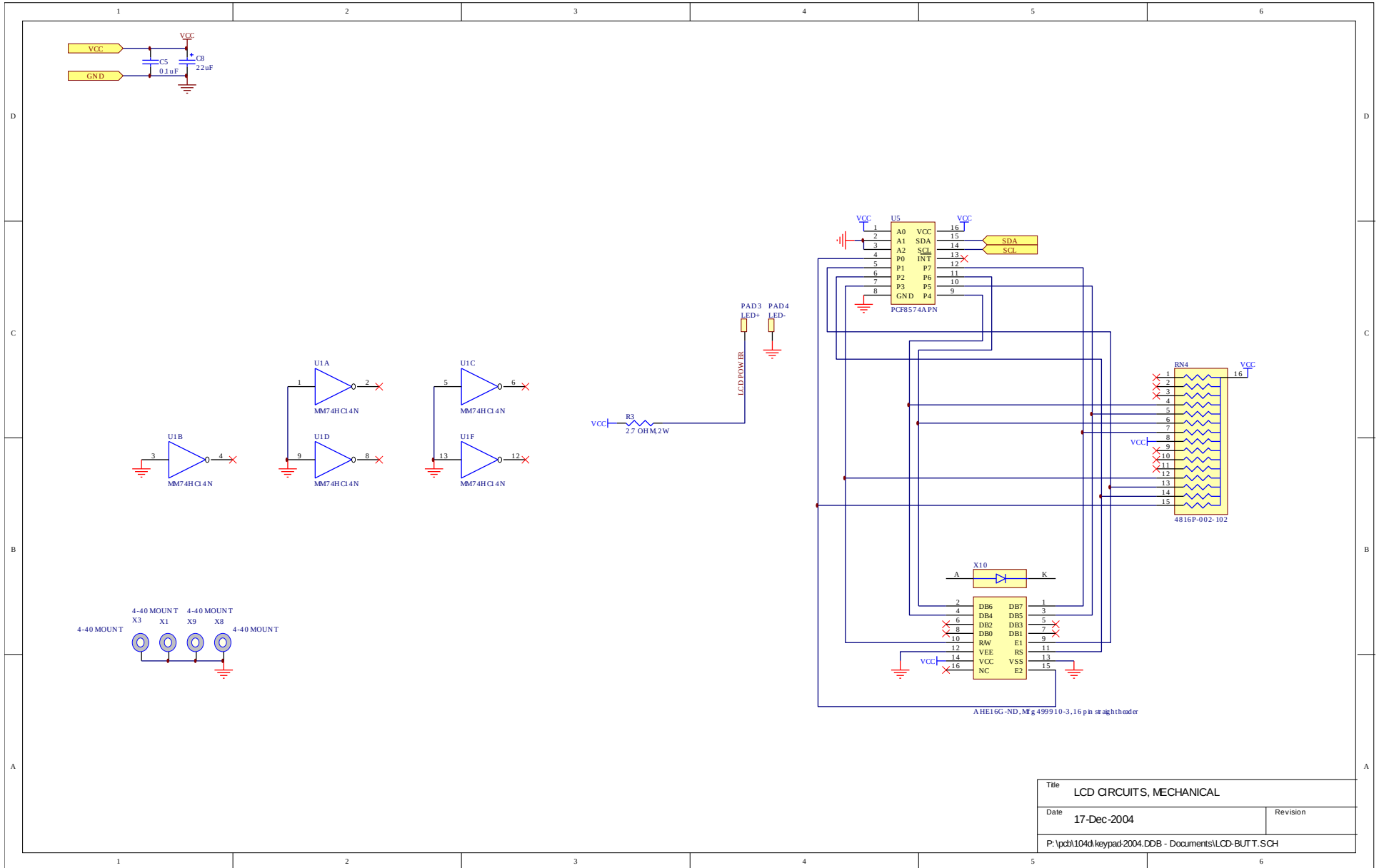

# MAIN WIRING (-P UNITS)

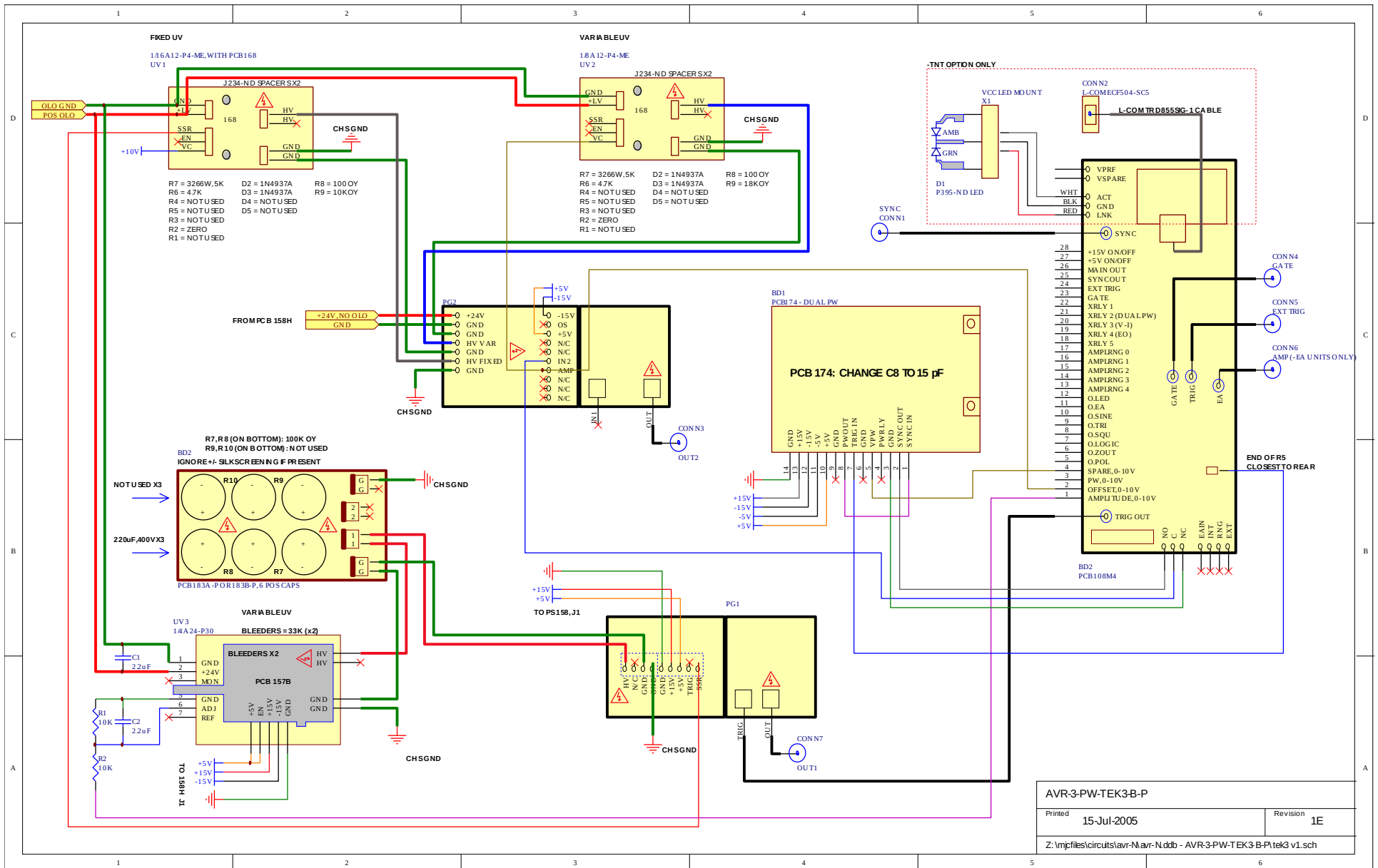

PERFORMANCE CHECK SHEET