

INSTRUCTIONS

MODEL AVR-4A-PW-C-PN-OP1B

0 TO \pm 400 VOLTS, 10 kHz
PULSE GENERATOR
WITH IEEE 488.2 AND RS-232 CONTROL

SERIAL NUMBER: _____

WARRANTY

Avtech Electrosystems Ltd. warrants products of its manufacture to be free from defects in material and workmanship under conditions of normal use. If, within one year after delivery to the original owner, and after prepaid return by the original owner, this Avtech product is found to be defective, Avtech shall at its option repair or replace said defective item. This warranty does not apply to units which have been disassembled, modified or subjected to conditions exceeding the applicable specifications or ratings. This warranty is the extent of the obligation assumed by Avtech with respect to this product and no other warranty or guarantee is either expressed or implied.

TECHNICAL SUPPORT

Phone: 613-226-5772 or 1-800-265-6681

Fax: 613-226-2802 or 1-800-561-1970

E-mail: info@avtechpulse.com

World Wide Web: <http://www.avtechpulse.com>

TABLE OF CONTENTS

WARRANTY	2
TECHNICAL SUPPORT	2
TABLE OF CONTENTS	3
INTRODUCTION	5
MODEL NUMBER CHANGE	5
SPECIFICATIONS	6
INSTALLATION	7
VISUAL CHECK	7
PLUGGING IN THE INSTRUMENT	7
FRONT PANEL CONTROLS	8
REAR PANEL CONTROLS	10
GENERAL INFORMATION	11
BASIC PULSE CONTROL	11
TRIGGER MODES	13
PULSE WIDTH MODES	13
GATING MODES	13
OUTPUT IMPEDANCE	14
TOP COVER REMOVAL	14
ELECTROMAGNETIC INTERFERENCE	14
RACK MOUNTING	14
PROTECTING YOUR INSTRUMENT AND LOAD	15
DO NOT EXCEED 0.5% DUTY CYCLE	15
KEEP THE LOAD IMPEDANCE ABOVE OR EQUAL TO 50	15
REDUCE AMPLITUDE BEFORE SWITCHING POLARITY	15
OPERATE AT LOW DUTY CYCLE AND PRF	15
NEVER ADD A DC POTENTIAL TO THE OUTPUT	15
OPERATIONAL CHECK	16
PROGRAMMING YOUR PULSE GENERATOR	19
KEY PROGRAMMING COMMANDS	19
ALL PROGRAMMING COMMANDS	20
REPAIR PROCEDURES	22
PERFORMANCE CHECK SHEET	24

INTRODUCTION

The AVR-4A-PW-C-PN-OP1B is a high performance, GPIB and RS232-equipped instrument generating pulses of up to ± 400 V in amplitude into loads as low as 50Ω , at repetition rates up to 10 kHz. The pulse width is variable from 50 ns to 5us, with a 0.5% duty cycle limit. Rise and fall times are fixed at less than 20 ns. The AVR-4A-PW-C-PN-OP1B can be triggered from an internal source, and can also be triggered or gated by an external source. A front-panel pushbutton can also be used to trigger the instrument. The output pulse width can be set to follow an input trigger pulse.

The AVR-4A-PW-C-PN-OP1B features front panel keyboard and adjust knob control of the output pulse parameters along with a four line by 40 character back-lit LCD display of the output amplitude, polarity, pulse width, pulse repetition frequency, source resistance and delay. The instrument includes memory to store up to four complete instrument setups. The operator may use the front panel or the computer interface to store a complete "snapshot" of all key instrument settings, and recall this setup at a later time.

MODEL NUMBER CHANGE

Please note that the "-C-OP1B" suffix in Avtech model numbers will be shortened in the future to "-B". To re-order this instrument in the future, order "AVR-4A-PW-PN-B". This is a change in nomenclature only, and not a change in functionality.

SPECIFICATIONS

Model:	AVR-4A-PW-C-PN-OP1B
Pulse output amplitude ¹ : ($R_L \geq 50 \Omega$)	0 to ± 400 Volts
Rise time, fall time:	≤ 20 ns
Pulse width ² :	50 ns to 5 μ s
Pulse repetition rate:	1 Hz to 10 kHz
GPIB control:	Included as a standard feature.
Maximum duty cycle:	0.5%
Average power out:	12 Watts
Output polarity:	Positive or negative
Propagation delay, external trigger modes:	≤ 100 ns (ext trig in to pulse out)
Jitter:	100 ps (ext trig in to pulse out)
External trigger:	+5V, 50 ns or wider (TTL)
Sync output:	+3 Volts, 200 ns, will drive 50 Ohm loads
Sync delay:	Variable 0 to ± 5 μ s (between sync out and main pulse output)
Gated operation:	Has a programmable high/low synchronous/asynchronous gate
Connectors:	BNC female
Power source:	120/240 Volts, switchable 50-60 Hz
Operating temperature:	+ 15° C to + 40° C

INSTALLATION

VISUAL CHECK

After unpacking the instrument, examine to ensure that it has not been damaged in shipment. Visually inspect all connectors, knobs, liquid crystal displays (LCDs), and the handles. Confirm that a power cord and two instrumentation manuals (this manual and the "OP1B Interface Programming Manual") are with the instrument. If the instrument has been damaged, file a claim immediately with the company that transported the instrument.

PLUGGING IN THE INSTRUMENT

Examine the rear of the instrument. There will be a male power receptacle, a fuse holder and the edge of the power selector card visible. Confirm that the power selector is in the correct orientation - it should be marked either 120 or 240, indicating whether it expects 120V AC or 240V AC. If it is not set for the proper voltage, remove the fuse and then grasp the card with a pair of pliers and remove it. Rotate horizontally through 180 degrees. Reinstall the card and the correct fuse. In the 120V setting, a 1.0A slow blow fuse is required. In the 240V setting, a 1/2A slow blow fuse is required.

FRONT PANEL CONTROLS

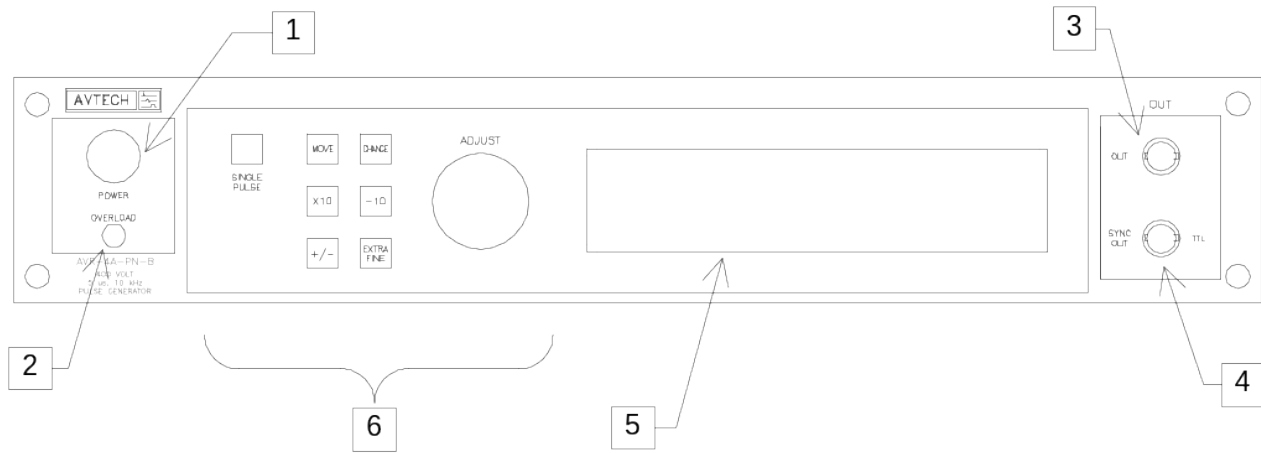

- 1) **POWER Switch.** The POWER push button switch applies AC prime power to the primaries of the transformer, turning the instrument on. The push button lamp (#382 type) is connected to the internal +15V DC supply.
- 2) **OVERLOAD.** The AVR-4A-PW-C-PN-OP1B is protected in its internal software against conflicting or dangerous settings. As an additional protective measure, an automatic overload circuit exists, which controls the front panel overload light. If the unit is overloaded (by operating at an exceedingly high duty cycle or by operating into a very low impedance), the protective circuit will turn the output of the instrument OFF and turn the indicator light ON. The light will stay ON (i.e. output OFF) for about 5 seconds after which the instrument will attempt to turn ON (i.e. light OFF) for about 1 second. If the overload condition persists, the instrument will turn OFF again (i.e. light ON) for another 5 seconds. If the overload condition has been removed, the instrument will turn on and resume normal operation.

Overload conditions may be removed by:

- a) Reducing PRF (pulse repetition frequency)
- b) Reducing pulse width
- c) Removing output load short circuit (if any)

This overload indicator may come on briefly at startup. This is not a cause for concern.

- 3) **OUT CONNECTOR.** This BNC connector provides the main output signal, into load impedances of 50Ω or higher.
- 4) **SYNC OUT.** This connector supplies a SYNC output that can be used to trigger other equipment, particularly oscilloscopes. This signal leads (or lags) the main

output by a duration set by the "DELAY" controls and has an approximate amplitude of +3 Volts to $R_L > 1k\Omega$ with a pulse width of approximately 200 ns.

- 5) LIQUID CRYSTAL DISPLAY (LCD). This LCD is used in conjunction with the keypad to change the instrument settings. Normally, the main menu is displayed, which lists the key adjustable parameters and their current values. The "OP1B Interface Programming Manual" describes the menus and submenus in detail.
- 6) KEYPAD.

Control Name	Function
MOVE	This moves the arrow pointer on the display.
CHANGE	This is used to enter the submenu, or to select the operating mode, pointed to by the arrow pointer.
×10	If one of the adjustable numeric parameters is displayed, this increases the setting by a factor of ten.
÷10	If one of the adjustable numeric parameters is displayed, this decreases the setting by a factor of ten.
+/-	If one of the adjustable numeric parameters is displayed, and this parameter can be both positive or negative, this changes the sign of the parameter.
EXTRA FINE	This changes the step size of the ADJUST knob. In the extra-fine mode, the step size is twenty times finer than in the normal mode. This button switches between the two step sizes.
ADJUST	This large knob adjusts the value of any displayed numeric adjustable values, such as frequency, pulse width, etc. The adjust step size is set by the "EXTRA FINE" button. When the main menu is displayed, this knob can be used to move the arrow pointer.

REAR PANEL CONTROLS



1. AC POWER INPUT. A three-pronged recessed male connector is provided on the back panel for AC power connection to the instrument. Also contained in this assembly is a 1.0A slow blow fuse and a removable card that can be removed and repositioned to switch between 120V AC in and 240V AC in.
2. 1.5A SB. This fuse protects the output stage if the output duty cycle rating is exceeded.
3. GATE. This TTL-level (0 and +5V) logic input can be used to gate the triggering of the instrument. This input can be either active high or active low, depending on the front panel settings or programming commands. (The instrument triggers normally when this input is unconnected).
4. TRIG. This TTL-level (0 and +5V) logic input can be used to trigger the instrument, if the instrument is set to triggering externally. The instrument triggers on the rising edge of this input. The instrument can also be set such that the output pulse width tracks the pulse width on this input, or the output pulse width can be set independently.
5. GPIB Connector. A standard GPIB cable can be attached to this connector to allow the instrument to be computer-controlled. See the "OP1B Interface Programming Manual" for more details on GPIB control.
6. RS-232 Connector. A standard serial cable with a 25-pin male connector can be attached to this connector to allow the instrument to be computer-controlled. See the "OP1B Interface Programming Manual" for more details on RS-232 control.

GENERAL INFORMATION

BASIC PULSE CONTROL

This instrument can be triggered by its own internal clock or by an external TTL trigger signal. In either case, two output channels respond to the trigger: OUT and SYNC. The OUT channel is the signal that is applied to the load. Its amplitude and pulse width are variable. The SYNC pulse is a fixed-width TTL-level reference pulse used to trigger oscilloscopes or other measurement systems. When the delay is set to a positive value the SYNC pulse precedes the OUT pulse. When the delay is set to a negative value the SYNC pulse follows the OUT pulse.

These pulses are illustrated below, assuming internal triggering and a positive delay:

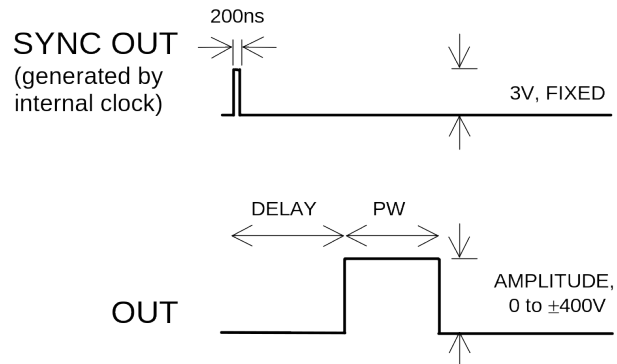

Figure A

If the delay is negative, the order of the SYNC and OUT pulses is reversed:

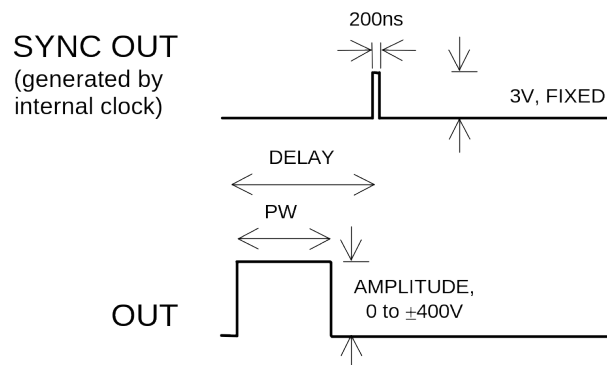

Figure B

The next figure illustrates the relationship between the signal when an external TTL-level trigger is used:

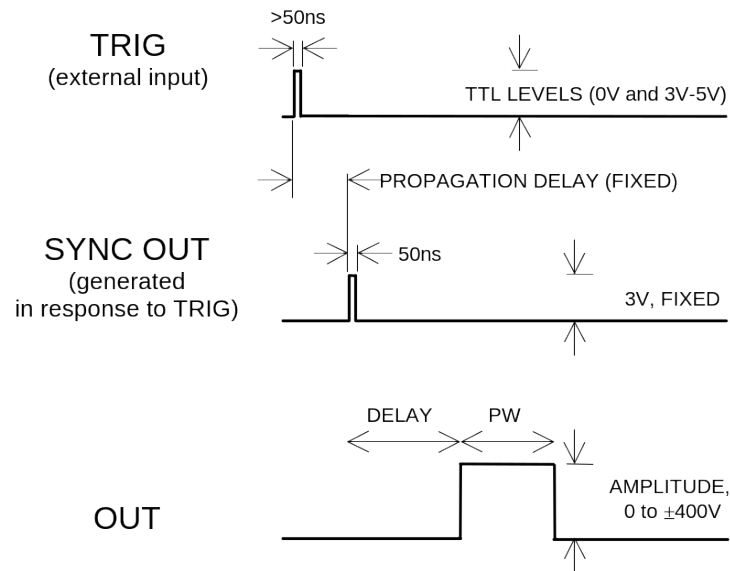

Figure C

As before, if the delay is negative, the order of the SYNC and OUT pulses is reversed.

The last figure illustrates the relationship between the signal when an external TTL-level trigger is used in the $PW_{IN}=PW_{OUT}$ mode. In this case, the output pulse width equals the external trigger's pulse width (approximately), and the delay circuit is bypassed:

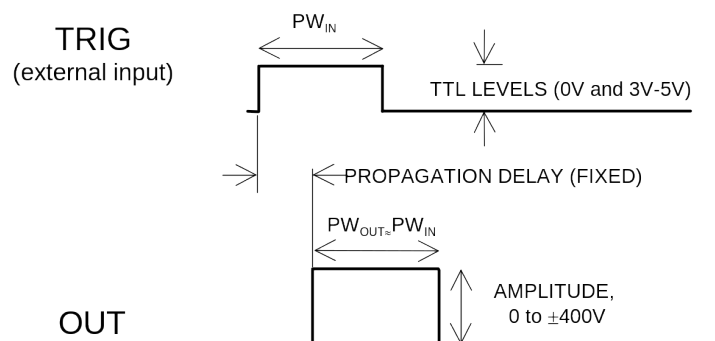

Figure D

The delay, pulse width, and frequency (when in the internal mode), of the OUT pulse can be varied with front panel controls or via the GPIB or RS-232 computer interfaces.

TRIGGER MODES

This instrument has four trigger modes:

- Internal Trigger: the instrument controls the trigger frequency, and generates the clock internally.
- External Trigger: the instrument is triggered by an external TTL-level clock on the back-panel TRIG connector.
- Manual Trigger: the instrument is triggered by the front-panel “SINGLE PULSE” pushbutton.
- Hold Trigger: the instrument is set to not trigger at all.

These modes can be selected using the front panel trigger menu, or by using the appropriate programming commands. (See the “OP1B Interface Programming Manual” for more details.)

PULSE WIDTH MODES

This instrument has two pulse width modes:

- Normal: the instrument controls the output pulse width.
- $PW_{IN}=PW_{OUT}$: the output pulse width equals the pulse width of the trigger signal on the “TRIG” connector. The instrument must be in the external trigger mode.

These modes can be selected using the front panel pulse width menu, or by using the appropriate programming commands. (See the “OP1B Interface Programming Manual” for more details.)

GATING MODES

Triggering can be suppressed by a TTL-level signal on the rear-panel GATE connector. The instrument can be set to stop triggering when this input high or low, using the front-panel gate menu or the appropriate programming commands. This input can also be set to act synchronously or asynchronously. When set to asynchronous mode, the GATE will disable the output immediately. Output pulses may be truncated. When set to synchronous mode, the output will complete the full pulse width if the output is high, and then stop triggering. No pulses are truncated in this mode.

OUTPUT IMPEDANCE

The AVR-4A-C features an output impedance of the order of several Ohms (rather than 50 Ohms). The following consequences of this feature should be noted:

- When used to switch some semiconductor devices (e.g. bipolar and VMOS power transistors), the AVR unit will yield much faster switching times than those provided by 50 Ohm pulse generators.
- The AVR unit will safely operate in to load impedances in the range of 50 Ohms to an open circuit. However, the fall time may degrade for load impedances higher than fifty Ohms.
- The AVR unit may be effectively converted to a fifty Ohm output impedance generator by placing a fifty Ohm carbon composition resistor in series with the output of the unit and the load. The maximum available load voltage will then decrease to 200 Volts for a fifty Ohm load, but will still be 400V for a high impedance load. Note that the addition of a 50 Ohm series back-matching resistor may be necessary when driving high impedance loads to eliminate ringing and overshoot on the leading and falling edges.
- The output switching elements may fail if the unit is inadvertently operated into a short circuit.

TOP COVER REMOVAL

The interior of the instrument may be accessed by removing the four Phillips screws on the top panel. With the four screws removed, the top cover may be slid back (and off).

ELECTROMAGNETIC INTERFERENCE

To prevent electromagnetic interference with other equipment, all used outputs should be connected to shielded 50 Ω loads using shielded 50 Ω coaxial cables. Unused outputs should be terminated with shielded 50 Ω BNC terminators or with shielded BNC dust caps, to prevent unintentional electromagnetic radiation. All cords and cables should be less than 3m in length.

RACK MOUNTING

A rack mounting kit is available. The -R5 rack mount kit may be installed after first removing the one Phillips screw on the side panel adjacent to the front handle.

PROTECTING YOUR INSTRUMENT AND LOAD

DO NOT EXCEED 0.5% DUTY CYCLE

When triggering internally, the instrument will automatically prohibit conflicting settings. However, when triggering externally the user must take care to ensure that the output duty cycle does not exceed 0.5%, or the output stage may be damaged

KEEP THE LOAD IMPEDANCE ABOVE OR EQUAL TO 50Ω

The output switching elements may fail if the unit is inadvertently operated into a short circuit, or load impedances less than 50Ω.

REDUCE AMPLITUDE BEFORE SWITCHING POLARITY

Before switching output polarity, it is recommended that the amplitude be reduced to near zero, if possible. This will reduce stress on internal circuitry.

OPERATE AT LOW DUTY CYCLE AND PRF

The output stage is protected against overload condition by 2.5 A slow blow fuse on the main frame back panel. However, the output switching elements may fail if the unit is triggered at a PRF exceeding 10 kHz or at duty cycles resulting in an average output power in excess of 12 Watts. Heating and subsequent possibility of failure of the output stage is reduced if the following actions are taken, where possible:

- PRF is kept to a minimum, i.e. operate in a low PRF range when possible rather than in a high PRF range.
- Keep the output PW to a minimum.

NEVER ADD A DC POTENTIAL TO THE OUTPUT

Do not, under any circumstances, connect a DC voltage directly to the output of this instrument. Do not attempt to add an offset in this manner.

OPERATIONAL CHECK

This section describes a sequence to confirm the basic operation of the instrument. It should be performed after receiving the instrument. It is a useful learning exercise as well.

Before proceeding with this procedure, finish reading this instruction manual thoroughly. Then read the “Local Control” section of the “OP1B Interface Programming Manual” thoroughly. The “Local Control” section describes the front panel controls used in this operational check - in particular, the MOVE, CHANGE, and ADJUST controls.

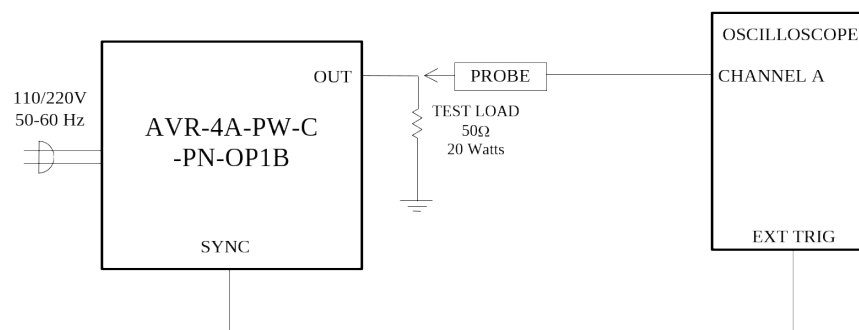

BASIC TEST ARRANGEMENT

1. Connect a cable from the SYNC OUT connector to the TRIG input of an oscilloscope. Connect a 20W (or higher) 50Ω load to the OUT connector and place the scope probe across this load. Note that the load and the probe must be rated for operation at 400V and above. Set the oscilloscope to trigger externally with the vertical setting at 50 Volts/div and the horizontal setting at 1 us/div.
2. Turn on the AVR-4A-PW-C-PN-OP1B. The main menu will appear on the LCD. (If nothing appears, rotate the CONTRAST knob fully clockwise.)
3. Make sure that the HV switch on the rear panel is set to the “ON” position.
4. To set the AVR-4A-PW-C-PN-OP1B to trigger from the internal clock at a PRF of 1kHz:
 - a) The arrow pointer should be pointing at the frequency menu item. If it is not, press the MOVE button until it is.

- b) Press the CHANGE button. The frequency submenu will appear. Rotate the ADJUST knob until the frequency is set at 1 kHz.
 - c) The arrow pointer should be pointing at the “Internal” choice. If it is not, press MOVE until it is.
 - d) Press CHANGE to return to the main menu.
5. To set the delay to 1 μ s:
- a) Press the MOVE button until the arrow pointer is pointing at the delay menu item.
 - b) Press the CHANGE button. The delay submenu will appear. Rotate the ADJUST knob until the delay is set at 1 μ s.
 - c) The arrow pointer should be pointing at the “Normal” choice. If it is not, press MOVE until it is.
 - d) Press CHANGE to return to the main menu.
6. To set the pulse width to 1 μ s:
- a) Press the MOVE button until the arrow pointer is pointing at the pulse width menu item.
 - b) Press the CHANGE button. The pulse width submenu will appear. Rotate the ADJUST knob until the pulse width is set at 1 μ s.
 - c) The arrow pointer should be pointing at the “Normal” choice. If it is not, press MOVE until it is.
 - d) Press CHANGE to return to the main menu.
7. At this point, nothing should appear on the oscilloscope.
8. To enable the output:
- a) Press the MOVE button until the arrow pointer is pointing at the output menu item.
 - b) Press the CHANGE button. The output submenu will appear.
 - c) Press MOVE until the arrow pointer is pointing at the “ON” choice.

- d) Press CHANGE to return to the main menu.
9. To change the output amplitude:
- a) Press the MOVE button until the arrow pointer is pointing at the amplitude menu item.
 - b) Press the CHANGE button. The amplitude submenu will appear. Rotate the ADJUST knob until the amplitude is set at +400V.
 - c) Observe the oscilloscope. You should see 1 μ s wide, +400V pulses.
 - d) Rotate the ADJUST knob. The amplitude as seen on the oscilloscope should vary. Set it at +400V.
 - e) Press CHANGE to return to the main menu.
10. Try varying the pulse width, by repeating step (6). As you rotate the ADJUST knob, the pulse width on the oscilloscope will change. It should agree with the displayed value. Stay below 0.5% duty cycle.
11. Reduce the amplitude to +20V, by repeating step (9).
12. To change the output amplitude polarity:
- a) Press the MOVE button until the arrow pointer is pointing at the amplitude menu item.
 - b) Press the CHANGE button. The amplitude submenu will appear.
 - c) Press the "+/-" button. The amplitude as seen on the oscilloscope should become negative.
 - d) Rotate the ADJUST knob. The amplitude as seen on the oscilloscope should vary. Set it at -400V.
13. Press CHANGE to return to the main menu.

This completes the operational check.

PROGRAMMING YOUR PULSE GENERATOR

KEY PROGRAMMING COMMANDS

The “OP1B Interface Programming Manual” describes in detail how to connect the pulse generator to your computer, and the programming commands themselves. A large number of commands are available; however, normally you will only need a few of these. Here is a basic sample sequence of commands that might be sent to the instrument after power-up:

```
*rst                (resets the instrument)
trigger:source internal (selects internal triggering)
frequency 1000 Hz   (sets the frequency to 1000 Hz)
pulse:width 1 us   (sets the pulse width to 1 us)
pulse:delay 1 us   (sets the delay to 1 us)
volt +50           (sets the amplitude to +50 V)
output on          (turns on the output)
```

For triggering a single event, this sequence would be more appropriate:

```
*rst                (resets the instrument)
trigger:source hold (turns off all triggering)
pulse:width 1 us   (sets the pulse width to 1 us)
output on          (turns on the output)
volt:ampl +50      (sets the amplitude to +50 V)
trigger:source immediate (generates a single non-repetitive trigger event)
trigger:source hold (turns off all triggering)
output off         (turns off the output)
```

To set the instrument to trigger from an external TTL signal applied to the rear-panel TRlg connector, use:

```
*rst                (resets the instrument)
trigger:source external (selects external triggering)
pulse:width 1 us   (sets the pulse width to 1 us)
pulse:delay 1 us   (sets the delay to 1 us)
volt:ampl +50      (sets the amplitude to +50 V)
output on          (turns on the output)
```

These commands will satisfy 90% of your programming needs.

ALL PROGRAMMING COMMANDS

For more advanced programmers, a complete list of the available commands is given below. These commands are described in detail in the “OP1B Interface Programming Manual”. (Note: this manual also includes some commands that are not implemented in this instrument. They can be ignored.)

<u>Keyword</u>	<u>Parameter</u>	<u>Notes</u>
LOCAL		
OUTPut:		
:[STATe]	<boolean value>	
:PROTection		
:TRIPped?		[query only]
REMOTE		
[SOURce]:		
:FREQUency		
[:CW FIXed]	<numeric value>	
[SOURce]:		
:PULSe		
:PERiod	<numeric value>	
:WIDTh	<numeric value>	
:DCYCLe	<numeric value>	
:HOLD	WIDTh DCYCLe	
:DELay	<numeric value>	
:GATE		
:TYPE	ASYNc SYNc	
:LEVel	High Low	
[SOURce]:		
:VOLTage		
[:LEVel]		
[:IMMediate]		
[:AMPLitude]	<numeric value>	
:PROTection		
:TRIPped?		[query only]
STATUS:		
:OPERation		
:[EVENT]?		[query only, always returns "0"]
:CONDition?		[query only, always returns "0"]
:ENABle	<numeric value>	[implemented but not useful]
:QUEStionable		
:[EVENT]?		[query only, always returns "0"]
:CONDition?		[query only, always returns "0"]
:ENABle	<numeric value>	[implemented but not useful]
SYSTem:		
:COMMunicate		
:GPIB		
:ADDReSS	<numeric value>	
:SERial		
:CONTRol		
:RTS	ON IBFull RFR	
:[RECeive]		
:BAUD	1200 2400 4800 9600	
:BITS	7 8	

:ECHO	<boolean value>	
:PARity		
: [TYPE]	EVEN ODD NONE	
:SBITS	1 2	
:ERRor		
: [NEXT]?		[query only]
:COUNT?		[query only]
:VERSion?		[query only]
TRIGger:		
:SOURce	INTernal EXTernal MANual HOLD IMMEDIATE	
*CLS		[no query form]
*ESE	<numeric value>	
*ESR?		[query only]
*IDN?		[query only]
*OPC		
*SAV	0 1 2 3	[no query form]
*RCL	0 1 2 3	[no query form]
*RST		[no query form]
*SRE	<numeric value>	
*STB?		[query only]
*TST?		[query only]
*WAI		[no query form]

REPAIR PROCEDURES

In the event of an instrument malfunction, it is most likely that the 2.5 A DC slow blow fuse or the main power fuse on the rear panel has blown. Replace if necessary.

If the unit still does not function, it is most likely that some of the output switching elements (SL19T) may have failed due to an output short circuit condition or to a high duty cycle condition. The switching elements may be accessed by removing the cover plates on the bottom side of the instrument. The cover plate is removed by removing the two 2-56 Phillips screws.

NOTE: First turn off the prime power.

CAUTION: Briefly ground the SL19T tabs to discharge the 400 Volts power supply potential.

The elements may be removed from their sockets using needle-nosed pliers, after removing the four countersunk 2-56 Phillips screws which attach the small copper heat sinks to the body of the instrument. The SL19T is a selected VMOS power transistor in a TO 220 package and may be checked on a curve tracer. If defective, replacement units should be ordered directly from Avtech. When replacing the SL19T switching elements, take care to insure that the short lead (of the three leads) is adjacent to the black dot on the chassis. (See following figure.) The SL19T elements are electrically isolated from the small copper heat sinks but are bonded to the heat sinks using WAKEFIELD TYPE 155 HEAT SINK ADHESIVE.

If the switching elements are not defective, and the instrument is not operating properly, the instrument should be returned to Avtech for repair.

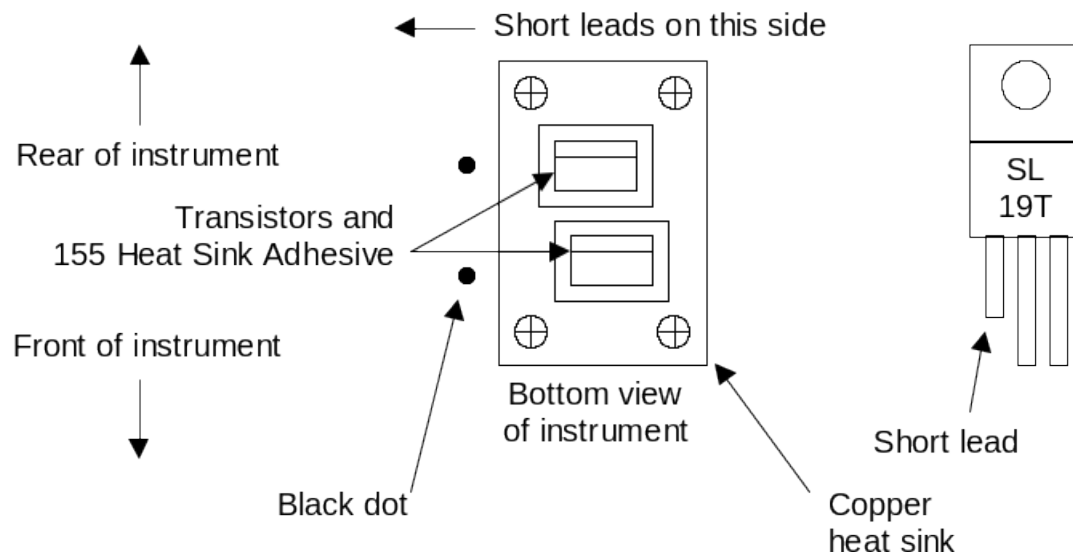

Note that four spare SL19T transistors are provided in the interior of the instrument, screwed to the back-panel of the chassis.

PERFORMANCE CHECK SHEET