



AVTECH ELECTROSYSTEMS LTD.

NANOSECOND WAVEFORM ELECTRONICS
SINCE 1975

P.O. BOX 265
OGDENSBURG, NY
U.S.A. 13669-0265
TEL: (315) 472-5270
FAX: (613) 226-2802

TEL: 1-800-265-6681
FAX: 1-800-561-1970

e-mail: info@avtechpulse.com
<http://www.avtechpulse.com/>

BOX 5120, LCD MERIVALE
OTTAWA, ONTARIO
CANADA K2C 3H4
TEL: (613) 226-5772
FAX: (613) 226-2802

INSTRUCTIONS

MODEL AVR-9D-B-N-MAXA
0 TO -20 VOLTS, 0 TO -10 AMPS
1 MHz PULSE GENERATOR
WITH IEEE 488.2 AND RS-232 CONTROL

SERIAL NUMBER: _____

WARRANTY

Avtech Electrosystems Ltd. warrants products of its manufacture to be free from defects in material and workmanship under conditions of normal use. If, within one year after delivery to the original owner, and after prepaid return by the original owner, this Avtech product is found to be defective, Avtech shall at its option repair or replace said defective item. This warranty does not apply to units which have been disassembled, modified or subjected to conditions exceeding the applicable specifications or ratings. This warranty is the extent of the obligation assumed by Avtech with respect to this product and no other warranty or guarantee is either expressed or implied.

TECHNICAL SUPPORT

Phone: 613-226-5772 or 1-800-265-6681

Fax: 613-226-2802 or 1-800-561-1970

E-mail: info@avtechpulse.com

World Wide Web: <http://www.avtechpulse.com>

TABLE OF CONTENTS

WARRANTY.....	2
TECHNICAL SUPPORT.....	2
TABLE OF CONTENTS.....	3
INTRODUCTION.....	5
SPECIFICATIONS.....	6
ORIGINAL QUOTATION.....	7
EC DECLARATION OF CONFORMITY.....	9
INSTALLATION.....	10
VISUAL CHECK.....	10
POWER RATINGS.....	10
CONNECTION TO THE POWER SUPPLY.....	10
ENVIRONMENTAL CONDITIONS.....	10
LABVIEW DRIVERS.....	11
FUSES.....	12
AC FUSE REPLACEMENT.....	12
DC FUSE REPLACEMENT.....	13
FUSE RATINGS.....	13
FRONT PANEL CONTROLS.....	14
REAR PANEL CONTROLS.....	16
GENERAL INFORMATION.....	18
BASIC PULSE CONTROL.....	18
TRIGGER MODES.....	20
PULSE WIDTH MODES.....	20
GATING MODES.....	20
GENERAL INFORMATION - OPERATING INTO A LOAD.....	21
AMPLITUDE CONTROL.....	21
TEST ARRANGEMENT.....	21
CONNECTING THE LOAD.....	22
CONNECTING TO 1 OHM LOADS USING THE LZ1 OUTPUT LINE.....	22
CONNECTING TO HIGHER IMPEDANCE LOADS.....	23
LENZ'S LAW AND INDUCTIVE VOLTAGE SPIKES.....	23
EXAMPLE PHOTOS.....	24
PROTECTING YOUR INSTRUMENT.....	25

OPERATIONAL CHECK.....	26
MECHANICAL INFORMATION.....	28
TOP COVER REMOVAL.....	28
RACK MOUNTING.....	28
ELECTROMAGNETIC INTERFERENCE.....	28
MAINTENANCE.....	29
REGULAR MAINTENANCE.....	29
CLEANING.....	29
PROGRAMMING YOUR PULSE GENERATOR.....	30
KEY PROGRAMMING COMMANDS.....	30
ALL PROGRAMMING COMMANDS.....	31
REPAIR PROCEDURE.....	33
PERFORMANCE CHECK SHEET.....	0

Manual Reference: /fileserver1/officefiles/instructword/avr-9/AVR-9D-B-N-MAXA,edition1.sxw.
Last modified February 29, 2024.
Copyright © 2024 Avtech Electrosystems Ltd, All Rights Reserved.

INTRODUCTION

The AVR-9D-B-N-MAXA is a high performance, GPIB and RS232-equipped instrument capable of producing amplitudes of up to -20 V, and currents up to -10 Amps, at repetition rates as high as 1 MHz.

This instrument is normally operated into a load consisting of a resistance or a resistance in series with a diode. A high-power low-inductance 1.0 Ohm resistance is required in series with the diode load to limit the output current to 10 Amps or less, and to terminate the output transmission line. The characteristic impedance (Z_0) of the output transmission line is 1 Ohm.

If the load is a purely resistive 1 Ohm load, the maximum permitted output voltage is limited to -10V, due to the -10 Amp maximum current rating. If the load consists of a 1 Ohm resistance in series with a diode whose forward voltage drop is V_F ($\leq 10V$), the maximum permitted output voltage is limited to $-10V - V_F$, up to a limit of -20V.

The pulse width is variable from 100 ns to 1 us, and the maximum duty cycle is 25%.

The rise and fall times (20%-80%) are less than 30 ns, into non-inductive loads. Please note, however, that since inductive time constants are given by $\tau = L/R$, and $R = 1\Omega$ typically, any parasitic inductance will add a time constant of approximately 1 ns/nH. This will degrade the 20%-80% rise and fall times by approximately 1.6 ns/nH. Typical device leads contribute 5-10 nH per inch of length, so lead lengths must be kept as short as possible. See <http://www.avtechpulse.com/appnote/techbrief10/> for more information.

The AVR-9D-B-N-MAXA can be triggered internally, or triggered or gated by an external source. A front-panel pushbutton can also be used to trigger the instrument. The output pulse width can also be set to follow an input trigger pulse.

The AVR-9D-B-N-MAXA features front panel keyboard and adjust knob control of the output pulse parameters along with a four line by 40-character backlit LCD display of the output amplitude, polarity, pulse width, pulse repetition frequency and delay. The instrument includes memory to store up to four complete instrument setups. The operator may use the front panel or the computer interface to store a complete "snapshot" of all key instrument settings, and recall this setup at a later time.

This instrument is intended for use in research and development laboratories.

SPECIFICATIONS

Model:	AVR-9D-B-N-MAXA
Amplitude:	0 to 20V, $R_L \geq 1 \Omega$, 10 Amps maximum
Pulse width ¹ :	0.1 to 1 us
Rise time, fall time (20%-80%):	≤ 30 ns
Duty Cycle (maximum):	25%
Average Output Power, Max:	50W
PRF:	0 to 1 MHz
Output impedance:	$\leq 0.1 \Omega$
Polarity ² :	Positive or negative (specify -P or -N)
GPIO and RS-232 control ³ :	Standard on -B units.
LabView Drivers:	Check www.avtechpulse.com/labview for availability and downloads
Propagation delay:	≤ 150 ns, Ext Trig in to pulse out
Jitter:	± 100 ps $\pm 0.03\%$ of sync delay (Ext trig in to pulse out)
Trigger required (for Ext Trig mode)	Mode A: +5 Volt, 50 ns or wider (TTL) Mode B: +5 Volt, $PW_{IN} = PW_{OUT}$ (TTL)
Sync delay:	Variable 0 to ± 100 us (sync out to pulse out)
Sync output:	+ 3 Volt, 200 ns, will drive 50 Ohm loads
Gate input:	Synchronous or asynchronous, active high or low, switchable. Suppresses triggering when active.
Connectors:	Output: solder pads on end of LZ1 transmission line Other: BNC
Power requirements:	100 - 240 Volts, 50 - 60 Hz
Dimensions (H x W x D):	100 mm x 430 mm x 375 mm (3.9" x 17" x 14.8")
Chassis material:	cast aluminum frame and handles, blue vinyl on aluminum cover plates
Mounting:	Any
Temperature range:	+15°C to +40°C

1. The output pulse width may also be controlled externally by applying a TTL-level trigger of the desired width to a rear-panel BNC connector ($PW_{IN} = PW_{OUT}$ mode).
2. Indicate desired polarity by suffixing model number with -P or -N (i.e. positive or negative).
3. Provides IEEE-488.2 GPIO and RS-232 control of amplitude, pulse width, polarity, PRF and delay.

ORIGINAL QUOTATION

Date: Wed, 14 Apr 2004 13:19:50 -0400
From: Avtech Sales
To: John Gomes
Subject: Re: Pulser for Maxion Technologies Inc.

To: John Gomes
Maxion Technologies
301-394-2874
jgomes@maxion.com

John,

Following your recent inquiry, I am pleased to quote as follows:

Quote number: 12035.01

Model number: AVR-9D-B-P-MAXA

Description: Medium Voltage High Speed Pulser

Amplitude: 0 to +20V. A high-power low-inductance 1.0 Ohm resistance is required in series with your diode load to limit the output current to 10 Amps or less, and to terminate the output transmission line. The characteristic impedance (Z0) of the output transmission line is 1 Ohm.

Pulse width (FWHM): 100 ns to 1 us

Duty cycle: 25% maximum

Average output power: 50 Watts maximum

Rise and fall times (20%-80%): < 30 ns

PRF: 1 MHz maximum

Other: as per the standard AVR-9D-B-P, described at
<http://www.avtechpulse.com/medium/avr-9d/>

Price: \$9998 US each, FOB destination.

Estimated delivery: 60 days after receipt of order.

Quote number: 12035.02

Model number: AVR-9D-B-N-MAXA

Description: Medium Voltage High Speed Pulser

Amplitude: 0 to -20V. A high-power low-inductance 1.0 Ohm resistance is required in series with your diode load to limit the output current to 10 Amps or less, and to terminate the output transmission line. The characteristic impedance (Z0) of the output transmission line is 1 Ohm.

Other: same as the AVR-9D-B-P-MAXA

Due to the high-power nature of these units, we can not provide a dual-polarity model, so I have quoted on -P and -N versions above.

Please note that you would need a high-power low-inductance resistor in series with you diode. The typical power dissipation could be (20V - 6V) x 10A x 25% = 35 Watts. Such a resistor would need to be fan-cooled or even water-cooled.

Please call or email me if I can be of further assistance.

Regards,
Dr. Michael J. Chudobiak
Chief Engineer

--- Avtech Electrosystems Ltd. ----- since 1975 ---

PO Box 265 ph: 1-800-265-6681 or 613-226-5772 Box 5120,
Ogdensburg, fax: 1-800-561-1970 or 613-226-2802 LCD Merivale
New York email: info@avtechpulse.com Ottawa, Ontario
USA 13669-0265 http://www.avtechpulse.com/ Canada K2C 3H4

Nanosecond Waveform Generators
for general purpose, R&D and OEM applications

Pulse Generators - Laser Diode Drivers - Pulse Amplifiers
Impulse Generators - Current Pulsers - Delay Generators - Splitters
Function Generators - Monocycle Generators - Frequency Dividers + more!

John Gomes wrote:

>
>
> Dear Dr. Chudobiak:
>
>
>
> In my previous email, I have said that we already have an AV-1011-B.
> This pulser will give us 100 nsec pulses (minimum), 10% duty cycle
> (max), and up to nearly 2A output current.
>
> As you have asked in your email, I'm giving you our present requirements
> below:
>
>
>
> 1) 8-10 Amps output current, 10-25% duty cycle.
> 2) 100 nsec to 1 usec. This is what we have with the AV-1011-B. We use
> 100 nsec frequently; and 1 usec too.
> 3) RISE TIMES: 20-30 nsec. I am not picky about this. This is the
> maximum rise time that I would be able to use and still have a usable
> 100 nsec pulse.
> 4) PRF: 100 Hz to 1 MHz.
> 5) VOLTAGE REQUIREMENTS: Usually 6-10 Volts dropped across device.
>
> You previously asked "Is your diode forward voltage drop still 10V?" The
> answer is - yes, and note that our lasers are unipolar devices, but
> their I-V characteristics "look" like bipolar diodes. I am aware that
> many research devices have high voltage thresholds due to materials
> issues and/or high contact resistances. The voltage at threshold for
> Cascade lasers is unlikely to change -- the devices are already 97%
> voltage efficient.
>
> Our Quantum Cascade Lasers use negative polarity applied to the top
> contact and thresholds are 6-7 volts. Our Interband Cascade Lasers use
> positive voltage supplied at the top contact and thresholds are also 6-7
> volts (except positive polarity). However, the voltage at threshold will
> scale linearly with the number of cascades designed into the active
> region, and we may very well vary the number of cascades grown into the
> devices in the future -- so we want 10 Volt compliance in anticipation
> of this eventuality. For ICLs, the differential resistance abruptly
> drops by a factor of ~10 at the threshold current. Differential
> resistances are between 2 and 10 Ohms above threshold, varying with
> device size.
>
> A PowerPoint file of the I-V characteristic of a 3.3 um laser is attached.
>
> After looking through your suggestions, it looks like we can't get both
> fast rise times (100 nsec minimum pulse widths) and high (10-25%) duty
> cycles in 8-10 amp output level pulsers. We may need to compromise and
> get one or the other (fast pulses, high duty cycle). But if you have any
> suggestions, I would really appreciate it. Thank you.
>
>
>
> Sincerely,
>
>
> John Gomes
>
> Maxion Technologies Inc.
>
> (301)394-2874
>
> jgomes@maxion.com

EC DECLARATION OF CONFORMITY

We

Avtech Electrosystems Ltd.
P.O. Box 5120, LCD Merivale
Ottawa, Ontario
Canada K2C 3H4

declare that this pulse generator meets the intent of Directive 89/336/EEC for Electromagnetic Compatibility. Compliance pertains to the following specifications as listed in the official Journal of the European Communities:

EN 50081-1 Emission

EN 50082-1 Immunity

and that this pulse generator meets the intent of the Low Voltage Directive 72/23/EEC as amended by 93/68/EEC. Compliance pertains to the following specifications as listed in the official Journal of the European Communities:

EN 61010-1:2001 Safety requirements for electrical equipment for measurement, control, and laboratory use



INSTALLATION

VISUAL CHECK

After unpacking the instrument, examine to ensure that it has not been damaged in shipment. Visually inspect all connectors, knobs, liquid crystal displays (LCDs), and the handles. Confirm that a power cord, a GPIB cable, an LZ1 output cable, an LZ1-to-BNC adapter, and two instrumentation manuals (this manual and the “Programming Manual for -B Instruments”) are with the instrument. If the instrument has been damaged, file a claim immediately with the company that transported the instrument.

POWER RATINGS

This instrument is intended to operate from 100 - 240 V, 50 - 60 Hz.

The maximum power consumption is 150 Watts. Please see the “FUSES” section for information about the appropriate AC and DC fuses.

This instrument is an “Installation Category II” instrument, intended for operation from a normal single-phase supply.

CONNECTION TO THE POWER SUPPLY

An IEC-320 three-pronged recessed male socket is provided on the back panel for AC power connection to the instrument. One end of the detachable power cord that is supplied with the instrument plugs into this socket. The other end of the detachable power cord plugs into the local mains supply. Use only the cable supplied with the instrument. The mains supply must be earthed, and the cable used to connect the instrument to the mains supply must provide an earth connection. (The supplied cable does this.)

ENVIRONMENTAL CONDITIONS

This instrument is intended for use under the following conditions:

- 1) indoor use;
- 2) altitude up to 2 000 m;
- 3) temperature 5 °C to 40 °C;
- 4) maximum relative humidity 80 % for temperatures up to 31 °C decreasing linearly to 50 % relative humidity at 40 °C;
- 5) Mains supply voltage fluctuations up to ± 10 % of the nominal voltage;
- 6) no pollution or only dry, non-conductive pollution.

LABVIEW DRIVERS

A LabVIEW driver for this instrument is available for download on the Avtech web site, at <http://www.avtechpulse.com/labview>. A copy is also available in National Instruments' Instrument Driver Library at <http://www.natinst.com/>.

FUSES

This instrument contains four fuses. All are accessible from the rear-panel. Two protect the AC prime power input, and two protect the internal DC power supplies. The locations of the fuses on the rear panel are shown in the figure below:

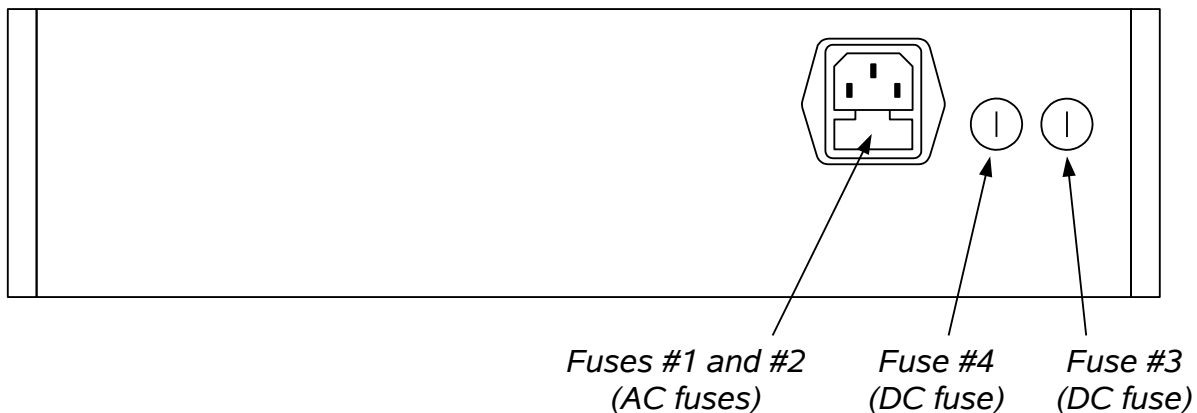

AC FUSE REPLACEMENT

To physically access the AC fuses, the power cord must be detached from the rear panel of the instrument. The fuse drawer may then be extracted using a small flat-head screwdriver, as shown below:

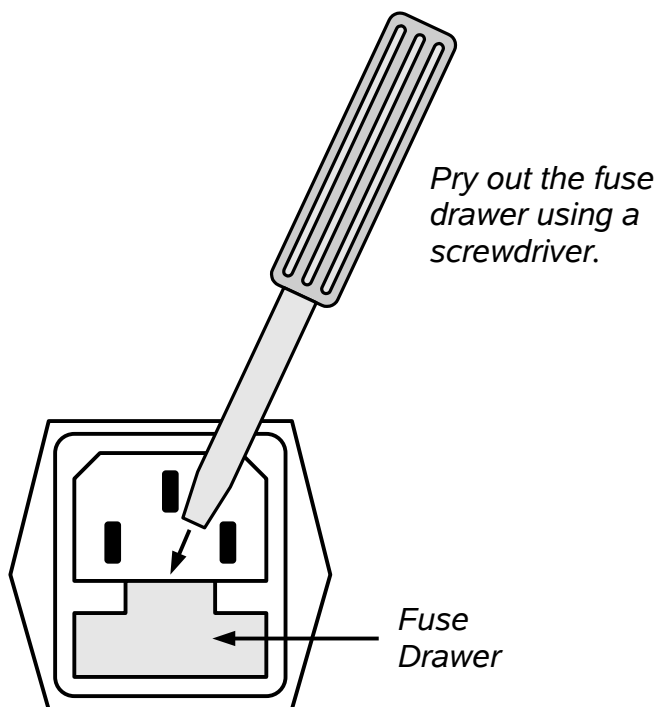

DC FUSE REPLACEMENT

The DC fuses may be replaced by inserting the tip of a flat-head screwdriver into the fuse holder slot, and rotating the slot counter-clockwise. The fuse and its carrier will then pop out.

FUSE RATINGS

The following table lists the required fuses:

Fuses	Nominal Mains Voltage	Rating	Case Size	Manufacturer's Part Number (Wickmann)	Distributor's Part Number (Digi-Key)
#1, #2 (AC)	115 V	1.6A, 250V, Time-Delay	5×20 mm	1951160000	WK5053-ND
	230 V	0.8A, 250V, Time-Delay	5×20 mm	1950800000	WK5046-ND
#3 (DC)	N/A	4.0A, 250V, Time-Delay	5×20 mm	1951400000	WK5062-ND
#4 (DC)	N/A	4.0A, 250V, Time-Delay	5×20 mm	1951400000	WK5062-ND

The fuse manufacturer is Wickmann (<http://www.wickmann.com/>).

Replacement fuses may be easily obtained from Digi-Key (<http://www.digikey.com/>) and other distributors.

FRONT PANEL CONTROLS

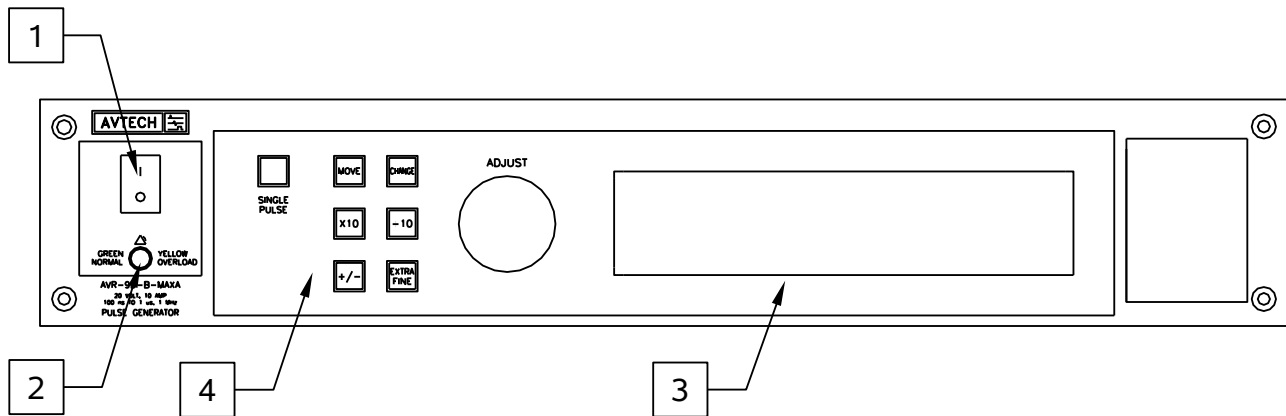

1. POWER Switch. This is the main power switch. When turning the instrument on, there may be a delay of several seconds before the instrument appears to respond.
2. OVERLOAD Indicator. When the instrument is powered, this indicator is normally green, indicating normal operation. If this indicator is yellow, an internal automatic overload protection circuit has been tripped. If the unit is overloaded (by operating at an exceedingly high duty cycle or by operating into a very low impedance), the protective circuit will disable the output of the instrument and turn the indicator light yellow. The light will stay yellow (i.e. output disabled) for about 5 seconds after which the instrument will attempt to re-enable the output (i.e. light green) for about 1 second. If the overload condition persists, the output will be disabled again (i.e. light yellow) for another 5 seconds. If the overload condition has been removed, the instrument will resume normal operation.

This overload indicator may flash yellow briefly at start-up. This is not a cause for concern.

Note that the output stage will safely withstand a short-circuited load condition.

3. LIQUID CRYSTAL DISPLAY (LCD). This LCD is used in conjunction with the keypad to change the instrument settings. Normally, the main menu is displayed, which lists the key adjustable parameters and their current values. The "Programming Manual for -B Instruments" describes the menus and submenus in detail.

4. KEYPAD.

Control Name	Function
MOVE	This moves the arrow pointer on the display.
CHANGE	This is used to enter the submenu, or to select the operating mode, pointed to by the arrow pointer.
×10	If one of the adjustable numeric parameters is displayed, this increases the setting by a factor of ten.
÷10	If one of the adjustable numeric parameters is displayed, this decreases the setting by a factor of ten.
+/-	If one of the adjustable numeric parameters is displayed, and this parameter can be both positive or negative, this changes the sign of the parameter.
EXTRA FINE	This changes the step size of the ADJUST knob. In the extra-fine mode, the step size is twenty times finer than in the normal mode. This button switches between the two step sizes.
ADJUST	This large knob adjusts the value of any displayed numeric adjustable values, such as frequency, pulse width, etc. The adjust step size is set by the "EXTRA FINE" button. When the main menu is displayed, this knob can be used to move the arrow pointer.

REAR PANEL CONTROLS

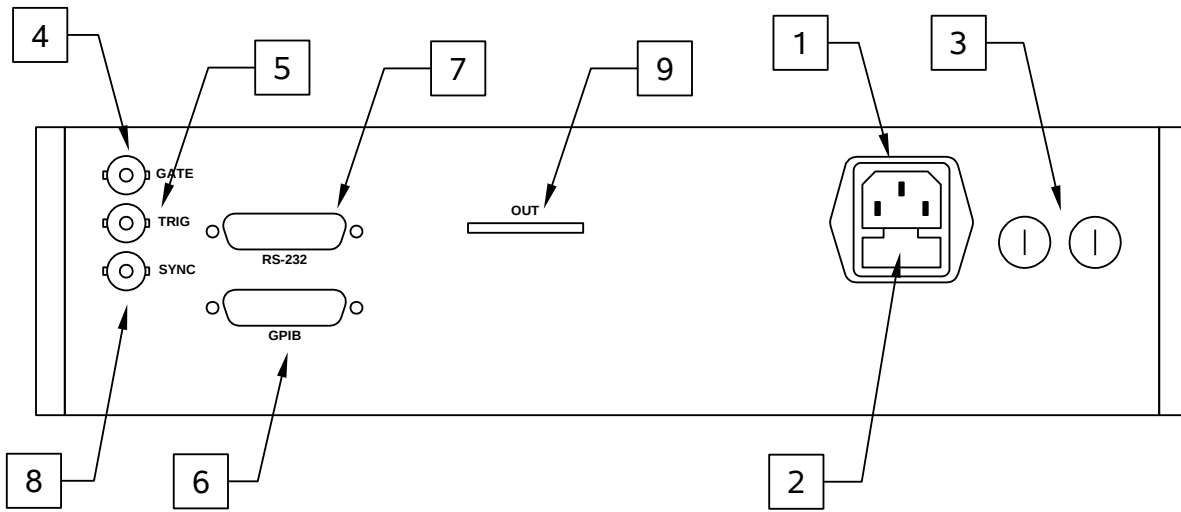

1. AC POWER INPUT. An IEC-320 C14 three-pronged recessed male socket is provided on the back panel for AC power connection to the instrument. One end of the detachable power cord that is supplied with the instrument plugs into this socket.
2. AC FUSE DRAWER. The two fuses that protect the AC input are located in this drawer. Please see the “FUSES” section of this manual for more information.
3. DC FUSES. These two fuses protect the internal DC power supplies. Please see the “FUSES” sections of this manual for more information.
4. GATE. This TTL-level (0 and +5V) logic input can be used to gate the triggering of the instrument. This input can be either active high or active low, depending on the front panel settings or programming commands. (The instrument triggers normally when this input is unconnected). When set to active high mode, this input is pulled-down to ground by a 1 k Ω resistor. When set to active low mode, this input is pulled-up to +5V by a 1 k Ω resistor.
5. TRIG. This TTL-level (0 and +5V) logic input can be used to trigger the instrument, if the instrument is set to triggering externally. The instrument triggers on the rising edge of this input. The input impedance of this input is 1 k Ω . (Depending on the length of cable attached to this input, and the source driving it, it may be desirable to add a coaxial 50 Ohm terminator to this input to provide a proper transmission line termination. The Pasternack (www.pasternack.com) PE6008-50 BNC feed-thru 50 Ohm terminator is suggested for this purpose.)

When triggering externally, the instrument can be set such that the output pulse width tracks the pulse width on this input, or the output pulse width can be set independently.

6. GPIB Connector. A standard GPIB cable can be attached to this connector to allow the instrument to be computer-controlled. See the “Programming Manual for -B Instruments” for more details on GPIB control.
7. RS-232 Connector. A standard serial cable with a 25-pin male connector can be attached to this connector to allow the instrument to be computer-controlled. See the “Programming Manual for -B Instruments” for more details on RS-232 control.
8. SYNC Connector. This connector supplies a SYNC output that can be used to trigger other equipment, particularly oscilloscopes. This signal leads (or lags) the main output by a duration set by the "DELAY" controls and has an approximate amplitude of +3 Volts to $R_L > 1 \text{ k}\Omega$ with a pulse width of approximately 200 ns.
9. OUT Cable. The LZ1 cable that exits the instrument at this point provides the main output signal, into load impedances of 1Ω or higher. This non-removable cable extends 12” beyond the rear panel, where it is terminated by a small section of circuit board, to which the load may be soldered. See the “GENERAL INFORMATION - OPERATING INTO A LOAD” chapter of this manual for more details.

GENERAL INFORMATION

BASIC PULSE CONTROL

This instrument can be triggered by its own internal clock or by an external TTL trigger signal. In either case, two output channels respond to the trigger: OUT and SYNC. The OUT channel is the signal that is applied to the load. Its amplitude and pulse width are variable. The SYNC pulse is a fixed-width TTL-level reference pulse used to trigger oscilloscopes or other measurement systems. When the delay is set to a positive value the SYNC pulse precedes the OUT pulse. When the delay is set to a negative value the SYNC pulse follows the OUT pulse.

These pulses are illustrated below, assuming internal triggering, positive delay, and a positive output amplitude:

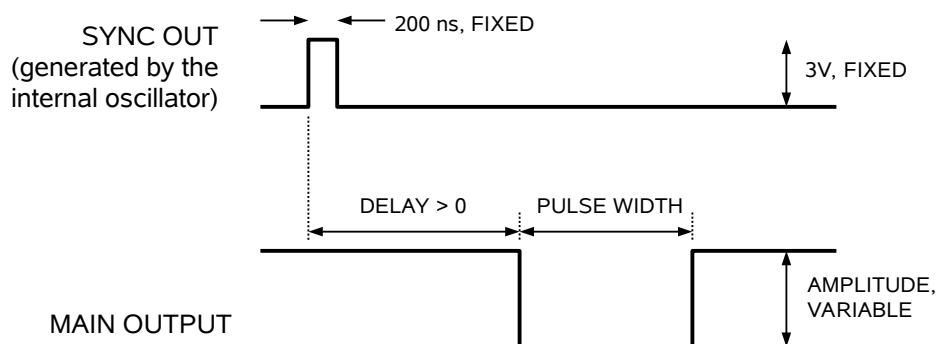

Figure A

If the delay is negative, the order of the SYNC and OUT pulses is reversed:

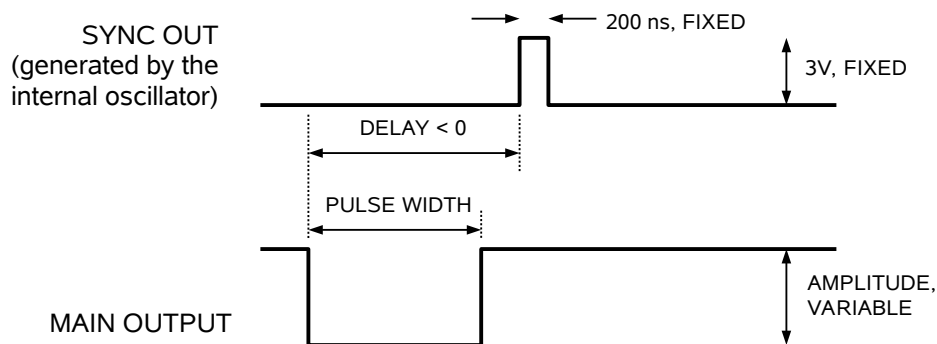

Figure B

The next figure illustrates the relationship between the signals when an external TTL-level trigger is used:

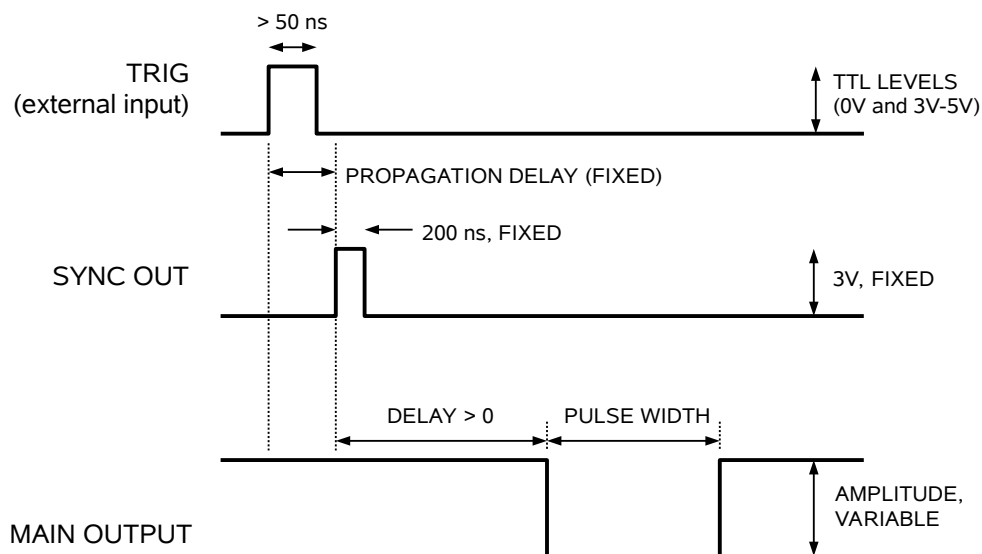

Figure C

As before, if the delay is negative, the order of the SYNC and OUT pulses is reversed.

The last figure illustrates the relationship between the signal when an external TTL-level trigger is used in the $PW_{IN}=PW_{OUT}$ mode. In this case, the output pulse width equals the external trigger's pulse width (approximately), and the delay circuit is bypassed:

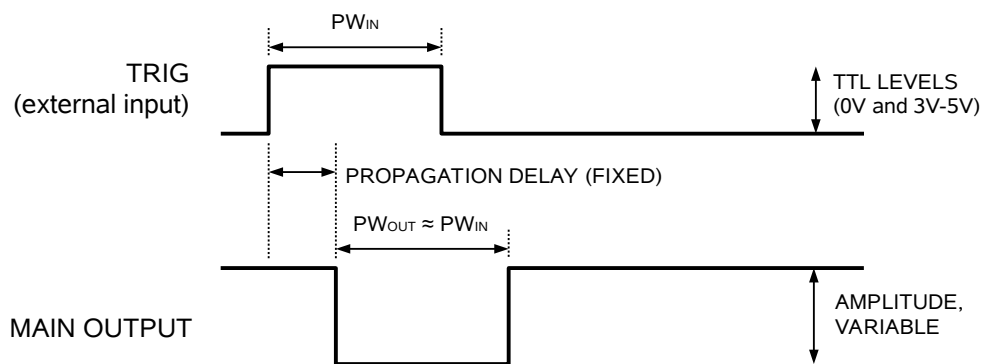

Figure D

The delay, pulse width, and frequency (when in the internal mode), of the OUT pulse can be varied with front panel controls or via the GPIB or RS-232 computer interfaces.

TRIGGER MODES

This instrument has four trigger modes:

- Internal Trigger: the instrument controls the trigger frequency, and generates the clock internally.
- External Trigger: the instrument is triggered by an external TTL-level clock on the back-panel TRIG connector.
- Manual Trigger: the instrument is triggered by the front-panel “SINGLE PULSE” pushbutton.
- Hold Trigger: the instrument is set to not trigger at all.

These modes can be selected using the front panel trigger menu, or by using the appropriate programming commands. (See the “Programming Manual for -B Instruments” for more details.)

PULSE WIDTH MODES

This instrument has two pulse width modes:

- Normal: the instrument controls the output pulse width.
- $PW_{IN}=PW_{OUT}$: the output pulse width equals the pulse width of the trigger signal on the “TRIG” connector. The instrument must be in the external trigger mode.

These modes can be selected using the front panel pulse width menu, or by using the appropriate programming commands. (See the “Programming Manual for -B Instruments” for more details.)

GATING MODES

Triggering can be suppressed by a TTL-level signal on the rear-panel GATE connector. The instrument can be set to stop triggering when this input high or low, using the front-panel gate menu or the appropriate programming commands. This input can also be set to act synchronously or asynchronously. When set to asynchronous mode, the GATE will disable the output immediately. Output pulses may be truncated. When set to synchronous mode, the output will complete the full pulse width if the output is high, and then stop triggering. No pulses are truncated in this mode.

GENERAL INFORMATION - OPERATING INTO A LOAD

AMPLITUDE CONTROL

The AVR-9D-B-N-MAXA pulse generator is a voltage pulser. The current amplitude is determined by Ohm's Law. That is, the current is the output voltage divided by the load resistance. More specifically:

$$I_{OUT} = (V_{SETTING} - V_{DIODE}) / R,$$

where $V_{SETTING}$ is the set amplitude, V_{DIODE} is the diode voltage (if present), and R is the series resistance (including any series resistance in the diode itself). R is normally 1Ω ; it should not be smaller than this. I_{OUT} must not exceed -10 Amps, and $V_{SETTING}$ must not exceed -20V, and R must be 1 Ohm or higher.

TEST ARRANGEMENT

The one possible test arrangement is shown below, assuming that the device under test is a diode:

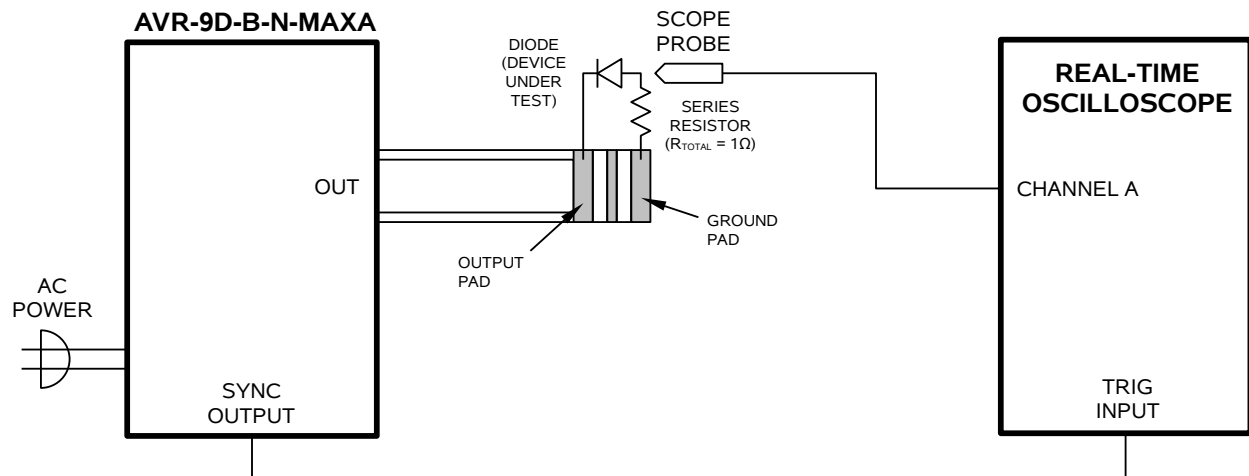

There are several key points to note. As explained above, a resistance must be added in series with the diode load, to limit the maximum current. This resistance may also be used to monitor the current through the diode current. If connected as shown above, the resistor voltage displayed on the oscilloscope is directly proportional to the diode current. It is essential the low-inductance resistors be used. Several non-inductive, medium power resistors should be used in parallel (for instance, five 4.7 Ohm 2W resistors). The Ohmite OY series (www.ohmite.com) or the RCD RSF2B series (www.rcd-comp.com) are appropriate.

However, more accurate current waveforms are typically obtained if a current probe is used. For pulse widths of 500 ns and less, the Integrated Sensor Technologies (<http://www.isensortech.com>) Model 711S current probe is recommended, due to its small size and fast response. For wider pulse widths, the larger Tektronix CT-2 probe may be used. A test set-up using current probes is shown below:

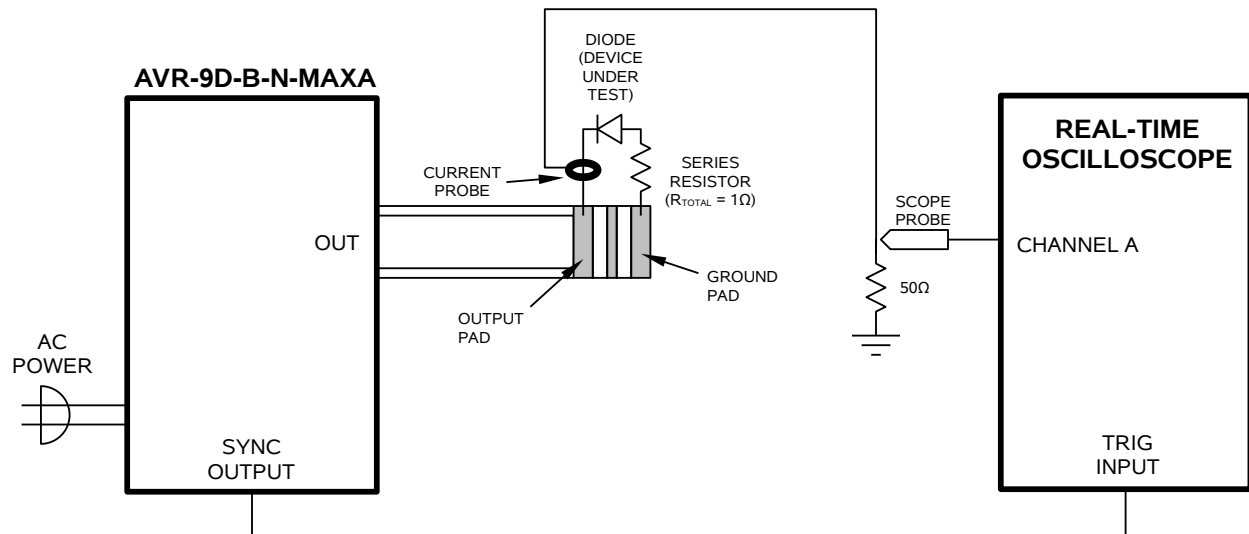

Both the 711S and the CT-2 must be terminated with a 50 Ohm load, as shown above.

CONNECTING THE LOAD

The AVR-9D-B-N-MAXA generates waveforms with relatively fast rise and fall times (< 80 ns) and high current amplitudes (to 20 Amps). Because of this, some care must be taken when connecting the load to the instrument if waveform distortions (ringing, overshoot, degraded rise time) are to be avoided.

CONNECTING TO 1 OHM LOADS USING THE LZ1 OUTPUT LINE

The AVR-9D-B-N-MAXA is optimized for use with 1Ω loads. A flexible, 1Ω-characteristic-impedance transmission line is supplied with this instrument. One end is permanently attached to the rear panel, and the other end is terminated with a 1.0 × 2.5 cm section of glass epoxy circuit board.

The load may be soldered to the circuit board end. The circuit board layout is illustrated below:

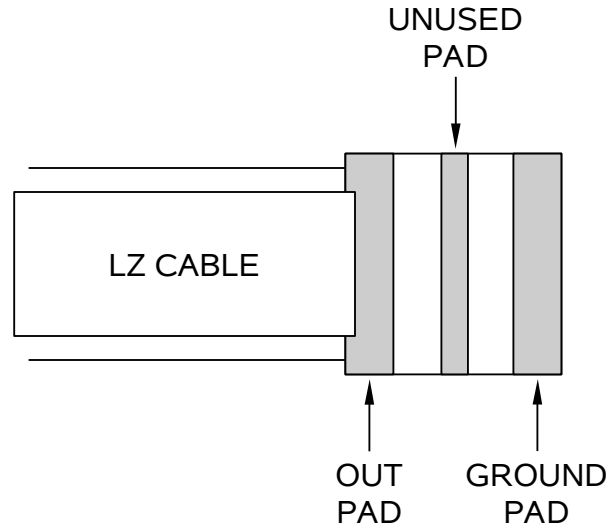

The length of leads used to connect the load to the circuit board should be kept extremely short (< 0.5 cm), as discussed below.

CONNECTING TO HIGHER IMPEDANCE LOADS

As noted above, the AVR-9D-B-N-MAXA is optimized for use with 1Ω loads. The AVR-9D-B-N-MAXA can be used to drive loads with impedance greater than 1Ω, but some waveform distortions (ringing, overshoot, degraded rise time) may be observed. If this causes difficulties, better performance may be obtained by adding a resistor in parallel with the load to reduce the effective load impedance to 1 Ohm.

LENZ'S LAW AND INDUCTIVE VOLTAGE SPIKES

This instrument is designed to pulse resistive and diode loads and will exhibit a large output spike when used to drive a load with significant inductance (as predicted by LENZ'S LAW). For this reason the load should be connected to the output using low inductance leads (as short as possible and as heavy a gauge as possible).

The voltage developed across an inductance L (in Henries), when the current is changing at a rate given by di_{LOAD}/dt (in Amps/sec), is: $V_{SPIKE} = L \times di_{LOAD}/dt$.

The rise and fall times (20%-80%) are less than 30 ns, into non-inductive loads. Please note, however, that since inductive time constants are given by $\tau = L/R$, and $R = 1\Omega$ typically, any parasitic inductance will add a time constant of approximately 1 ns/nH. This will degrade the 20%-80% rise and fall times by approximately 1.6 ns/nH. Typical device leads contribute 5-10 nH per inch of length, so lead lengths must be kept as short as possible (< 0.5 cm). See <http://www.avtechpulse.com/appnote/techbrief10/> for more information.

EXAMPLE PHOTOS

The photo below shows a low-inductance 1 Ohm resistor (Caddock Electronics MP821) in a TO-220 package soldered between the LZ1 output pad and the back-side ground plane. One lead of the resistor has been fed through an Integrated Sensor Technologies (<http://www.isensortech.com>) Model 711S current probe.

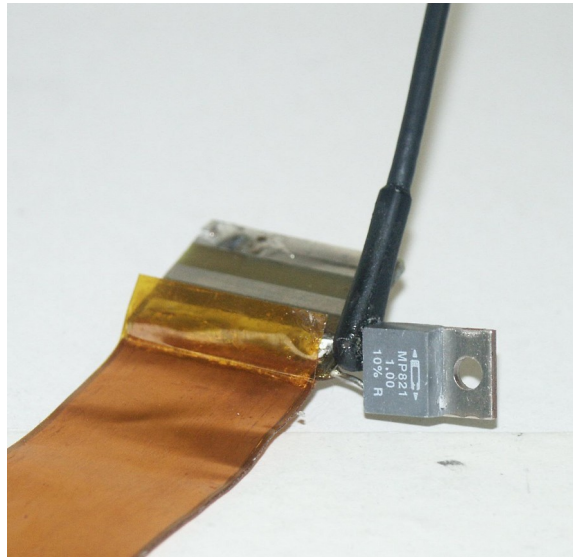

Note how the lead lengths are as short as possible to minimize parasitic inductance. With this arrangement, the following waveforms are obtained:

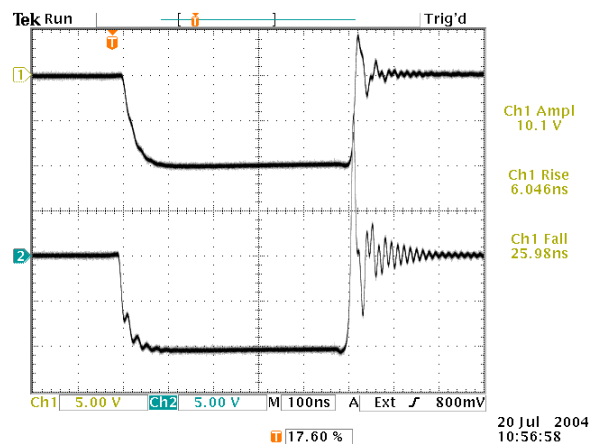

The upper waveform is the output of the current probe (1 V/A). The bottom waveform is the voltage across the resistor, measured with a conventional oscilloscope probe. The voltage waveform shows the voltage spikes caused by the parasitic inductance. The output of the current probe is much “cleaner”.

PROTECTING YOUR INSTRUMENT

Care must be taken to protect your instrument. To obtain maximum performance, the output stage does not have extensive protection circuitry.

The possibility of failure of the output stage is reduced if the following actions are taken whenever possible:

- *Always ensure that the load resistance is a least 1 Ohm.* Operation into short circuits will damage the instrument!
- Keep the duty cycle as low as possible, to reduce the internal power dissipation.
- Keep the pulse repetition frequency as low as possible, to reduce the internal power dissipation.
- Treat the LZ1 output line gently, to avoid physical damage.
- Never apply an externally generated voltage to the output.

OPERATIONAL CHECK

This section describes a sequence to confirm the basic operation of the instrument. It should be performed after receiving the instrument. It is a useful learning exercise as well.

Before proceeding with this procedure, finish reading this instruction manual thoroughly. Then read the “Local Control” section of the “Programming Manual for -B Instruments” thoroughly. The “Local Control” section describes the front panel controls used in this operational check - in particular, the MOVE, CHANGE, and ADJUST controls.

1. Connect a cable from the SYNC OUT connector to the TRIG input of an oscilloscope. Connect a 50W (or higher) 1Ω load to the OUT connector and place the scope probe across this load. (See the “CONNECTING THE LOAD” section for appropriate methods of attaching the load.) Set the oscilloscope to trigger externally with the vertical setting at 5 Volts/div and the horizontal setting at 1 us/div.
2. Turn on the AVR-9D-B-N-MAXA. The main menu will appear on the LCD.
3. To set the AVR-9D-B-N-MAXA to trigger from the internal clock at a PRF of 1 kHz:
 - a) The arrow pointer should be pointing at the frequency menu item. If it is not, press the MOVE button until it is.
 - b) Press the CHANGE button. The frequency submenu will appear. Rotate the ADJUST knob until the frequency is set at 1 kHz.
 - c) The arrow pointer should be pointing at the “Internal” choice. If it is not, press MOVE until it is.
 - d) Press CHANGE to return to the main menu.
4. To set the delay to 1 us:
 - a) Press the MOVE button until the arrow pointer is pointing at the delay menu item.
 - b) Press the CHANGE button. The delay submenu will appear. Rotate the ADJUST knob until the delay is set at 1 us.
 - c) The arrow pointer should be pointing at the “Normal” choice. If it is not, press MOVE until it is.

- d) Press CHANGE to return to the main menu.
5. To set the pulse width to 1 us:
 - a) Press the MOVE button until the arrow pointer is pointing at the pulse width menu item.
 - b) Press the CHANGE button. The pulse width submenu will appear. Rotate the ADJUST knob until the pulse width is set at 1 us.
 - c) The arrow pointer should be pointing at the “Normal” choice. If it is not, press MOVE until it is.
 - d) Press CHANGE to return to the main menu.
 6. At this point, nothing should appear on the oscilloscope.
 7. To enable the output:
 - a) Press the MOVE button until the arrow pointer is pointing at the output menu item.
 - b) Press the CHANGE button. The output submenu will appear.
 - c) Press MOVE until the arrow pointer is pointing at the “ON” choice.
 - d) Press CHANGE to return to the main menu.
 8. To change the output amplitude:
 - a) Press the MOVE button until the arrow pointer is pointing at the amplitude menu item.
 - b) Press the CHANGE button. The amplitude submenu will appear. Rotate the ADJUST knob until the amplitude is set at -10V.
 - c) Observe the oscilloscope. You should see 1 us wide, 20V pulses.
 - d) Rotate the ADJUST knob. The amplitude as seen on the oscilloscope should vary. Set it at -10V.
 - e) Press CHANGE to return to the main menu.
 9. Try varying the pulse width, by repeating step (5). As you rotate the ADJUST knob, the pulse width on the oscilloscope will change. It should agree with the displayed value. Stay below 10% duty cycle.

This completes the operational check.

MECHANICAL INFORMATION

TOP COVER REMOVAL

If necessary, the interior of the instrument may be accessed by removing the four Phillips screws on the top panel. With the four screws removed, the top cover may be slid back (and off).

Always disconnect the power cord before opening the instrument.

There are no user-adjustable internal circuits. For repairs other than fuse replacement, please contact Avtech (info@avtechpulse.com) to arrange for the instrument to be returned to the factory for repair.



Caution: High voltages are present inside the instrument during normal operation. Do not operate the instrument with the cover removed.

RACK MOUNTING

A rack mounting kit is available. The -R5 rack mount kit may be installed after first removing the one Phillips screw on the side panel adjacent to the front handle.

ELECTROMAGNETIC INTERFERENCE

To prevent electromagnetic interference with other equipment, unused coaxial outputs should be terminated with shielded 50Ω coaxial terminators or with shielded coaxial dust caps, to prevent unintentional electromagnetic radiation. All cords and cables should be less than 3m in length.

MAINTENANCE

REGULAR MAINTENANCE

This instrument does not require any regular maintenance.

On occasion, one or more of the four rear-panel fuses may require replacement. All fuses can be accessed from the rear panel. See the “FUSES” section for details.

CLEANING

If desired, the interior of the instrument may be cleaned using compressed air to dislodge any accumulated dust. (See the “TOP COVER REMOVAL” section for instructions on accessing the interior.) No other cleaning is recommended.

PROGRAMMING YOUR PULSE GENERATOR

KEY PROGRAMMING COMMANDS

The “Programming Manual for -B Instruments” describes in detail how to connect the pulse generator to your computer, and the programming commands themselves. A large number of commands are available; however, normally you will only need a few of these. Here is a basic sample sequence of commands that might be sent to the instrument after power-up:

```
*rst                (resets the instrument)
trigger:source internal (selects internal triggering)
frequency 1000 Hz    (sets the frequency to 1000 Hz)
pulse:width 1 us     (sets the pulse width to 1 us)
pulse:delay 1 us     (sets the delay to 1 us)
volt -20             (sets the amplitude to -20 V)
output on            (turns on the output)
```

For triggering a single event, this sequence would be more appropriate:

```
*rst                (resets the instrument)
trigger:source hold  (turns off all triggering)
pulse:width 500 ns   (sets the pulse width to 500 ns)
output on            (turns on the output)
volt:ampl -20        (sets the amplitude to -20 V)
trigger:source immediate (generates a single non-repetitive trigger event)
trigger:source hold  (turns off all triggering)
output off           (turns off the output)
```

To set the instrument to trigger from an external TTL signal applied to the rear-panel TRIG connector, use:

```
*rst                (resets the instrument)
trigger:source external (selects external triggering)
pulse:width 500 ns     (sets the pulse width to 500 ns)
pulse:delay 1 us       (sets the delay to 1 us)
volt:ampl -19V         (sets the amplitude to -19 V)
output on              (turns on the output)
```

These commands will satisfy 90% of your programming needs.

ALL PROGRAMMING COMMANDS

For more advanced programmers, a complete list of the available commands is given below. These commands are described in detail in the “Programming Manual for -B Instruments”. (Note: this manual also includes some commands that are not implemented in this instrument. They can be ignored.)

<u>Keyword</u>	<u>Parameter</u>	<u>Notes</u>
LOCAL		
OUTPut:		
:[STATe]	<boolean value>	
:PROTection		
:TRIPped?		[query only]
REMOTE		
[SOURce]:		
:FREQuency		
[:CW FIXed]	<numeric value>	
[SOURce]:		
:PULSe		
:PERiod	<numeric value>	
:WIDTh	<numeric value> IN	
:DCYClE	<numeric value>	
:HOLD	WIDTh DCYClE	
:DELay	<numeric value>	
:GATE		
:TYPE	ASYNc SYNc	
:LEVel	HIgh LOw	
[SOURce]:		
:VOLTage		
[:LEVel]		
[:IMMEdiate]		
[:AMPLitude]	<numeric value> EXTernal	
:PROTection		
:TRIPped?		[query only]
STATUS:		
:OPERation		
:[EVENT]?		[query only, always returns "0"]
:CONDition?		[query only, always returns "0"]
:ENABle	<numeric value>	[implemented but not useful]
:QUEStionable		
:[EVENT]?		[query only, always returns "0"]
:CONDition?		[query only, always returns "0"]
:ENABle	<numeric value>	[implemented but not useful]
SYSTEM:		
:COMMunicate		
:GPIB		
:ADDReSS	<numeric value>	
:SERial		
:CONTRol		
:RTS	ON IBFull RFR	
:[RECeive]		
:BAUD	1200 2400 4800 9600	
:BITS	7 8	
:ECHO	<boolean value>	
:PARity		

	: [TYPE]	EVEN ODD NONE	
	: SBITS	1 2	
:ERRor			
:[NEXT]?			[query only]
:COUNT?			[query only]
:VERSion?			[query only]
TRIGger:			
:SOURce		INTernal EXTernal MANual HOLD IMMEDIATE	
*CLS			[no query form]
*ESE		<numeric value>	
*ESR?			[query only]
*IDN?			[query only]
*OPC			
*SAV		0 1 2 3	[no query form]
*RCL		0 1 2 3	[no query form]
*RST			[no query form]
*SRE		<numeric value>	
*STB?			[query only]
*TST?			[query only]
*WAI			[no query form]

REPAIR PROCEDURE

In the event of an instrument malfunction, it is most likely that the DC slow-blow fuses or the main AC power fuses on the rear panel have failed. Replace if necessary.

If the unit still does not function, it is most likely that some of the output switching elements (SL34T) may have failed due to an output short circuit condition or to a high duty cycle condition. The switching elements may be accessed by removing the cover plate on the bottom side of the output module. The cover plate is removed by removing the four countersunk 6-32 Phillips screws.

NOTE: First turn off the prime power. Briefly ground the SL34T tabs to discharge the 24V power supply potential.

*Bottom view of instrument,
with cover plate removed.*

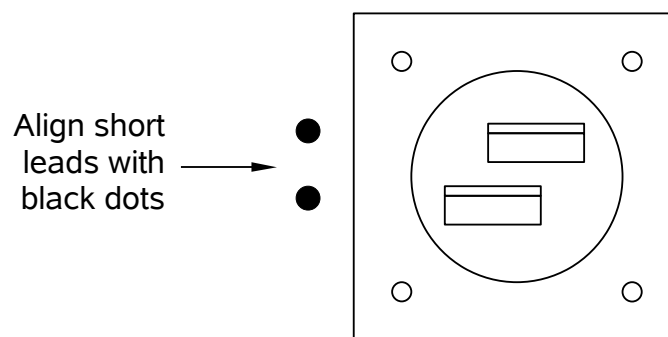

SL34T transistor

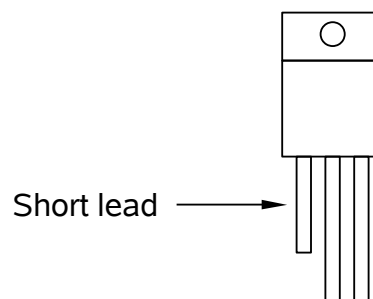

The elements may be removed from their sockets by means of a needle nosed pliers after removing the four counter sunk 2-56 Phillips screws which attach the small copper heat sink to the body of the output module. The SL34T is a selected MOSFET power transistor in a TO-220 package and may be checked on a curve tracer. If defective, replacement units should be ordered directly from Avtech. When replacing the SL34T switching elements, take care to ensure that the short lead (of the three leads) is adjacent to the black dots. (See the above illustration). The SL34T elements are

electrically isolated from the small copper heat sink but are bonded to the heat sink using Wakefield Type 155 Heat Sink Adhesive.

PERFORMANCE CHECK SHEET