

INSTRUCTIONS

MODEL AVR-9D-C-HSB PULSE GENERATOR

S.N.:

WARRANTY

Avtech Electrosystems Ltd. warrants products of its manufacture to be free from defects in material and workmanship under conditions of normal use. If, within one year after delivery to the original owner, and after prepaid return by the original owner, this Avtech product is found to be defective, Avtech shall at its option repair or replace said defective item. This warranty does not apply to units which have been disassembled, modified or subjected to conditions exceeding the applicable specifications or ratings. This warranty is the extent of the obligation assumed by Avtech with respect to this product and no other warranty or guarantee is either expressed or implied.

TECHNICAL SUPPORT

Phone: 613-226-5772 or 1-800-265-6681

Fax: 613-226-2802 or 1-800-561-1970

E-mail: info@avtechpulse.com

World Wide Web: <http://www.avtechpulse.com>

TABLE OF CONTENTS

WARRANTY.....	2
TABLE OF CONTENTS.....	4
FIG. 1: PULSE GENERATOR TEST ARRANGEMENT.....	5
GENERAL OPERATING INSTRUCTIONS.....	6
FIG. 2: FRONT PANEL CONTROLS.....	9
FRONT PANEL CONTROLS.....	10
FIG. 3: BACK PANEL CONTROLS.....	13
BACK PANEL CONTROLS.....	14
TOP COVER REMOVAL AND RACK MOUNTING.....	15
SYSTEM DESCRIPTION AND REPAIR PROCEDURE.....	16
155 16	
SL31T16	
ORIGINAL QUOTATION.....	17
PERFORMANCE CHECK SHEET.....	19

FIG. 1: PULSE GENERATOR TEST ARRANGEMENT

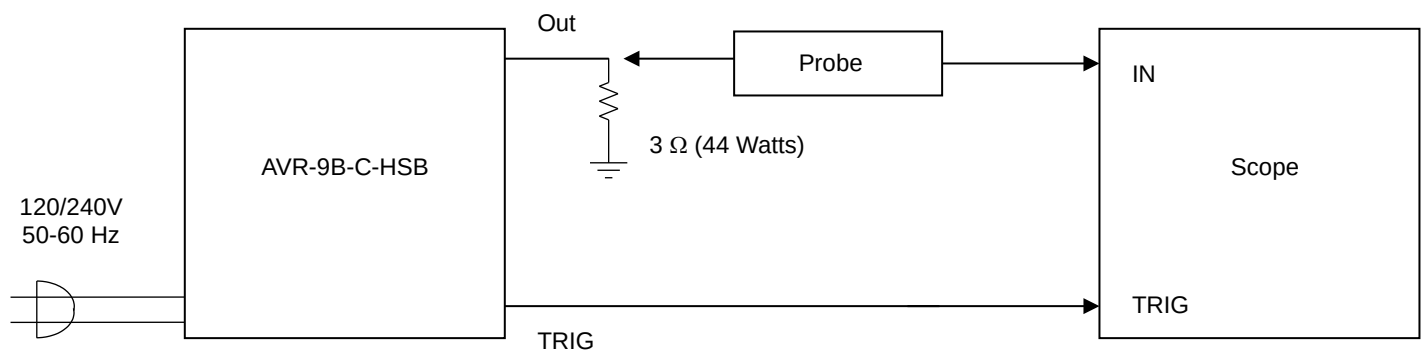

GENERAL OPERATING INSTRUCTIONS

- 1) The special purpose model is designed to drive load impedances as low as 3 Ohms and will source up to 4 Amperes. (With a maximum duty cycle of 90%).
- 2) The bandwidth capability of components and instruments used to display the pulse generator output signal (attenuators, cables, connectors, etc.) should exceed 100 MHz.
- 3) The TRIG output channel provides TTL level signals. The TRIG output precedes the main output when the front panel ADVANCE-DELAY switch is in the ADVANCE position. The TRIG output lags the main output when the switch is in the DELAY position.

The DELAY control controls the relative delay between the reference output pulse provided at the TRIG output and the main output. This delay is variable over the range of 100 us to 100 ms.

	MIN	MAX
Range 1	0.1 ms	1.0 ms
Range 2	1.0 ms	10 ms
Range 3	10 ms	100 ms

- 4) The output pulse width is controlled by means of the front panel ten-turn PW control and by the PW RANGE control. Note that the MODE switch must be in the INT position. The minimum and maximum PW for each range and the corresponding maximum PRF are as follows. Note that the unit may fail if operated at duty cycles exceeding 90%.

	PW min	PW max
Range 1	0.1 ms PRF max 100 Hz	1.0 ms PRF max 100 Hz
Range 2	1.0 ms PRF max 100 Hz	10 ms PRF max 90 Hz
Range 3	10 ms PRF max 90 Hz	100 ms PRF max 9 Hz

- 5) To obtain a stable output display the PRF control on the front panel should be set mid range. The front panel MODE switch should be in the INT position. The DELAY controls and the scope triggering controls are then adjusted to obtain a stable output. The scope may then be used to set the desired PRF by rotating the PRF controls.
- 6) The output pulse amplitude is fixed at +12 Volts.
- 7) An external clock may be used to control the output PRF of the AVR unit by setting the front panel MODE switch in the EXT position and applying a 50 ns (or wider) TTL level pulse to the TRIG BNC connector input. With the MODE switch in the EXT A position, the output pulse width will be controlled by the front panel PW controls. If the switch is in the EXT B position, the output pulse width equals the input trigger pulse width.
- 8) For single pulse manual operation, set the front panel MODE switch in the MAN position and push the SINGLE PULSE button.
- 9) OVERLOAD. An automatic overload protective circuit controls the front panel overload light. If the unit is overloaded (by operating at an exceedingly high duty cycle or by operating into a very low impedance), the protective circuit will turn the output of the instrument OFF and turn the indicator light ON. The light will stay ON (i.e. output OFF) for about 5 seconds after which the instrument will attempt to turn ON (i.e. light OFF) for about 1 second. If the overload condition persists, the instrument will turn OFF again (i.e. light ON) for another 5 seconds. If the overload condition has been removed, the instrument will turn on and resume normal operation. Overload conditions may be removed by:
 - 1) Reducing PRF (i.e. switch to a lower range)
 - 2) Reducing pulse width (i.e. switch to a lower range)
 - 3) Removing output load short circuit (if any)

The overload light may illuminate when the prime power is first applied. The light will extinguish after a few seconds and the unit will then operate normally.

Note that the output stage will safely withstand a short-circuited load condition.

- 10) The unit can be converted from 120 to 240V 50-60 Hz operation by adjusting the voltage selector card in the rear panel fused voltage selector cable connector assembly.

11) For further assistance:

Tel: 613-226-5772
Fax: 613-226-2802
Email: info@avtechpulse.com

FIG. 2: FRONT PANEL CONTROLS

FRONT PANEL CONTROLS

(1) ON-OFF Switch. Applies basic prime power to all stages.

(2) PRF Control. Varies PRF from 1 Hz to 100 Hz as follows:

Range 1	1	Hz	10	Hz
Range 2	10	Hz	100	Hz

(3) DELAY Control. Controls the relative delay between the reference output pulse provided at the TRIG output (4) and the main output (5). This delay is variable over the range of 100 us to about 100 ms. Delay LEADS or LAGS depending on the position of the ADVANCE-DELAY switch.

	MIN	MAX
Range 1	100 us	1.0 ms
Range 2	1.0 ms	10 ms
Range 3	10 ms	100 ms

(4) TRIG Output. This output is used to trigger the scope time base. The output is a TTL level 100 ns (approx.) pulse capable of driving a fifty-Ohm load. This output precedes the output at (5) if the two-position ADVANCE-DELAY switch is in the ADVANCE position. This output follows the output at (5) if the switch is in the DELAY position. The delay range is variable from 0.1 us to 100 us. The external trigger signal is applied at this input when the EXT-INT toggle switch is in the EXT position.

(5) OUT Connector. BNC connector provides output to a 3 Ohm (or higher) load.

- 6) PW Control. A ten-turn control and 3 position range switch which varies the output pulse width from 100 us to 100 ms (when the MODE switch is in the INT position). The minimum and maximum PW for each range and the corresponding maximum PRF are as follows. Note that the unit may fail if operated at duty cycles exceeding the above.

	PW min	PW max
Range 1	0.1 ms PRF max 100 Hz	1.0 ms PRF max 100 Hz
Range 2	1.0 ms PRF max 100 Hz	10 ms PRF max 90 Hz
Range 3	10 ms PRF max 90 Hz	100 ms PRF max 9 Hz

- 7) MODE. With this switch in the INT position, the PRF of the AVR unit is controlled via an internal clock, which in turn is controlled by the PRF control. With the switch in the EXT position, the AVR unit requires a 50 ns (or wider) TTL level pulse applied at the TRIG input in order to trigger the output stages. In addition, in this mode, the scope time base must be triggered by the external trigger source. With the MODE switch in the EXT A position the output pulse width is controlled by the PW controls. With the MODE switch in the EXT B position, the output pulse width equals the input trigger pulse width. For single pulse operation, set the MODE switch in the MAN position.
- 8) SINGLE PULSE. For single pulse manual operation, set the front panel INT-EXT-MAN switch in the MAN position and push the SINGLE PULSE button.
- 9) OVERLOAD. An automatic overload protective circuit controls the front panel overload light. If the unit is overloaded (by operating at an exceedingly high duty cycle or by operating into a very low impedance), the protective circuit will turn the output of the instrument OFF and turn the indicator light ON. The light will stay ON (i.e. output OFF) for about 5 seconds after which the instrument will attempt to turn ON (i.e. light OFF) for about 1 second. If the overload condition persists, the instrument will turn OFF again (i.e. light ON) for another 5 seconds. If the overload condition has been removed, the instrument will turn on and resume normal operation. Overload conditions may be removed by:
- Reducing PRF (i.e. switch to a lower range)
 - Reducing pulse width (i.e. switch to a lower range)
 - Removing output load short circuit (if any)

The overload light may illuminate when the prime power is first applied. The light will extinguish after a few seconds and the unit will then operate normally.

Note that the output stage will safely withstand a short-circuited load condition.

FIG. 3: BACK PANEL CONTROLS

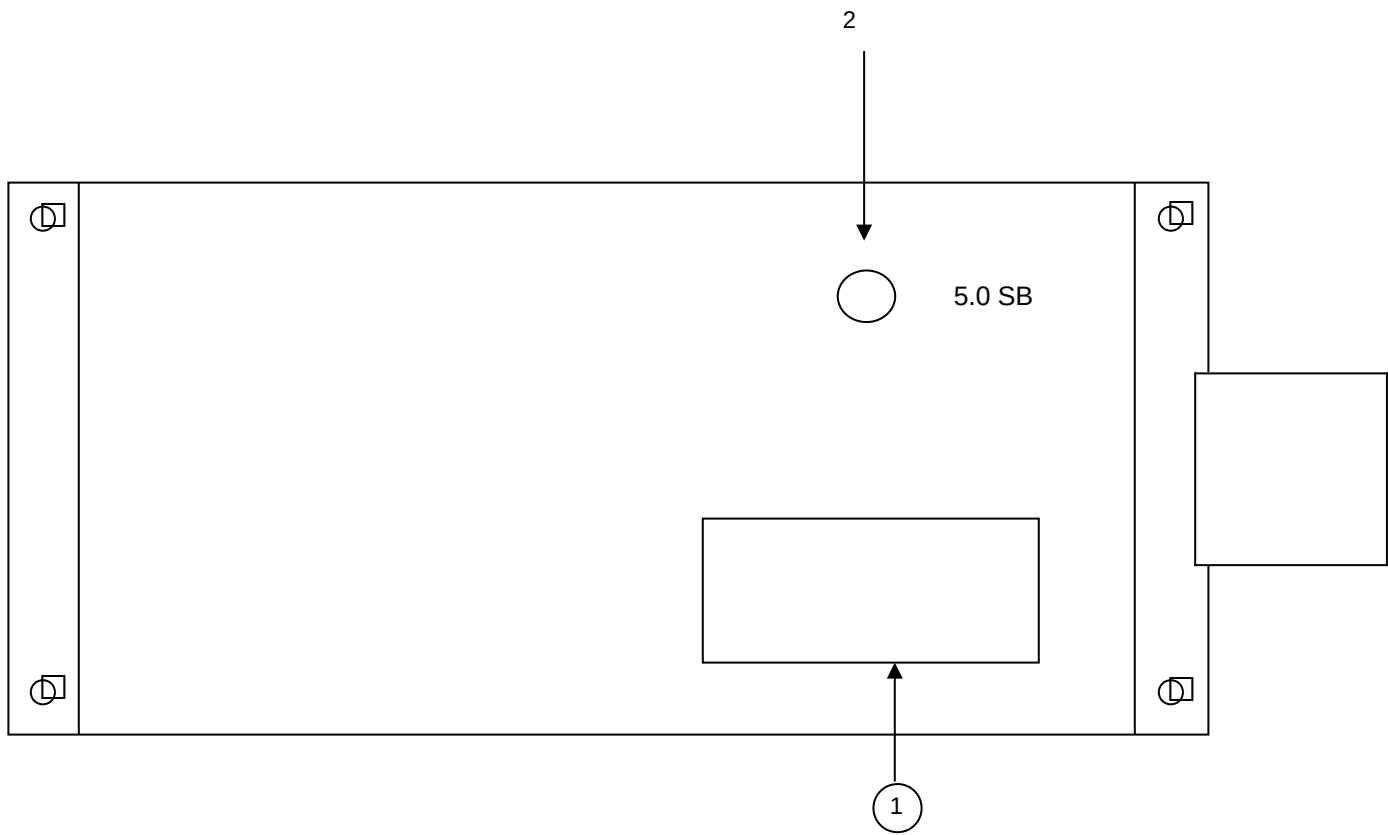

BACK PANEL CONTROLS

- (1) FUSED CONNECTOR, VOLTAGE SELECTOR. The detachable power cord is connected at this point. In addition, the removable cord is adjusted to select the desired input operating voltage. The unit also contains the main power fuse.

For AC line voltages of 110-120V, the power selector card should be installed so that the "120" marking is visible from the rear of the instrument

For AC line voltages of 220-240V, the power selector card should be installed so that the "240" marking is visible from the rear of the instrument.

If it is not set for the proper voltage, remove the fuse and then grasp the card with a pair of pliers and remove it. Rotate horizontally through 180 degrees. Reinstall the card and the correct fuse.

In the 120V setting, a 1.0 A slow blow fuse is required. In the 240V setting, a 0.5A slow blow fuse is required.

- (2) 5.0 SB. This fuse limits the average current supplied to the output stage.

TOP COVER REMOVAL AND RACK MOUNTING

- 1) The interior of the instrument may be accessed by removing the four Phillips screws on the top panel. With the four screws removed, the top cover may be slid back (and off).
- 2) The -R5 rack mount kit may be installed after first removing the one Phillips screw on the side panel adjacent to the front handle.

SYSTEM DESCRIPTION AND REPAIR PROCEDURE

In the event of an instrument malfunction, it is most likely that the power supply 5.0 A slow blow fuse or the main power fuse (1.0 A) on the rear panel has failed. Replace if necessary

If the unit still does not function, it is most likely that some of the output switching elements (SL31T) may have failed due to an output short circuit condition or to a high duty cycle condition. The switching elements may be accessed by removing the cover plate on the bottom side of the output module.

The elements may be removed from their sockets by means of a needle nosed pliers after removing the four counter sunk 2-56 Phillips screws which attach the small copper heat sink to the body of the output module. The SL31T is a selected VMOS power transistor in a TO-220 package and may be checked on a curve tracer. If defective, replacement units should be ordered directly from Avtech. When replacing the SL31T switching elements, take care to ensure that the short lead (of the three leads) is adjacent to the black dots towards the back of the chassis. (See the following illustration). The SL31T elements are electricall isolated from the small copper heat sink but are bonded to the heat sink using Wakefield Type 155 Heat Sink Adhesive.

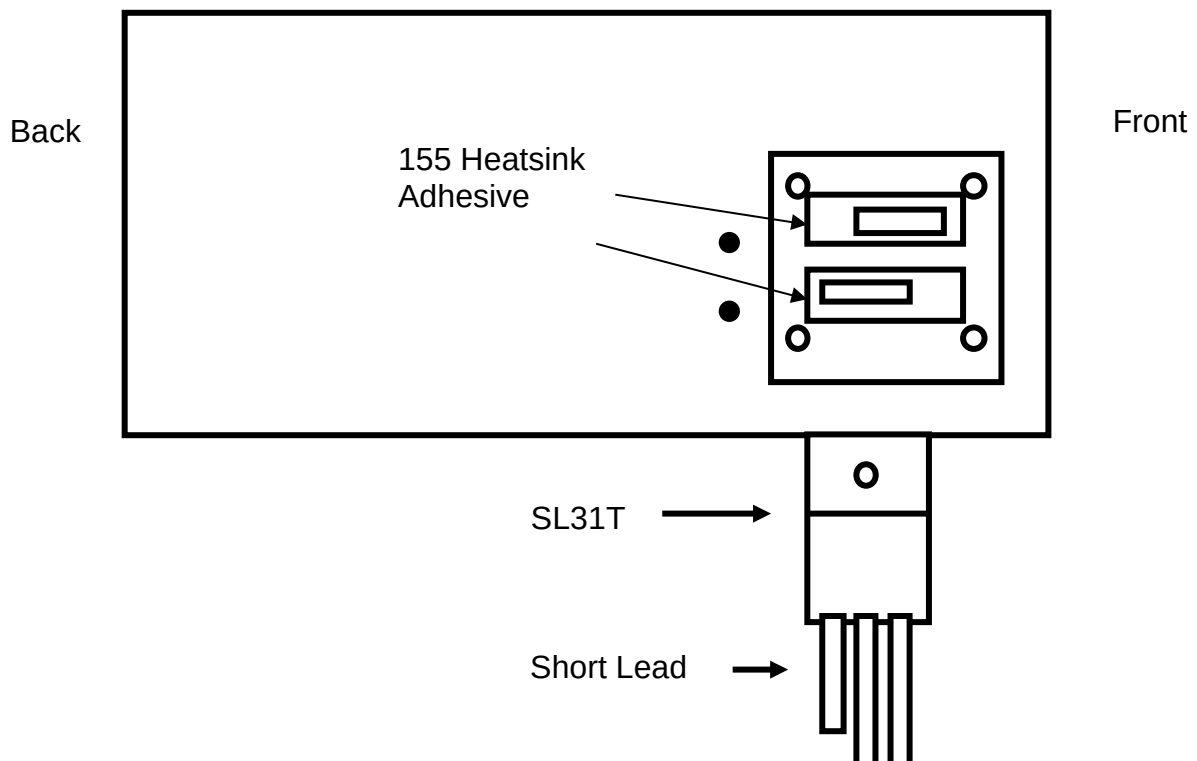

ORIGINAL QUOTATION

Sent: Wednesday, February 27, 2002
To: rohrbae@hydrogensource.com
Cc: Avtech Sales
Subject: Avtech pulse generators

Eric,

I am pleased to quote as follows:

Quote number: 10918A
Model number: AVR-9D-C-HSA
Amplitude: 0 to +12V, variable, to R > 3 Ohms (i.e., 4 Amps max)
Pulse width: 100 us - 100 ms, adjustable
Maximum duty cycle: 90%
PRF: 1 to 100 Hz, adjustable
Max. Average Output Power: 44 Watts
Other: as per the standard AVR-9D-C-P, see
<http://www.avtechpulse.com/speed/avr-9d/>
Price: US \$5960, FOB destination.
Delivery: 60 days after receipt of order

Quote number: 10918B
Model number: AVR-9D-C-HSB
Description: fixed amplitude version of the above
Amplitude: +12V, fixed, to R > 3 Ohms (i.e., 4 Amps max)
Other: as per the AVR-9D-C-HSA
Price: US \$4998, FOB destination.
Delivery: 60 days after receipt of order

Quote number: 10918C
Model number: AVR-9D-B-HSA
Description: as per the AVR-9D-C-HSA, with variable amplitude, but with IEEE-488.2 GPIB and RS-232 interfaces.
Price: US \$8421, FOB destination.
Delivery: 60 days after receipt of order.

Quote number: 10918D
Model number: AVR-9D-B-HSB
Description: as per the AVR-9D-C-HSB, with fixed amplitude, but with IEEE-488.2 GPIB and RS-232 interfaces.
Price: US \$7459, FOB destination.
Delivery: 60 days after receipt of order.

Please call or email me if I can be of further assistance.

Regards,

Dr. Michael J. Chudobiak
VP, New Product Development

--- Avtech Electrosystems Ltd. ----- since 1975 ---

PO Box 265	ph: 1-800-265-6681 or 613-226-5772	PO Box 5120
Ogdensburg, NY	fax: 1-800-561-1970 or 613-226-2802	LCD Merivale
USA 13669-0265	email: info@avtechpulse.com	Ottawa, Ontario
	http://www.avtechpulse.com/	Canada K2C 3H4

Nanosecond Waveform Generators
for general purpose, R&D and OEM applications

Pulse Generators - Laser Diode Drivers - Pulse Amplifiers
Impulse Generators - Delay Generators - Comb Generators - Splitters
Function Generators - Monocycle Generators - Frequency Dividers + more!

PERFORMANCE CHECK SHEET