



AVTECH ELECTROSYSTEMS LTD.

NANOSECOND WAVEFORM ELECTRONICS
SINCE 1975

P.O. BOX 265
OGDENSBURG, NY
U.S.A. 13669-0265

TEL: 888-670-8729 (USA & Canada) or +1-613-686-6675 (Intl)
FAX: 800-561-1970 (USA & Canada) or +1-613-686-6679 (Intl)

info@avtechpulse.com - <http://www.avtechpulse.com/>

BOX 5120, LCD MERIVALE
OTTAWA, ONTARIO
CANADA K2C 3H5

INSTRUCTIONS

MODEL AVR-CC2-B

MIL-STD-750-4

METHOD 4031.5 CONDITION C

REVERSE RECOVERY TIME TESTER

SERIAL NUMBER: _____

WARRANTY

Avtech Electrosystems Ltd. warrants products of its manufacture to be free from defects in material and workmanship under conditions of normal use. If, within one year after delivery to the original owner, and after prepaid return by the original owner, this Avtech product is found to be defective, Avtech shall at its option repair or replace said defective item. This warranty does not apply to units which have been disassembled, modified or subjected to conditions exceeding the applicable specifications or ratings. This warranty is the extent of the obligation assumed by Avtech with respect to this product and no other warranty or guarantee is either expressed or implied.

TECHNICAL SUPPORT

Phone: 888-670-8729 (USA & Canada) or +1-613-686-6675 (International)

Fax: 800-561-1970 (USA & Canada) or +1-613-686-6679 (International)

E-mail: info@avtechpulse.com

World Wide Web: <http://www.avtechpulse.com>

TABLE OF CONTENTS

WARRANTY.....2

TECHNICAL SUPPORT.....2

TABLE OF CONTENTS.....3

INTRODUCTION.....5

SPECIFICATIONS.....7

CUSTOMIZATIONS.....8

 AVR-CC2-B-MSB.....8

REGULATORY NOTES.....9

 FCC PART 18.....9

 EC DECLARATION OF CONFORMITY.....9

 DIRECTIVE 2002/95/EC (RoHS).....10

 DIRECTIVE 2002/96/EC (WEEE).....10

 AC POWER SUPPLY REGULATORY NOTES.....11

 FIRMWARE LICENSING.....11

INSTALLATION.....12

 VISUAL CHECK.....12

 POWER RATINGS.....12

 CONNECTION TO THE POWER SUPPLY.....12

 PROTECTION FROM ELECTRIC SHOCK.....13

 ENVIRONMENTAL CONDITIONS.....14

FUSES.....15

 AC FUSE REPLACEMENT.....15

 DC FUSE REPLACEMENT.....16

 FUSE RATINGS.....16

FRONT PANEL CONTROLS.....17

REAR PANEL CONTROLS.....19

TIMING CONTROL.....21

 BASIC TIMING CONTROL.....21

 TRIGGER MODES.....22

 GATING MODES.....23

BASIC TEST ARRANGEMENT.....24

 SAFETY INTERLOCK.....25

MEASUREMENT THEORY.....	26
TEST JIG MECHANICAL ASPECTS.....	28
TEST JIG CONNECTORS.....	29
SPECIFIC TEST JIGS AND TYPICAL RESULTS.....	30
AVX-CC2-DO5-MS1.....	30
AVX-CC2-DO5-MS2.....	32
TROUBLESHOOTING.....	34
PROGRAMMING YOUR PULSE GENERATOR.....	35
KEY PROGRAMMING COMMANDS.....	35
ALL PROGRAMMING COMMANDS.....	36
MECHANICAL INFORMATION.....	38
TOP COVER REMOVAL.....	38
RACK MOUNTING.....	38
ELECTROMAGNETIC INTERFERENCE.....	38
MAINTENANCE.....	39
REGULAR MAINTENANCE.....	39
CLEANING.....	39
TRIGGER DAMAGE.....	39
WIRING DIAGRAMS.....	40
WIRING OF AC POWER.....	40
PCB 158P - LOW VOLTAGE POWER SUPPLY, 1/3.....	41
PCB 158P - LOW VOLTAGE POWER SUPPLY, 2/3.....	42
PCB 158P - LOW VOLTAGE POWER SUPPLY, 3/3.....	43
PCB 235A - HIGH VOLTAGE DC POWER SUPPLY.....	44
PCB 104E - KEYPAD / DISPLAY BOARD, 1/3.....	45
PCB 104E - KEYPAD / DISPLAY BOARD, 2/3.....	46
PCB 104E - KEYPAD / DISPLAY BOARD, 3/3.....	47
PCB 201B - INTERLOCK.....	48
MAIN WIRING.....	49
TEST JIG WIRING (AVX-CC2-DO5-MS1, AVX-CC2-DO5-MS2).....	50
PERFORMANCE CHECK SHEET.....	51

INTRODUCTION

The AVR-CC2-B is a high performance, GPIB and RS232-equipped instrument intended for MIL-STD-750-4 Method 4031.5 Condition C reverse recovery time tests of diodes and other semiconductor devices.

An instrument mainframe provides the high-voltage power and timing control signals to a test jig. The basic equivalent circuit of the jig is illustrated below:

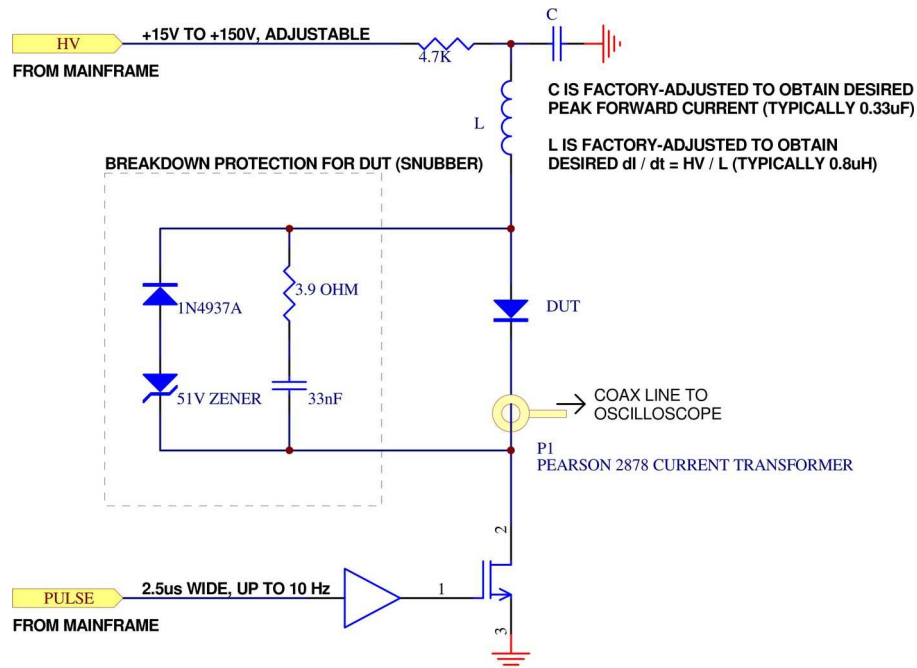

This approach uses a DC-biased MOSFET (with intrinsic body diode) as the switching element, rather than the AC-biased SCR approach shown in MIL-STD-750-4 Figure 4031-6. This is not expected to affect the results in any significant way.

The maximum allowed forward current through DUT (D1) and/or MOSFET (Q1) is +80A, and the maximum reverse current is -40A.

The output of a Pearson 2878 current transformer is provided. This waveform provides a voltage that is proportional to the current through the DUT (D1). The user must observe this waveform on a user-supplied calibrated oscilloscope, and extract the desired measurements from the waveform. The AVR-CC2-B-MSB itself does not report any measurements, and it should not be relied upon for any particular degree of accuracy. The DUT dynamics and parasitics can influence the amplitude and ramp rate. For calibrated results, rely on calibrated oscilloscope measurements and adjust the pulser settings (and possibly L and C) as needed to obtain the desired values.

One or more test jigs are supplied with the instrument, depending on the customizations requested by the user at the time of ordering. Each jig implements

different values of L and C, to achieve specific forward peak currents and di/dt ramp rates for particular diodes. (L and C can be desoldered and changed by the user for calibration adjustment purposes, but is not otherwise recommended.) The value of L will include a certain amount of parasitic inductance in the jig. The governing equations are:

$$I_{FM} \approx HV / \sqrt{L/C}$$

$$di/dt \approx HV / L$$

An R/C snubber and a Zener diode / TVS clamp circuit are provided on each jig to avoid unnecessarily high reverse voltages that may damage the DUT, and to reduce magnitude and duration of trailing oscillations. The user should verify that the test does not generate voltages across the DUT that exceed the DUT breakdown limit.

The user may change the L, C, and snubber values on the jigs to meet different test requirements.

The instrument mainframe is connected to the test jig using a DB-9 control cable and two coaxial cables (one for the trigger signal, and one for the high voltage power).

The AVR-CC2-B includes an internal trigger source, but it can also be triggered or gated by an external source. A front-panel pushbutton can also be used to trigger the instrument.

The AVR-CC2-B features front panel keyboard and adjust knob control of the output pulse parameters along with a four line by 40-character backlit LCD display of the output amplitude, pulse repetition frequency, and delay. The instrument includes memory to store up to four complete instrument setups. The operator may use the front panel or the computer interface to store a complete "snapshot" of all key instrument settings, and recall this setup at a later time.

This instrument is intended for use in research, development, test and calibration laboratories by qualified personnel.

SPECIFICATIONS

Model:	AVR-CC2-B
Intended application:	Reverse recovery time tests, as per MIL-STD-750-4 Method 4031.5 Condition C
Basic waveform:	MOSFET-switched LC impulse
High-voltage bias (HV):	+15V to +150V, adjustable
MOSFET switch on time:	2.5 us, approximately. Not adjustable.
Pulse repetition frequency:	1 to 10 Hz, adjustable
Maximum allowed forward current through DUT (D1) and/or MOSFET (Q1):	+80A
Maximum allowed reverse current through DUT (D1) and/or MOSFET (Q1):	-40A
Output waveform:	The output of a Pearson 2878 current transformer is provided. This waveform provides a voltage that is proportional to the current through the DUT (D1). The user must observe this waveform on a user-supplied calibrated oscilloscope, and extract the desired measurements from the waveform. The AVR-CC2-B-MSB itself does not report any measurements.
Calibration:	Not calibrated. The DUT dynamics and parasitics can influence the amplitude and ramp rate. For calibrated results, rely on calibrated oscilloscope measurements and adjust the pulser settings (and possibly L and C) as needed to obtain the desired values.
Supplied test jig(s), and values of L and C:	Customer-specific.
Mainframe to jig cables:	Control: DB9 male/male, 2m, straight-through. Pulse: SMA-to-SMA coaxial cable, 2m. HV: BNC-to-BNC coaxial cable, 2m.
Mainframe connectors:	TRIG, SYNC, GATE: BNC female
Jig output connector:	SMA female.
Output waveform:	When the output is terminated with the provided 50 Ohm terminator, the output voltage is proportional to the DUT current: $V_{OUT} = I_{DUT} \times 50 \text{ mV / Amp,}$ The output is generated internally by a Pearson 2878 current transformer (bandwidth 30 Hz to 70 MHz).
GPIB and RS-232 control:	Standard on -B units. See http://www.avtechpulse.com/gpib for details.
LabView driver:	Check http://www.avtechpulse.com/labview for availability and downloads
Trigger required:	Ext trig mode: + 5 Volts, 10 ns or wider (TTL)
Gate input:	Active high or low, switchable. Suppresses triggering when active.
Power requirements:	100 - 240 Volts, 50 - 60 Hz
Dimensions:	H x W x D: 100 mm x 430 mm x 375 mm (3.9" x 17" x 14.8")
Chassis material:	Cast aluminum frame and handles, blue vinyl on aluminum cover plates
Temperature range:	+5°C to +40°C

CUSTOMIZATIONS

AVR-CC2-B-MSB

Two test jigs are supplied with the AVR-CC2-B-MSB:

AVX-CC2-DO5-MS1: This jig accepts Microsemi 1N6306 diodes. The values of L (nominally 846 nH) and C (nominally 0.34 μ F) are selected to provide $I_{FM} \approx +70A$ and $di/dt \approx 130 A/\mu s$ when HV = +110V.

AVX-CC2-DO5-MS2: This jig accepts Microsemi diodes labeled "MSC 1231 D8051GM". The values of L (nominally 500 nH) and C (nominally 0.066 μ F) are selected to provide $I_{FM} \approx +40A$ and $di/dt \approx 220 A/\mu s$ when HV = +110V.

REGULATORY NOTES

FCC PART 18

This device complies with part 18 of the FCC rules for non-consumer industrial, scientific and medical (ISM) equipment.

This instrument is enclosed in a rugged metal chassis and uses a filtered power entry module (where applicable). The main output signal is provided on a shielded connector that is intended to be used with shielded coaxial cabling and a shielded load. Under these conditions, the interference potential of this instrument is low.

If interference is observed, check that appropriate well-shielded cabling is used on the output connectors. Contact Avtech (info@avtechpulse.com) for advice if you are unsure of the most appropriate cabling. Also, check that your load is adequately shielded. It may be necessary to enclose the load in a metal enclosure.

If any of the connectors on the instrument are unused, they should be covered with shielded metal "dust caps" to reduce the interference potential.

This instrument does not normally require regular maintenance to minimize interference potential. However, if loose hardware or connectors are noted, they should be tightened. Contact Avtech (info@avtechpulse.com) if you require assistance.

EC DECLARATION OF CONFORMITY



We Avtech Electrosystems Ltd.
 P.O. Box 5120, LCD Merivale
 Ottawa, Ontario
 Canada K2C 3H4

declare that this pulse generator meets the intent of Directive 2004/108/EG for Electromagnetic Compatibility. Compliance pertains to the following specifications as listed in the official Journal of the European Communities:

EN 50081-1 Emission

EN 50082-1 Immunity

and that this pulse generator meets the intent of the Low Voltage Directive 72/23/EEC as amended by 93/68/EEC. Compliance pertains to the following specifications as listed in the official Journal of the European Communities:

EN 61010-1:2001 Safety requirements for electrical equipment for measurement, control, and laboratory use

DIRECTIVE 2002/95/EC (RoHS)

This instrument is exempt from Directive 2002/95/EC of the European Parliament and of the Council of 27 January 2003 on the Restriction of the use of certain Hazardous Substances (RoHS) in electrical and electronic equipment. Specifically, Avtech instruments are considered "Monitoring and control instruments" (Category 9) as defined in Annex 1A of Directive 2002/96/EC. The Directive 2002/95/EC only applies to Directive 2002/96/EC categories 1-7 and 10, as stated in the "Article 2 - Scope" section of Directive 2002/95/EC.

DIRECTIVE 2002/96/EC (WEEE)

European customers who have purchased this equipment directly from Avtech will have completed a "WEEE Responsibility Agreement" form, accepting responsibility for WEEE compliance (as mandated in Directive 2002/96/EC of the European Union and local laws) on behalf of the customer, as provided for under Article 9 of Directive 2002/96/EC.

Customers who have purchased Avtech equipment through local representatives should consult with the representative to determine who has responsibility for WEEE compliance. Normally, such responsibilities will lie with the representative, unless other arrangements (under Article 9) have been made.

Requirements for WEEE compliance may include registration of products with local governments, reporting of recycling activities to local governments, and financing of recycling activities.



AC POWER SUPPLY REGULATORY NOTES

This instrument converts the AC input power to the +24V DC voltage that powers the internal circuitry of this instrument using a Tamura AAD130SD-60-A switching power supply. According to the manufacturer, the Tamura AAD130SD-60-A has the following certifications:

UL60950-1
IEC60950 -1
CSA C22.2 No. 60950- 1
EN60950 -1

and is compliant with:

EN61000-3-2
EN61000-4-2 Level 2
EN61000-4-2 Level 3 (Air Only)
EN61000-4-4 Level 3
EN61000-4-5 Level 3
EN61000-4-11
CISPR 11 and 22 FCC Part 15 Class B (conducted)

FIRMWARE LICENSING

Instruments with firmware versions 5.00 or higher use open-source software internally. Some of this software requires that the source code be made available to the user as a condition of its licensing. This source code is distributed on the device itself. To access it, log in as user “source” with password “source”. The source files are provided in this user's home directory, and are accessible using standard viewing and file transfer tools (such as vim, sz, and scp).

Earlier firmware versions do not contain any open source software.

INSTALLATION

VISUAL CHECK

After unpacking the instrument, examine to ensure that it has not been damaged in shipment. Visually inspect all connectors, knobs, liquid crystal displays (LCDs), and the handles. If the instrument has been damaged, file a claim immediately with the company that transported the instrument.

The following items should be with the instrument:

- 1) One AVR-CC2-B mainframe
- 2) One 2m DB9 control cable
- 3) One 2m BNC-to-BNC coaxial cable
- 4) One 2m SMA-to-SMA coaxial cable
- 5) One 60cm BNC-to-SMA coaxial cable
- 6) One BNC feed-through terminator
- 7) One standard GPIB cable, 2m length
- 8) One AC Power Cord
- 9) One Programming Manual for "-B" Instruments
- 10) One AVR-CC2-B Instruction Manual
- 11) One or more AVX-CC2 test jigs, depending on the ordered customizations.

POWER RATINGS

This instrument is intended to operate from 100 - 240 V, 50 - 60 Hz.

The maximum power consumption is 57 Watts. Please see the "FUSES" section for information about the appropriate AC and DC fuses.

This instrument is an "Installation Category II" instrument, intended for operation from a normal single-phase supply.

CONNECTION TO THE POWER SUPPLY

An IEC-320 three-pronged recessed male socket is provided on the back panel for AC power connection to the instrument. One end of the detachable power cord that is supplied with the instrument plugs into this socket. The other end of the detachable power cord plugs into the local mains supply. Use only the cable supplied with the instrument. The mains supply must be earthed, and the cord used to connect the instrument to the mains supply must provide an earth connection. (The supplied cord does this.)

 Warning: Failure to use a grounded outlet may result in injury or death due to electric shock. This product uses a power cord with a ground connection. It must be

connected to a properly grounded outlet. The instrument chassis is connected to the ground wire in the power cord.

The table below describes the power cord that is normally supplied with this instrument, depending on the destination region:

Destination Region	Description	Option	Manufacturer	Part Number
United Kingdom, Hong Kong, Singapore, Malaysia	BS 1363, 230V, 50 Hz	-AC00	Qualtek	370001-E01
Australia, New Zealand	AS 3112:2000, 230-240V, 50 Hz	-AC01	Qualtek	374003-A01
Continental Europe, Korea, Indonesia, Russia	European CEE 7/7 "Schuko" 230V, 50 Hz	-AC02	Qualtek	364002-D01
North America, Taiwan	NEMA 5-15, 120V, 60 Hz	-AC03	Qualtek	312007-01
Switzerland	SEV 1011, 230V, 50 Hz	-AC06	Qualtek	378001-E01
South Africa, India	SABS 164-1, 220-250V, 50 Hz	-AC17	Volex	2131H 10 C3
Japan	JIS 8303, 100V, 50-60 Hz	-AC18	Qualtek	397002-01
Israel	SI 32, 220V, 50 Hz	-AC19	Qualtek	398001-01
China	GB 1002-1, 220V, 50 Hz	-AC22	Volex	2137H 10 C3

PROTECTION FROM ELECTRIC SHOCK

 Operators of this instrument must be protected from electric shock at all times. The owner must ensure that operators are prevented access and/or are insulated from every connection point. In some cases, connections must be exposed to potential human contact. Operators must be trained to protect themselves from the risk of electric shock. This instrument is intended for use by qualified personnel who recognize shock hazards and are familiar with safety precautions required to avoid possibly injury. In particular, operators should:

1. Keep exposed high-voltage wiring to an absolute minimum.
2. Wherever possible, use shielded connectors and cabling.
3. Connect and disconnect loads and cables only when the instrument is turned off.

4. Keep in mind that all cables, connectors, oscilloscope probes, and loads must have an appropriate voltage rating.
5. Do not attempt any repairs on the instrument, beyond the fuse replacement procedures described in this manual. Contact Avtech technical support (see page 2 for contact information) if the instrument requires servicing. Service is to be performed solely by qualified service personnel.

ENVIRONMENTAL CONDITIONS

This instrument is intended for use under the following conditions:

1. indoor use;
2. altitude up to 2 000 m;
3. temperature 5 °C to 40 °C;
4. maximum relative humidity 80 % for temperatures up to 31 °C decreasing linearly to 50 % relative humidity at 40 °C;
5. Mains supply voltage fluctuations up to ± 10 % of the nominal voltage;
6. no pollution or only dry, non-conductive pollution.

FUSES

This instrument contains four fuses. All are accessible from the rear-panel. Two protect the AC prime power input, and two protect the internal DC power supplies. The locations of the fuses on the rear panel are shown in the figure below:



AC FUSE REPLACEMENT

To physically access the AC fuses, the power cord must be detached from the rear panel of the instrument. The fuse drawer may then be extracted using a small flat-head screwdriver, as shown below:



DC FUSE REPLACEMENT

The DC fuses may be replaced by inserting the tip of a flat-head screwdriver into the fuse holder slot, and rotating the slot counter-clockwise. The fuse and its carrier will then pop out.

FUSE RATINGS

The following table lists the required fuses:

Fuses	Nominal Mains Voltage	Rating	Case Size	Recommended Replacement Part	
				Littelfuse Part Number	Digi-Key Stock Number
#1, #2 (AC)	100-240V	0.5A, 250V, Time-Delay	5×20 mm	0218.500HXP	F2416-ND
#3 (DC)	N/A	1.6A, 250V, Time-Delay	5×20 mm	021801.6HXP	F2424-ND
#4 (DC)	N/A	0.5A, 250V, Time-Delay	5×20 mm	0218.500HXP	F2416-ND

The recommended fuse manufacturer is Littelfuse (<http://www.littelfuse.com>).

Replacement fuses may be easily obtained from Digi-Key (<http://www.digikey.com>) and other distributors.

FRONT PANEL CONTROLS

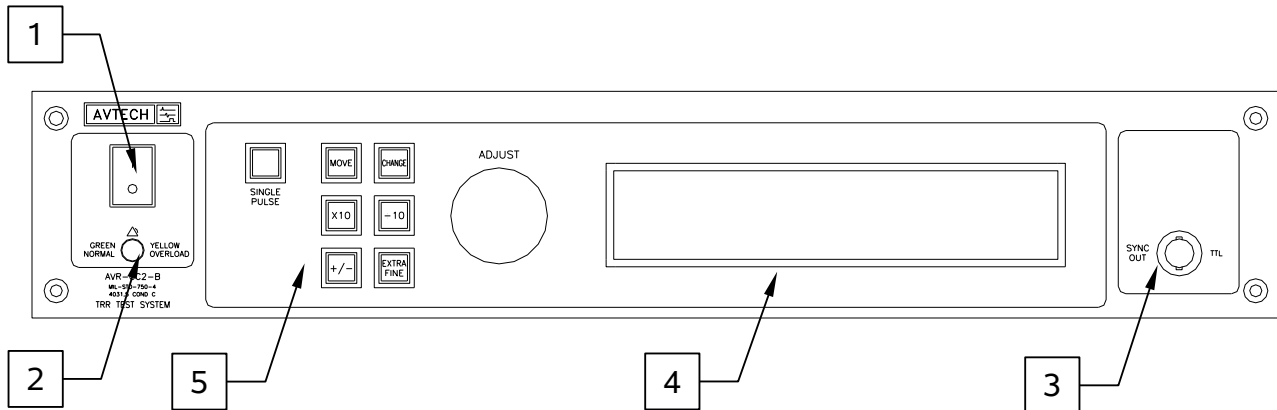

1. **POWER Switch.** This is the main power switch. When turning the instrument on, there is normally a delay of 5-10 seconds before anything is shown on the main display.

If the main menu does not appear after 30 seconds, turn off the instrument and leave it off for at least 60 seconds before applying power again.

Allow 30 seconds before re-powering an instrument that has been switched off. If the power is switched more frequently than that, the turn-on delay may be longer (up to 20 seconds) as the internal software performs filesystem checks.

2. **OVERLOAD Indicator.** When the instrument is powered, this indicator is normally green, indicating normal operation. If this indicator is yellow, an internal automatic overload protection circuit has been tripped. If the unit is overloaded (by operating at an exceedingly high duty cycle or by operating into a very low impedance), the protective circuit will disable the output of the instrument and turn the indicator light yellow. The light will stay yellow (i.e. output disabled) for about 5 seconds after which the instrument will attempt to re-enable the output (i.e. light green) for about 1 second. If the overload condition persists, the output will be disabled again (i.e. light yellow) for another 5 seconds. If the overload condition has been removed, the instrument will resume normal operation.

This overload indicator may flash yellow briefly at start-up. This is not a cause for concern.

3. **SYNC OUT.** This connector supplies a SYNC output that can be used to trigger other equipment, particularly oscilloscopes. This signal leads (or lags) the main output by a duration set by the "DELAY" controls and has an approximate amplitude of +3 Volts to $R_L > 50\Omega$ with a pulse width of approximately 100 ns.

4. LIQUID CRYSTAL DISPLAY (LCD). This LCD is used in conjunction with the keypad to change the instrument settings. Normally, the main menu is displayed, which lists the key adjustable parameters and their current values. The "Programming Manual for -B Instruments" describes the menus and submenus in detail.
5. KEYPAD.

Control Name	Function
MOVE	This moves the arrow pointer on the display.
CHANGE	This is used to enter the submenu, or to select the operating mode, pointed to by the arrow pointer.
×10	If one of the adjustable numeric parameters is displayed, this increases the setting by a factor of ten.
÷10	If one of the adjustable numeric parameters is displayed, this decreases the setting by a factor of ten.
+/-	If one of the adjustable numeric parameters is displayed, and this parameter can be both positive or negative, this changes the sign of the parameter.
EXTRA FINE	This changes the step size of the ADJUST knob. In the extra-fine mode, the step size is twenty times finer than in the normal mode. This button switches between the two step sizes.
ADJUST	This large knob adjusts the value of any displayed numeric adjustable values, such as frequency, pulse width, etc. The adjust step size is set by the "EXTRA FINE" button. When the main menu is displayed, this knob can be used to move the arrow pointer.

REAR PANEL CONTROLS

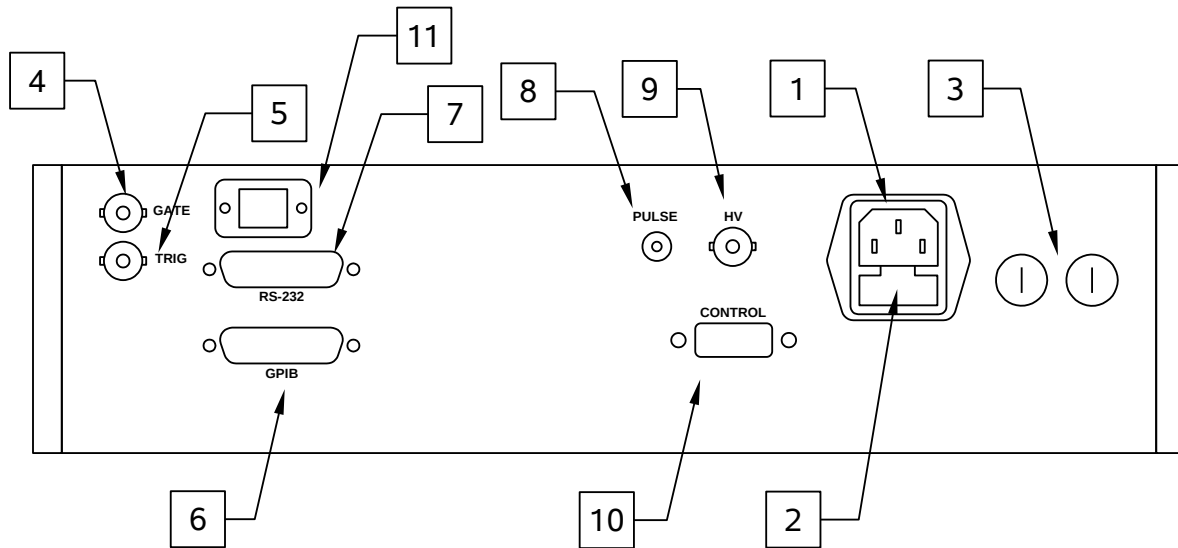

1. AC POWER INPUT. An IEC-320 C14 three-pronged recessed male socket is provided on the back panel for AC power connection to the instrument. One end of the detachable power cord that is supplied with the instrument plugs into this socket.
2. AC FUSE DRAWER. The two fuses that protect the AC input are located in this drawer. Please see the “FUSES” section of this manual for more information.
3. DC FUSES. These two fuses protect the internal DC power supplies. Please see the “FUSES” sections of this manual for more information.
4. GATE. This TTL-level (0 and +5V) logic input can be used to gate the triggering of the instrument. This input can be either active high or active low, depending on the front panel settings or programming commands. (The instrument triggers normally when this input is unconnected). When set to active high mode, this input is pulled-down to ground by a 1 k Ω resistor. When set to active low mode, this input is pulled-up to +5V by a 1 k Ω resistor.
5. TRIG. This TTL-level (0 and +5V) logic input can be used to trigger the instrument, if the instrument is set to triggering externally. The instrument triggers on the rising edge of this input. The input impedance of this input is 1 k Ω . (Depending on the length of cable attached to this input, and the source driving it, it may be desirable to add a coaxial 50 Ohm terminator to this input to provide a proper transmission line termination. The Pasternack (www.pasternack.com) PE6008-50 BNC feed-thru 50 Ohm terminator is suggested for this purpose.)
6. GPIB Connector. A standard GPIB cable can be attached to this connector to allow the instrument to be computer-controlled. See the “Programming Manual for -B

Instruments” for more details on GPIB control.

7. RS-232 Connector. A standard serial cable with a 25-pin male connector can be attached to this connector to allow the instrument to be computer-controlled. Instruments with firmware versions of 5.00 or higher require a user name (“admin”) and a password (“default”, as shipped from the factory) when logging into a serial terminal session. See the “Programming Manual for -B Instruments” for more details on RS-232 control.
8. PULSE Connector. This SMA connector provides the TTL-level trigger pulse to the test jig. This output should be connected to the corresponding input on the test jig using the supplied 2m SMA-to-SMA coaxial cable.
9. HV Connector. This BNC connector provides the high-voltage power to the test jig. This output should be connected to the corresponding input on the test jig using the supplied 2m BNC-to-BNC coaxial cable.

 Caution: Voltages as high as 150V may be present on the center conductor of this output connector. Avoid touching this conductor. Connect to this connector using standard coaxial cable, to ensure that the center conductor is not exposed.

10. CONTROL Connector. This DB-9 female connector should be connected to the corresponding connector on the test jig using the supplied DB-9 cable. This cable contains the safety interlock signals that ensure that the test jig lid is closed. The pinout is as follows:

Pin 1: To test jig switch 1.

Pin 2: To test jig switch 2.

Pin 3: +5V DC.

Pin 4: +15V DC.

Pin 5: Ground.

Pin 6: To test jig switch 1.

Pin 7: To test jig switch 2.

Pin 8: No connection.

Pin 9: Safety sensor power supply (+15V through 680 Ohms).

When the test jig lid is safely closed, Pin 1 is shorted to Pin 6, and Pin 2 is shorted to Pin 7.

11. Network Connector. (Optional feature. Present on -VXI units only.) This Ethernet connector allows the instrument to be remotely controlled using the VXI-11.3, ssh (secure shell), telnet, and http (web) protocols. See the “Programming Manual for -B Instruments” for more details.

TIMING CONTROL

BASIC TIMING CONTROL

The mainframe can be triggered by its own internal clock or by an external TTL trigger signal. In either case, two output channels respond to the trigger: PULSE and SYNC.

The PULSE output is a TTL-level signal that may either drive a 50 Ohm load, or the test jig described later. The pulse width is fixed at 2.5 us.

The SYNC pulse is a fixed-width TTL-level reference pulse used to trigger oscilloscopes or other measurement systems. When the delay is set to a positive value the SYNC pulse precedes the PULSE output. When the delay is set to a negative value the SYNC pulse follows the PULSE output.

These pulses are illustrated below, assuming internal triggering and a positive delay:

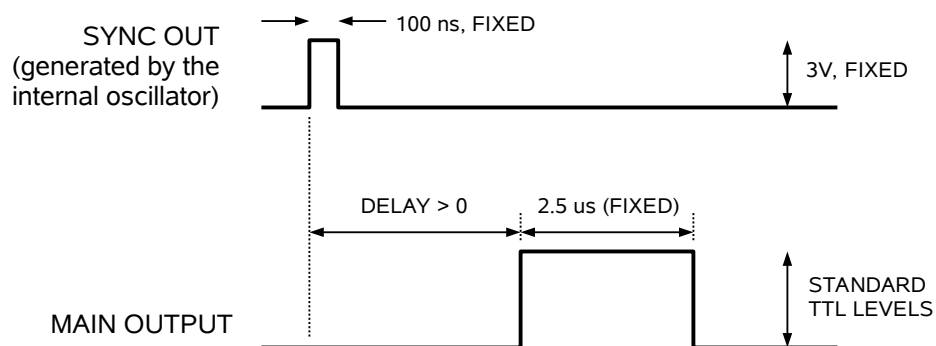

If the delay is negative, the order of the SYNC and PULSE outputs is reversed:

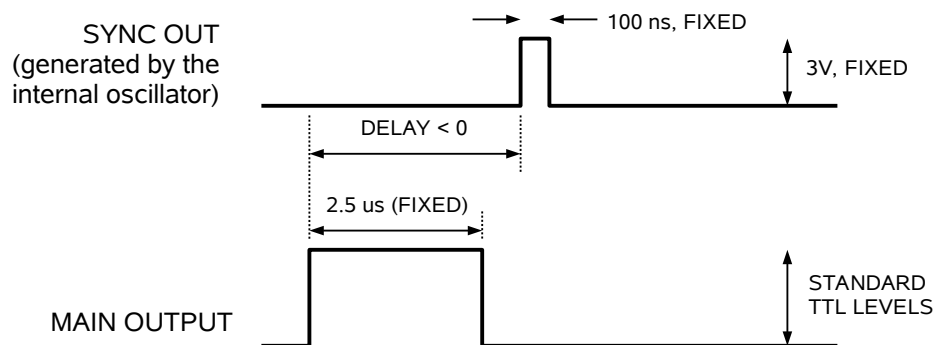

The next figure illustrates the relationship between the signal when an external TTL-level trigger is used:

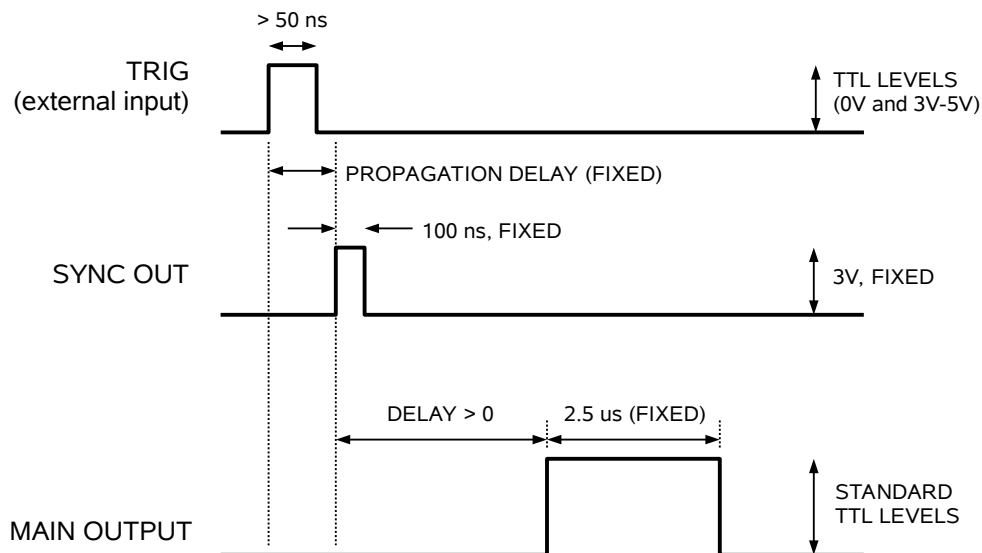

As before, if the delay is negative, the order of the SYNC and PULSE outputs is reversed.

The delay and frequency (when in the internal mode) of the PULSE output can be varied with front panel controls or via the GPIB or RS-232 computer interfaces.

TRIGGER MODES

This instrument has four trigger modes:

- Internal Trigger: the instrument controls the trigger frequency, and generates the clock internally.
- External Trigger: the instrument is triggered by an external TTL-level clock on the back-panel TRIG connector.
- Manual Trigger: the instrument is triggered by the front-panel "SINGLE PULSE" pushbutton.
- Hold Trigger: the instrument is set to not trigger at all.

These modes can be selected using the front panel trigger menu, or by using the appropriate programming commands. (See the "Programming Manual for -B Instruments" for more details.)

GATING MODES

Triggering can be suppressed by a TTL-level signal on the rear-panel GATE connector. The instrument can be set to stop triggering when this input high or low, using the front-panel gate menu or the appropriate programming commands. When gated, the output will complete the full pulse width if the output is high, and then stop triggering. Pulses are not truncated.

BASIC TEST ARRANGEMENT

The basic test arrangement for the AVR-CC2-B is shown in the simplified figure below.

The mainframe is connected to the test jig using the supplied DB9 control cable, a 2m SMA-to-SMA coaxial cable, and a 2m BNC-to-BNC coaxial cable.

The test jig is connected to the user-provided oscilloscope with the supplied SMA-to-BNC coaxial cable and feed-through terminator. The oscilloscope input impedance should be high (≥ 1 Megohm).

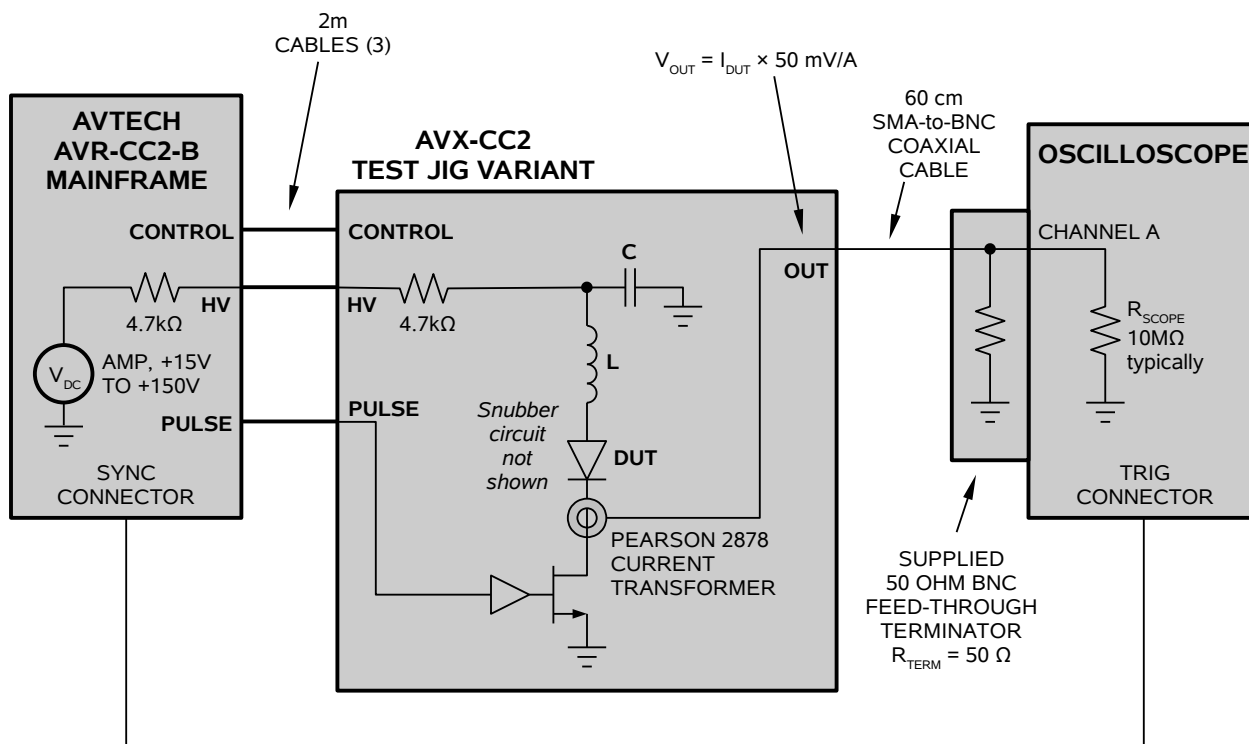

The embedded Pearson 2878 current transformer monitors the current through the DUT, and provides the output signal.

The above diagram omits the snubber circuit that is used to protect the DUT. It is shown in greater detail below:

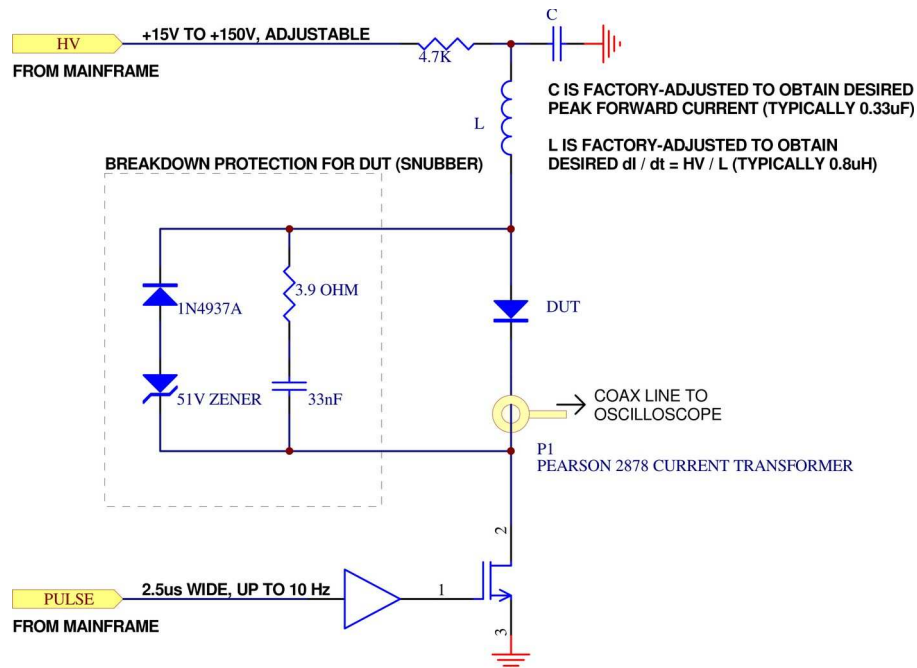

The R/C snubber and Zener diode / TVS clamp circuit are provided on each jig to avoid unnecessarily high reverse voltages that may damage the DUT, and to reduce magnitude and duration of trailing oscillations. The user should verify that the test does not generate voltages across the DUT that exceed the DUT breakdown limit.

The user may change the L, C, and snubber values on the jigs to meet different test requirements.

SAFETY INTERLOCK

The mainframe provides DC voltages of up to 150V to the test jig. For this reason, the output is automatically disabled when the test jig lid is open. The lid must be closed to obtain measurements.

MEASUREMENT THEORY

The basic theory behind this test is described in MIL-STD-750-4 Method 4031.5 Condition C, although a different circuit implementation (based on SCRs) is described in the standard. The MOSFET-based approach used in the AVR-CC2-B should provide equivalent results. (Beware that earlier versions of this standard have numerous errors in the text, and should not be relied upon.)

The AVR-CC2-B HV line charges the capacitor C between pulses. When a pulse is triggered, a MOSFET switch closes (for 2.5 us) and provides a path to discharge C to ground, through a series connection of inductance L and the DUT.

This initial leads to a large positive surge current through the DUT. The current then falls and reverses direction until the DUT switches fully off.

The figure below shows the expected waveforms, for different types of DUTs (taken from MIL-STD-750-4):

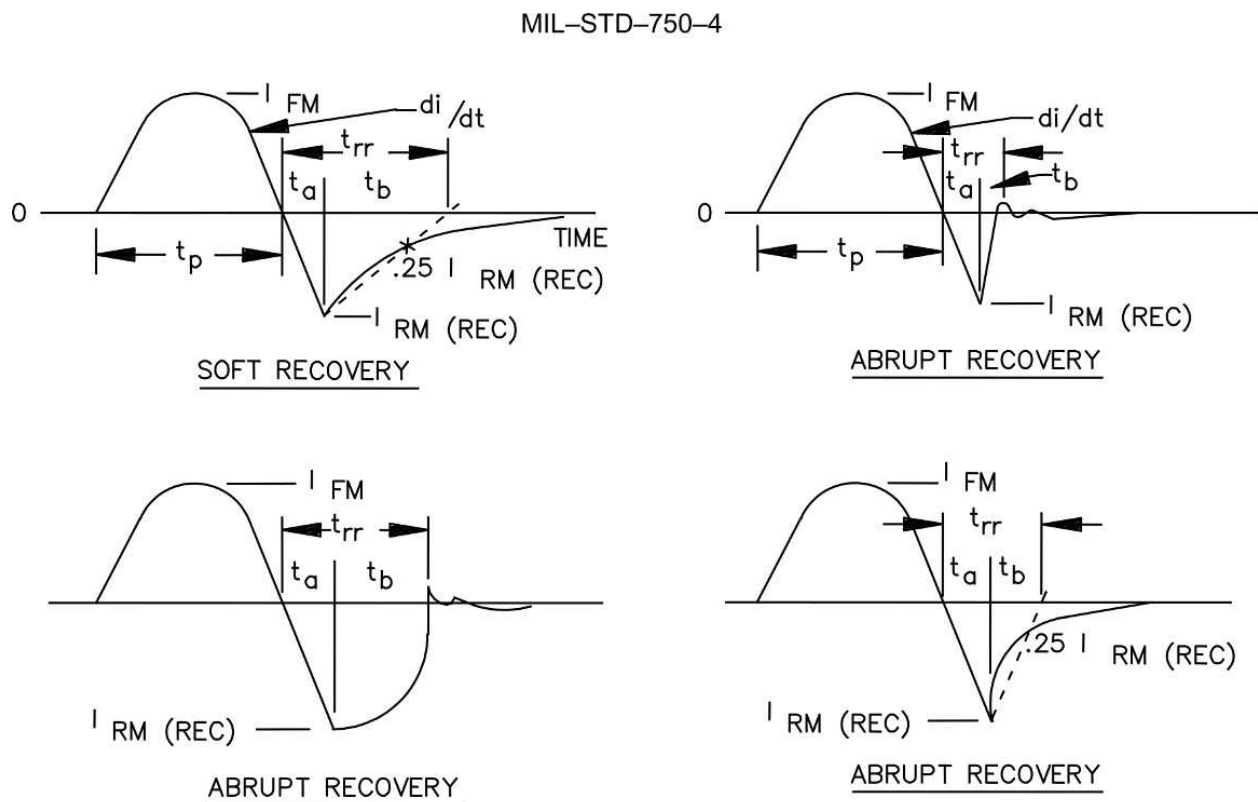

FIGURE 4031-7. Test current waveforms for various types of rectifier diodes under test in the circuit for measuring reverse recovery characteristics.

The governing equations are:

$$I_{FM} \approx HV / \sqrt{L/C}$$

$$di/dt \approx HV / L$$

Generally, HV is set at a convenient value (typically +110V), and L and C are chosen to obtain the desired di/dt and I_{FM} . HV is set from the instrument front panel (using the AMP menu), or by computer command. L and C are hard-wired components (although the user may modify these components by desoldering and resoldering them).

The duration of the forward portion of the transient (t_p in the figure above) is determined by the transient response of the LC circuit. The MOSFET switch is closed for 2.5 us, so that will impose an upper limit on $t_p + t_{RR}$.

TEST JIG MECHANICAL ASPECTS

One or more test jigs are supplied with the instrument, depending on the customizations requested by the user at the time of ordering.

All test jigs share a basic mechanical layout:

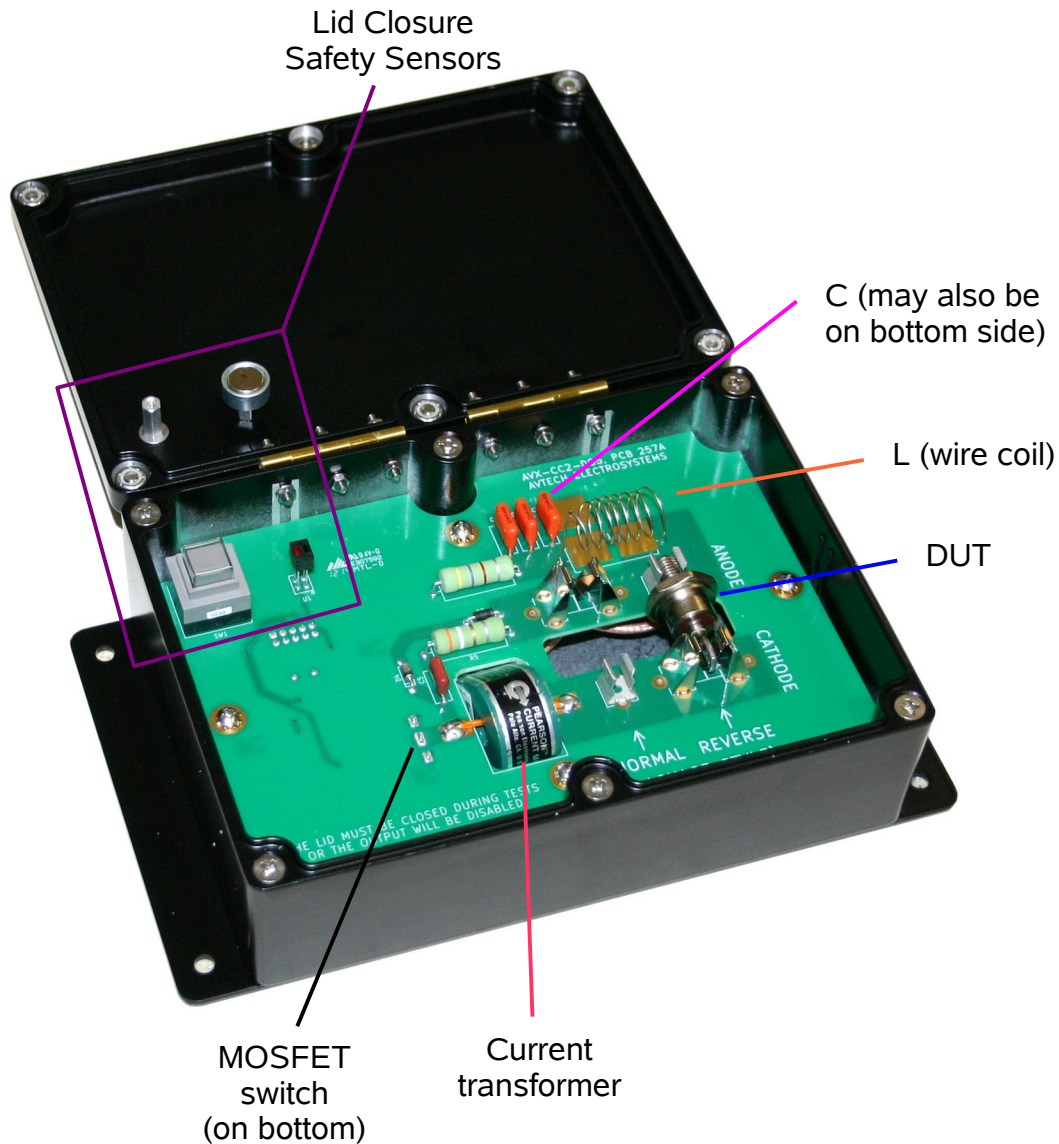

The instrument will not be damaged if the diode is installed with the incorrect orientation (i.e., with the anode and cathode reversed). However, incorrect waveforms will be generated.

The inductor L is implemented as a coil of wire. Take care not to bump it, as this may change its inductance. (Ferrite inductors should be avoided in this application, because ferrite saturation effects may introduce unexpected and unwelcome behaviour.)

The capacitor C actually consists of several capacitors in parallel, to handle the high surge currents. The capacitors may be installed on either side of the PCB.

TEST JIG CONNECTORS

The PULSE, HV, CONTROL, and OUT connectors are on the rear of the jig, below the hinges:



SPECIFIC TEST JIGS AND TYPICAL RESULTS

Obtaining meaningful results with the AVR-CC2-B requires care, experience, and an understanding of diode transient behavior and the impact of inductive and capacitive parasitics. To assist the user, typical results are provided below. The user should be able to reliably duplicate these results.

AVX-CC2-DO5-MS1

This jig accepts Microsemi 1N6306 diodes. The values of L (nominally 846 nH) and C (nominally 0.34 uF) are selected to provide $I_{FM} \approx +70A$ and $di/dt \approx 130 A/us$ when HV = +110V.

A 1N6306 is shown installed below:

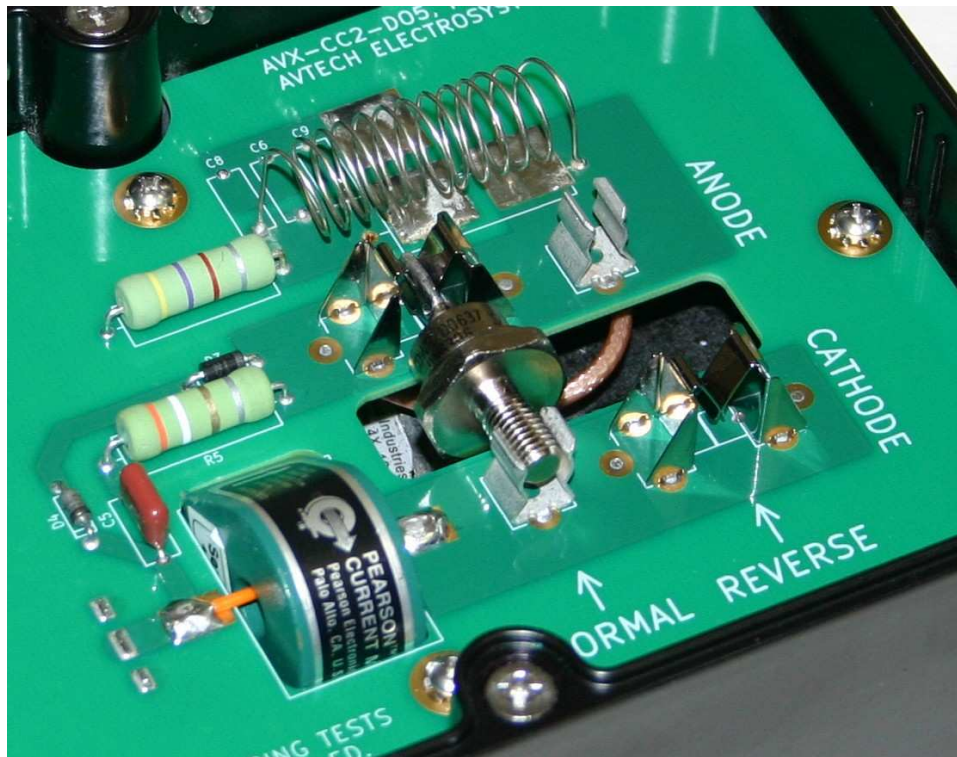

Metal clips accept both ends of the device. Two sets of clips are provided, to accept normal or reverse diode orientations. The device shown above has a “normal” orientation.

The capacitors comprising “C” are installed on the bottom side of the board.

The inductor “L” is the coil of wire seen above.

With this arrangement, and HV = +110V, the following waveform is obtained:

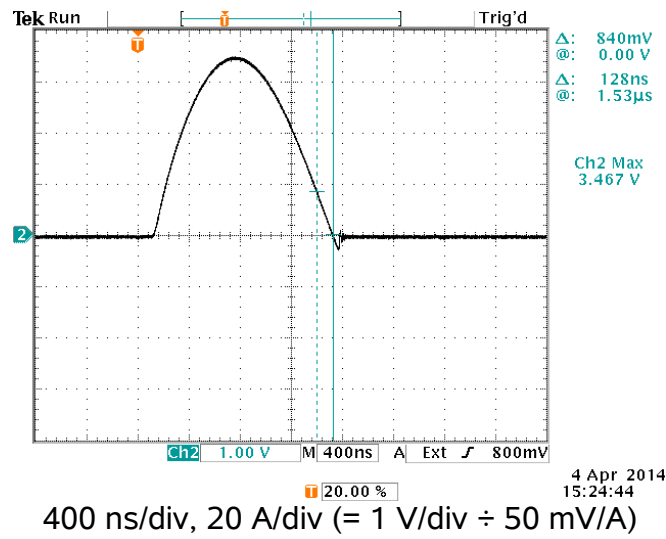

The cursors show how to calculate di/dt :

$$\begin{aligned} di/dt &= (840 \text{ mV} \div 50 \text{ mV/A}) / 0.128 \text{ us} \\ &= 131.25 \text{ A/us} \end{aligned}$$

The peak current is:

$$I_{FM} = 3.467 \text{ V} \div 50 \text{ mV/A} = 69.34 \text{ A}$$

Zooming in on the reverse transient gives:

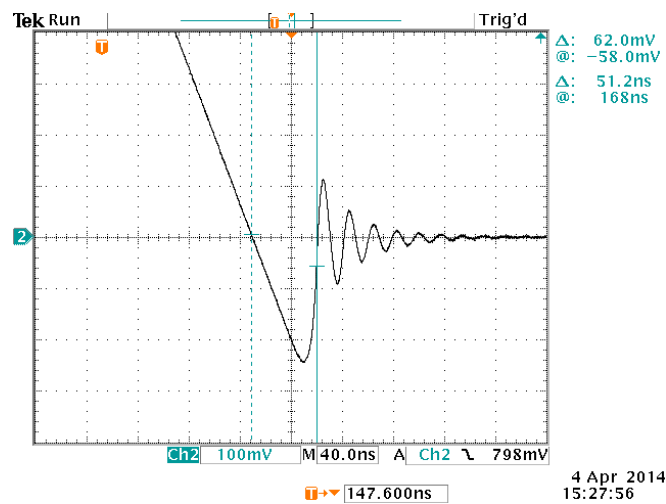

From this waveform, $t_{RR} = 51.2 \text{ ns}$. MIL-PRF-19500/550C specified a maximum t_{RR} of 60 ns under these conditions, so the DUT passes!

AVX-CC2-DO5-MS2

This jig accepts Microsemi diodes labeled “MSC 1231 D8051GM”. The values of L (nominally 500 nH) and C (nominally 0.066 uF) are selected to provide IFM \approx +40A and $di/dt \approx 220$ A/us when HV = +110V.

A device is shown installed below:



Metal clips accept both ends of the device. Two sets of clips are provided, to accept normal or reverse diode orientations. The device shown above has a “reverse” orientation.

The capacitors comprising “C” are installed on both sides of the board.

The inductor “L” is the coil of wire seen above.

With this arrangement, and HV = +110V, the following waveform is obtained:

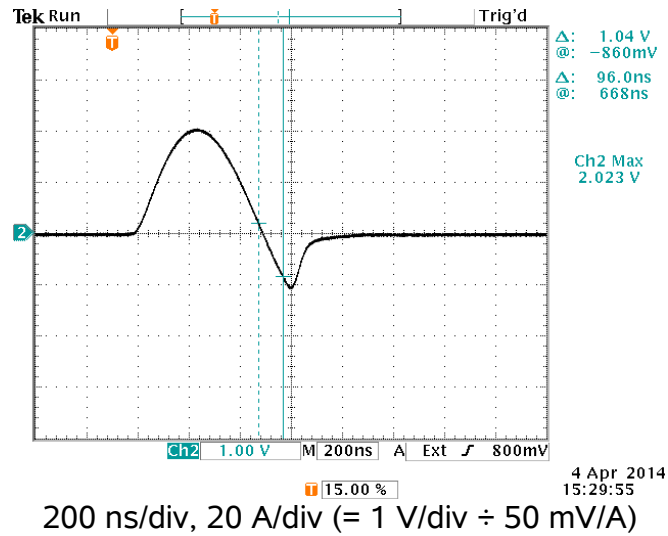

The cursors show how to calculate di/dt :

$$\begin{aligned} di/dt &= (1.04\text{V} \div 50 \text{ mV/A}) / 0.096 \text{ us} \\ &= 216.7 \text{ A/us} \end{aligned}$$

The peak current is:

$$I_{FM} = 2.023\text{V} \div 50 \text{ mV/A} = 40.46 \text{ A}$$

Zooming in on the reverse transient gives:

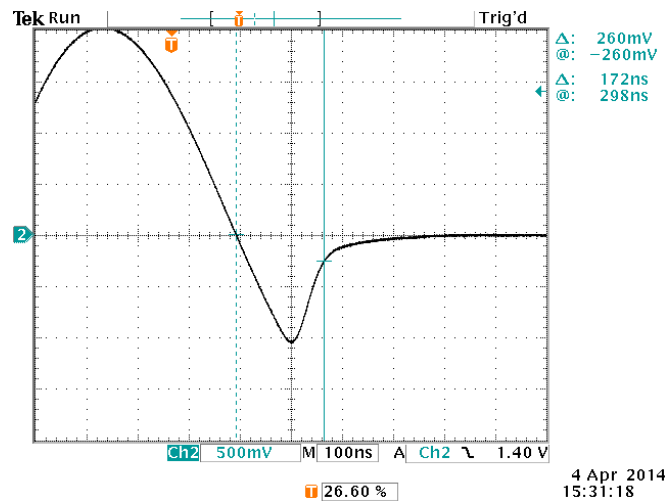

From this waveform, $t_{RR} = 172 \text{ ns}$.

TROUBLESHOOTING

If you obtain “strange” output waveforms, or unexpected values of t_{RR} , keep these points in mind:

- 1) The test jig output should be terminated with 50 Ohms. Use the supplied terminator, and make sure the oscilloscope input impedance is high.
- 2) Keep device lead lengths as short as possible, to minimize parasitic inductance.
- 3) The test jig lid must be closed, or the pulser output will be disabled.
- 4) Avoid hitting the inductor L. If the coils touch each other, the total inductance will be reduced and the peak current and di/dt will change. If this occurs, simply bend the coils back into shape and confirm that you obtain the expected results.

For technical support, contact info@avtechpulse.com. Sample waveforms and digital photos of your setup are always helpful!

PROGRAMMING YOUR PULSE GENERATOR

KEY PROGRAMMING COMMANDS

The “Programming Manual for -B Instruments” describes in detail how to connect the pulse generator to your computer, and the programming commands themselves. A large number of commands are available; however, normally you will only need a few of these. Here is a basic sample sequence of commands that might be sent to the instrument after power-up:

*rst	(resets the instrument)
trigger:source internal	(selects internal triggering)
frequency 1000 Hz	(sets the frequency to 100 Hz)
volt 110	(sets the HV bias to +110V)
output on	(turns on the output)

For triggering a single event, this sequence would be more appropriate:

*rst	(resets the instrument)
trigger:source hold	(turns off all triggering)
output on	(turns on the output)
volt 110	(sets the HV bias to +110V)
trigger:source immediate	(generates a single non-repetitive trigger event)
trigger:source hold	(turns off all triggering)
output off	(turns off the output)

To set the instrument to trigger from an external TTL signal applied to the rear-panel TRlg connector, use:

*rst	(resets the instrument)
trigger:source external	(selects external triggering)
volt 110	(sets the HV bias to +110V)
output on	(turns on the output)

These commands will satisfy 90% of your programming needs.

ALL PROGRAMMING COMMANDS

For more advanced programmers, a complete list of the available commands is given below. These commands are described in detail in the “Programming Manual for -B Instruments”. (Note: this manual also includes some commands that are not implemented in this instrument. They can be ignored.)

<u>Keyword</u>	<u>Parameter</u>	<u>Notes</u>
LOCAL		
OUTPut:		
:[STATe]	<boolean value>	
:PROTection		
:TRIPped?		[query only]
REMOTE		
[SOURce]:		
:FREQuency		
[:CW FIXed]	<numeric value>	
[SOURce]:		
:PULSe		
:PERiod	<numeric value>	
:WIDTh	<numeric value>	
:DELay	<numeric value>	
:GATE		
:LEVel	High Low	
[SOURce]:		
:CURRent		
[:LEVel]		
[:IMMediate]		
[:AMPLitude]	<numeric value>	
:PROTection		
:TRIPped?		[query only]
:SLEW	<numeric value>	
:VOLTage		
[:LEVel]		
[:IMMediate]		
[:AMPLitude]	<numeric value>	
:PROTection		
:TRIPped?		[query only]
STATUS:		
:OPERation		
:[EVENT]?		[query only, always returns "0"]
:CONDition?		[query only, always returns "0"]
:ENABle	<numeric value>	[implemented but not useful]
:QUESTionable		
:[EVENT]?		[query only, always returns "0"]
:CONDition?		[query only, always returns "0"]
:ENABle	<numeric value>	[implemented but not useful]
SYSTEM:		
:COMMunicate		
:GPIB		
:ADDRes	<numeric value>	
:SERial		
:CONTRol		
:RTS	ON IBFull RFR	
:[RECeive]		

:BAUD	1200 2400 4800 9600	
:BITS	7 8	
:ECHO	<boolean value>	
:PARity		
:[TYPE]	EVEN ODD NONE	
:SBITS	1 2	
:ERRor		
:[NEXT]?		[query only]
:COUNT?		[query only]
:VERSion?		[query only]
TRIGger:		
:SOURce	INTernal EXTernal MANual HOLD IMMEDIATE	
*CLS		[no query form]
*ESE	<numeric value>	
*ESR?		[query only]
*IDN?		[query only]
*OPC		
*SAV	0 1 2 3	[no query form]
*RCL	0 1 2 3	[no query form]
*RST		[no query form]
*SRE	<numeric value>	
*STB?		[query only]
*TST?		[query only]
*WAI		[no query form]

MECHANICAL INFORMATION

TOP COVER REMOVAL

If necessary, the interior of the instrument may be accessed by removing the four Phillips screws on the top panel. With the four screws removed, the top cover may be slid back (and off).

 Always disconnect the power cord and allow the instrument to sit unpowered for 10 minutes before opening the instrument. This will allow any internal stored charge to discharge.

There are no user-adjustable internal circuits. For repairs other than fuse replacement, please contact Avtech (info@avtechpulse.com) to arrange for the instrument to be returned to the factory for repair. Service is to be performed solely by qualified service personnel.

 Caution: High voltages are present inside the instrument during normal operation. Do not operate the instrument with the cover removed.

RACK MOUNTING

A rack mounting kit is available. The -R5 rack mount kit may be installed after first removing the one Phillips screw on the side panel adjacent to the front handle.

ELECTROMAGNETIC INTERFERENCE

To prevent electromagnetic interference with other equipment, all used outputs should be connected to shielded loads using shielded coaxial cables. Unused outputs should be terminated with shielded coaxial terminators or with shielded coaxial dust caps, to prevent unintentional electromagnetic radiation. All cords and cables should be less than 3m in length.

MAINTENANCE

REGULAR MAINTENANCE

This instrument does not require any regular maintenance.

On occasion, one or more of the four rear-panel fuses may require replacement. All fuses can be accessed from the rear panel. See the “FUSES” section for details.

CLEANING

If desired, the interior of the instrument may be cleaned using compressed air to dislodge any accumulated dust. (See the “TOP COVER REMOVAL” section for instructions on accessing the interior.) No other cleaning is recommended.

TRIGGER DAMAGE

The rear-panel TRIG input, used in the external trigger mode, is protected by a diode clamping circuit. However, the protection circuit is not foolproof, and it is possible for a grossly excessive signal to damage the trigger circuitry on the main timing control board (the 4×10 inch board on the right side of the instrument).

The IC that is most likely to fail under these conditions is installed in a socket. It is a standard TTL IC in a 16-pin plastic DIP package, model 74F151 or equivalent.

If you suspect that this IC has been damaged, turn off the power and replace this IC. It may be replaced by a 74F151, 74LS151, 74ALS151, or 74HCT151.

WIRING DIAGRAMS

WIRING OF AC POWER

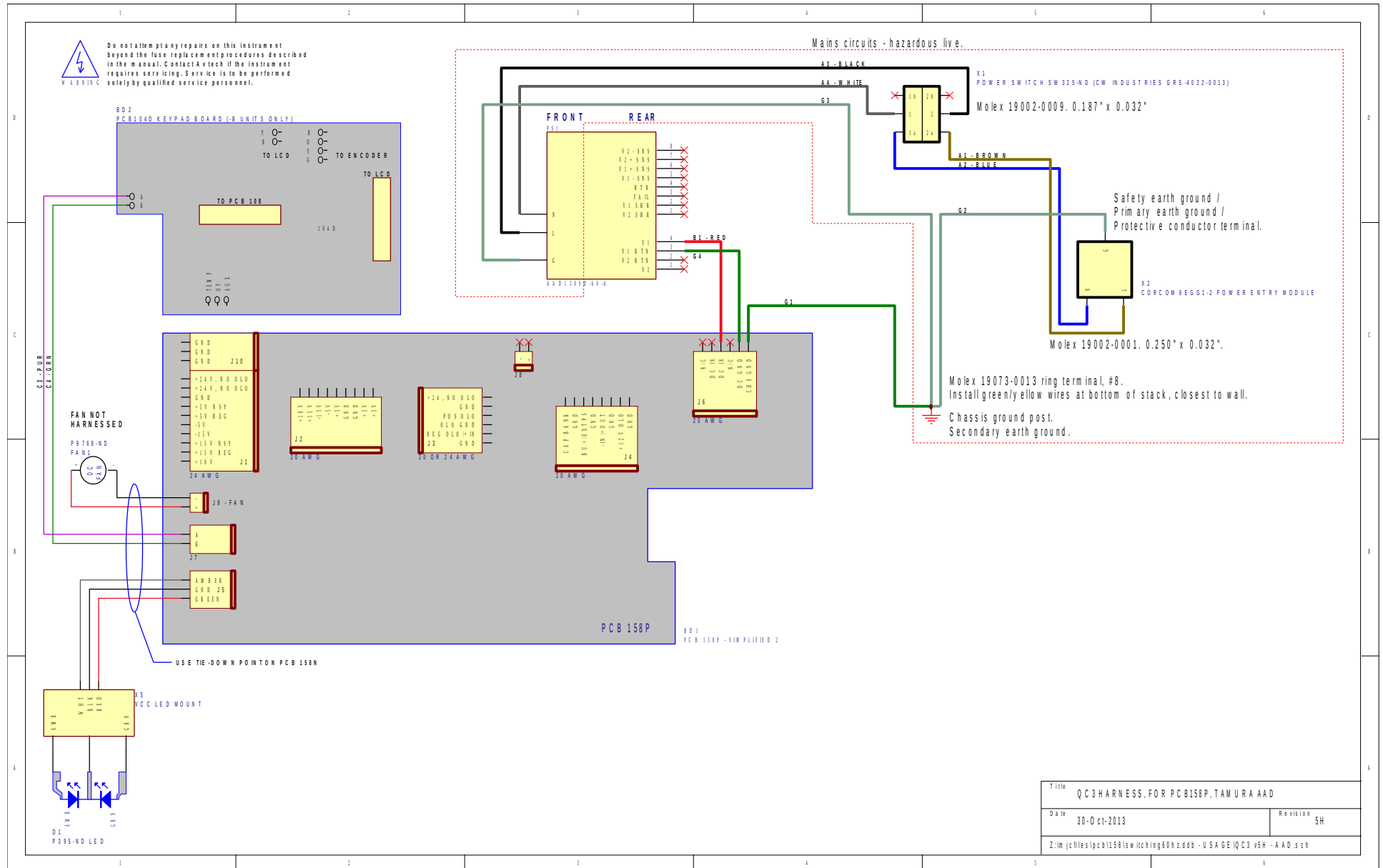

PCB 158P - LOW VOLTAGE POWER SUPPLY, 1/3

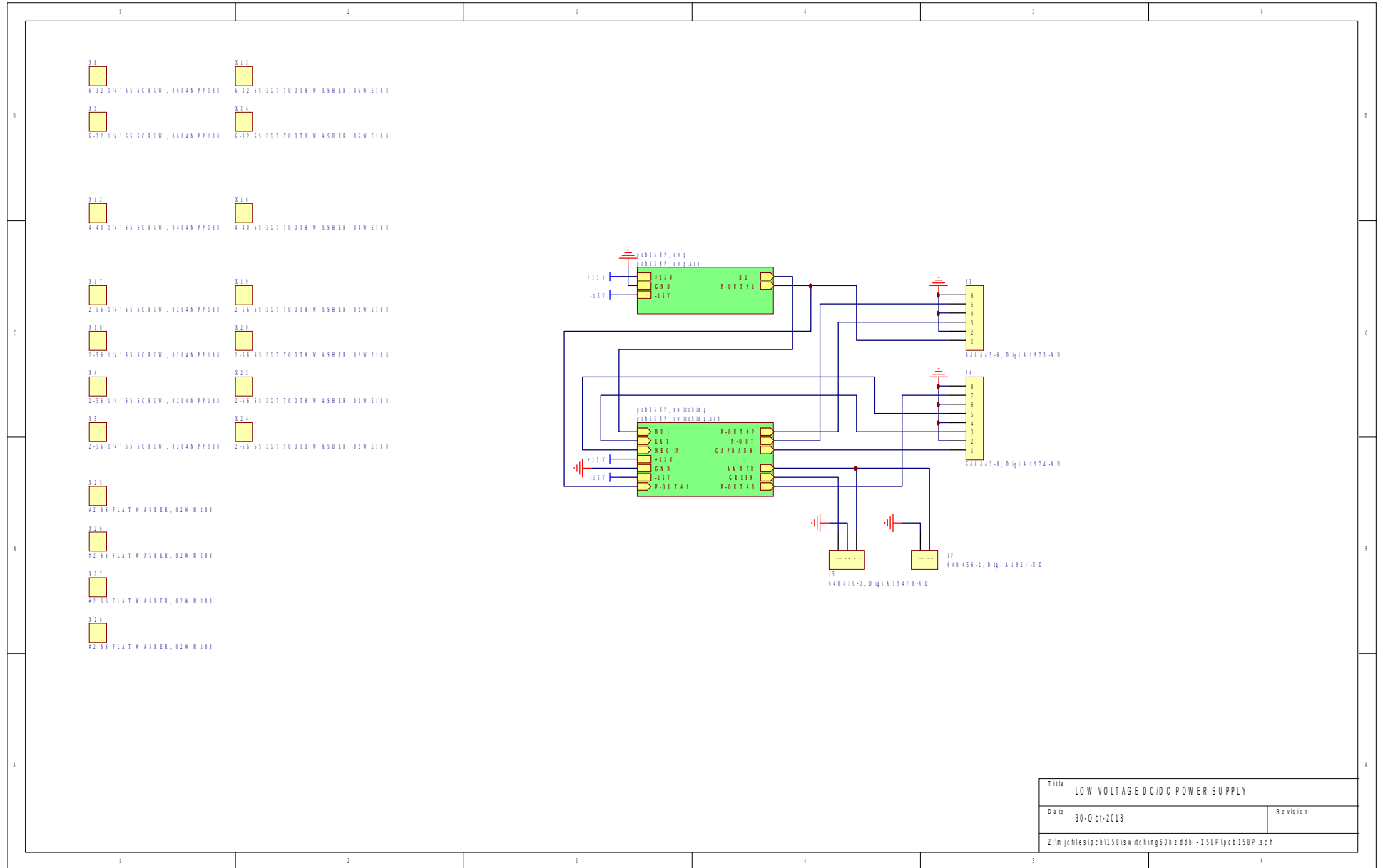

Title		LOW VOLTAGE DC/DC POWER SUPPLY
Date	30-Oct-2013	Revision
Z:\m\jcf\files\pcb\158\sw\hching60hz.ddd - 158P\pcb 158P.sch		

PCB 235A - HIGH VOLTAGE DC POWER SUPPLY

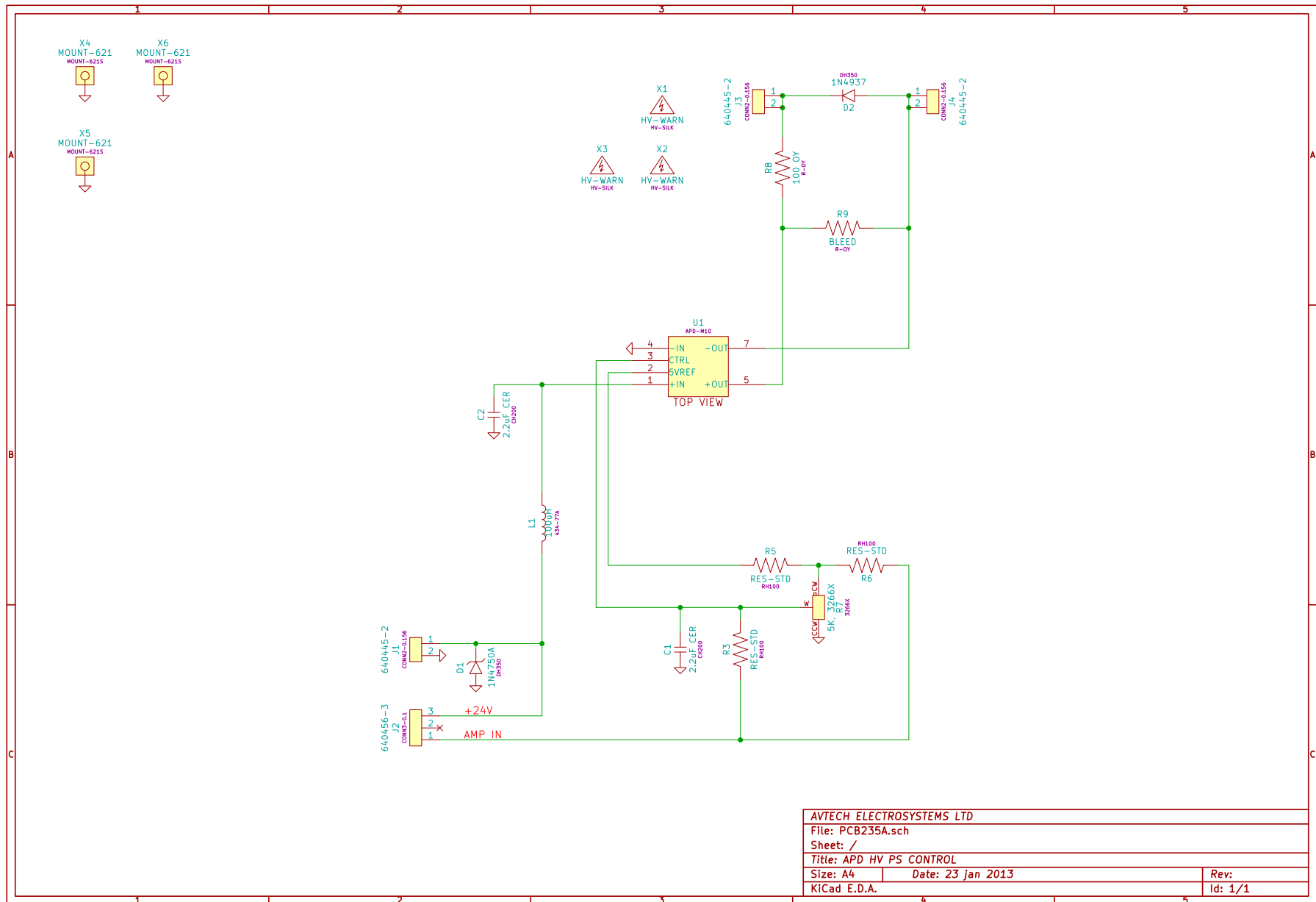

AVTECH ELECTROSYSTEMS LTD		
File: PCB235A.sch		
Sheet: /		
Title: APD HV PS CONTROL		
Size: A4	Date: 23 Jan 2013	Rev:
KiCad E.D.A.		Id: 1/1

PCB 104E - KEYPAD / DISPLAY BOARD, 1/3

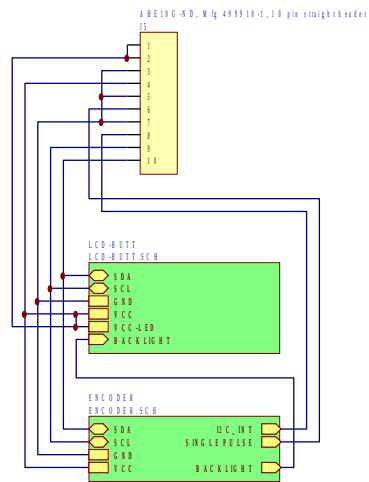

Title		PANEL TOP-LEVEL SCHEMATIC	
Date	3-Mar-2011	Revision	
Z:\m\j\files\pcb\104e\keypad-2010.ddb - Documents\Panel\rd.pjt			

PCB 104E - KEYPAD / DISPLAY BOARD, 2/3

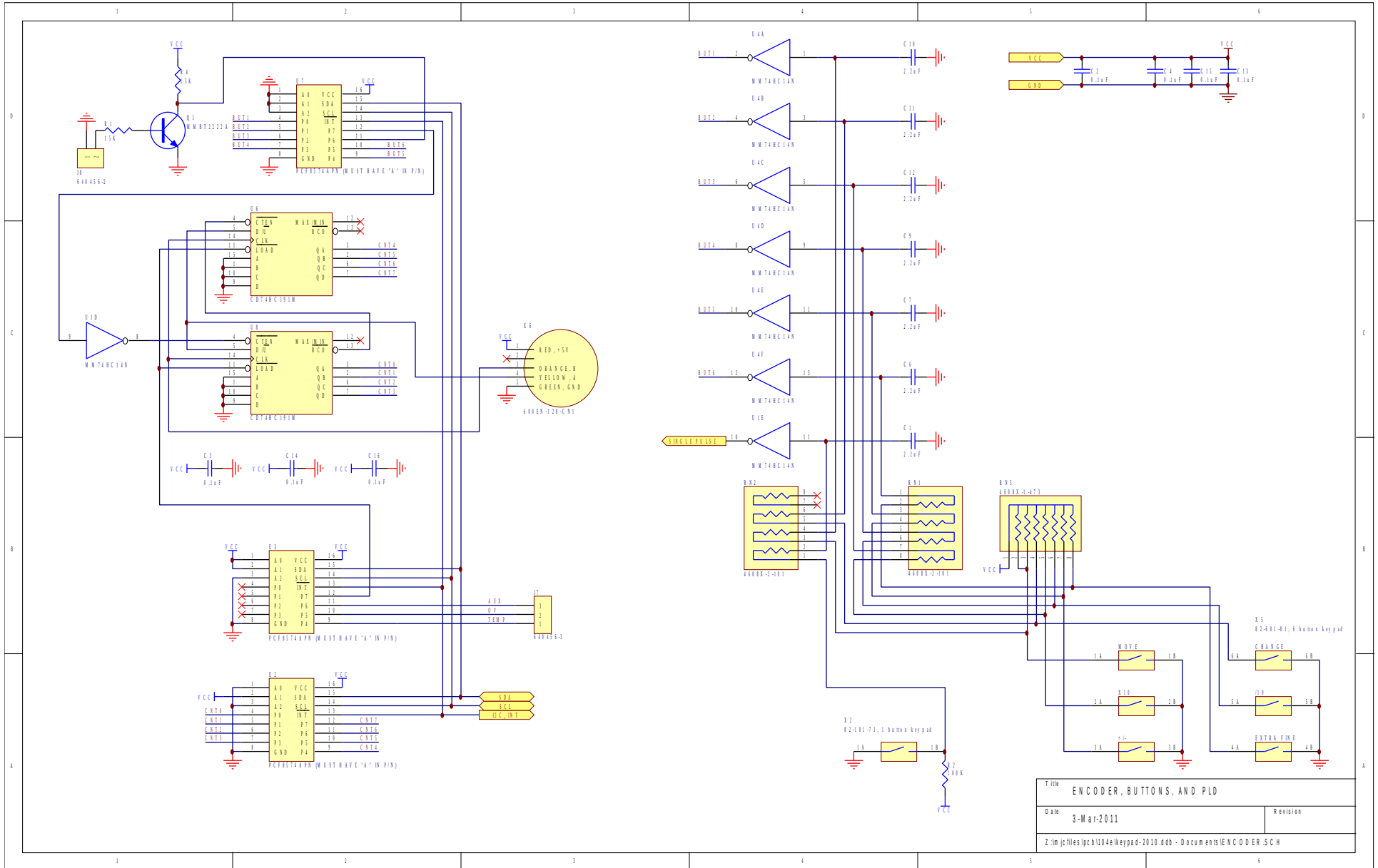

PCB 104E - KEYPAD / DISPLAY BOARD, 3/3

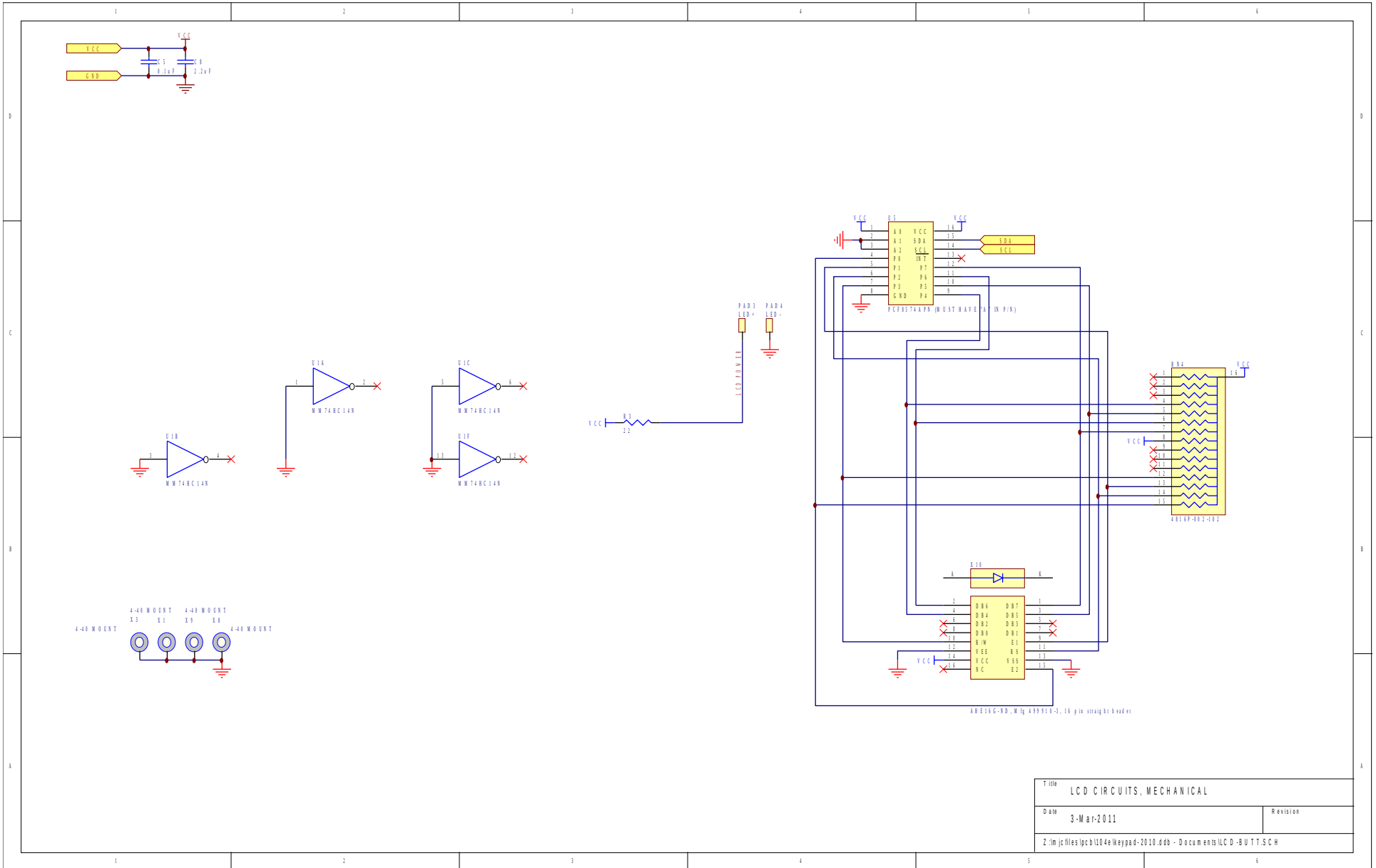

PCB 201B - INTERLOCK

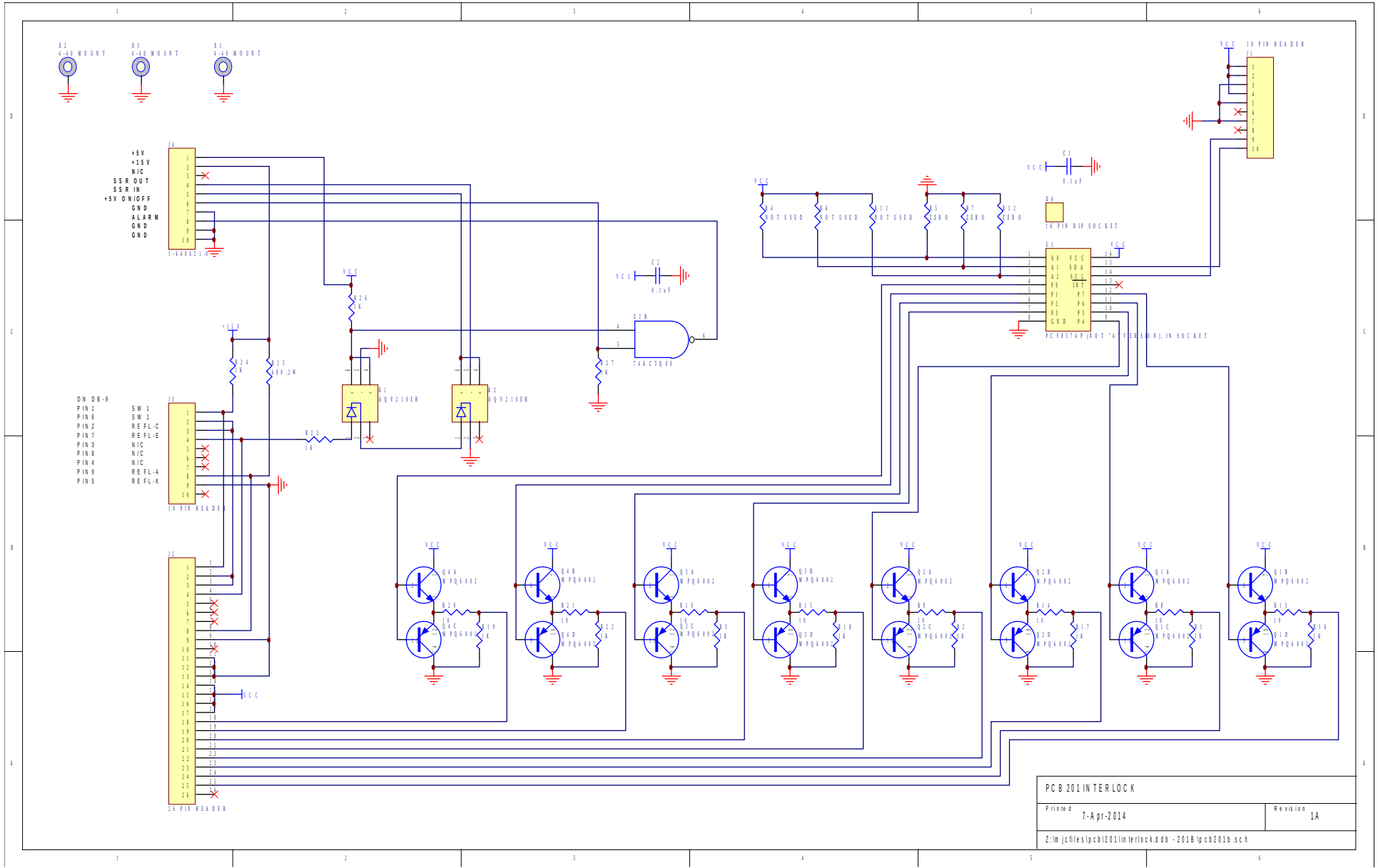

PCB 201 INTERLOCK	
Printed 7-Apr-2014	Revision 1A
Z:\m\jcf\files\pcb\201\interlock\ddb - 2018\pcb201b.sch	

MAIN WIRING

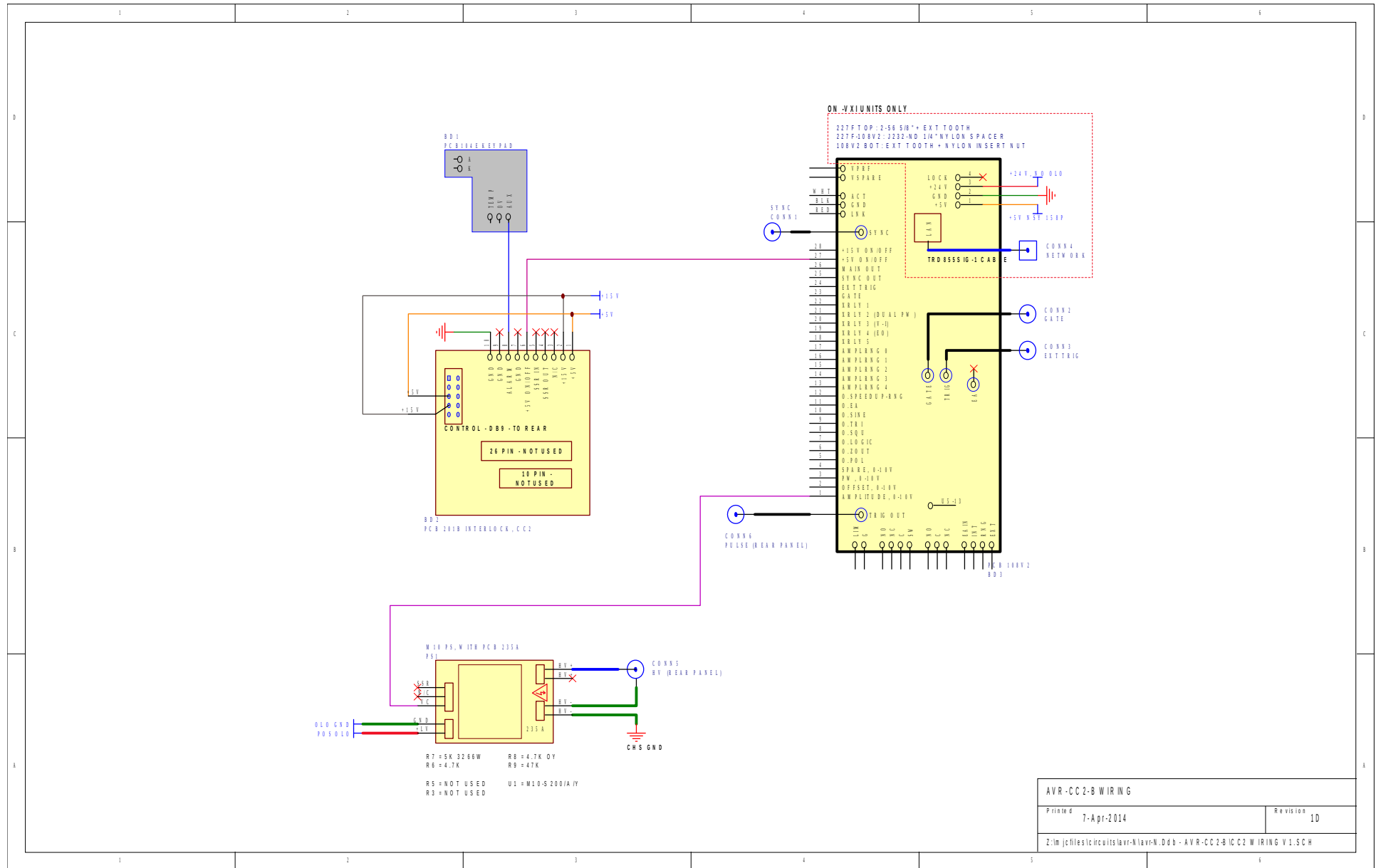

TEST JIG WIRING (AVX-CC2-DO5-MS1, AVX-CC2-DO5-MS2)

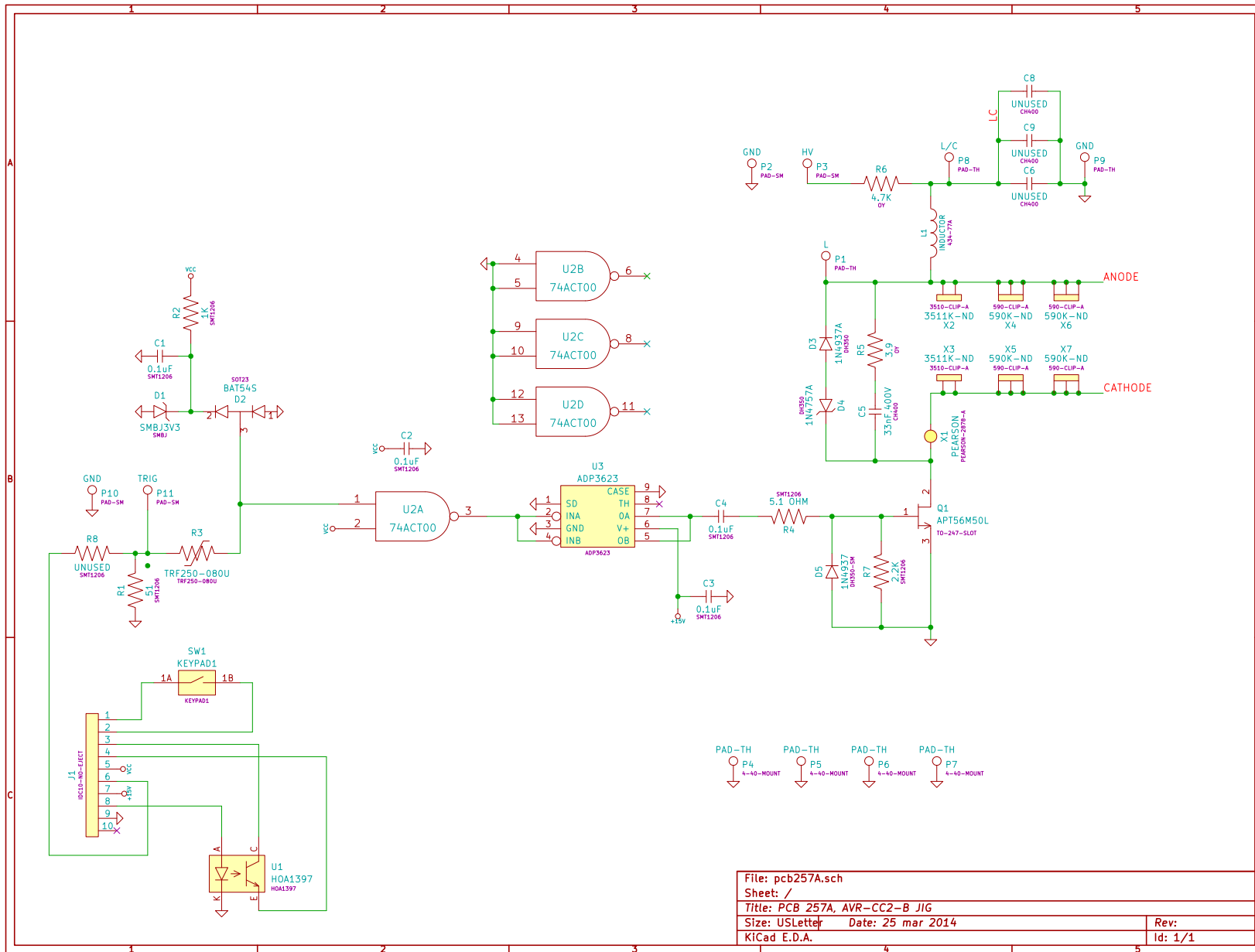

File: pcb257A.sch
 Sheet: /
 Title: PCB 257A, AVR-CC2-B JIG
 Size: USLetter Date: 25 mar 2014 Rev:
 KiCad E.D.A. Id: 1/1

PERFORMANCE CHECK SHEET