



AVTECH ELECTROSYSTEMS LTD.

NANOSECOND WAVEFORM ELECTRONICS
SINCE 1975

info@avtechpulse.com
<http://www.avtechpulse.com/>

Tel: 888-670-8729 (USA & Canada) or +1-613-686-6675 (Intl)
Fax: 800-561-1970 (USA & Canada) or +1-613-686-6679 (Intl)

BOX 5120, LCD MERIVALE
OTTAWA, CANADA K2C3H5

INSTRUCTIONS

MODELS AVR-DV1-B

± 1000 VOLT

PHOTOTRIAC

dV/dt TEST SYSTEM

SERIAL NUMBER: 14004

WARRANTY

Avtech Electrosystems Ltd. warrants products of its manufacture to be free from defects in material and workmanship under conditions of normal use. If, within one year after delivery to the original owner, and after prepaid return by the original owner, this Avtech product is found to be defective, Avtech shall at its option repair or replace said defective item. This warranty does not apply to units which have been disassembled, modified or subjected to conditions exceeding the applicable specifications or ratings. This warranty is the extent of the obligation assumed by Avtech with respect to this product and no other warranty or guarantee is either expressed or implied.

TECHNICAL SUPPORT

Phone: 888-670-8729 (USA & Canada) or +1-613-686-6675 (International)

Fax: 800-561-1970 (USA & Canada) or +1-613-686-6679 (International)

E-mail: info@avtechpulse.com

World Wide Web: <http://www.avtechpulse.com>

TABLE OF CONTENTS

WARRANTY.....	2
TECHNICAL SUPPORT.....	2
TABLE OF CONTENTS.....	3
INTRODUCTION.....	5
SPECIFICATIONS.....	7
REGULATORY NOTES.....	8
FCC PART 18.....	8
EC DECLARATION OF CONFORMITY.....	8
DIRECTIVE 2011/65/EU (RoHS).....	9
DIRECTIVE 2002/96/EC (WEEE).....	9
FIRMWARE LICENSING.....	10
INSTALLATION.....	11
VISUAL CHECK.....	11
POWER RATINGS.....	11
CONNECTION TO THE POWER SUPPLY.....	11
PROTECTION FROM ELECTRIC SHOCK.....	12
ENVIRONMENTAL CONDITIONS.....	13
LABVIEW DRIVERS.....	13
FUSES.....	14
AC FUSE REPLACEMENT.....	14
DC FUSE REPLACEMENT.....	15
FUSE RATINGS.....	15
FRONT PANEL CONTROLS.....	16
REAR PANEL CONTROLS.....	18
TIMING CONTROL.....	20
BASIC PULSE CONTROL.....	20
TRIGGER MODES.....	22
PULSE WIDTH MODES.....	22
GATING MODES.....	22
USING THE TEST JIG.....	23
ADJUSTING “T”.....	23
ACCESSIBLE VOLTAGES.....	24

TEST JIG MECHANICAL ASPECTS.....	25
AVX-DVDT-EVC TEST JIG.....	25
TYPICAL RESULTS.....	27
WITH NO DUT.....	27
TYPICAL RESULTS – FAIRCHILD MOC3052M.....	28
TYPICAL RESULTS – FAIRCHILD MOC3062M.....	29
COMMENTS.....	30
PROGRAMMING YOUR PULSE GENERATOR.....	31
KEY PROGRAMMING COMMANDS.....	31
ALL PROGRAMMING COMMANDS.....	32
MECHANICAL INFORMATION.....	34
TOP COVER REMOVAL.....	34
RACK MOUNTING.....	34
ELECTROMAGNETIC INTERFERENCE.....	34
MAINTENANCE.....	35
REGULAR MAINTENANCE.....	35
CLEANING.....	35
TRIGGER DAMAGE.....	35
WIRING DIAGRAMS.....	36
WIRING OF AC POWER.....	36
PCB 158R5 - LOW VOLTAGE POWER SUPPLY.....	37
PCB 284B - HIGH VOLTAGE DC POWER SUPPLY.....	38
PCB 156D - POLARITY CONTROL PCB.....	39
PCB 104G - KEYPAD / DISPLAY BOARD.....	40
INTERLOCK CIRCUIT.....	41
MAIN WIRING.....	42
PCB 200B - TEST JIG.....	43
TEST JIG WIRING.....	44
PERFORMANCE CHECK SHEET.....	45

Manual Reference: /files/officefiles/instructword/avr-dv/AVR-DV1-B,ed4.odt.

Last modified February 29, 2024.

Copyright © 2024 Avtech Electrosystems Ltd, All Rights Reserved.

INTRODUCTION

Model AVR-DV1-B is a high performance, GPIB and RS232-equipped pulser designed to produce waveforms suitable for phototriac dV/dt test requirements.

More specifically, the AVR-DV1-B mainframe generates 200 ns to 200 us pulses with amplitudes adjustable up to +1000V or -1000V. This pulse is applied to the supplied test jig. An adjustable series resistance and a fixed capacitance are present in the test jig. Together with the 50 Ohm output impedance in the mainframe, these generate a low-pass filter. The resulting 1%-63.2% rise time (“T”) is <125 ns to > 1.1 us, approximately. Units with the -FTR option have enhanced faster minimum rise times - see the table below.

By varying “T”, different dV/dt rates can be obtained. Normally, the user will set the amplitude to a specific value, and increase the dV/dt value until the device under test (a phototriac) triggers, causing the voltage across the DUT to fall to zero.

	Standard units	Units with -FTR option
Fastest	$T_{MIN} = \leq 125 \text{ ns at } 400\text{V (} 2.02 \text{ kV/us at } 400\text{V)}$ $T_{MIN} = \leq 125 \text{ ns at } 600\text{V (} 3.03 \text{ kV/us at } 600\text{V)}$ $T_{MIN} = \leq 125 \text{ ns at } 800\text{V (} 4.04 \text{ kV/us at } 800\text{V)}$ $T_{MIN} = \leq 125 \text{ ns at } 1000\text{V (} 5.06 \text{ kV/us at } 1000\text{V)}$	$T_{MIN} = \leq 16.8 \text{ ns at } 400\text{V (} 15.0 \text{ kV/us at } 400\text{V)}$ $T_{MIN} = \leq 19 \text{ ns at } 600\text{V (} 20.0 \text{ kV/us at } 600\text{V)}$ $T_{MIN} = \leq 22 \text{ ns at } 800\text{V (} 23.0 \text{ kV/us at } 800\text{V)}$ $T_{MIN} = \leq 25 \text{ ns at } 1000\text{V (} 25.3 \text{ kV/us at } 1000\text{V)}$
Slowest	$T_{MAX} \geq 1.1 \text{ us at } 400\text{V (} 0.23 \text{ kV/us at } 400\text{V)}$ $T_{MAX} \geq 1.1 \text{ us at } 600\text{V (} 0.34 \text{ kV/us at } 600\text{V)}$ $T_{MAX} \geq 1.1 \text{ us at } 800\text{V (} 0.46 \text{ kV/us at } 800\text{V)}$ $T_{MAX} \geq 1.1 \text{ us at } 1000\text{V (} 0.57 \text{ kV/us at } 1000\text{V)}$	

The AVR-DV1-B model includes one AVX-DVDT-EVC test jig. The instrument mainframe is connected to the test jig using one coaxial cable and one DB-9 control cable. The test jig contains a ZIF socket suitable for a 6 pin DIP. The test jig has a hinged lid, which must be fully closed to protect the user from high voltages. The output will be automatically disabled if the lid is left open.

The AVR-DV1-B must be used in conjunction with a high-voltage oscilloscope probe (preferably with a BNC input connector) and an oscilloscope.

The AVR-DV1-B includes an internal trigger source, but it can also be triggered or gated by an external source. A front-panel pushbutton can also be used to trigger the instrument.

The AVR-DV1-B features front panel keyboard and adjust knob control of the output pulse parameters along with a four line by 40-character backlit LCD display of the output amplitude, pulse repetition frequency, and delay. The instrument includes memory to store up to four complete instrument setups. The operator may use the front panel or the computer interface to store a complete “snapshot” of all key instrument settings, and recall this setup at a later time.

This instrument is intended for use in research, development, test and calibration laboratories by qualified personnel.

SPECIFICATIONS

Model:	AVR-DV1-B	AVR-DV1-B-FTR
Amplitude:	< 25 to 1000 Volts (into an open circuit)	
Output impedance:	50 Ohms (at mainframe output)	
Minimum and maximum rise & fall times (1%-63.2% measured with no DUT installed in the test jig), with corresponding dV/dt rates ² :	$T_{MIN} = \leq 125$ ns at 400V (2.02 kV/us at 400V) $T_{MIN} = \leq 125$ ns at 600V (3.03 kV/us at 600V) $T_{MIN} = \leq 125$ ns at 800V (4.04 kV/us at 800V) $T_{MIN} = \leq 125$ ns at 1000V (5.06 kV/us at 1000V)	$T_{MIN} = \leq 16.8$ ns at 400V (15.0 kV/us at 400V) $T_{MIN} = \leq 19$ ns at 600V (20.0 kV/us at 600V) $T_{MIN} = \leq 22$ ns at 800V (23.0 kV/us at 800V) $T_{MIN} = \leq 25$ ns at 1000V (25.3 kV/us at 1000V)
	$T_{MAX} \geq 1.1$ us at 400V (0.23 kV/us at 400V) $T_{MAX} \geq 1.1$ us at 600V (0.34 kV/us at 600V) $T_{MAX} \geq 1.1$ us at 800V (0.46 kV/us at 800V) $T_{MAX} \geq 1.1$ us at 1000V (0.57 kV/us at 1000V)	
Pulse width (FWHM) ¹ :	200 ns to 200 us	
Maximum PRF:	1 kHz	
Duty cycle (max):	0.02%	
Max. droop at max. pulse width:	6%	
Polarity:	+ or -, switchable	
GPiB and RS-232 control ¹ :	Standard on -B units. See http://www.avtechpulse.com/gpib for more information.	
LabView Drivers:	Available at http://www.avtechpulse.com/labview . Note that "T" can not be remotely adjusted. It is adjusted using a one-turn mechanical potentiometer (and a two-position range switch for units with the -FTR option).	
Ethernet port, for remote control using VXI-11.3, ssh, telnet, & web:	Included. Recommended as a modern alternative to GPiB / RS-232. See http://www.avtechpulse.com/options/vxi for details.	
Settings resolution ⁴ :	The resolution of the timing parameters (pulse width, delay, period) varies, but is always better than 0.15% of (set value + 20 ns). The amplitude resolution is < 0.1% of the maximum amplitude.	
Settings accuracy ⁴ :	Typically $\pm 3\%$ (plus $\pm 1V$ or ± 2 ns) after 10 minute warmup. For high-accuracy applications requiring traceable calibration, verify the output parameters with a calibrated oscilloscope ³ .	
Propagation delay:	≤ 200 ns (Ext trig in to pulse out)	
Jitter (Ext trig in to pulse out):	± 100 ps $\pm 0.03\%$ of sync delay	
Trigger modes:	Internal trigger, external trigger (TTL level pulse, > 10 ns, 1 k Ω input impedance), front-panel "Single Pulse" pushbutton, or single pulse trigger via computer command. In the external trigger mode, the pulse width may be set by the instrument, or it may be set to track the input pulse width.	
Variable delay:	Sync to main out: 0 to 1.0 seconds, for all trigger modes (including external trigger).	
Sync output:	> +3 Volts, > 50 ns, will drive 50 Ohm loads	
Gated operation:	Synchronous or asynchronous, active high or low, switchable. Suppresses triggering when active.	
Connectors, Mainframe:	OUT: SHV. Trig, Sync, Gate: BNC	
Test jig:	The test jig connects to the mainframe with a coaxial cable and a DB9 control cable (both are included). The test jig has a hinged lid. The mainframe output is disabled when the load is open. Tests must be performed with the lid closed. The jig contains a ZIF socket suitable for a 6-pin DIP package (Anode = pin 1, Cathode = pin 2, Out = pin 6, Ground = pin 4, NC = pins 3 and 5). The clearance above the socket is > 2.5 cm (to accommodate package adapters).	
Power requirements:	100 - 240 Volts, 50 - 60 Hz	
Dimensions (H x W x D):	100 mm x 430 mm x 375 mm (3.9" x 17" x 14.8")	
Chassis material:	cast aluminum frame and handles, blue vinyl on aluminum cover plates	
Temperature range:	$+5^{\circ}C$ to $+40^{\circ}C$	

- 1) The output pulse width may also be controlled externally by applying a TTL-level trigger of the desired width to a rear-panel BNC connector ($PW_{IN} = PW_{OUT}$).
- 2) Using the formula $dV/dt = 0.632 V / T$, where V is the voltage amplitude, and T is the 1%-63.2% rise time.
- 3) These instruments are provided with a basic calibration checksheet, showing a selection of measured output parameters. These measurements are performed with equipment that is calibrated on a regular basis by a third-party ISO/IEC 17025:2005 accredited calibration laboratory. However, Avtech itself does not claim any accreditation. For applications requiring traceable performance, use a calibrated measurement system rather than relying on the accuracy of the pulse generator settings.
- 4) The rise time "T" is controlled by uncalibrated mechanical controls. For applications requiring traceable performance, use a calibrated measurement system.

REGULATORY NOTES

FCC PART 18

This device complies with part 18 of the FCC rules for non-consumer industrial, scientific and medical (ISM) equipment.

This instrument is enclosed in a rugged metal chassis and uses a filtered power entry module (where applicable). The main output signal is provided on a shielded connector that is intended to be used with shielded coaxial cabling and a shielded load. Under these conditions, the interference potential of this instrument is low.

If interference is observed, check that appropriate well-shielded cabling is used on the output connectors. Contact Avtech (info@avtechpulse.com) for advice if you are unsure of the most appropriate cabling. Also, check that your load is adequately shielded. It may be necessary to enclose the load in a metal enclosure.

If any of the connectors on the instrument are unused, they should be covered with shielded metal "dust caps" to reduce the interference potential.

This instrument does not normally require regular maintenance to minimize interference potential. However, if loose hardware or connectors are noted, they should be tightened. Contact Avtech (info@avtechpulse.com) if you require assistance.

EC DECLARATION OF CONFORMITY



We Avtech Electrosystems Ltd.
 P.O. Box 5120, LCD Merivale
 Ottawa, Ontario
 Canada K2C 3H5

declare that this pulse generator meets the intent of Directive 2004/108/EG for Electromagnetic Compatibility. Compliance pertains to the following specifications as listed in the official Journal of the European Communities:

EN 50081-1 Emission

EN 50082-1 Immunity

and that this pulse generator meets the intent of the Low Voltage Directive 2006/95/EC. Compliance pertains to the following specifications as listed in the official Journal of the European Communities:

EN 61010-1:2001 Safety requirements for electrical equipment for measurement, control, and laboratory use

DIRECTIVE 2011/65/EU (RoHS)

We Avtech Electrosystems Ltd.
P.O. Box 5120, LCD Merivale
Ottawa, Ontario
Canada K2C 3H5

declare that, to the best of our knowledge, all electrical and electronic equipment (EEE) sold by the company are in compliance with Directive 2011/65/EU of the European Parliament and of the Council of 8 June 2011 on the restriction of the use of certain hazardous substances in electrical and electronic equipment (also known as “RoHS Recast”). In addition, this declaration of conformity is issued under the sole responsibility of Avtech Electrosystems Ltd. Specifically, products manufactured do not contain the substances listed in the table below in concentrations greater than the listed maximum value.

<i>Material/Substance</i>	<i>Threshold level</i>
Lead (Pb)	< 1000 ppm (0.1% by mass)
Mercury (Hg)	< 1000 ppm (0.1% by mass)
Hexavalent Chromium (Cr6+)	< 1000 ppm (0.1% by mass)
Polybrominated Biphenyls (PBB)	< 1000 ppm (0.1% by mass)
Polybrominated Diphenyl ethers (PBDE)	< 1000 ppm (0.1% by mass)
Cadmium (Cd)	< 100 ppm (0.01% by mass)
Bis(2-ethylhexyl) phthalate (DEHP)	< 1000 ppm (0.1% by mass)
Butyl benzyl phthalate (BBP)	< 1000 ppm (0.1% by mass)
Dibutyl phthalate (DBP)	< 1000 ppm (0.1% by mass)
Diisobutyl phthalate (DIBP)	< 1000 ppm (0.1% by mass)

DIRECTIVE 2002/96/EC (WEEE)

European customers who have purchased this equipment directly from Avtech will have completed a “WEEE Responsibility Agreement” form, accepting responsibility for WEEE compliance (as mandated in Directive 2002/96/EC of the European Union and local

laws) on behalf of the customer, as provided for under Article 9 of Directive 2002/96/EC.

Customers who have purchased Avtech equipment through local representatives should consult with the representative to determine who has responsibility for WEEE compliance. Normally, such responsibilities will lie with the representative, unless other arrangements (under Article 9) have been made.

Requirements for WEEE compliance may include registration of products with local governments, reporting of recycling activities to local governments, and financing of recycling activities.



FIRMWARE LICENSING

Instruments with firmware versions 5.00 or higher use open-source software internally. Some of this software requires that the source code be made available to the user as a condition of its licensing. This source code is available upon request (contact info@avtechpulse.com).

Earlier firmware versions do not contain any open source software.

INSTALLATION

VISUAL CHECK

After unpacking the instrument, examine to ensure that it has not been damaged in shipment. Visually inspect all connectors, knobs, liquid crystal displays (LCDs), and the handles. If the instrument has been damaged, file a claim immediately with the company that transported the instrument.

The following items should be with the instrument:

- 1) A power cord.
- 2) A GPIB cable
- 3) Two instrumentation manuals (this manual and the “Programming Manual for -B Instruments”).
- 4) One AVX-DVDT-EVC test jig, with a hinged lid.
- 5) A 2 meter length of SHV-to-SHV cable.
- 6) A 2 meter DB-9 control cable.

POWER RATINGS

This instrument is intended to operate from 100 - 240 V, 50 - 60 Hz.

The maximum power consumption is 57 Watts. Please see the “FUSES” section for information about the appropriate AC and DC fuses.

This instrument is an “Installation Category II” instrument, intended for operation from a normal single-phase supply.

CONNECTION TO THE POWER SUPPLY

An IEC-320 three-pronged recessed male socket is provided on the back panel for AC power connection to the instrument. One end of the detachable power cord that is supplied with the instrument plugs into this socket. The other end of the detachable power cord plugs into the local mains supply. Use only the cable supplied with the instrument. The mains supply must be earthed, and the cord used to connect the instrument to the mains supply must provide an earth connection. (The supplied cord does this.)

 Warning: Failure to use a grounded outlet may result in injury or death due to electric shock. This product uses a power cord with a ground connection. It must be connected to a properly grounded outlet. The instrument chassis is connected to the ground wire in the power cord.

The table below describes the power cord that is normally supplied with this instrument, depending on the destination region:

Destination Region	Description	Option	Manufacturer	Part Number
United Kingdom, Hong Kong, Singapore, Malaysia	BS 1363, 230V, 50 Hz	-AC00	Qualtek	370001-E01
Australia, New Zealand	AS 3112:2000, 230-240V, 50 Hz	-AC01	Qualtek	374003-A01
Continental Europe, Korea, Indonesia, Russia	European CEE 7/7 "Schuko" 230V, 50 Hz	-AC02	Qualtek	364002-D01
North America, Taiwan	NEMA 5-15, 120V, 60 Hz	-AC03	Qualtek	312007-01
Switzerland	SEV 1011, 230V, 50 Hz	-AC06	Qualtek	378001-E01
South Africa, India	SABS 164-1, 220-250V, 50 Hz	-AC17	Volex	2131H 10 C3
Japan	JIS 8303, 100V, 50-60 Hz	-AC18	Qualtek	397002-01
Israel	SI 32, 220V, 50 Hz	-AC19	Qualtek	398001-01
China	GB 1002-1 / 2099-1, 220V, 50 Hz	-AC22	Qualtek	399012-01

PROTECTION FROM ELECTRIC SHOCK

 Operators of this instrument must be protected from electric shock at all times. The owner must ensure that operators are prevented access and/or are insulated from every connection point. In some cases, connections must be exposed to potential human contact. Operators must be trained to protect themselves from the risk of electric shock. This instrument is intended for use by qualified personnel who recognize shock hazards and are familiar with safety precautions required to avoid possibly injury. In particular, operators should:

1. Keep exposed high-voltage wiring to an absolute minimum.
2. Wherever possible, use shielded connectors and cabling.
3. Connect and disconnect loads and cables only when the instrument is turned off.
4. Keep in mind that all cables, connectors, oscilloscope probes, and loads must have an appropriate voltage rating.
5. Do not attempt any repairs on the instrument, beyond the fuse replacement procedures described in this manual. Contact Avtech technical support (see

page 2 for contact information) if the instrument requires servicing. Service is to be performed solely by qualified service personnel.

ENVIRONMENTAL CONDITIONS

This instrument is intended for use under the following conditions:

1. indoor use;
2. altitude up to 2 000 m;
3. temperature 5 °C to 40 °C;
4. maximum relative humidity 80 % for temperatures up to 31 °C decreasing linearly to 50 % relative humidity at 40 °C;
5. Mains supply voltage fluctuations up to ± 10 % of the nominal voltage;
6. no pollution or only dry, non-conductive pollution.

LABVIEW DRIVERS

A LabVIEW driver for this instrument is available for download on the Avtech web site, at <http://www.avtechpulse.com/labview>. A copy is also available in National Instruments' Instrument Driver Library at <http://www.natinst.com/>.

FUSES

This instrument contains four fuses. All are accessible from the rear-panel. Two protect the AC prime power input, and two protect the internal DC power supplies. The locations of the fuses on the rear panel are shown in the figure below:



AC FUSE REPLACEMENT

To physically access the AC fuses, the power cord must be detached from the rear panel of the instrument. The fuse drawer may then be extracted using a small flat-head screwdriver, as shown below:



DC FUSE REPLACEMENT

The DC fuses may be replaced by inserting the tip of a flat-head screwdriver into the fuse holder slot, and rotating the slot counter-clockwise. The fuse and its carrier will then pop out.

FUSE RATINGS

The following table lists the required fuses:

Fuses	Nominal Mains Voltage	Rating	Case Size	Recommended Replacement Part	
				Littelfuse Part Number	Digi-Key Stock Number
#1, #2 (AC)	100-240V	0.5A, 250V, Time-Delay	5×20 mm	0218.500HXP	F2416-ND
#3 (DC)	N/A	1.0A, 250V, Time-Delay	5×20 mm	0218001.HXP	F2419-ND
#4 (DC)	N/A	1.0A, 250V, Time-Delay	5×20 mm	0218001.HXP	F2419-ND

The recommended fuse manufacturer is Littelfuse (<http://www.littelfuse.com>).

Replacement fuses may be easily obtained from Digi-Key (<http://www.digikey.com>) and other distributors.

FRONT PANEL CONTROLS

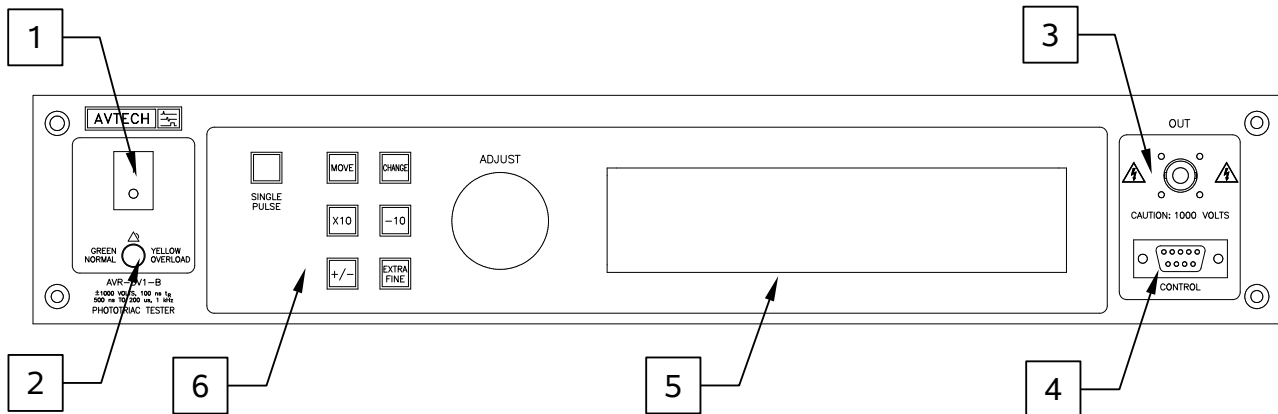

1. **POWER Switch**. This is the main power switch. When turning the instrument on, there is normally a delay of 10 seconds before anything is shown on the main display, as the internal operating system boots up.

If the main menu does not appear after 30 seconds, turn off the instrument and leave it off for at least 60 seconds before applying power again.

2. **OVERLOAD Indicator**. When the instrument is powered, this indicator is normally green, indicating normal operation. If this indicator is yellow, an internal automatic overload protection circuit has been tripped. If the unit is overloaded (by operating at an exceedingly high duty cycle or by operating into a very low impedance), the protective circuit will disable the output of the instrument and turn the indicator light yellow. The light will stay yellow (i.e. output disabled) for about 5 seconds after which the instrument will attempt to re-enable the output (i.e. light green) for about 1 second. If the overload condition persists, the output will be disabled again (i.e. light yellow) for another 5 seconds. If the overload condition has been removed, the instrument will resume normal operation.

This overload indicator may flash yellow briefly at start-up. This is not a cause for concern.

3. **PULSE OUT CONNECTOR**. This SHV connector provides the pulse output signal to the test jig. This output should be connected to the corresponding input on the test jig using the supplied SHV-to-SHV coaxial cable.

 **Caution:** Voltages as high as 1 kV may be present on the center conductor of this output connector. Avoid touching this conductor. Connect to this connector using standard coaxial cable, to ensure that the center conductor is not exposed.

4. **CONTROL Connector**. This DB-9 female connector should be connected to the corresponding connector on the test jig using the supplied DB-9 cable. This cable

contains the safety interlock signals that ensure that the test jig lid is closed. The pinout is as follows:

Pin 1 - To test jig switch 1.

Pin 2 - To test jig switch 2.

Pin 5 - Ground.

Pin 6 - To test jig switch 1.

Pin 7 - To test jig switch 2.

Pin 9 - Safety sensor power supply (+15V through 680 Ohms).

When the test jig lid is safely closed, Pin 1 is shorted to Pin 6, and Pin 2 is shorted to Pin 7.

5. LIQUID CRYSTAL DISPLAY (LCD). This LCD is used in conjunction with the keypad to change the instrument settings. Normally, the main menu is displayed, which lists the key adjustable parameters and their current values. The "Programming Manual for -B Instruments" describes the menus and submenus in detail.
6. KEYPAD.

Control Name	Function
MOVE	This moves the arrow pointer on the display.
CHANGE	This is used to enter the submenu, or to select the operating mode, pointed to by the arrow pointer.
×10	If one of the adjustable numeric parameters is displayed, this increases the setting by a factor of ten.
÷10	If one of the adjustable numeric parameters is displayed, this decreases the setting by a factor of ten.
+/-	If one of the adjustable numeric parameters is displayed, and this parameter can be both positive or negative, this changes the sign of the parameter.
EXTRA FINE	This changes the step size of the ADJUST knob. In the extra-fine mode, the step size is twenty times finer than in the normal mode. This button switches between the two step sizes.
ADJUST	This large knob adjusts the value of any displayed numeric adjustable values, such as frequency, pulse width, etc. The adjust step size is set by the "EXTRA FINE" button. When the main menu is displayed, this knob can be used to move the arrow pointer.

REAR PANEL CONTROLS

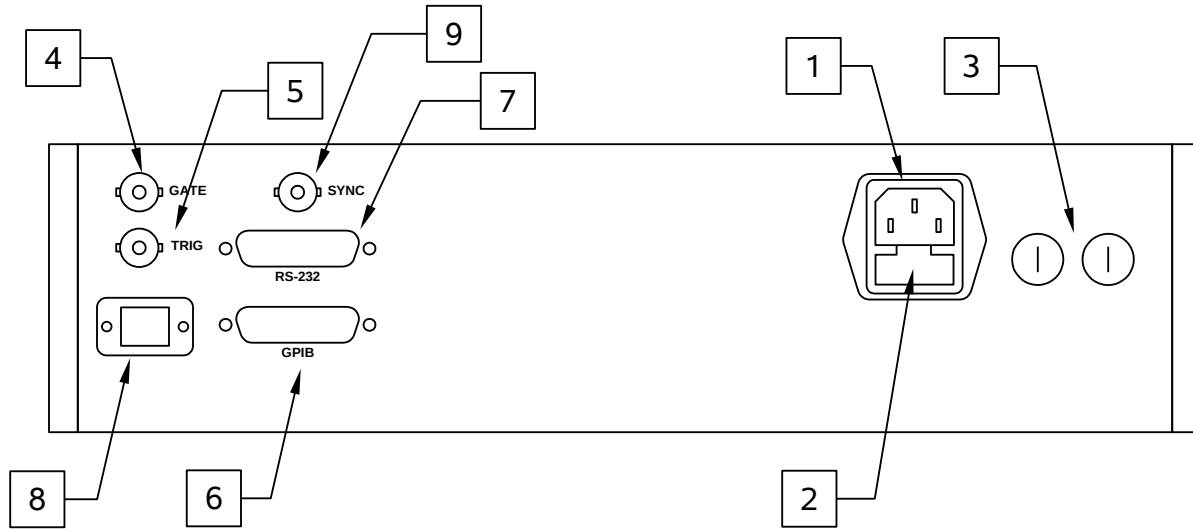

Note: some connectors may be in different positions than shown above, depending on the exact combination of options ordered.

1. AC POWER INPUT. An IEC-320 C14 three-pronged recessed male socket is provided on the back panel for AC power connection to the instrument. One end of the detachable power cord that is supplied with the instrument plugs into this socket.
2. AC FUSE DRAWER. The two fuses that protect the AC input are located in this drawer. Please see the “FUSES” section of this manual for more information.
3. DC FUSES. These two fuses protect the internal DC power supplies. Please see the “FUSES” sections of this manual for more information.
4. GATE. This TTL-level (0 and +5V) logic input can be used to gate the triggering of the instrument. This input can be either active high or active low, depending on the front panel settings or programming commands. (The instrument triggers normally when this input is unconnected). When set to active high mode, this input is pulled-down to ground by a 1 k Ω resistor. When set to active low mode, this input is pulled-up to +5V by a 1 k Ω resistor.
5. TRIG. This TTL-level (0 and +5V) logic input can be used to trigger the instrument, if the instrument is set to triggering externally. The instrument triggers on the rising edge of this input. The input impedance of this input is 1 k Ω . (Depending on the length of cable attached to this input, and the source driving it, it may be desirable to add a coaxial 50 Ohm terminator to this input to provide a proper transmission line termination. The Pasternack (www.pasternack.com) PE6008-50 BNC feed-thru 50 Ohm terminator is suggested for this purpose.)

When triggering externally, the instrument can be set such that the output pulse

width tracks the pulse width on this input, or the output pulse width can be set independently.

6. GPIB Connector. A standard GPIB cable can be attached to this connector to allow the instrument to be computer-controlled. See the “Programming Manual for -B Instruments” for more details on GPIB control.
7. RS-232 Connector. A standard serial cable with a 25-pin male connector can be attached to this connector to allow the instrument to be computer-controlled. A user name (“admin”) and a password (“default”, as shipped from the factory) are required when logging into a serial terminal session. The internal controller attempts to auto-sense the parity setting. It may be necessary to send a few return characters before attempting a login in order to provide enough data to allow this auto-sensing to work. (A standard Linux “agetty” process is used to implement serial control internally.) See the “Programming Manual for -B Instruments” for more details on RS-232 control.
8. Network Connector. This Ethernet connector allows the instrument to be remotely controlled using the VXI-11.3, ssh (secure shell), telnet, and http (web) protocols. See the “Programming Manual for -B Instruments” for more details.
9. SYNC OUT. This connector supplies a SYNC output that can be used to trigger other equipment, particularly oscilloscopes. This signal leads (or lags) the main output by a duration set by the “DELAY” controls and has an approximate amplitude of +3 Volts to $R_L > 50\Omega$ with a pulse width of approximately 100 ns.

TIMING CONTROL

BASIC PULSE CONTROL

The mainframe can be triggered by its own internal clock or by an external TTL trigger signal. In either case, two output channels respond to the trigger: OUT and SYNC. The OUT channel is the signal that is applied to the load. Its amplitude and pulse width are variable. The SYNC pulse is a fixed-width TTL-level reference pulse used to trigger oscilloscopes or other measurement systems. When the delay is set to a positive value the SYNC pulse precedes the OUT pulse. When the delay is set to a negative value the SYNC pulse follows the OUT pulse.

These pulses are illustrated below, assuming internal triggering and a positive delay:

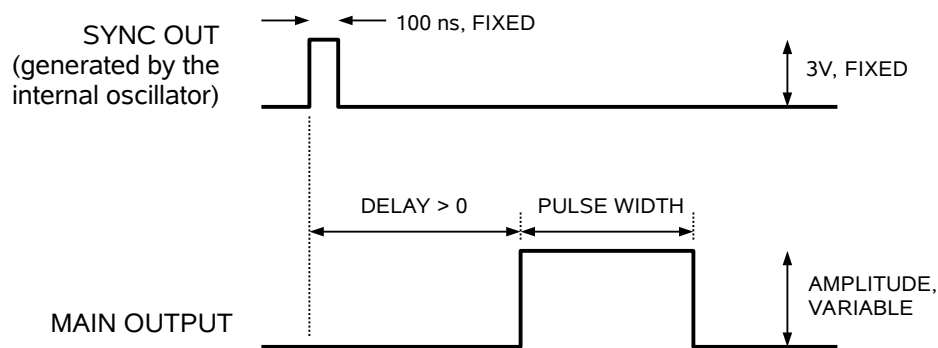

Figure A

If the delay is negative, the order of the SYNC and OUT pulses is reversed:



Figure B

The next figure illustrates the relationship between the signal when an external TTL-level trigger is used:

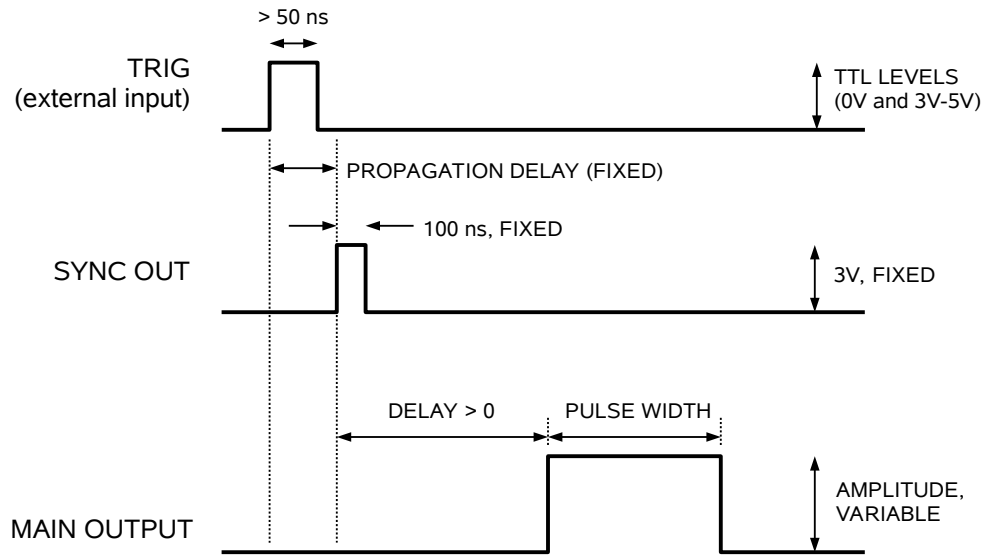

Figure C

As before, if the delay is negative, the order of the SYNC and OUT pulses is reversed.

The last figure illustrates the relationship between the signal when an external TTL-level trigger is used in the $PW_{IN}=PW_{OUT}$ mode. In this case, the output pulse width equals the external trigger's pulse width (approximately), and the delay circuit is bypassed:

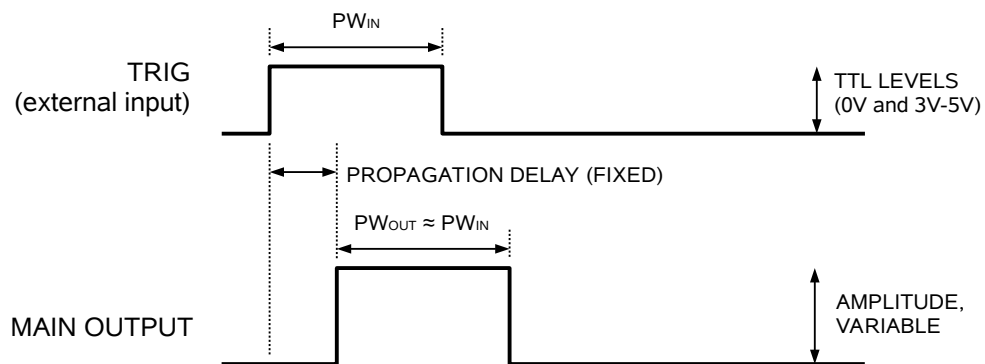

Figure D

The delay, pulse width, and frequency (when in the internal mode), of the OUT pulse can be varied with front panel controls or via the GPIB or RS-232 computer interfaces.

TRIGGER MODES

This instrument has four trigger modes:

- Internal Trigger: the instrument controls the trigger frequency, and generates the clock internally.
- External Trigger: the instrument is triggered by an external TTL-level clock on the back-panel TRIG connector.
- Manual Trigger: the instrument is triggered by the front-panel “SINGLE PULSE” pushbutton.
- Hold Trigger: the instrument is set to not trigger at all.

These modes can be selected using the front panel trigger menu, or by using the appropriate programming commands. (See the “Programming Manual for -B Instruments” for more details.)

PULSE WIDTH MODES

This instrument has two pulse width modes:

- Normal: the instrument controls the output pulse width.
- $PW_{IN}=PW_{OUT}$: the output pulse width equals the pulse width of the trigger signal on the “TRIG” connector. The instrument must be in the external trigger mode.

These modes can be selected using the front panel pulse width menu, or by using the appropriate programming commands. (See the “Programming Manual for -B Instruments” for more details.)

GATING MODES

Triggering can be suppressed by a TTL-level signal on the rear-panel GATE connector. The instrument can be set to stop triggering when this input high or low, using the front-panel gate menu or the appropriate programming commands. This input can also be set to act synchronously or asynchronously. When set to asynchronous mode, the GATE will disable the output immediately. Output pulses may be truncated. When set to synchronous mode, the output will complete the full pulse width if the output is high, and then stop triggering. No pulses are truncated in this mode.

USING THE TEST JIG

The basic test arrangement for the AVR-DV1-B is shown in the figure below. The OUT output on the instrument mainframe is connected to the IN input on the test jig using the supplied SHV-to-SHV coaxial cable, and the control cable is connected using the supplied DB-9 cable.

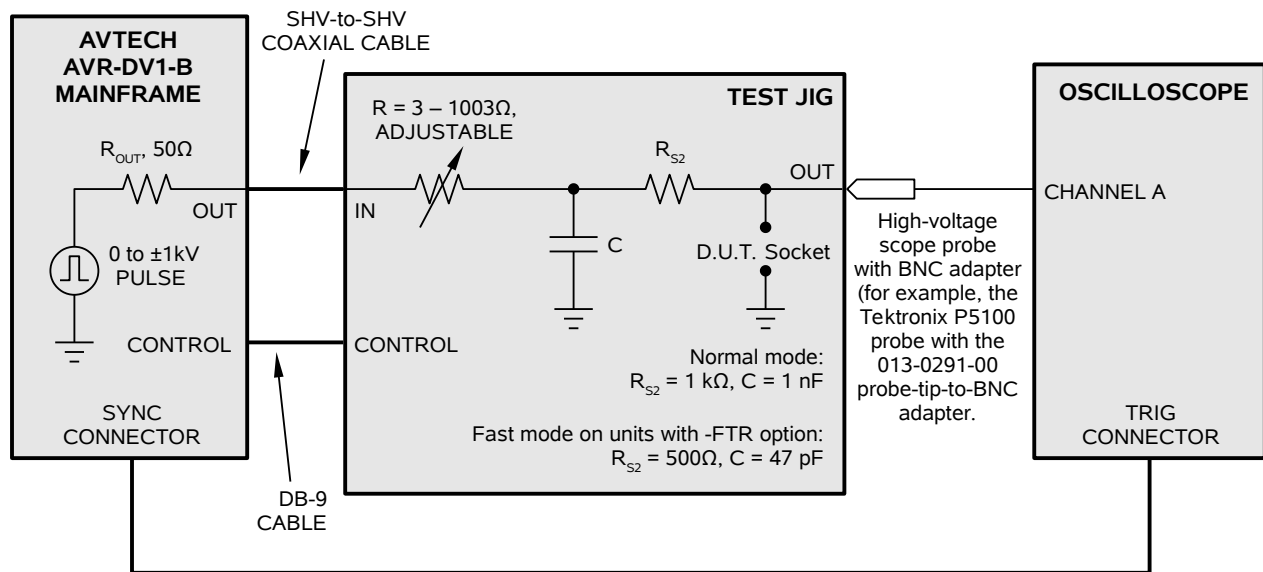

The device-under-test (DUT) is installed in a ZIF socket in the test jig. Access to the voltage across the DUT is provided on the test jig OUT BNC connector. A high-voltage oscilloscope probe, preferably with a BNC adapter, must be used to observe this waveform.

⚠ Do not connect the test jig OUT signal directly to an oscilloscope. The voltage at this point may be as high as ± 1 kV, which will destroy unprotected oscilloscope inputs.

⚡ Caution: Voltages as high as 1 kV may be present on the center conductor of this output connector. Avoid touching this conductor. Connect to this connector using standard coaxial cables or adapters, to ensure that the center conductor is never exposed.

ADJUSTING "T"

When observing the DUT voltage waveform, the user usually measures the rise time of the pulse between 1% and 63.2% of full-scale (T). The value of "T" is varied using the adjustable resistance (R) in the test jig.

Units with the -FTR option have a two-position FAST/SLOW switch on the test jig, which controls the value of the capacitance C. In the fast mode, it is 47 pF. In the slow

mode, it is 1 nF. (In the fast mode, the value of R_{S2} is also reduced by a factor of 2, to obtain the fastest possible switching speeds).

If the amplitude is set to V, dV/dt is usually calculated as:

$$dV/dt = 0.632 V / T$$

The dV/dt rates that can be obtained at 400, 600, 800, and 1000V are summarized below:

	Standard units	Units with -FTR option
Fastest	$T_{MIN} = \leq 125$ ns at 400V (2.02 kV/us at 400V) $T_{MIN} = \leq 125$ ns at 600V (3.03 kV/us at 600V) $T_{MIN} = \leq 125$ ns at 800V (4.04 kV/us at 800V) $T_{MIN} = \leq 125$ ns at 1000V (5.06 kV/us at 1000V)	$T_{MIN} = \leq 16.8$ ns at 400V (15.0 kV/us at 400V) $T_{MIN} = \leq 19$ ns at 600V (20.0 kV/us at 600V) $T_{MIN} = \leq 22$ ns at 800V (23.0 kV/us at 800V) $T_{MIN} = \leq 25$ ns at 1000V (25.3 kV/us at 1000V)
Slowest	$T_{MAX} \geq 1.1$ us at 400V (0.23 kV/us at 400V) $T_{MAX} \geq 1.1$ us at 600V (0.34 kV/us at 600V) $T_{MAX} \geq 1.1$ us at 800V (0.46 kV/us at 800V) $T_{MAX} \geq 1.1$ us at 1000V (0.57 kV/us at 1000V)	

ACCESSIBLE VOLTAGES

The mainframe provides pulsed voltages of up to 1 kV to the test jig. For this reason, the output is automatically disabled when the test jig lid is open. The lid must be closed to obtain measurements.

 Shielded cabling and/or adapters should be used for all connections to the "IN" and "OUT" terminals on the test jig, and the "OUT" connector on the mainframe.

TEST JIG MECHANICAL ASPECTS

AVX-DVDT-EVC TEST JIG

One AVX-DVDT-EVC test jig is supplied with the AVR-DV1-B mainframe. The ZIF (Zero Insertion Force) socket on the AVX-DVDT-EVC test jig accepts 6 pin DIP devices.

Pins 1-3 of the DUT are unconnected. These are normally the LED pins.

Pin 4 is connected to ground.

The test signal is applied to pin 6 of the DUT.

The ZIF socket itself actually has 14 pins, but only 6 of them are used. The correct positions are clearly marked on the circuit board silkscreening. A photo of the arrangement is shown below:

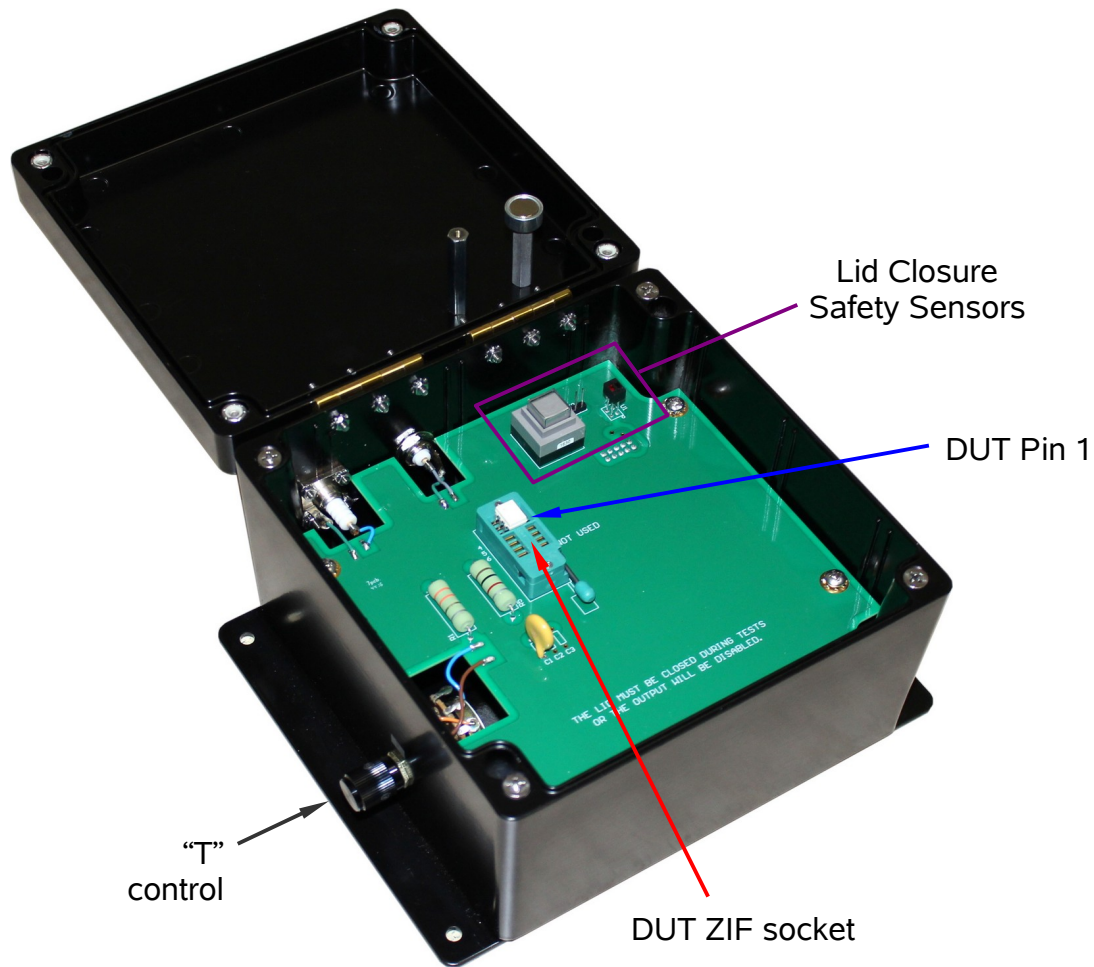

The above photo also shows the location of the “T” control. This adjust the variable resistance “R”, thus controlling the rise and fall times. In other words, it controls the “dt” portion of the key dV/dt ratio.

Units with the -FTR option have a two-position FAST/SLOW switch on the test jig above the “T” control, which allows the capacitance C to be reduced to a lower value (to obtain faster dV/dt rates).

The IN, OUT, and CONTROL connectors are on the rear of the jig, below the hinges:



TYPICAL RESULTS

WITH NO DUT

The following waveform shows the voltage across the DUT ZIF socket with no DUT installed, with 10 Hz PRF, 10 us pulse width, +400V amplitude, and the “T” control set fully counter-clockwise (for the fastest rise time):

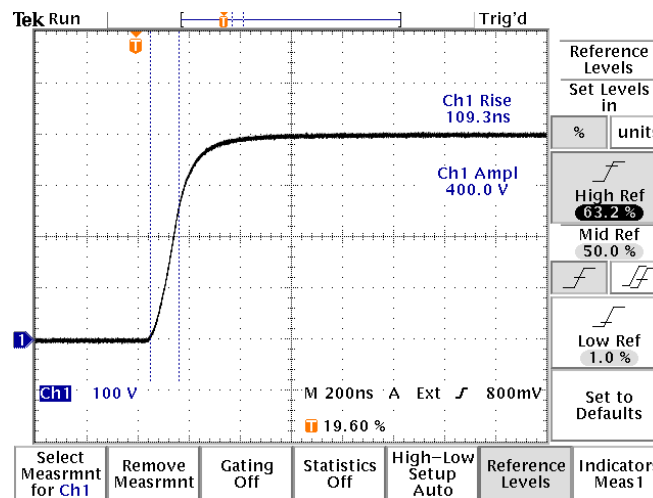

In this scenario, the 1%-63.2% rise time is 109.3 ns. If V is the set amplitude, and T is the 63.2% rise time, the dV/dt can be estimated as $0.632 \text{ V} / T \approx 2300 \text{ V/us}$.

If the amplitude is boosted to +1 kV, and the T control is rotated fully-clockwise (for the slowest rise time), this waveform is obtained:

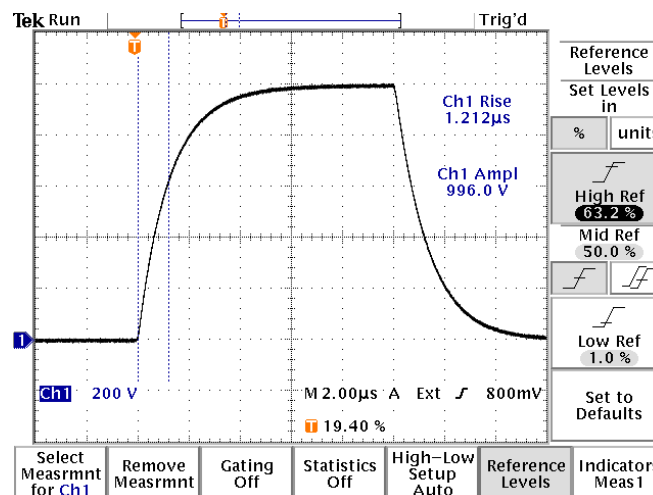

In this scenario, the dV/dt ratio is approximately 520 V/us.

TYPICAL RESULTS – FAIRCHILD MOC3052M

The Fairchild MOC3052M is a 600V random-phase phototriac. According to its datasheet, $dV/dt \geq 1000 \text{ V/us}$, when measured at 400V.

To confirm this, a MOC3052M was installed in the test jig, and the mainframe was set to operate at 10 Hz, 10 us pulse width, and +400V amplitude. As the “T” dial on the test jig was varied, the following waveforms were obtained:

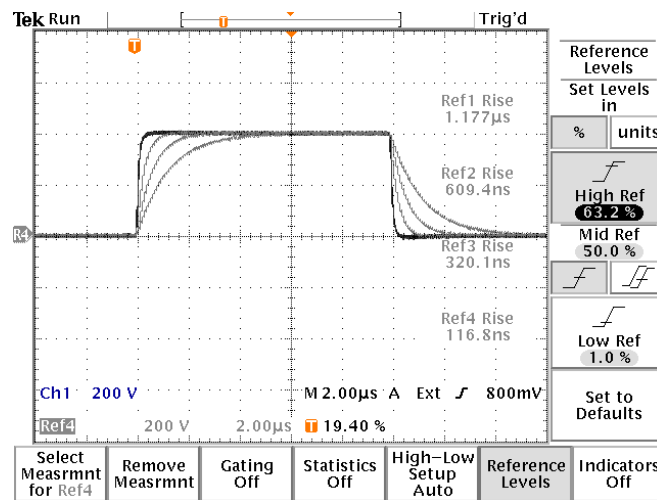

The above photo shows +400V DUT pulses with four different values of T. With the “T” control set to minimum, $T = 116.8 \text{ ns}$, corresponding to:

$$dV/dt = 0.632 \times 400\text{V} / 116.8 \text{ ns} = 2164 \text{ V/us}$$

Thus, at 400V, the MOC3052M easily meets its 1000 V/us specification. However, if the amplitude is increased to the maximum rating of 600V, the results are different:

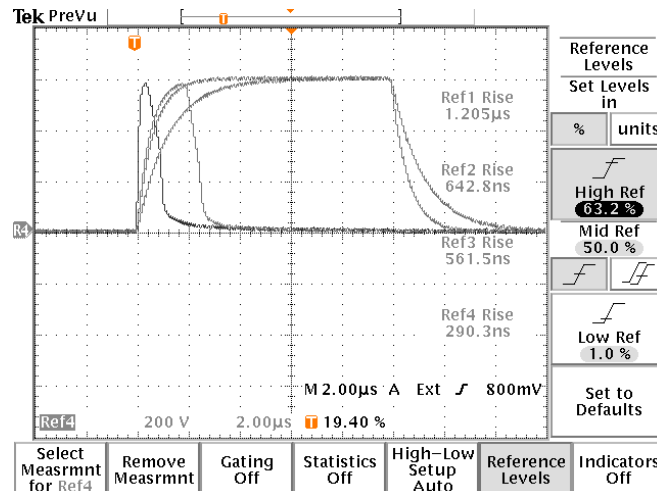

In this case, the lowest value of “T” that results in correct operation is 642.8 ns, approximately, giving:

$$dV/dt = 0.632 \times 600V / 642.8 \text{ ns} = 590 \text{ V/us}$$

The datasheet does not specify a dV/dt rating at 600V, only 400V. However, it is interesting to note that the measured dV/dt limit is much lower at 600V than at 400V.

TYPICAL RESULTS – FAIRCHILD MOC3062M

The Fairchild MOC3062M is a 600V zero-cross phototriac. According to its datasheet, $dV/dt \geq 600 \text{ V/us}$, typically 1500 V/us. The test voltage is not specified.

To confirm this, a MOC3062M was installed in the test jig, and the mainframe was set to operate at 10 Hz, 10 us pulse width, and +200V amplitude. As the “T” dial on the test jig was varied, the following waveforms were obtained:

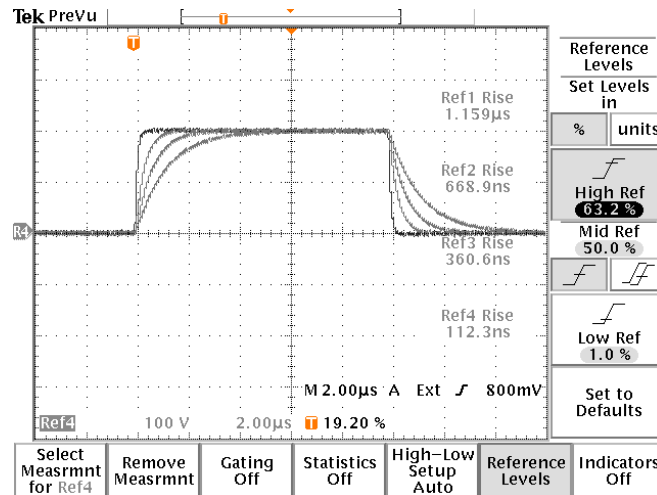

The above photo shows +200V DUT pulses with four different values of T. With the “T” control set to minimum, T = 112.3 ns, corresponding to:

$$dV/dt = 0.632 \times 200V / 112.3 \text{ ns} = 1126 \text{ V/us}$$

Thus, at 200V, the MOC3062M easily meets its 600 V/us specification. However, if the amplitude is increased to 400V, the results are different:

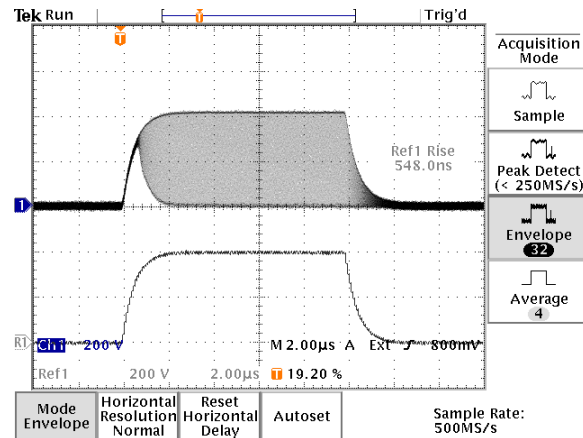
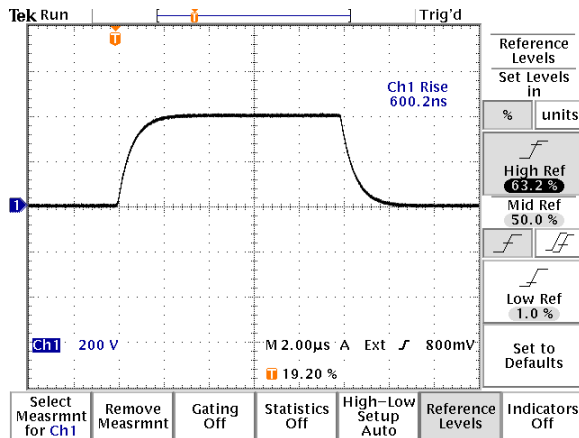

In this case, the lowest value of “T” that results in correct operation is 600.2 ns (see the left-side photo), approximately, giving:

$$dV/dt = 0.632 \times 400V / 600.2 \text{ ns} = 421 \text{ V/us}$$

As T is decreased, the voltage starts to collapse – see the right-side photo above. The device does not meet $dV/dt > 600 \text{ V/us}$ at 400V. The results are worse at 600V, the rated maximum:

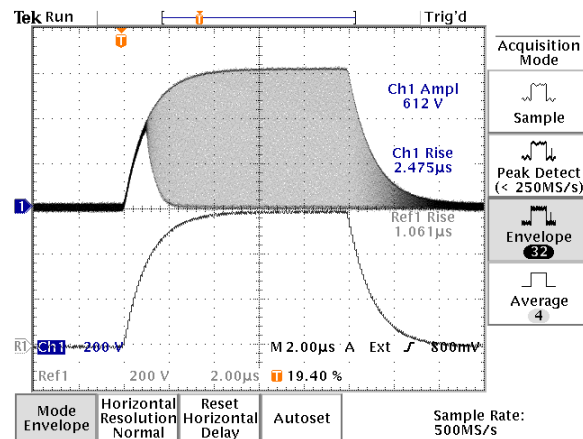
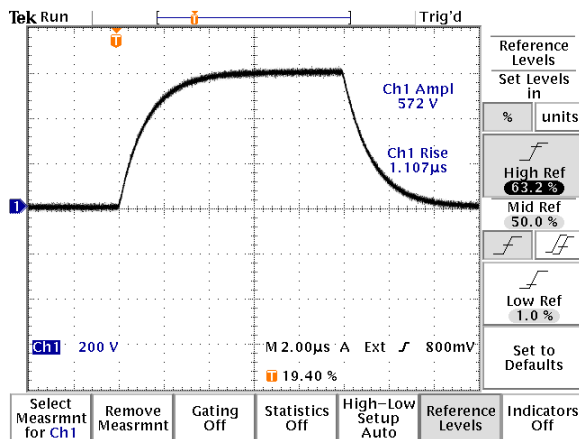

The device is stable at $T = 1.107 \text{ us}$, but collapses at $T = 1.061 \text{ us}$. At 600V, this gives:

$$dV/dt = 0.632 \times 600V / 1.107 \text{ us} = 342 \text{ V/us}$$

COMMENTS

The above results show that when generating dV/dt specifications for phototriacs, the test voltage should always be specified. The maximum dV/dt rating is strongly dependent on V.

PROGRAMMING YOUR PULSE GENERATOR

KEY PROGRAMMING COMMANDS

The “Programming Manual for -B Instruments” describes in detail how to connect the pulse generator to your computer, and the programming commands themselves. A large number of commands are available; however, normally you will only need a few of these. Here is a basic sample sequence of commands that might be sent to the instrument after power-up:

*rst	(resets the instrument)
trigger:source internal	(selects internal triggering)
frequency 1000 Hz	(sets the frequency to 1000 Hz)
pulse:width 1 us	(sets the pulse width to 1 us)
pulse:delay 2 us	(sets the delay to 2 us)
volt 200	(sets the amplitude to 200 V)
output on	(turns on the output)

For triggering a single event, this sequence would be more appropriate:

*rst	(resets the instrument)
trigger:source hold	(turns off all triggering)
pulse:width 1 us	(sets the pulse width to 1 us)
pulse:delay 2 us	(sets the delay to 2 us)
output on	(turns on the output)
volt 200	(sets the amplitude to 200 V)
trigger:source immediate	(generates a single non-repetitive trigger event)
trigger:source hold	(turns off all triggering)
output off	(turns off the output)

To set the instrument to trigger from an external TTL signal applied to the rear-panel TRIG connector, use:

*rst	(resets the instrument)
trigger:source external	(selects internal triggering)
pulse:width 1 us	(sets the pulse width to 1 us)
pulse:delay 2 us	(sets the delay to 2 us)
volt 200	(sets the amplitude to 200 V)
output on	(turns on the output)

These commands will satisfy 90% of your programming needs.

ALL PROGRAMMING COMMANDS

For more advanced programmers, a complete list of the available commands is given below. These commands are described in detail in the “Programming Manual for -B Instruments”. (Note: this manual also includes some commands that are not implemented in this instrument. They can be ignored.)

<u>Keyword</u>	<u>Parameter</u>	<u>Notes</u>
OUTPut:		
:[STATe]	<boolean value>	
:PROTection		
:TRIPped?		[query only]
[SOURce]:		
:FREQuency		
[:CW FIXed]	<numeric value>	
[SOURce]:		
:PULSe		
:PERiod	<numeric value>	
:WIDTh	<numeric value> EXTeRnal	
:DCYClE	<numeric value>	
:HOLD	WIDTh DCYClE	
:DELay	<numeric value>	
:GATE		
:TYPE	ASYNc SYNc	
:LEVel	HIgh LOw	
[SOURce]:		
:VOLTage		
[:LEVel]		
[:IMMEdiate]		
[:AMPLitude]	<numeric value> EXTeRnal	
:PROTection		
:TRIPped?		[query only]
STATUS:		
:OPERation		
:[EVENT]?		[query only, always returns "0"]
:CONDition?		[query only, always returns "0"]
:ENABle	<numeric value>	[implemented but not useful]
:QUESTionable		
:[EVENT]?		[query only, always returns "0"]
:CONDition?		[query only, always returns "0"]
:ENABle	<numeric value>	[implemented but not useful]
SYSTEM:		
:COMMunicate		
:GPIB		
:ADDReSS	<numeric value>	
:SERial		
:CONTRol		
:RTS	ON IBFull RFR	
:[RECEive]		
:BAUD	1200 2400 4800 9600 19200 38400 57600 115200	
:ERRor		
:[NEXT]?		[query only]
:COUNT?		[query only]
:VERSion?		[query only]
TRIGger:		

:SOURce	INTernal EXTernal MANual HOLD IMMEDIATE	
*CLS		[no query form]
*ESE	<numeric value>	
*ESR?		[query only]
*IDN?		[query only]
*OPC		
*SAV	0 1 2 3	[no query form]
*RCL	0 1 2 3	[no query form]
*RST		[no query form]
*SRE	<numeric value>	
*STB?		[query only]
*TST?		[query only]
*WAI		[no query form]

MECHANICAL INFORMATION

TOP COVER REMOVAL

If necessary, the interior of the instrument may be accessed by removing the four Phillips screws on the top panel. With the four screws removed, the top cover may be slid back (and off).

 Always disconnect the power cord and allow the instrument to sit unpowered for 10 minutes before opening the instrument. This will allow any internal stored charge to discharge.

There are no user-adjustable internal circuits. For repairs other than fuse replacement, please contact Avtech (info@avtechpulse.com) to arrange for the instrument to be returned to the factory for repair. Service is to be performed solely by qualified service personnel.

 Caution: High voltages are present inside the instrument during normal operation. Do not operate the instrument with the cover removed.

RACK MOUNTING

A rack mounting kit is available. The -R5 rack mount kit may be installed after first removing the one Phillips screw on the side panel adjacent to the front handle.

ELECTROMAGNETIC INTERFERENCE

To prevent electromagnetic interference with other equipment, all used outputs should be connected to shielded loads using shielded coaxial cables. Unused outputs should be terminated with shielded coaxial terminators or with shielded coaxial dust caps, to prevent unintentional electromagnetic radiation. All cords and cables should be less than 3m in length.

MAINTENANCE

REGULAR MAINTENANCE

This instrument does not require any regular maintenance.

On occasion, one or more of the four rear-panel fuses may require replacement. All fuses can be accessed from the rear panel. See the “FUSES” section for details.

CLEANING

If desired, the interior of the instrument may be cleaned using compressed air to dislodge any accumulated dust. (See the “TOP COVER REMOVAL” section for instructions on accessing the interior.) No other cleaning is recommended.

TRIGGER DAMAGE

The rear-panel TRIG input, used in the external trigger mode, is protected by a diode clamping circuit. However, the protection circuit is not foolproof, and it is possible for a grossly excessive signal to damage the trigger circuitry on the main timing control board (the 4×10 inch board on the right side of the instrument).

The IC that is most likely to fail under these conditions is installed in a socket. It is a standard TTL IC in a 16-pin plastic DIP package, model 74F151 or equivalent.

If you suspect that this IC has been damaged, turn off the power and replace this IC. It may be replaced by a 74F151, 74LS151, 74ALS151, or 74HCT151.

WIRING OF AC POWER

WIRING DIAGRAMS

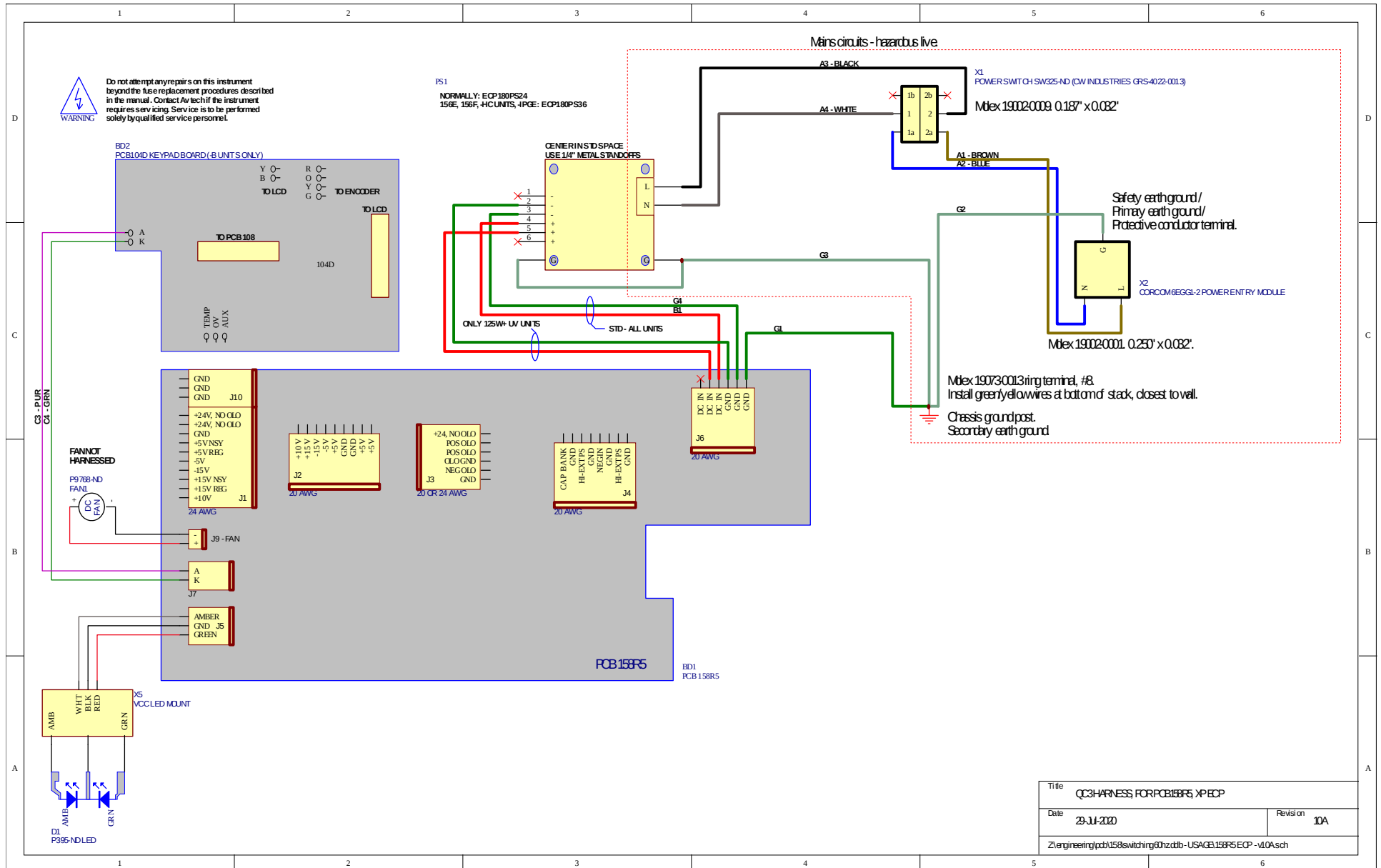

Title		QC3 HARNESS FOR PCB158F5 XPECP	
Date	29-11-2020	Revision	10A
Z:\engineering\pcb158switching04hzddb-USAGE\158F5 ECP -V1.0A.sch			

PCB 158R5 - LOW VOLTAGE POWER SUPPLY

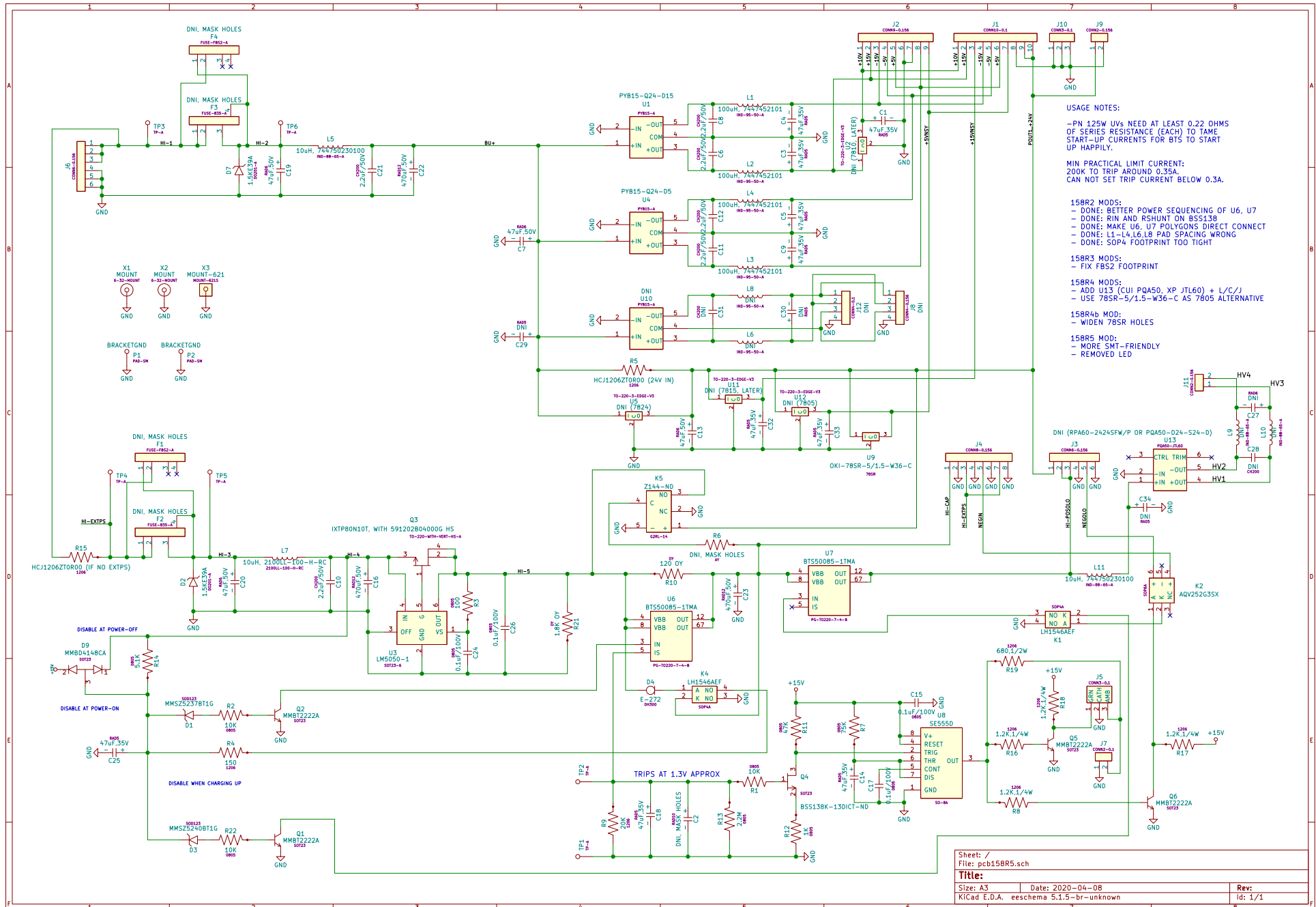

PCB 284B - HIGH VOLTAGE DC POWER SUPPLY

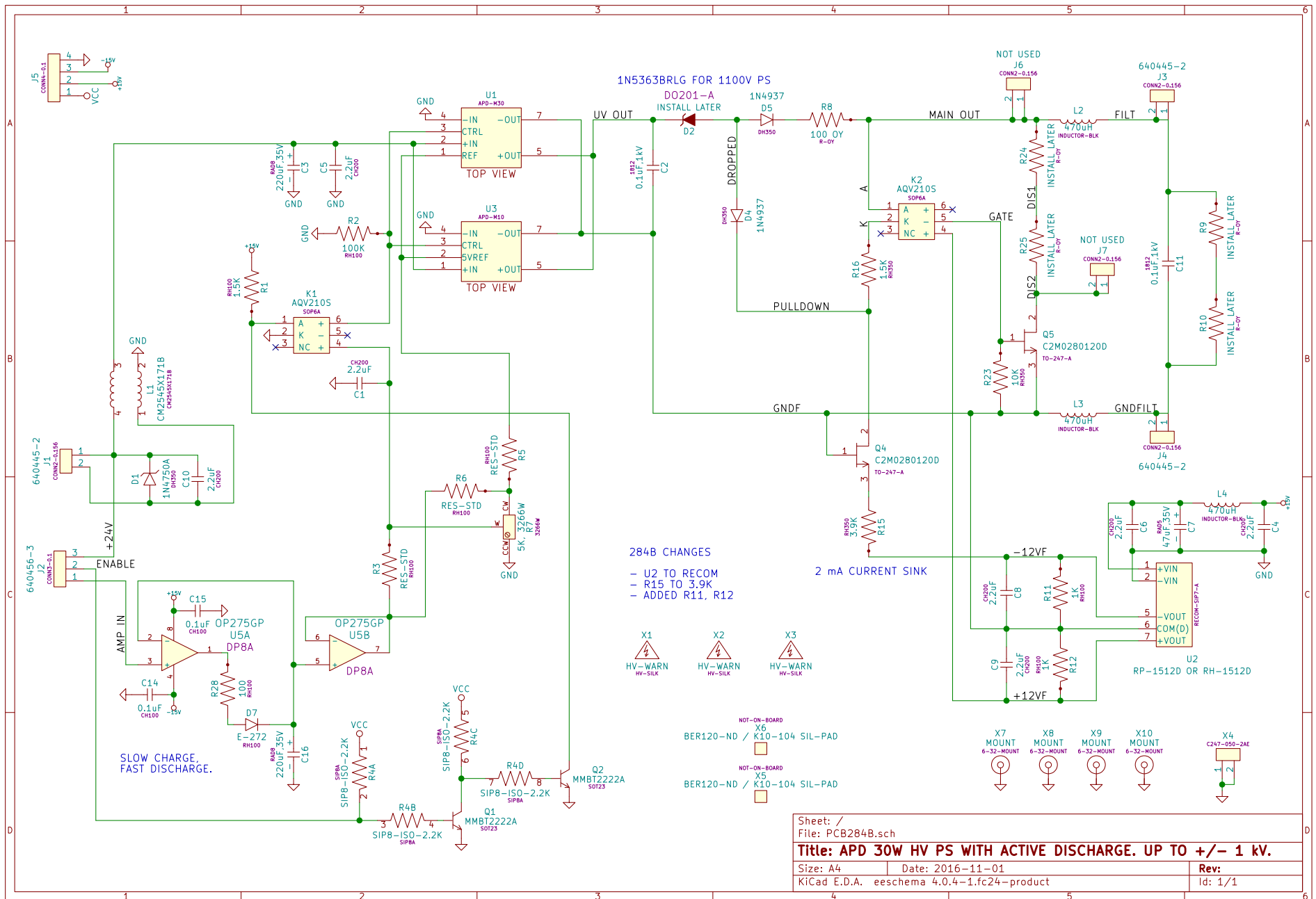

PCB 156D - POLARITY CONTROL PCB

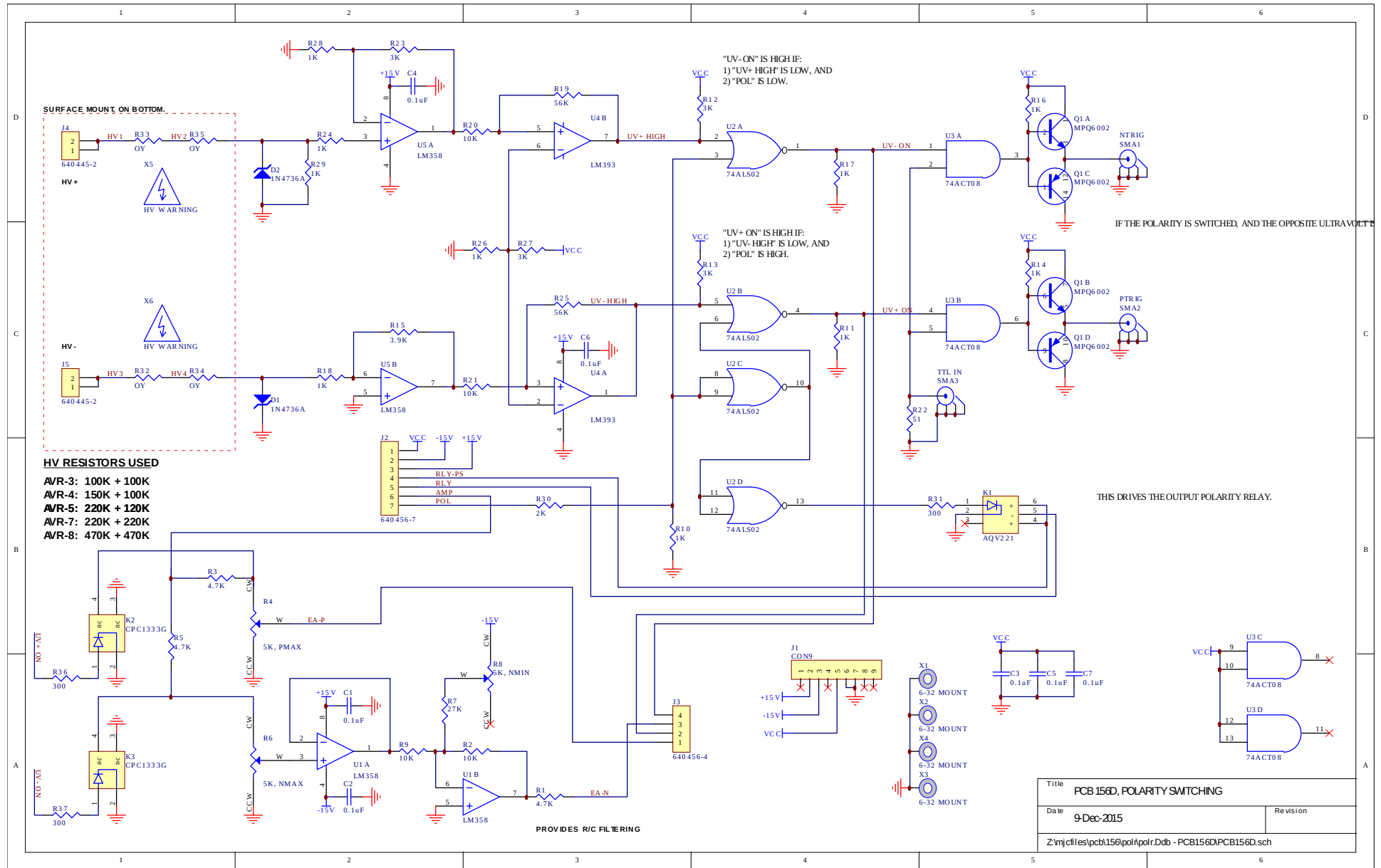

PCB 104G - KEYPAD / DISPLAY BOARD

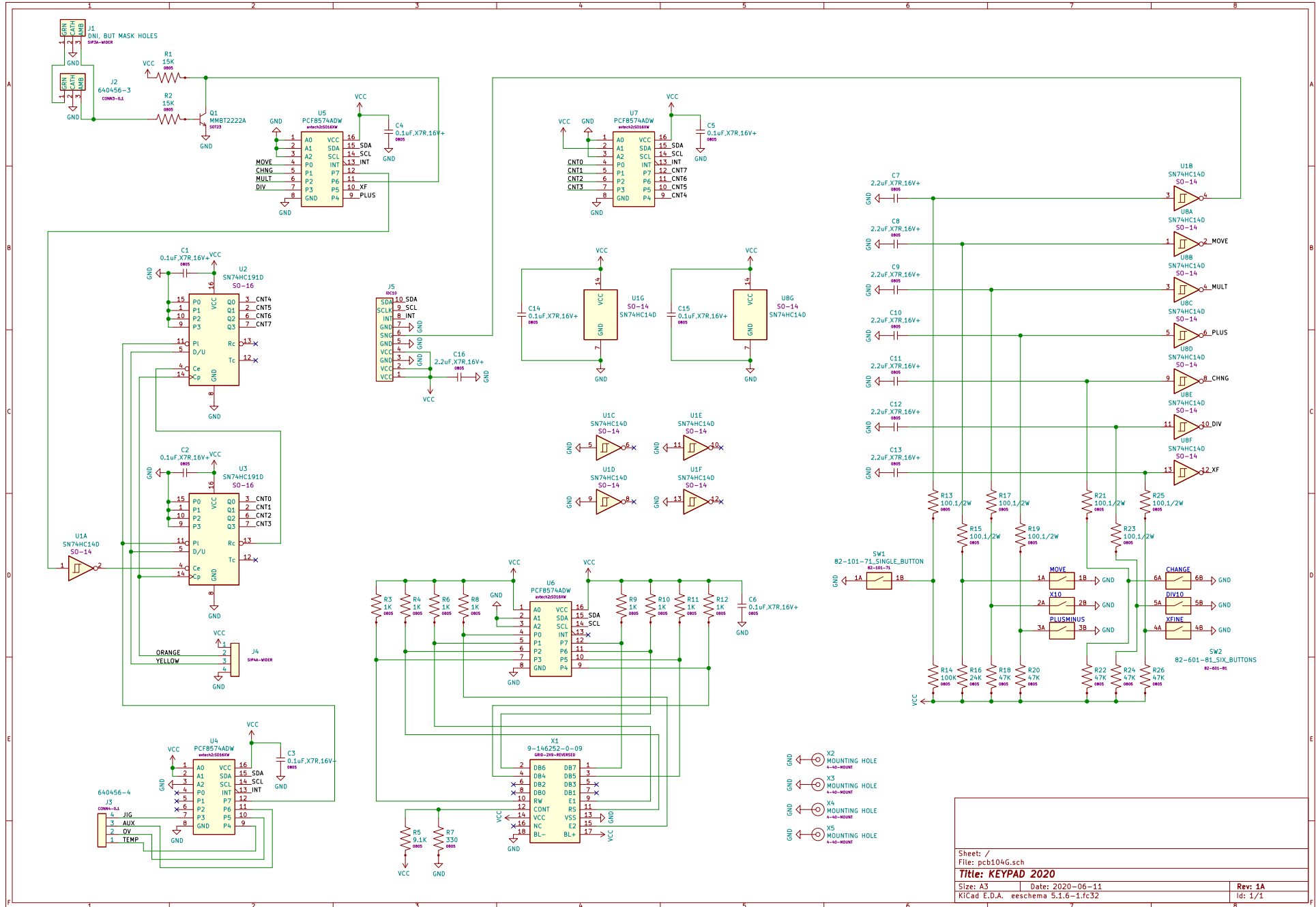

INTERLOCK CIRCUIT

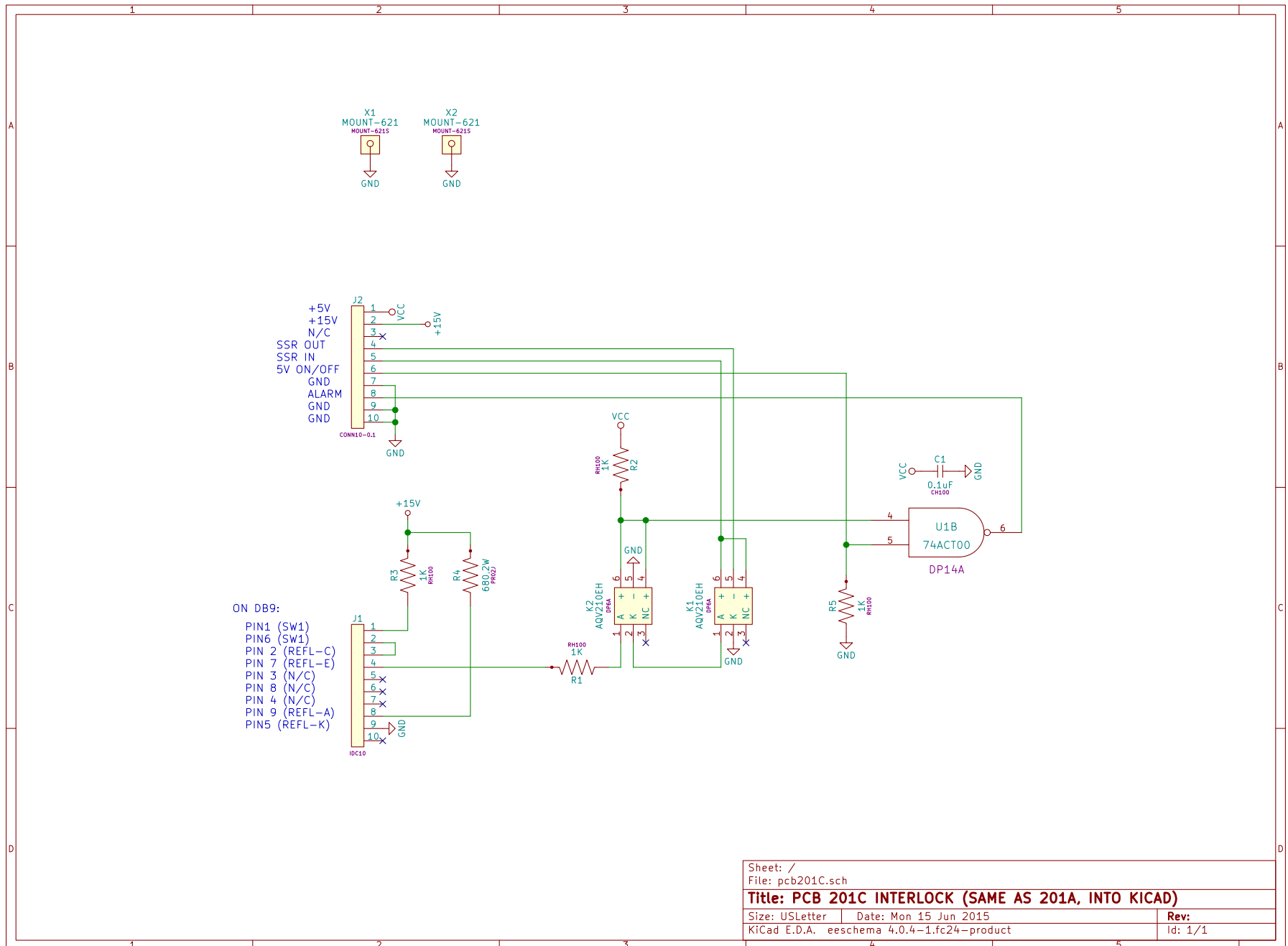

Sheet: /		
File: pcb201C.sch		
Title: PCB 201C INTERLOCK (SAME AS 201A, INTO KICAD)		
Size: USLetter	Date: Mon 15 Jun 2015	Rev:
KiCad E.D.A. eeschema 4.0.4-1.fc24-product		Id: 1/1

MAIN WIRING

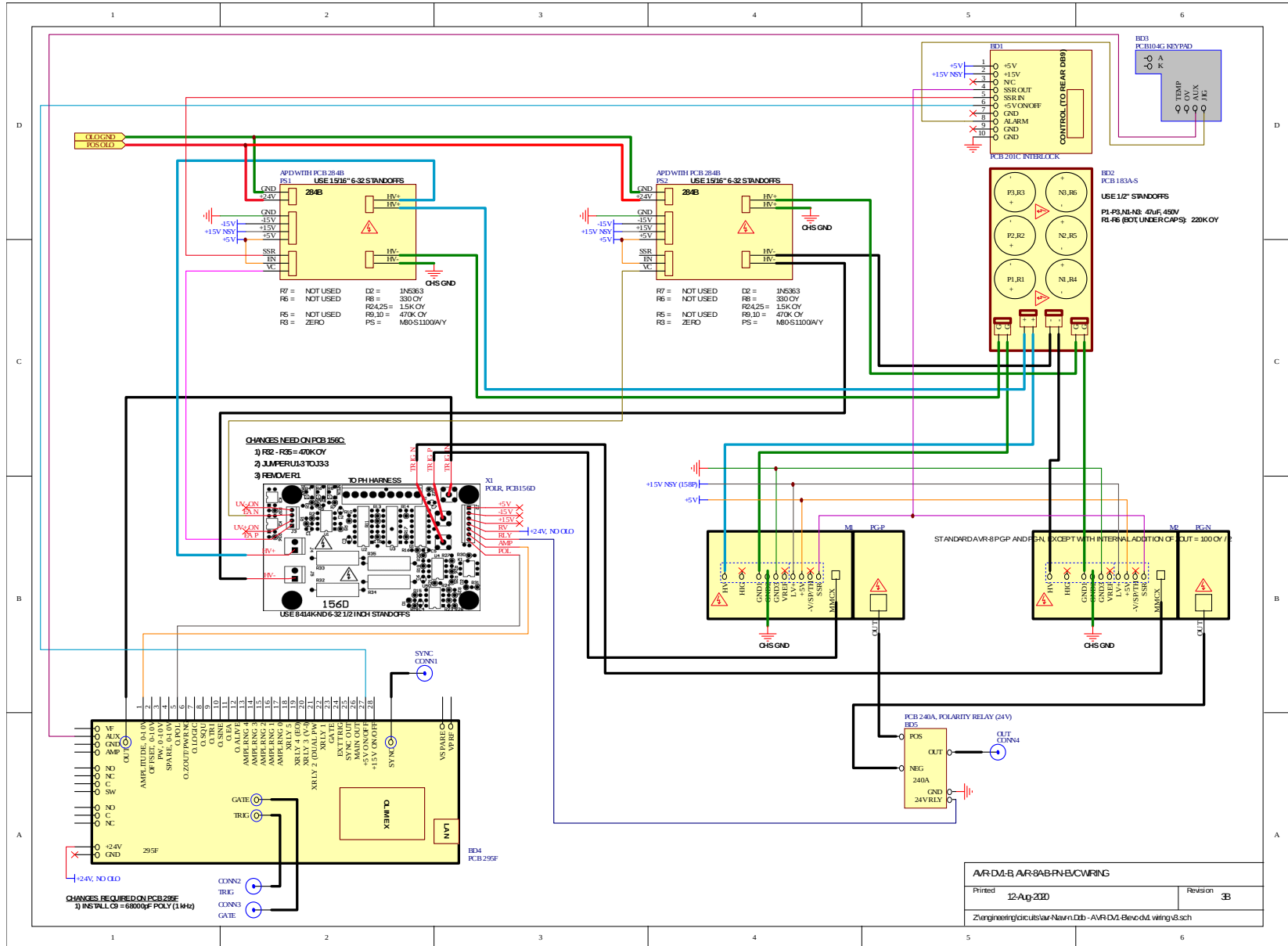

PCB 200B - TEST JIG

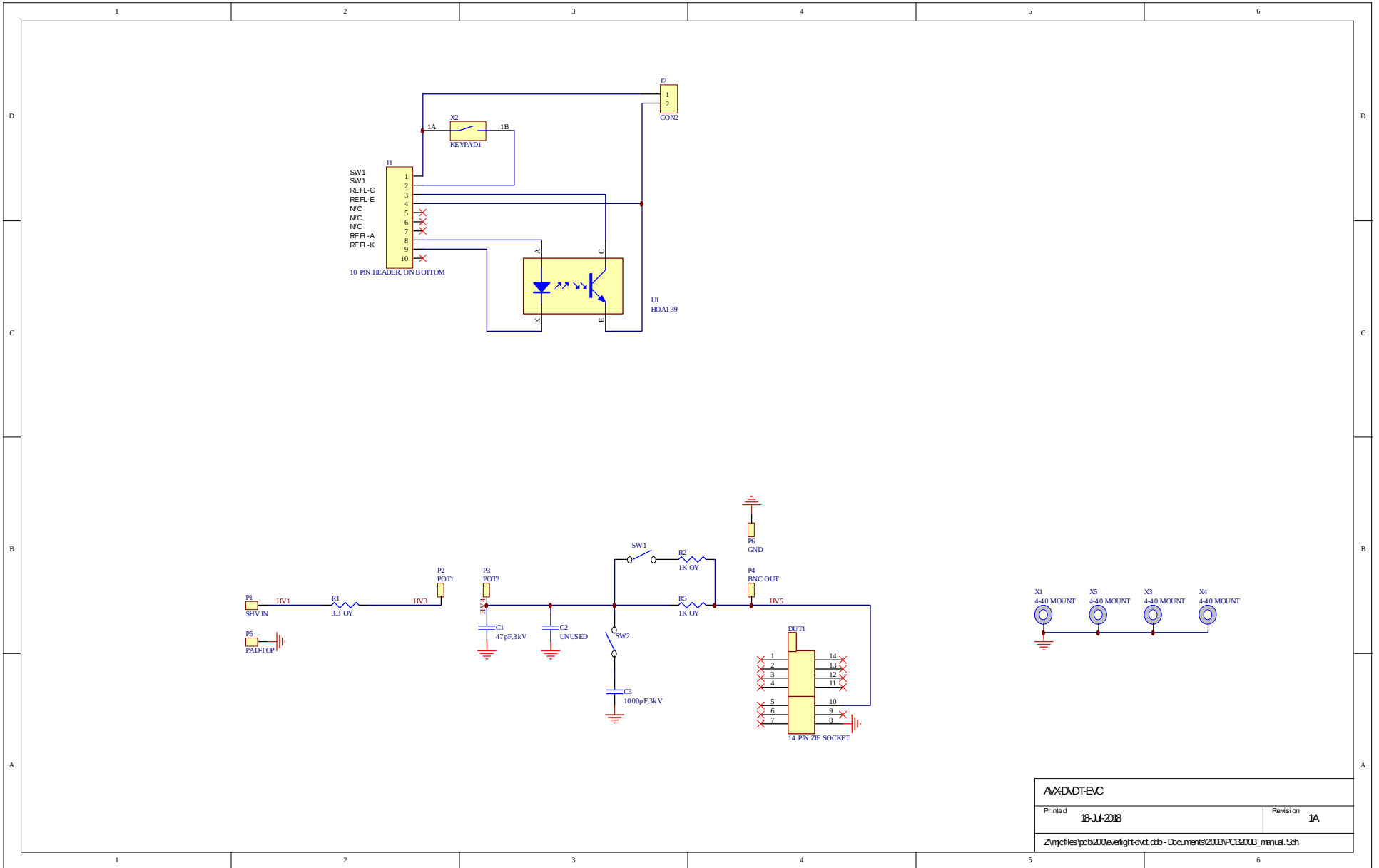

A:\XDMT-EVC	
Printed	Revision 1A
Z:\mjc\files\pcb200\everlight\dtd.dtb - Documents\200B\PCB200B_manual.Sch	

TEST JIG WIRING

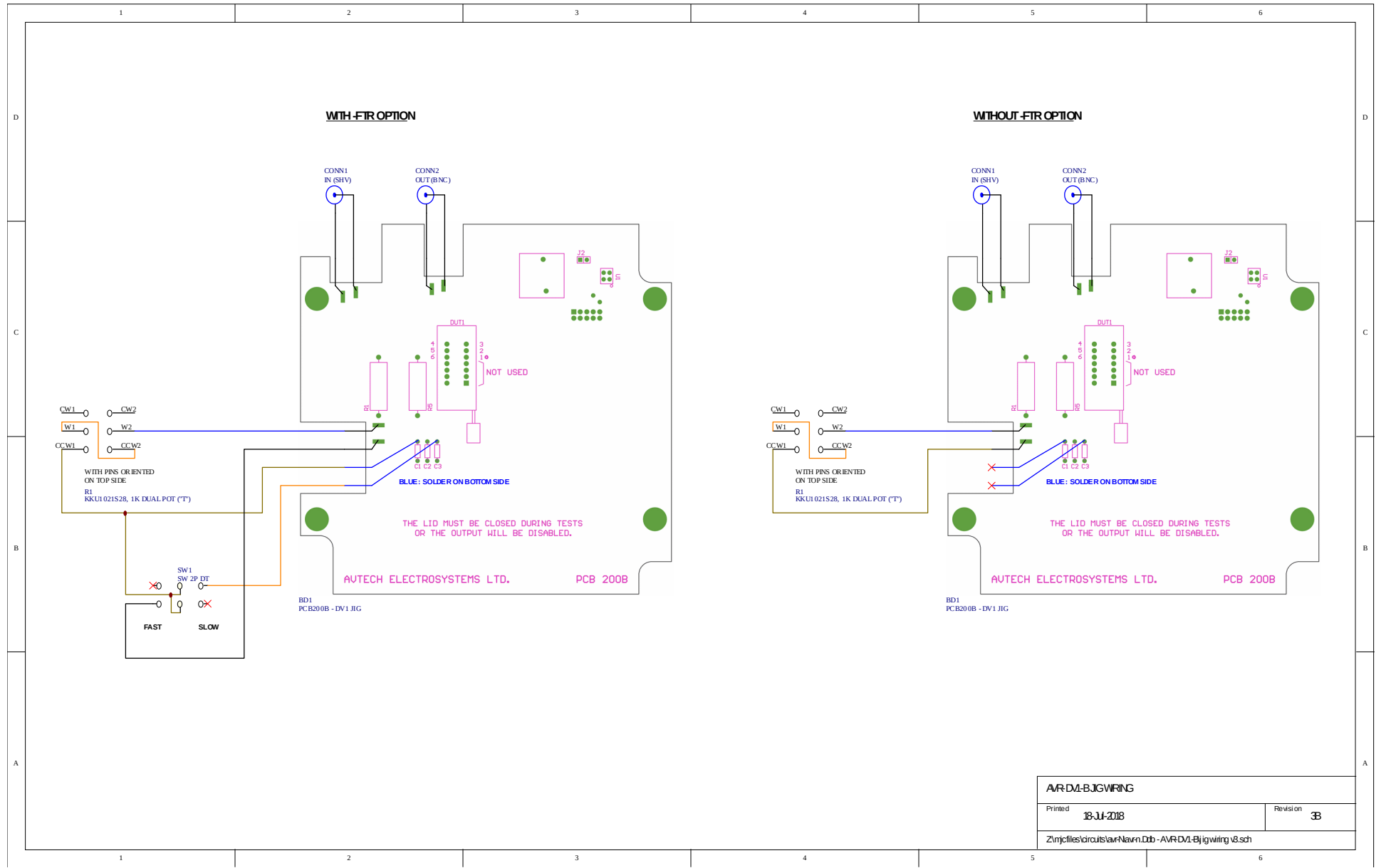

PERFORMANCE CHECK SHEET