

INSTRUCTIONS

MODEL AVR-E3-N-PS-LA2 PULSE GENERATOR

S.N.:

WARRANTY

Avtech Electrosystems Ltd. warrants products of its manufacture to be free from defects in material and workmanship under conditions of normal use. If, within one year after delivery to the original owner, and after prepaid return by the original owner, this Avtech product is found to be defective, Avtech shall at its option repair or replace said defective item. This warranty does not apply to units which have been disassembled, modified or subjected to conditions exceeding the applicable specifications or ratings. This warranty is the extent of the obligation assumed by Avtech with respect to this product and no other warranty or guarantee is either expressed or implied.

TECHNICAL SUPPORT

Phone: 613-226-5772 or 1-800-265-6681

Fax: 613-226-2802 or 1-800-561-1970

E-mail: info@avtechpulse.com

World Wide Web: <http://www.avtechpulse.com>

TABLE OF CONTENTS

WARRANTY.....2

TABLE OF CONTENTS.....3

FIG. 2: TEST ARRANGEMENT.....4

GENERAL OPERATING INSTRUCTIONS.....5

POWER SUPPLY AND FUSE REPLACEMENT.....8

ORIGINAL QUOTATION.....10

PERFORMANCE CHECK SHEET.....11

Manual Reference: /fileserver1/officefiles/instructword/avr-e/OBS/AVR-E3-N-PS-LA2, edition 1.doc, created June 18, 2001

FIG. 2: TEST ARRANGEMENT

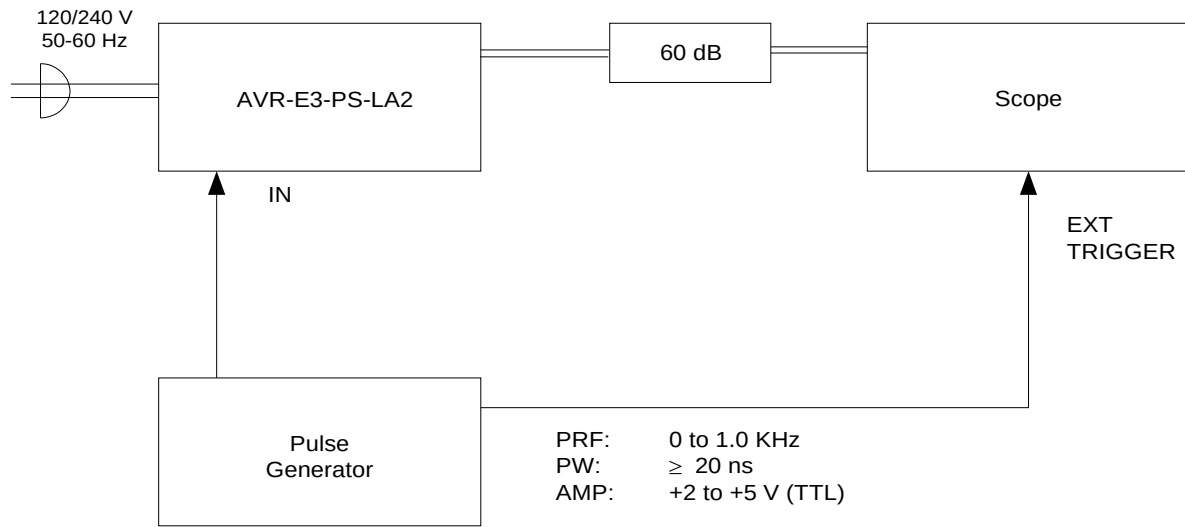

GENERAL OPERATING INSTRUCTIONS

- 1) The bandwidth capability of components and instruments used to display the pulse generator output signal (attenuators, cables, connectors, etc.) should exceed 2 GHz.
- 2) The use of 60 dB attenuator at the scope vertical input channel will insure a peak input signal to the scope of less than one Volt (necessary only if sampling scope used). If a high impedance real time scope is used, the pulse generator should be terminated using a shunt 50-Ohm resistor. Note that for proper and reliable operation, this unit requires a 50-Ohm termination at all times.
- 3) The output pulse width is controlled by means of the front panel one-turn PW control.
- 4) The output pulse amplitude is controlled by means of the front panel one-turn AMP control.
- 5) Note that at amplitudes below 20 Volts, the overshoot on the rising edge may be excessively high and for that reason it is recommended that attenuators be used for such applications.
- 6) The maximum burst repetition rate is 1 KHz, with a maximum of 12 pulses per burst and a minimum spacing between pulses of 350 ns.
- 7) AVR-E units with a serial number higher than 5600 are protected by an automatic overload protective circuit, which controls the front panel overload light. If the unit is overloaded (by operating at an exceedingly high duty cycle or by operating into a short circuit), the protective circuit will turn the output of the instrument OFF and the indicator light ON. The light will stay ON (i.e. output OFF) for about 5 seconds after which the instrument will attempt to turn ON (i.e. light OFF) for about 1 second. If the overload condition persists, the instrument will turn OFF again (i.e. light ON) for another 5 seconds. If the overload condition has been removed, the instrument will turn on and resume normal operation. Overload conditions may be removed by:
 - 1) Reducing PRF (i.e. switch to a lower range)
 - 2) Reducing pulse width (i.e. switch to a lower range)
 - 3) Removing output load short circuit (if any)

Note that the overload light may illuminate when the prime power is applied. The light will extinguish after a few seconds and the unit will then function normally.

8) The unit can be converted from 120/240 50-60 Hz operation by adjusting the voltage selector card in the rear panel fused voltage selector-cable connector assembly.

9) For additional assistance:

Tel: (613) 226-5772

Fax: (613) 226-2802

Email: info@avtechpulse.com

POWER SUPPLY AND FUSE REPLACEMENT

This instrument has three fuses (plus one spare). One, which protects the AC input, is located in the rear-panel power entry module, as described in the “Rear Panel Controls” section of this manual. If the power appears to have failed, check the AC fuse first.

The other two fuses (plus one spare) are located on the internal DC power supply, as shown below:

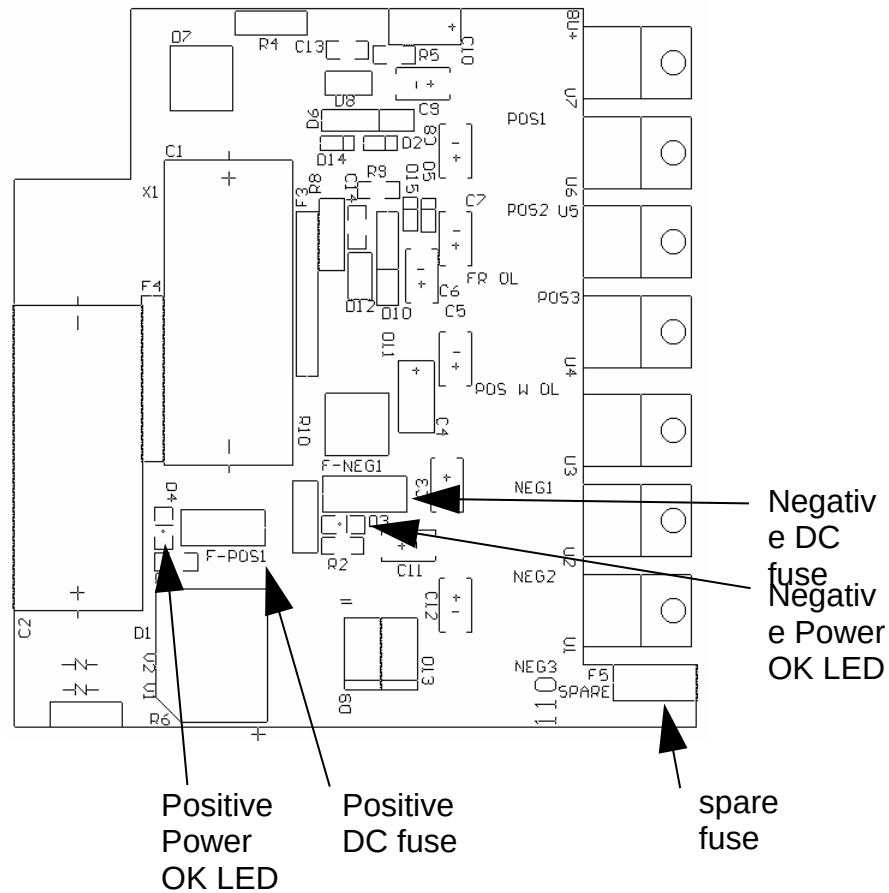

The spare fuse may be used to replace one of the other fuses, if required.

The three fuses on this circuit board are 0.5A slow-blow fuses, Littlefuse part number R452.500. (This fuse can be ordered from Digikey, www.digikey.com. The Digikey part number is F1341CT-ND).

If you suspect that the DC fuses are blown, follow this procedure:

1. Remove the top cover, by removing the four Phillips screws on the top cover and then sliding the cover back and off.
2. Locate the two "Power OK" LEDs on the power supply circuit board, as illustrated above.
3. Turn on the instrument.
4. Observe the "Power OK" LEDs. If the fuses are not blown, the two LEDs will be lit (bright red). If one of the LEDs is not lit, the fuse next to it has blown.
5. Turn off the instrument.
6. If a fuse is blown, use needle-nose pliers to remove the blown fuse from its surface-mount holder.
7. Replace the fuse.

ORIGINAL QUOTATION

PERFORMANCE CHECK SHEET