



AVTECH ELECTROSYSTEMS LTD.

NANOSECOND WAVEFORM ELECTRONICS
SINCE 1975

P.O. BOX 265
OGDENSBURG, NY
U.S.A. 13669-0265
TEL: (315) 472-5270
FAX: (613) 226-2802

TEL: 1-800-265-6681
FAX: 1-800-561-1970

e-mail: info@avtechpulse.com
<http://www.avtechpulse.com/>

BOX 5120, LCD MERIVALE
OTTAWA, ONTARIO
CANADA K2C 3H4
TEL: (613) 226-5772
FAX: (613) 226-2802

INSTRUCTIONS

MODEL AVR-EB2-C

0 TO $\pm 50V$ (0 to $\pm 0.5A$) PULSE GENERATOR
FOR MIL-STD-750C METHOD
4031.1 AND 4026.2 T_{RR} AND T_{FR} TESTS

SERIAL NUMBER: _____

WARRANTY

Avtech Electrosystems Ltd. warrants products of its manufacture to be free from defects in material and workmanship under conditions of normal use. If, within one year after delivery to the original owner, and after prepaid return by the original owner, this Avtech product is found to be defective, Avtech shall at its option repair or replace said defective item. This warranty does not apply to units which have been disassembled, modified or subjected to conditions exceeding the applicable specifications or ratings. This warranty is the extent of the obligation assumed by Avtech with respect to this product and no other warranty or guarantee is either expressed or implied.

TECHNICAL SUPPORT

Phone: 613-226-5772 or 1-800-265-6681

Fax: 613-226-2802 or 1-800-561-1970

E-mail: info@avtechpulse.com

World Wide Web: <http://www.avtechpulse.com>

TABLE OF CONTENTS

WARRANTY.....	2
TECHNICAL SUPPORT.....	2
TABLE OF CONTENTS.....	3
INTRODUCTION.....	5
SPECIFICATIONS.....	6
EC DECLARATION OF CONFORMITY.....	7
INSTALLATION.....	8
VISUAL CHECK.....	8
POWER RATINGS.....	8
CONNECTION TO THE POWER SUPPLY.....	8
ENVIRONMENTAL CONDITIONS.....	8
FUSES.....	9
AC FUSE REPLACEMENT.....	9
DC FUSE REPLACEMENT.....	10
FUSE RATINGS.....	10
FRONT PANEL CONTROLS.....	11
REAR PANEL CONTROLS.....	13
GENERAL INFORMATION.....	14
BASIC PULSE CONTROL.....	14
PERFORMING FORWARD RECOVERY TESTS.....	16
EXAMPLE PROCEDURE - FORWARD RECOVERY TEST WITH A 1N4150 DIODE.....	18
PERFORMING METHOD 4031.1 REVERSE RECOVERY TESTS.....	19
EXAMPLE PROCEDURE - REVERSE RECOVERY TEST WITH A 1N4150 DIODE.....	21
USING TEST JIGS.....	24
MECHANICAL INFORMATION.....	25
TOP COVER REMOVAL.....	25
RACK MOUNTING.....	25
ELECTROMAGNETIC INTERFERENCE.....	25
MAINTENANCE.....	26
REGULAR MAINTENANCE.....	26
CLEANING.....	26
PERFORMANCE CHECK SHEET.....	27

Manual Reference: /fileserver1/officefiles/instructword/avr-eb/avr-eb2/AVR-EB2-C, edition1.sxw.
Copyright © 2003 Avtech Electrosystems Ltd, All Rights Reserved.

INTRODUCTION

The AVR-EB-C series was specifically designed to provide the diode switching time test waveforms specified in MIL-STD-750C, Methods 4031.1 and 4026.2 for T_{RR} and T_{FR} . This instrument unit generates two pulsed outputs (a positive turn-on waveform and a negative turn-off waveform) and provides the necessary variable delay between the two outputs. The two outputs may also be used separately for other applications.

One output generates amplitudes of 0 to +50V, and a second output generates amplitudes of 0 to -50V. When used in junction with an appropriate test jig, the model AVR-EB2-C can provide diode test currents as high as 0.5 Amps. The negative output has a rise time of less than 0.5 ns, which allows the testing of ultra-fast diodes. The positive output has a rise time of less than 5 ns.

The AVR-EB2-C can be triggered internally, or by an external source. A front-panel pushbutton can also be used to trigger the instrument.

This instrument is intended for use in research and development laboratories.

SPECIFICATIONS

Model:	AVR-EB2-C	
Channel:	1	2
Output amplitude:	0 to -50V	0 to +50V
Diode current max:	-0.5A	+0.5A
Pulse width:	20 to 200 ns	0.1 to 5.0 us
Rise, fall time:	0.5 ns	5.0 ns
Source Impedance:	$\leq 2 \Omega$	
PRF:	2 Hz to 20 kHz	
Delay:	0 to 5 us (channel 1 to channel 2)	
Connectors:	BNC	
External Trigger:	+5 Volt, 50 ns or wider (TTL).	
Sync output:	+3 Volts, 200 ns, will drive 50 Ohm loads. Internal trigger mode only.	
Dimensions (H x W x D):	100 mm x 430 mm x 375 mm (3.9" x 17" x 14.8")	
Prime power:	115 / 230 V \pm 10%, 50-60 Hz	
Chassis material:	Cast aluminum frame and handles, blue vinyl on aluminum cover plates	
Mounting:	Any	
Temperature range:	+15° to +40° C	

EC DECLARATION OF CONFORMITY

We

Avtech Electrosystems Ltd.
P.O. Box 5120, LCD Merivale
Ottawa, Ontario
Canada K2C 3H4

declare that this pulse generator meets the intent of Directive 89/336/EEC for Electromagnetic Compatibility. Compliance pertains to the following specifications as listed in the official Journal of the European Communities:

EN 50081-1 Emission

EN 50082-1 Immunity

and that this pulse generator meets the intent of the Low Voltage Directive 72/23/EEC as amended by 93/68/EEC. Compliance pertains to the following specifications as listed in the official Journal of the European Communities:

EN 61010-1:2001 Safety requirements for electrical equipment for measurement, control, and laboratory use

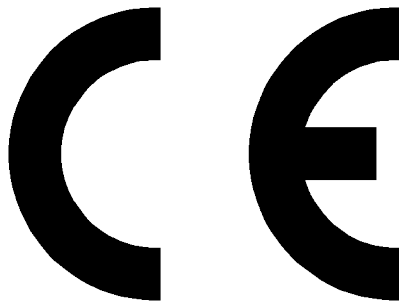

INSTALLATION

VISUAL CHECK

After unpacking the instrument mainframe and the transformer module, examine to ensure that they have not been damaged in shipment. Visually inspect all connectors, knobs, and handles. Confirm that a power cord and an instrumentation manual (this manual), are with the instrument. If the instrument has been damaged, file a claim immediately with the company that transported the instrument.

POWER RATINGS

This instrument is intended to operate from 115 / 230 V \pm 10%, 50-60 Hz. The instrument automatically switches between these two levels. Note, however, that different fuses are required for the two ranges, as described in the "FUSES" section.

The maximum power consumption is 57 Watts. This instrument is an "Installation Category II" instrument, intended for operation from a normal single-phase supply.

CONNECTION TO THE POWER SUPPLY

An IEC-320 three-pronged recessed male socket is provided on the back panel for AC power connection to the instrument. One end of the detachable power cord that is supplied with the instrument plugs into this socket. The other end of the detachable power cord plugs into the local mains supply. Use only the cable supplied with the instrument. The mains supply must be earthed, and the cable used to connect the instrument to the mains supply must provide an earth connection. (The supplied cable does this.)

ENVIRONMENTAL CONDITIONS

This instrument is intended for use under the following conditions:

1. indoor use;
2. altitude up to 2 000 m;
3. temperature 5 °C to 40 °C;
4. maximum relative humidity 80 % for temperatures up to 31 °C decreasing linearly to 50 % relative humidity at 40 °C;
5. Mains supply voltage fluctuations up to \pm 10 % of the nominal voltage;
6. no pollution or only dry, non-conductive pollution.

FUSES

This instrument contains four fuses. All are accessible from the rear-panel. Two protect the AC prime power input, and two protect the internal DC power supplies. The locations of the fuses on the rear panel are shown in the figure below:

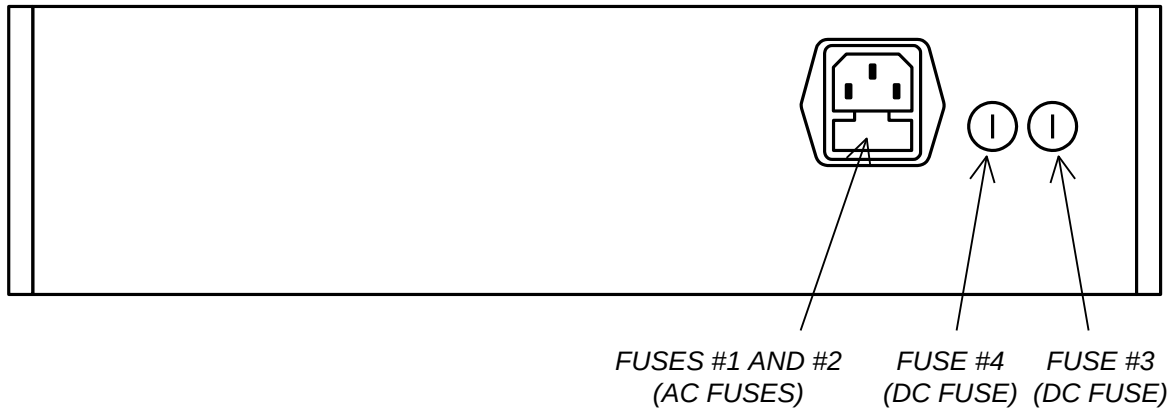

AC FUSE REPLACEMENT

To physically access the AC fuses, the power cord must be detached from the rear panel of the instrument. The fuse drawer may then be extracted using a small flat-head screwdriver, as shown below:

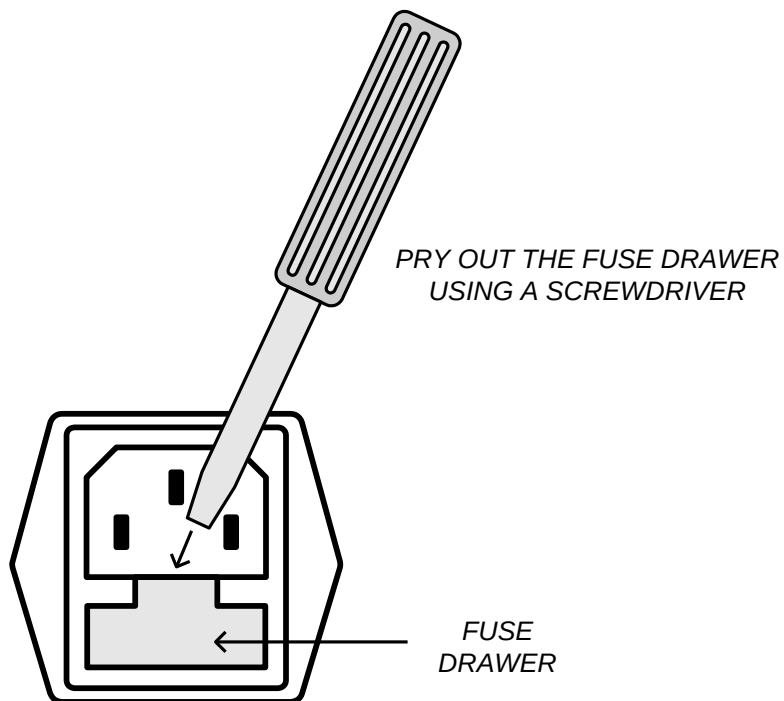

DC FUSE REPLACEMENT

The DC fuses may be replaced by inserting the tip of a flat-head screwdriver into the fuse holder slot, and rotating the slot counter-clockwise. The fuse and its carrier will then pop out.

FUSE RATINGS

The following table lists the required fuses:

Fuses	Mains Voltage	Rating	Case Size	Manufacturer's Part Number (Wickmann)	Distributor's Part Number (Digi-Key)
#1, #2 (AC)	115 V	0.5A, 250V, Time-Delay	5 x 20 mm	1950500000	WK5041-ND
	230 V	0.25A, 250V, Time-Delay	5 x 20 mm	1950250000	WK5035-ND
#3 (DC)	115/230V	1.6A, 250V, Time-Delay	5 x 20 mm	1951160000	WK5053-ND
#4 (DC)	115/230V	0.8A, 250V, Time-Delay	5 x 20 mm	1950800000	WK5046-ND

The fuse manufacturer is Wickmann (<http://www.wickmann.com/>).

Replacement fuses may be easily obtained from Digi-Key (<http://www.digikey.com/>) and other distributors.

FRONT PANEL CONTROLS

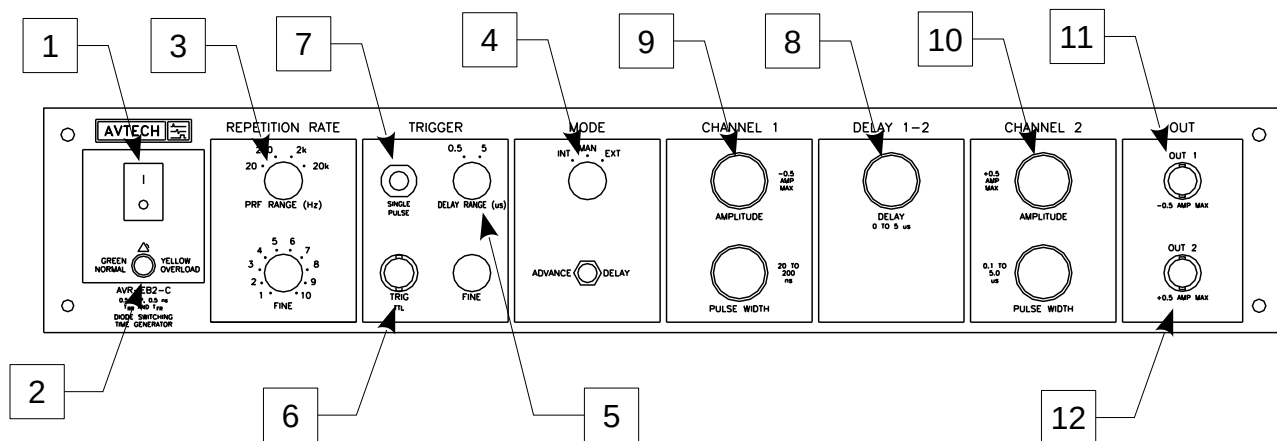

- 1. POWER Switch.** This is the main power switch. When turning the instrument on, there may be a delay of several seconds before the instrument appears to respond.
- 2. OVERLOAD Indicator.** When the instrument is powered, this indicator is normally green, indicating normal operation. If this indicator is yellow, an internal automatic overload protection circuit has been tripped. If the unit is overloaded (by operating at an exceedingly high duty cycle or by operating into a very low impedance), the protective circuit will disable the output of the instrument and turn the indicator light yellow. The light will stay yellow (i.e. output disabled) for about 5 seconds after which the instrument will attempt to re-enable the output (i.e. light green) for about 1 second. If the overload condition persists, the output will be disabled again (i.e. light yellow) for another 5 seconds. If the overload condition has been removed, the instrument will resume normal operation.

This overload indicator may flash yellow briefly at start-up. This is not a cause for concern.
- 3. REPETITION RATE Controls.** The rotary switch marked "RANGE" selects the pulse repetition rate for the internally triggered mode. The vernier (labeled "FINE") provides continuously variable control of each range. The instrument is set to the rate indicated on the front panel when the vernier is in the "MAX" position.
- 4. MODE Switch.** With this switch in the INT position, the repetition rate of the unit is controlled by an internal oscillator, which in turn is controlled by the REPETITION RATE controls.

With the switch in the EXT position, the unit requires a 50 ns (or wider) TTL level pulse applied at the TRIG input in order to trigger the output stages.

For a single pulse output, the switch should be in the "MAN" position, and then push

the SINGLE PULSE pushbutton.

5. TRIGGER DELAY Control. Controls the relative delay between the reference output pulse provided at the TRIG output and the main outputs. This delay is variable over the range of 0 to 5 us. The TRIG output precedes the main outputs when the ADVANCE-DELAY switch is in the ADVANCE position and lags when the switch is in the DELAY position. This delay control affects both of the two main outputs simultaneously. It does not affect the relay delay between the two main outputs.
6. TRIG Connector. When the MODE switch is set to the “EXT” position, a TTL-level pulse applied to this connector will trigger the instrument. The instrument triggers on the rising edge of this input. The input impedance of this input is 1 k Ω . (Depending on the length of cable attached to this input, and the source driving it, it may be desirable to add a coaxial 50 Ohm terminator to this input to provide a proper transmission line termination. The Pasternack (www.pasternack.com) PE6008-50 BNC feed-thru 50 Ohm terminator is suggested for this purpose.)

When the MODE switch is set to the “INT” position, this connector is used as an output that generates a 200 ns wide TTL-level pulse for each trigger event. This output can be used to trigger an oscilloscope, or other test equipment. The separation between the main output pulse and the TRIG output pulse is controlled by the DELAY controls and the ADVANCE/DELAY switch. For this output to operate correctly, the delay setting must be less than the period.

7. SINGLE PULSE Pushbutton. When the MODE switch is in the “MAN” position, the instrument can be triggered by pressing this pushbutton. A single pulse is generated for each button press.
8. DELAY 1-2 Control. Controls the relative delay between the two main outputs. This delay is variable over the range of 0 to 5 us. OUT 2, the positive output, always precedes OUT 1, the negative output.
9. OUT 1 AMPLITUDE & PULSE WIDTH Controls. These two dials control the amplitude and pulse width of OUT 1 (the negative output).
10. OUT 2 AMPLITUDE & PULSE WIDTH Controls. These two dials control the amplitude and pulse width of OUT 2 (the positive output).
11. OUT 1 CONNECTOR. This BNC connector provides the negative output signal. The amplitude of this output can be varied from 0 to -50V.
12. OUT 2 CONNECTOR. This BNC connector provides the positive output signal. The amplitude of this output can be varied from 0 to +50V.

REAR PANEL CONTROLS

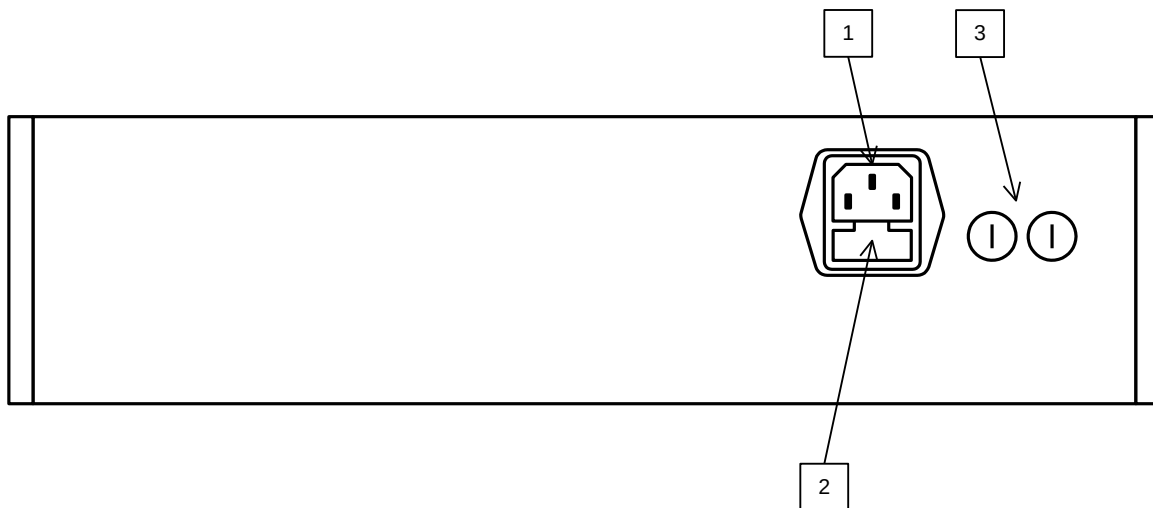

1. AC POWER INPUT. An IEC-320 C14 three-pronged recessed male socket is provided on the back panel for AC power connection to the instrument. One end of the detachable power cord that is supplied with the instrument plugs into this socket.
2. AC FUSE DRAWER. The two fuses that protect the AC input are located in this drawer. Please see the “FUSES” section of this manual for more information.
3. DC FUSES. These two fuses protect the internal DC power supplies. Please see the “FUSES” sections of this manual for more information.

GENERAL INFORMATION

BASIC PULSE CONTROL

This instrument can be triggered by its own internal clock or by an external TTL trigger signal. In either case, two main output channels respond to the trigger: OUT 1 and OUT 2. When triggering internally, the TRIG connector also provides a synchronizing output. The OUT 1 channel is a negative amplitude signal that may either drive a 50 Ohm load, or a test jig (described later). Its amplitude and pulse width are variable. The OUT 2 channel is a positive amplitude signal that may either drive a 50 Ohm load, or the test jig described later. Its amplitude and pulse width are also variable. The TRIG pulse is a fixed-width TTL-level reference pulse used to trigger oscilloscopes or other measurement systems. When the ADVANCE/DELAY switch is set to ADVANCE the TRIG pulse precedes the OUT 1 & 2 pulses. When the ADVANCE/DELAY switch is set to DELAY the TRIG pulse follows the OUT 1 & 2 pulses.

These pulses are illustrated below, assuming internal triggering and ADVANCE mode:

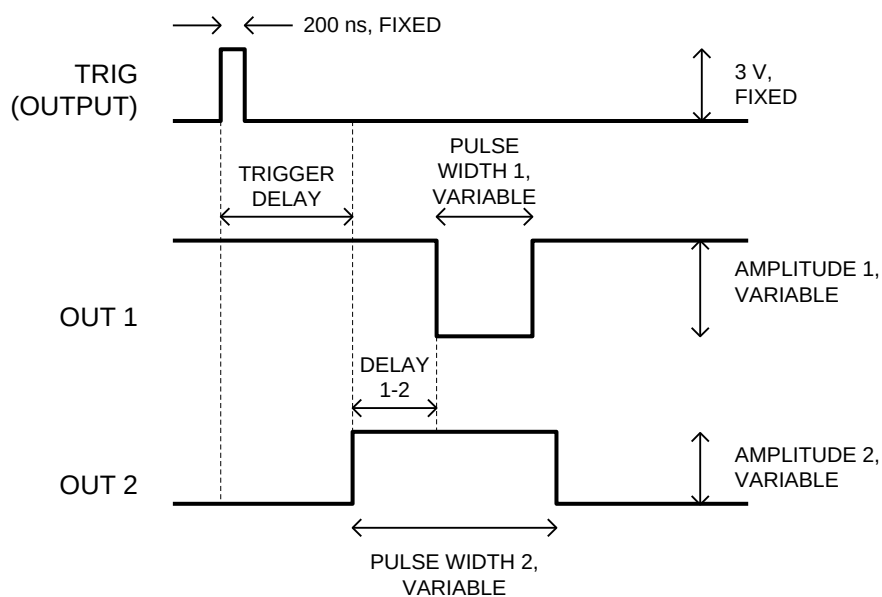
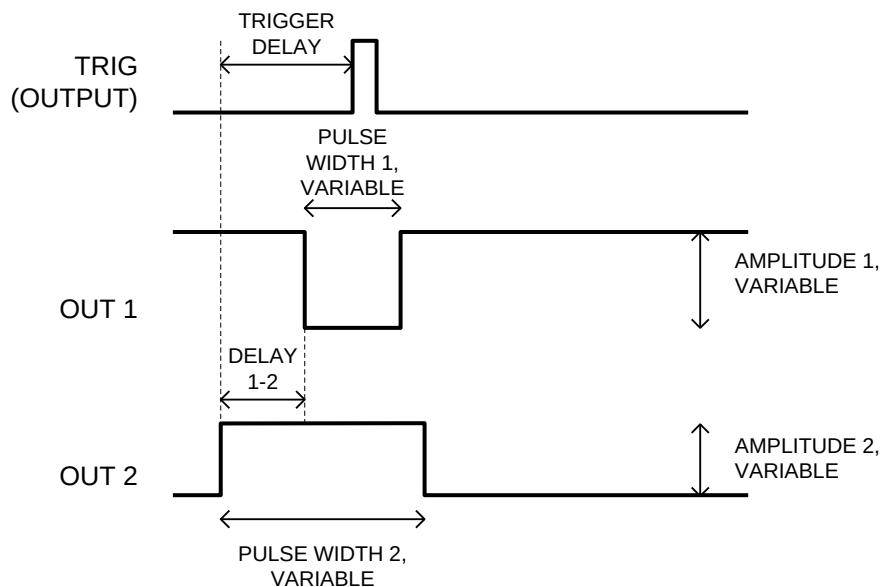

Figure A

The order of the TRIG and OUT pulses is reversed for DELAY mode:

Figure B



The next figure illustrates the relationship between the signals when an external TTL-level trigger is used:

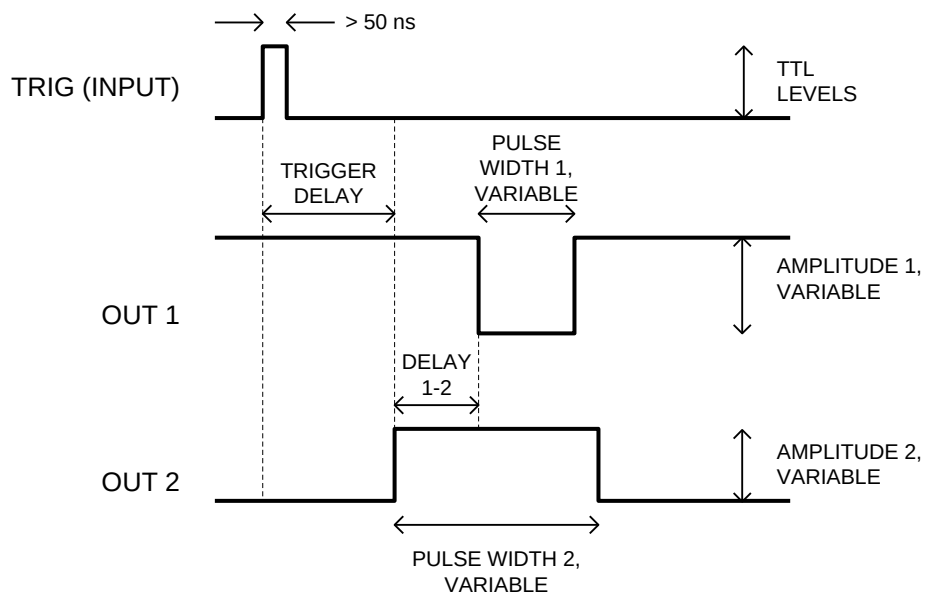

Figure C

PERFORMING FORWARD RECOVERY TESTS

Although the AVR-EB2-C can be used as a two-channel 50Ω pulse generator, the two outputs are normally used together to drive special-purpose test jigs. These test jigs are normally user-supplied. These test jigs are used to perform the MIL-STD-750C Methods 4031.1 and 4026.2 diode recovery tests.

When performing Method 4026.2 tests, the basic approach is to pulse a series combination of a resistor and the device under test with a positive voltage. (A shunt resistor is added to provide proper transmission line termination.) The basic setup is shown below, when used with a sampling oscilloscope:

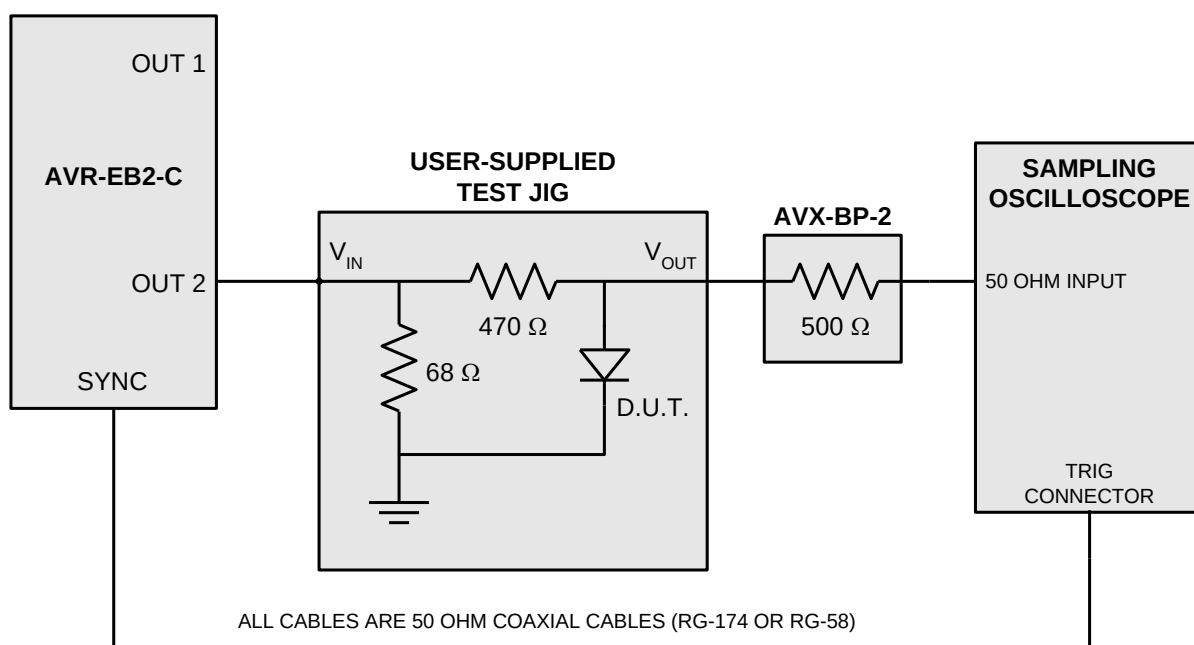

Figure D

The AVX-BP-2 is included to boost the apparent input impedance of the oscilloscope. (According to the 4026.2 specification, the impedance of the measuring device must be greater than $20 V_F/I_F$, which for a typical diode with 0.7V forward voltage, tested at 50 mA, would be $20 \times 0.7 / 0.05 = 280 \Omega$. Thus, the 50 Ω input impedance of a typical sampling oscilloscope is too low.) Alternatively, if the diode recovery time is relatively slow, a real-time oscilloscope may be used instead, in which case the following connections should be used:

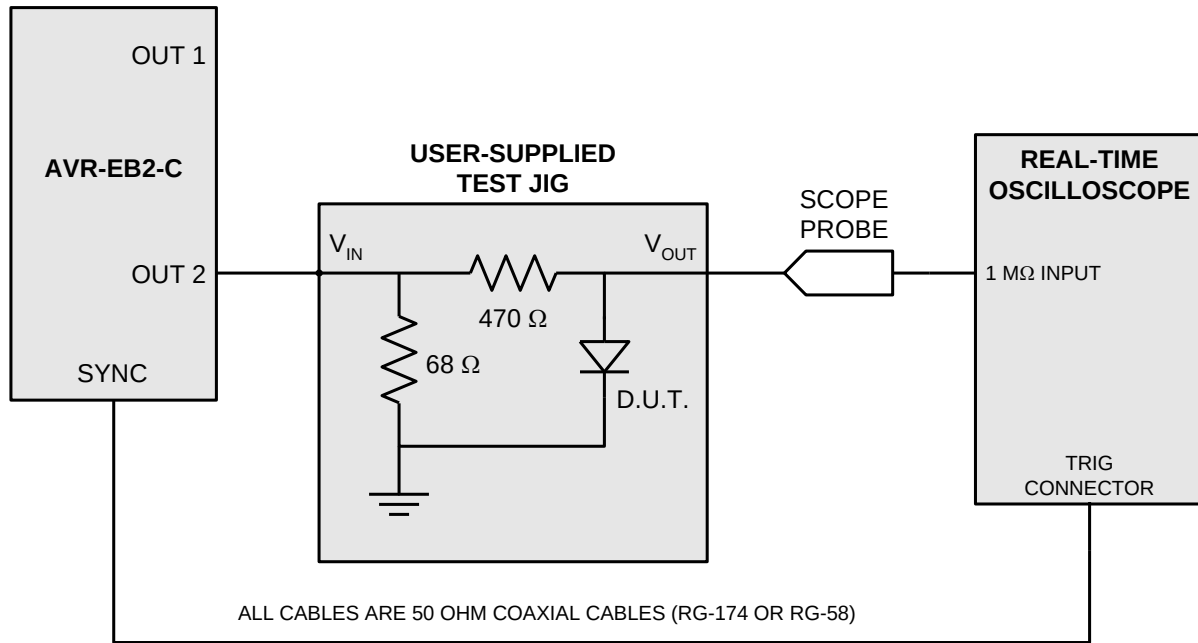

Figure E

The resulting waveforms are illustrated below:

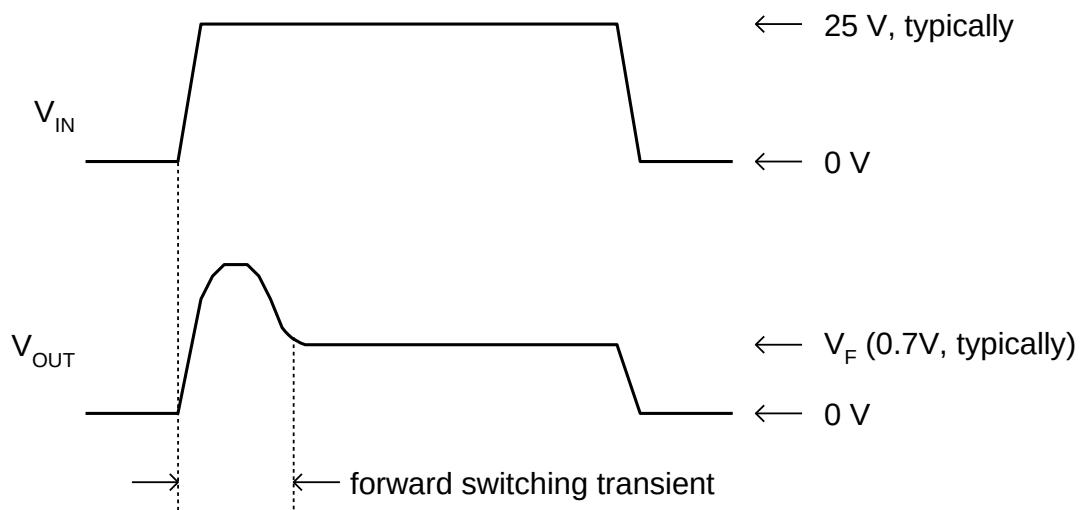
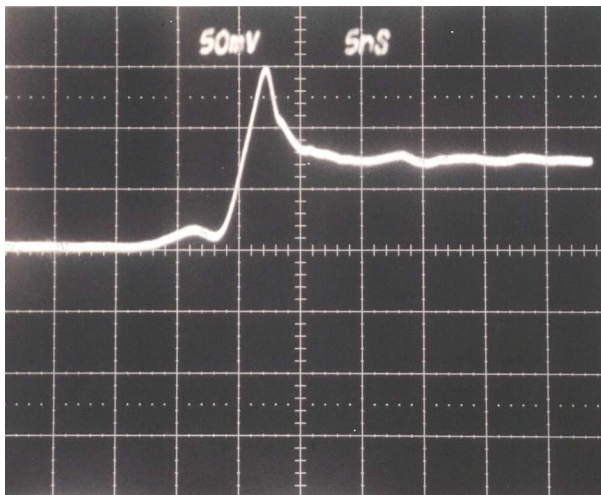

Figure F

The necessary OUT 2 amplitude, V_{IN} , needed to generate a given forward current, I_F , can be calculated using: $V_{IN} = V_F + I_F \times 470 \Omega$, where V_F is the typical forward voltage drop across the diode. If higher currents are required, the 470Ω resistor can be decreased.

EXAMPLE PROCEDURE - FORWARD RECOVERY TEST WITH A 1N4150 DIODE

- 1) For this example, connect the pulser and test jig as shown in Figure D. Insert the 1N4150 diode in the D.U.T. socket.
- 2) Set the AVR-EB2-C to trigger at 10 kHz.
- 3) Set PW2 control to "0.1", corresponding to 150 ns, approximately.
- 4) Set the OUT2 amplitude control to "5.0", corresponding to +25V, approximately. (This will produce approximately +50 mA of forward current.)
- 5) Set the sampling oscilloscope time base to 5 ns/div, and the vertical scale to 100 mV/div. (The AVX-BP-2 attenuates the signal by a factor of 11, so the actual vertical scale will be 0.55 V/div.) Adjust the oscilloscope controls as required to center the waveform on the display.
- 6) The oscilloscope should show a waveform similar to that shown below:



0.55 V/div, 5 ns/div

It can be observed that the forward recovery time of the 1N4150 diode is approximately 6 ns, in this example.

PERFORMING METHOD 4031.1 REVERSE RECOVERY TESTS

The MIL-STD-750C Methods 4031.1 reverse recovery test require more skill to perform than the 4026.2 tests, because two separate signals are combined to test the diode. When performing Method 4031.1 reverse recovery tests on ultra-fast switching diodes with recovery times on the order of several tens of nanoseconds, it is necessary to use a high-speed sampling oscilloscope, as shown in Figure G:

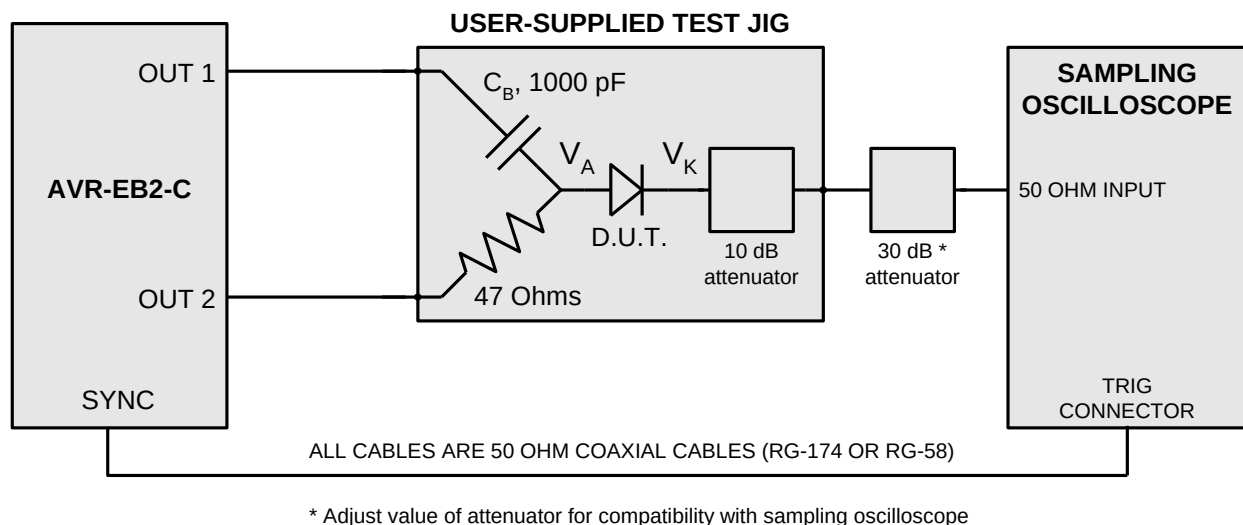

Figure G

For diodes with longer recovery times (> 100 ns), it is practical and more convenient to use a real-time oscilloscope, as shown in Figure H:

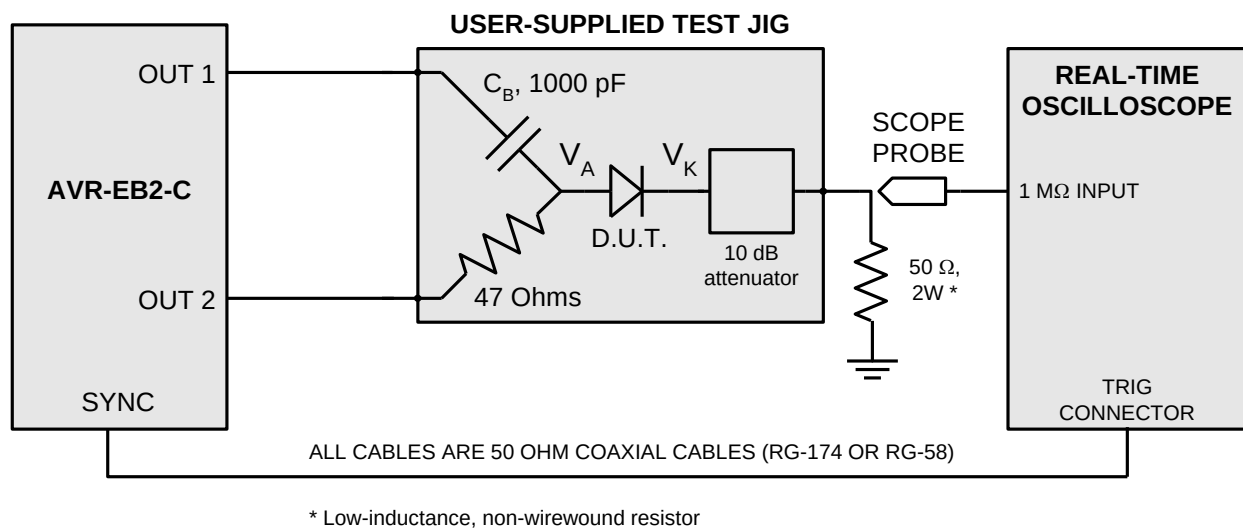

Figure H

When performing Method 4031.1 tests, the basic approach is to combine a wide positive pulse from the OUT 2 output with a narrower, delayed negative pulse from the OUT 1 output. The magnitude of the OUT 2 pulse must be larger than the magnitude of the OUT 1 pulse, to send the diode into reverse bias. The (simplified) resulting waveforms are illustrated below:

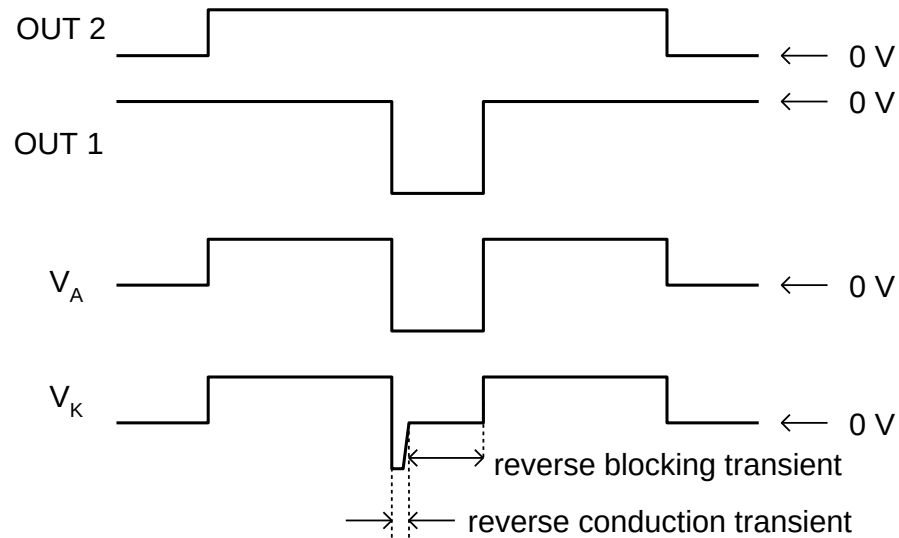

Figure I

Because of the finite value of the coupling capacitor C_B , the actual waveforms will display some AC-coupling effects (rounding and decay):

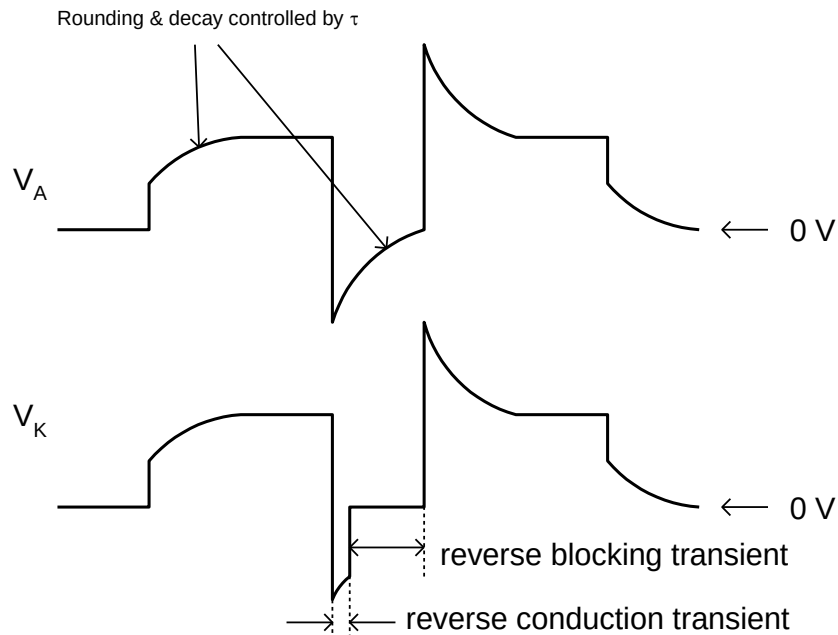

Figure J

The time constant of the rounding and decay is in the order of $\tau = 50\Omega \times C_B$. For instance, if $C_B = 1000$ pF, the time constant τ is approximately 50 ns. The negative-going pulse should be delayed at least 3τ relative to the start of the positive-going pulse. Also, τ should be several times larger than the expected duration of reverse conduction transient. If τ is too small, the negative-going pulse will decay before the reverse conduction transient has finished, and no reverse-blocking transient will be observed. This will yield incorrect measurements.

EXAMPLE PROCEDURE - REVERSE RECOVERY TEST WITH A 1N4150 DIODE

This example procedure shows results obtained with an ultra-fast, medium current switching diode, the 1N4150. Due to the ultra-fast nature of the diode, a sampling oscilloscope should be used.

- 1) Turn both AMP controls on AVR-EB2-C to minimum.
- 2) Set PW 1 control to "6.0" (corresponding to 150 ns, approximately) and PW 2 control to about 2.0 (corresponding to 1 us, approximately).
- 3) Set DELAY 1-2 to "0.7" (corresponding to 500 ns, approximately).
- 4) Set PRF to 10 kHz, approximately.
- 5) Set TRIGGER DELAY to its minimum setting, and set the ADVANCE/DELAY switch to ADVANCE.
- 6) Connect to diode test jig as shown in Fig. G.

CAUTION: Channel 1 of the pulse generator provides a rise time of 0.5 ns. Consequently, the diode test jig must be extremely broadband or the pulse rise time will be degraded and severe ringing will be observed. It is recommended that the test jig be constructed on microstrip employing high quality connectors (e.g. SMA), microwave capacitors and resistors and that the diode lead lengths be less than 0.2 cm.

- 7) Set scope time base to 50 ns/div and the vertical setting to 100 mV/div.
- 8) Increase AMP 2 to near maximum to obtain display shown in Fig. 1 (adjust DELAY and scope set-up to center the waveform display). With 30 dB attenuation following the test jig, the scope reads 10 Volts per div (or 200 mA per div). Therefore, set to two divisions to obtain $I_F = 400$ mA. Note that the coupling of OUT 2 to OUT 1 results in the increase of the rise time of OUT 2 to more than 5 ns. This is due entirely to CB in the test jig. For this reason, CB should be limited to 1000 pF. Note that with OUT 1 disconnected, the fast rise time waveform shown in Fig. 2 is obtained.

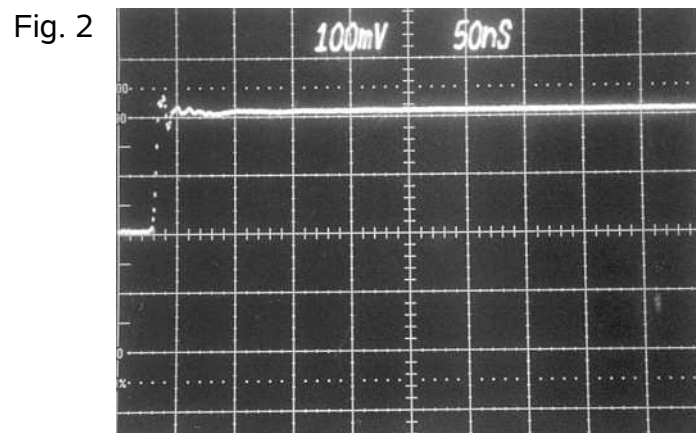
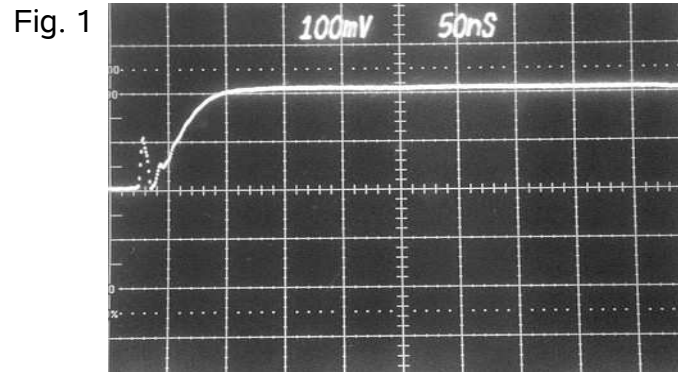

9) Increase AMP 1 to near maximum to obtain display shown in Fig. 3 (200 mA/div).

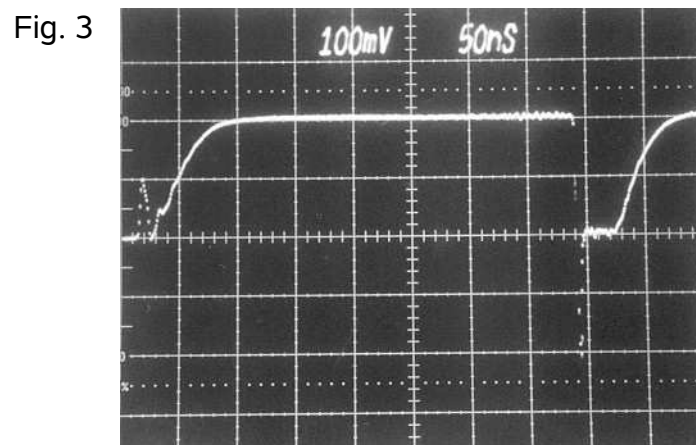

10) Set scope time base on 5 or 1 ns/div to obtain display shown in Fig. 4 and/or Fig. 5 (adjust TRIGGER DELAY to center waveform on the oscilloscope). Note that the leading spike (and ripple) on the IR waveform are primarily due to the extremely short rise time of OUT 1 and the parasitic reactance of the test jig.

Fig. 4

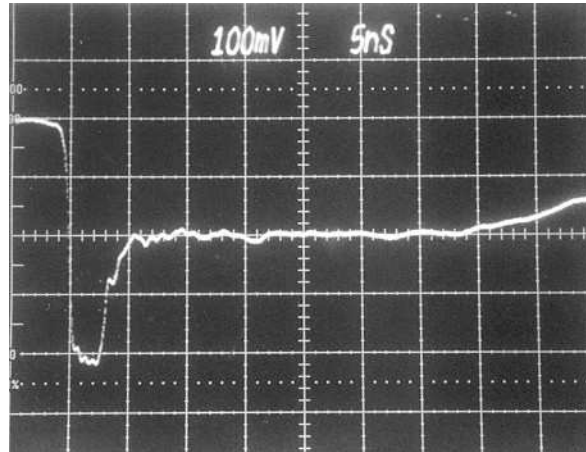
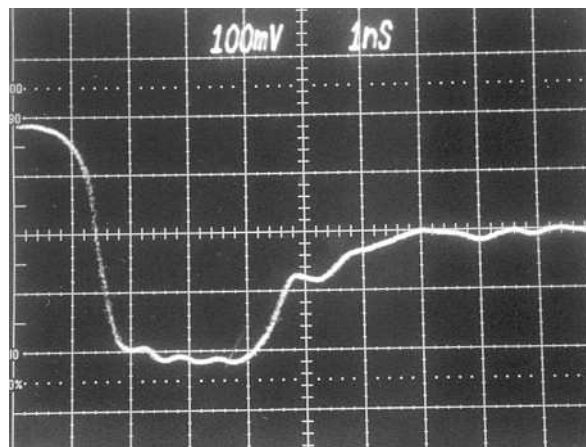

Fig. 5



- 11) Adjust AMP 1 and AMP 2 as desired to obtain final values for I_F and I_R . Note that if I_F is increased then I_R will decrease (since pulse generators are cross-connected). It is therefore necessary to increase the AMP 1 setting to return I_R to the original value.
- 12) The DELAY 1-2 control may be adjusted to re-position the leading edge of the I_R waveform with respect to the leading edge of the I_F waveform.
- 13) Note that if the PRF is set higher (eg. 20 kHz) and PW 2 is set higher (eg. 5 μ s), the apparent available maximum I_F will decrease to less than 500 mA because of the effective clamping action of the diode load under such higher duty cycle conditions. For this reason, a PRF of 10 kHz and a PW 2 of 1.0 μ s are recommended.
- 14) 1N4148: Specifications for 1N4148 call for I_R , I_F of 10 mA. It is recommended that 10 dB attenuation be placed on OUT 1 and OUT 2 and that 10 dB replace 30 dB in the output of the test jig.

USING TEST JIGS

As noted previously, channel 1 of the pulse generator provides a rise time of 0.5 ns. Consequently, the diode test jig must be extremely broadband or the pulse rise time will be degraded and severe ringing will be observed. It is recommended that the test jig be constructed on microstrip employing high quality connectors (e.g. SMA), microwave capacitors and resistors and that the diode lead lengths be less than 0.2 cm.

An example of a reverse-recovery test jig used for factory tests is shown below:

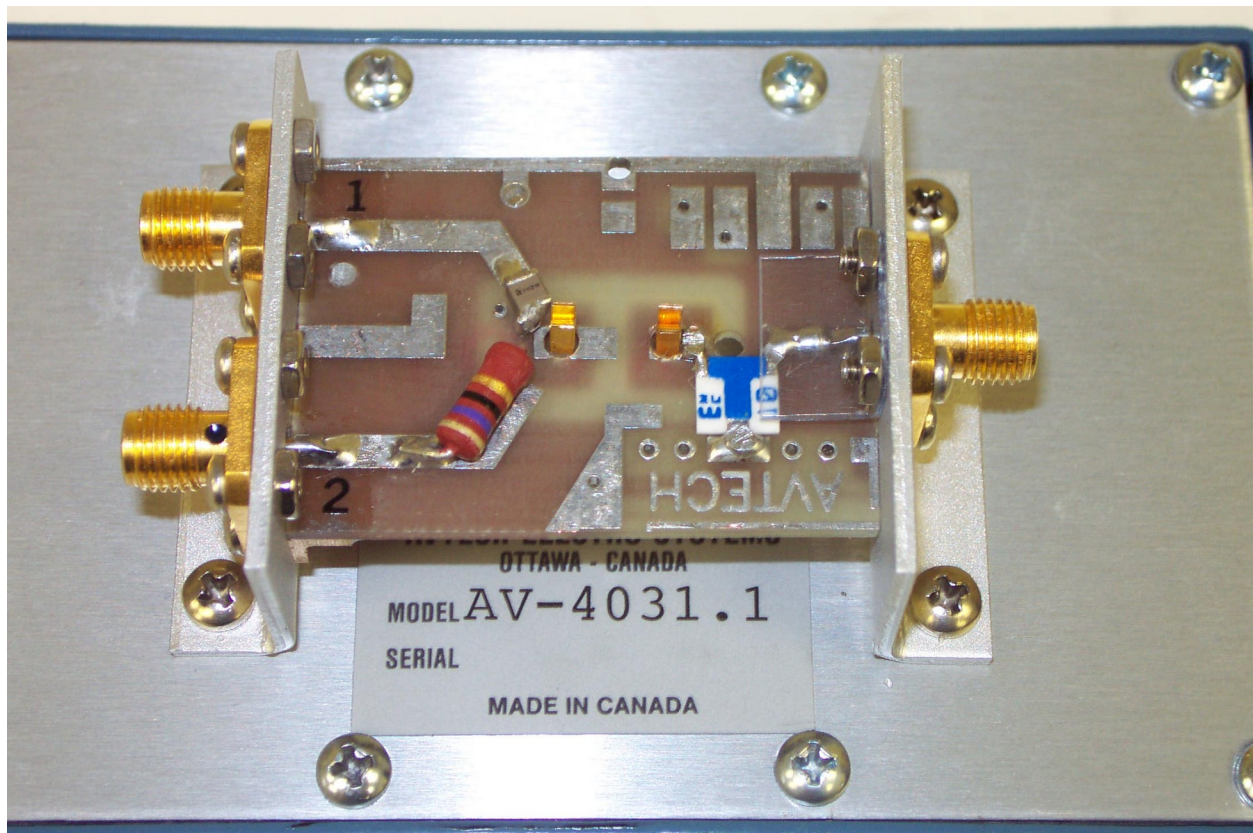

The physical layout corresponds directly to that shown in Figures G and H of the previous section. Two small clips are located in the center of the jig. The diode is normally installed between these two clips. (No diode is present in the photo.)

MECHANICAL INFORMATION

TOP COVER REMOVAL

If necessary, the interior of the instrument may be accessed by removing the four Phillips screws on the top panel. With the four screws removed, the top cover may be slid back (and off).

Always disconnect the power cord before opening the instrument.

There are no user-adjustable internal circuits. For repairs other than fuse replacement, please contact Avtech (info@avtechpulse.com) to arrange for the instrument to be returned to the factory for repair.

⚠ Caution: High voltages are present inside the instrument during normal operation. Do not operate the instrument with the cover removed.

RACK MOUNTING

A rack mounting kit is available. The -R5 rack mount kit may be installed after first removing the one Phillips screw on the side panel adjacent to the front handle.

ELECTROMAGNETIC INTERFERENCE

To prevent electromagnetic interference with other equipment, all used outputs should be connected to shielded 50Ω loads using shielded 50Ω coaxial cables. Unused outputs should be terminated with shielded 50Ω coaxial terminators or with shielded coaxial dust caps, to prevent unintentional electromagnetic radiation. All cords and cables should be less than 3m in length.

MAINTENANCE

REGULAR MAINTENANCE

This instrument does not require any regular maintenance.

On occasion, one or more of the four rear-panel fuses may require replacement. All fuses can be accessed from the rear panel. See the “FUSES” section for details.

CLEANING

If desired, the interior of the instrument may be cleaned using compressed air to dislodge any accumulated dust. (See the “TOP COVER REMOVAL” section for instructions on accessing the interior.) No other cleaning is recommended.

PERFORMANCE CHECK SHEET