



AVTECH ELECTROSYSTEMS LTD.

NANOSECOND WAVEFORM ELECTRONICS
SINCE 1975

P.O. BOX 265
OGDENSBURG, NY
U.S.A. 13669-0265

TEL: 888-670-8729 (USA & Canada) or +1-613-686-6675 (Intl)
FAX: 800-561-1970 (USA & Canada) or +1-613-686-6679 (Intl)

info@avtechpulse.com - <http://www.avtechpulse.com/>

BOX 5120, LCD MERIVALE
OTTAWA, ONTARIO
CANADA K2C 3H4

INSTRUCTIONS

MODEL AVR-EB4-B-NXPB

+0.5A / -1A REVERSE RECOVERY

MEASUREMENT SYSTEM

WITH 1.5 ns SWITCHING TIME

SERIAL NUMBER: _____

WARRANTY

Avtech Electrosystems Ltd. warrants products of its manufacture to be free from defects in material and workmanship under conditions of normal use. If, within one year after delivery to the original owner, and after prepaid return by the original owner, this Avtech product is found to be defective, Avtech shall at its option repair or replace said defective item. This warranty does not apply to units which have been disassembled, modified or subjected to conditions exceeding the applicable specifications or ratings. This warranty is the extent of the obligation assumed by Avtech with respect to this product and no other warranty or guarantee is either expressed or implied.

TECHNICAL SUPPORT

Phone: 888-670-8729 (USA & Canada) or +1-613-686-6675 (International)

Fax: 800-561-1970 (USA & Canada) or +1-613-686-6679 (International)

E-mail: info@avtechpulse.com

World Wide Web: <http://www.avtechpulse.com>

TABLE OF CONTENTS

WARRANTY.....	2
TECHNICAL SUPPORT.....	2
TABLE OF CONTENTS.....	3
INTRODUCTION.....	6
MODEL HISTORY.....	7
SPECIFICATIONS.....	8
REGULATORY NOTES.....	9
FCC PART 18.....	9
EC DECLARATION OF CONFORMITY.....	9
DIRECTIVE 2002/95/EC (RoHS).....	10
DIRECTIVE 2002/96/EC (WEEE).....	10
INSTALLATION.....	11
VISUAL CHECK.....	11
POWER RATINGS.....	11
CONNECTION TO THE POWER SUPPLY.....	11
PROTECTION FROM ELECTRIC SHOCK.....	12
ENVIRONMENTAL CONDITIONS.....	13
FUSES.....	14
AC FUSE REPLACEMENT.....	14
DC FUSE REPLACEMENT.....	15
FUSE RATINGS.....	15
FRONT PANEL CONTROLS.....	16
REAR PANEL CONTROLS.....	18
TIMING CONTROL.....	20
BASIC TIMING CONTROL.....	20
TRIGGER MODES.....	21
GATING MODES.....	21
BASIC AMPLITUDE CONTROL.....	22
SETTING THE AMPLITUDE LEVELS.....	22
AMPLITUDE ACCURACY.....	23
INCORRECT ORIENTATION.....	24
ACCESSIBLE VOLTAGES.....	24

STANDARD TEST JIG MECHANICAL ASPECTS.....	25
AVX-TRR-MIX-NXPB TEST JIG.....	25
TYPICAL RESULTS: 1N4937.....	28
SPECIALIZED / CUSTOMIZED TEST JIGS.....	32
AVX-TRR-MELF-NXPB.....	32
TYPICAL RESULTS: PMEG3020DEP115.....	33
TYPICAL RESULTS: PMEG4010ER115.....	33
TROUBLESHOOTING.....	35
PROGRAMMING YOUR PULSE GENERATOR.....	36
KEY PROGRAMMING COMMANDS.....	36
ALL PROGRAMMING COMMANDS.....	36
MECHANICAL INFORMATION.....	39
TOP COVER REMOVAL.....	39
RACK MOUNTING.....	39
ELECTROMAGNETIC INTERFERENCE.....	39
MAINTENANCE.....	40
REGULAR MAINTENANCE.....	40
CLEANING.....	40
WIRING DIAGRAMS.....	41
WIRING OF AC POWER, STYLE 1.....	41
WIRING OF AC POWER, STYLE 2.....	42
WIRING OF HIGH VOLTAGE POWER SUPPLIES.....	43
PCB 158N - LOW VOLTAGE POWER SUPPLY, 1/3.....	44
PCB 158N - LOW VOLTAGE POWER SUPPLY, 2/3.....	45
PCB 158N - LOW VOLTAGE POWER SUPPLY, 3/3.....	46
PCB 168B - HIGH VOLTAGE DC POWER SUPPLY.....	47
PCB 201A – SAFETY INTERLOCK.....	48
PCB 104D - KEYPAD / DISPLAY BOARD, 1/3.....	49
PCB 104D - KEYPAD / DISPLAY BOARD, 2/3.....	50
PCB 104D - KEYPAD / DISPLAY BOARD, 3/3.....	51
MAIN WIRING.....	52
STANDARD TEST JIG WIRING (AVX-TRR-MIX-NXPB).....	53
MELF TEST JIG WIRING (AVX-TRR-MELF-NXPB).....	54
PERFORMANCE CHECK SHEET.....	55

Last modified February 29, 2024.
Copyright © 2024 Avtech Electrosystems Ltd, All Rights Reserved.

INTRODUCTION

The AVR-EB4-B-NXPB is a high performance, GPIB and RS232-equipped instrument capable of generating a bipolar waveform into a 50 Ohm resistance. Normally, a diode will be placed in series with this resistance, allowing diode currents of up to +0.5A and -1A to be generated. When used with a user-supplied oscilloscope, this instrument is useful for measuring reverse recovery times (t_{RR}) of 8 ns to 1 us.

The AVR-EB4-B-NXPB mainframe generates two pulses internally, which are combined using a resistor/capacitor network.

A 100 us wide forward-bias pulse of $V_1 = +1$ to +120V is connected to the mainframe output through a 175 Ω resistance. With a diode DUT (with a forward voltage drop of V_{DIODE}) and another 25 Ω total resistance in the connected jig and oscilloscope, the forward bias current is given by:

$$I_F = (V_1 - V_{DIODE}) / 200\Omega, \text{ approximately} \\ +0.5A \text{ maximum, approximately}$$

80 us after the forward bias pulse starts, a 2 us wide reverse-bias pulse of $V_2 = -7.5$ to -84V is capacitively coupled to the mainframe output. This generates a current of:

$$I_R = I_F + (V_2 / 50\Omega), \text{ approximately} \\ -1A \text{ maximum, approximately}$$

The forward-to-reverse switching time is 1.2 - 1.5 ns (10%-90%) typically.

The maximum reverse voltage that will develop across the DUT is:

$$V_{RMAX} = I_R \times 50\Omega$$

The DUT breakdown voltage must exceed this value.

The AVR-EB4-B-NXPB includes one AVX-TRR-MIX-NXPB diode test jig. The instrument mainframe is connected to the test jig using two coaxial cables and one DB-9 control cable. The standard test jig contains a variety of pin sockets and posts, which may be used to hold the diode device under test (DUT). The test jig has a hinged lid, which must be fully closed to protect the user from high voltages. The output will be automatically disabled if the lid is left open. The standard AVX-TRR-MIX-NXPB test jig will accommodate TO-220AC (2 lead) packages, DO-style packages with (leads bent at 90°), and standard and reverse-polarity TO-3 packages.

The test jig output should be terminated with 50 Ohms, and connected to a high-bandwidth (> 400 MHz) oscilloscope. The voltage across this resistance is directly proportional to the current through the diode. By observing the current waveform through the diode, the reverse recovery time may be determined.

While the provided test jig is intended to be flexible and easy to use, users can also develop their own test jigs easily.

The AVR-EB4-B-NXPB may also be provided with different or additional a customized test jigs, to meet particular customer package requirements.

The AVR-EB4-B-NXPB includes an internal trigger source, but it can also be triggered or gated by an external source. A front-panel pushbutton can also be used to trigger the instrument.

The AVR-EB4-B-NXPB features front panel keyboard and adjust knob control of the output pulse parameters along with a four line by 40-character backlit LCD display of the output amplitude, pulse repetition frequency, and delay. The instrument includes memory to store up to four complete instrument setups. The operator may use the front panel or the computer interface to store a complete “snapshot” of all key instrument settings, and recall this setup at a later time.

This instrument is intended for use in research, development, test and calibration laboratories by qualified personnel.

MODEL HISTORY

Model AVR-EB4-B-NXPB S/N 12432 was converted from an earlier design, model AVR-EB4-B-NXPA.

The “-NXPB” version incorporates design changes to reduce transmission line reflections that may distort the output waveform.

SPECIFICATIONS

Model ¹ :	AVR-EB4-B-NXPB	
Recovery type:	Reverse recovery	
Intended application:	High-speed rectifiers	
Basic waveform:	A positive pulse interrupted by a negative pulse	
Pulse polarity:	-	+
Diode current ^{2,5} (approx., depends on V_{DIODE}):	-100 mA to -1 A	+50 mA to + 500 mA
Pulse width (FWHM):	2 μ s	100 μ s
Maximum duty cycle:	N/A	
Rise time (10%-90%):	1.2 - 1.5 ns typically	N/A
Maximum PRF:	1 kHz	
Delay:	80 μ s after start of + pulse	N/A
Coaxial cable to test jig (supplied):	Two 2 m / 6 feet, RG-316 or RG-58C/U cables.	
Supplied test jig ⁴ :	Model AVX-TRR-MIX-NXPB. Includes pin sockets for TO-220AC (2 lead) packages, DO-style packages ³ with leads bent at 90°, and standard and reverse-polarity TO-3 packages. Lead bending is required for axial packages.	
Mainframe connectors:	BNC	
GPIB and RS-232 control:	Standard on -B units. See http://www.avtechpulse.com/gpib for details.	
Trigger required:	Ext trig mode: + 5 Volts, 10 ns or wider (TTL)	
Gate input	Active high or low, switchable. Suppresses triggering when active.	
Power requirements:	100 - 240 Volts, 50 - 60 Hz	
Dimensions:	H x W x D: 100 mm x 430 mm x 375 mm (3.9" x 17" x 14.8")	
Chassis material:	cast aluminum frame and handles, blue vinyl on aluminum cover plates	
Temperature range:	+5°C to +40°C	

- 1) -B suffix indicates IEEE-488.2 GPIB and RS-232 control of amplitude, pulse width, PRF and delay (see <http://www.avtechpulse.com/gpib>).
- 2) For operation at amplitudes of less than 10% of full-scale, best results will be obtained by setting the amplitude near full-scale and using external attenuators on the output.
- 3) DO-15, DO-35, DO-41, DO-201AD, etc.
- 4) Customized jigs available upon request.
- 5) The amplitude settings should not be relied upon for any degree of accuracy, because the dynamics of the device under test can affect the actual generated waveforms. Amplitude settings should always be verified by oscilloscope measurements.
- 6) The diode must have a breakdown voltage exceeding these amplitude limits. Contact Avtech for special arrangements if $I_{MAX} \times 50\Omega > V_{BR}$.

REGULATORY NOTES

FCC PART 18

This device complies with part 18 of the FCC rules for non-consumer industrial, scientific and medical (ISM) equipment.

This instrument is enclosed in a rugged metal chassis and uses a filtered power entry module. The main output signal is provided on a shielded connector that is intended to be used with shielded coaxial cabling and a shielded load. Under these conditions, the interference potential of this instrument is low.

If interference is observed, check that appropriate well-shielded cabling is used on the output connectors. Contact Avtech (info@avtechpulse.com) for advice if you are unsure of the most appropriate cabling. Also, check that your load is adequately shielded. It may be necessary to enclose the load in a metal enclosure.

If any of the connectors on the instrument are unused, they should be covered with shielded metal "dust caps" to reduce the interference potential.

This instrument does not normally require regular maintenance to minimize interference potential. However, if loose hardware or connectors are noted, they should be tightened. Contact Avtech (info@avtechpulse.com) if you require assistance.

EC DECLARATION OF CONFORMITY



We Avtech Electrosystems Ltd.
 P.O. Box 5120, LCD Merivale
 Ottawa, Ontario
 Canada K2C 3H4

declare that this pulse generator meets the intent of Directive 89/336/EEC for Electromagnetic Compatibility. Compliance pertains to the following specifications as listed in the official Journal of the European Communities:

EN 50081-1 Emission

EN 50082-1 Immunity

and that this pulse generator meets the intent of the Low Voltage Directive 72/23/EEC as amended by 93/68/EEC. Compliance pertains to the following specifications as listed in the official Journal of the European Communities:

EN 61010-1:2001 Safety requirements for electrical equipment for measurement, control, and laboratory use

DIRECTIVE 2002/95/EC (RoHS)

This instrument is exempt from Directive 2002/95/EC of the European Parliament and of the Council of 27 January 2003 on the Restriction of the use of certain Hazardous Substances (RoHS) in electrical and electronic equipment. Specifically, Avtech instruments are considered "Monitoring and control instruments" (Category 9) as defined in Annex 1A of Directive 2002/96/EC. The Directive 2002/95/EC only applies to Directive 2002/96/EC categories 1-7 and 10, as stated in the "Article 2 - Scope" section of Directive 2002/95/EC.

DIRECTIVE 2002/96/EC (WEEE)

European customers who have purchased this equipment directly from Avtech will have completed a "WEEE Responsibility Agreement" form, accepting responsibility for WEEE compliance (as mandated in Directive 2002/96/EC of the European Union and local laws) on behalf of the customer, as provided for under Article 9 of Directive 2002/96/EC.

Customers who have purchased Avtech equipment through local representatives should consult with the representative to determine who has responsibility for WEEE compliance. Normally, such responsibilities will lie with the representative, unless other arrangements (under Article 9) have been made.

Requirements for WEEE compliance may include registration of products with local governments, reporting of recycling activities to local governments, and financing of recycling activities.

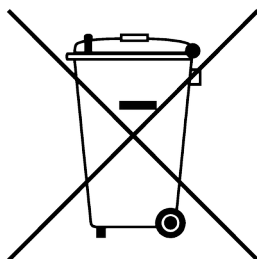

INSTALLATION

VISUAL CHECK

After unpacking the instrument, examine to ensure that it has not been damaged in shipment. Visually inspect all connectors, knobs, liquid crystal displays (LCDs), and the handles. If the instrument has been damaged, file a claim immediately with the company that transported the instrument.

The following items should be with the instrument:

1. One power cord.
2. One GPIB cable
3. Two instrumentation manuals (this manual and the “Programming Manual for -B Instruments”).
4. One test jig, with a hinged lid.
5. Two 2 m lengths of BNC-to-SMA coaxial cable. (May included an installed SMA-to-BNC adapter on one end.)
6. One 60 cm length of SMA-to-SMA coaxial cable.
7. One 2 meter DB-9 control cable.

POWER RATINGS

This instrument is intended to operate from 100 - 240 V, 50 - 60 Hz.

The maximum power consumption is 57 Watts. Please see the “FUSES” section for information about the appropriate AC and DC fuses.

This instrument is an “Installation Category II” instrument, intended for operation from a normal single-phase supply.

CONNECTION TO THE POWER SUPPLY

An IEC-320 three-pronged recessed male socket is provided on the back panel for AC power connection to the instrument. One end of the detachable power cord that is supplied with the instrument plugs into this socket. The other end of the detachable power cord plugs into the local mains supply. Use only the cable supplied with the instrument. The mains supply must be earthed, and the cord used to connect the instrument to the mains supply must provide an earth connection. (The supplied cord does this.)

 **Warning:** Failure to use a grounded outlet may result in injury or death due to electric shock. This product uses a power cord with a ground connection. It must be connected to a properly grounded outlet. The instrument chassis is connected to the ground wire in the power cord.

The table below describes the power cord that is normally supplied with this instrument, depending on the destination region:

Destination Region	Description	Option	Manufacturer	Part Number
United Kingdom, Hong Kong, Singapore, Malaysia	BS 1363, 230V, 50 Hz	-AC00	Qualtek	370001-E01
Australia, New Zealand	AS 3112:2000, 230-240V, 50 Hz	-AC01	Qualtek	374003-A01
Continental Europe, Korea, Indonesia, Russia	European CEE 7/7 "Schuko" 230V, 50 Hz	-AC02	Qualtek	364002-D01
North America, Taiwan	NEMA 5-15, 120V, 60 Hz	-AC03	Qualtek	312007-01
Switzerland	SEV 1011, 230V, 50 Hz	-AC06	Qualtek	378001-E01
South Africa, India	SABS 164-1, 220-250V, 50 Hz	-AC17	Volex	2131H 10 C3
Japan	JIS 8303, 100V, 50-60 Hz	-AC18	Qualtek	397002-01
Israel	SI 32, 220V, 50 Hz	-AC19	Qualtek	398001-01
China	GB 1002-1, 220V, 50 Hz	-AC22	Volex	2137H 10 C3

PROTECTION FROM ELECTRIC SHOCK

 Operators of this instrument must be protected from electric shock at all times. The owner must ensure that operators are prevented access and/or are insulated from every connection point. In some cases, connections must be exposed to potential human contact. Operators must be trained to protect themselves from the risk of electric shock. This instrument is intended for use by qualified personnel who recognize shock hazards and are familiar with safety precautions required to avoid possibly injury. In particular, operators should:

1. Keep exposed high-voltage wiring to an absolute minimum.
2. Wherever possible, use shielded connectors and cabling.
3. Connect and disconnect loads and cables only when the instrument is turned off.
4. Keep in mind that all cables, connectors, oscilloscope probes, and loads must have an appropriate voltage rating.

5. Do not attempt any repairs on the instrument, beyond the fuse replacement procedures described in this manual. Contact Avtech technical support (see page 2 for contact information) if the instrument requires servicing. Service is to be performed solely by qualified service personnel.

ENVIRONMENTAL CONDITIONS

This instrument is intended for use under the following conditions:

1. indoor use;
2. altitude up to 2 000 m;
3. temperature 5 °C to 40 °C;
4. maximum relative humidity 80 % for temperatures up to 31 °C decreasing linearly to 50 % relative humidity at 40 °C;
5. Mains supply voltage fluctuations up to ± 10 % of the nominal voltage;
6. no pollution or only dry, non-conductive pollution.

FUSES

This instrument contains four fuses. All are accessible from the rear-panel. Two protect the AC prime power input, and two protect the internal DC power supplies. The locations of the fuses on the rear panel are shown in the figure below:

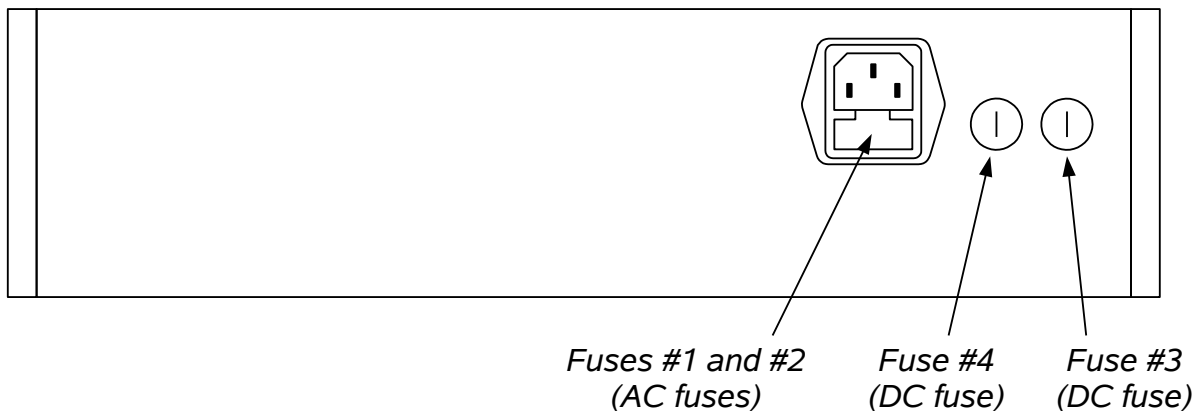

AC FUSE REPLACEMENT

To physically access the AC fuses, the power cord must be detached from the rear panel of the instrument. The fuse drawer may then be extracted using a small flat-head screwdriver, as shown below:



DC FUSE REPLACEMENT

The DC fuses may be replaced by inserting the tip of a flat-head screwdriver into the fuse holder slot, and rotating the slot counter-clockwise. The fuse and its carrier will then pop out.

FUSE RATINGS

The following table lists the required fuses:

Fuses	Nominal Mains Voltage	Rating	Case Size	Recommended Replacement Part	
				Littelfuse Part Number	Digi-Key Stock Number
#1, #2 (AC)	100-240V	0.5A, 250V, Time-Delay	5×20 mm	0218.500HXP	F2416-ND
#3 (DC)	N/A	2.0A, 250V, Time-Delay	5×20 mm	0218002.HXP	F2420-ND
#4 (DC)	N/A	1.0A, 250V, Time-Delay	5×20 mm	0218001.HXP	F2419-ND

The recommended fuse manufacturer is Littelfuse (<http://www.littelfuse.com>).

Replacement fuses may be easily obtained from Digi-Key (<http://www.digikey.com>) and other distributors.

FRONT PANEL CONTROLS

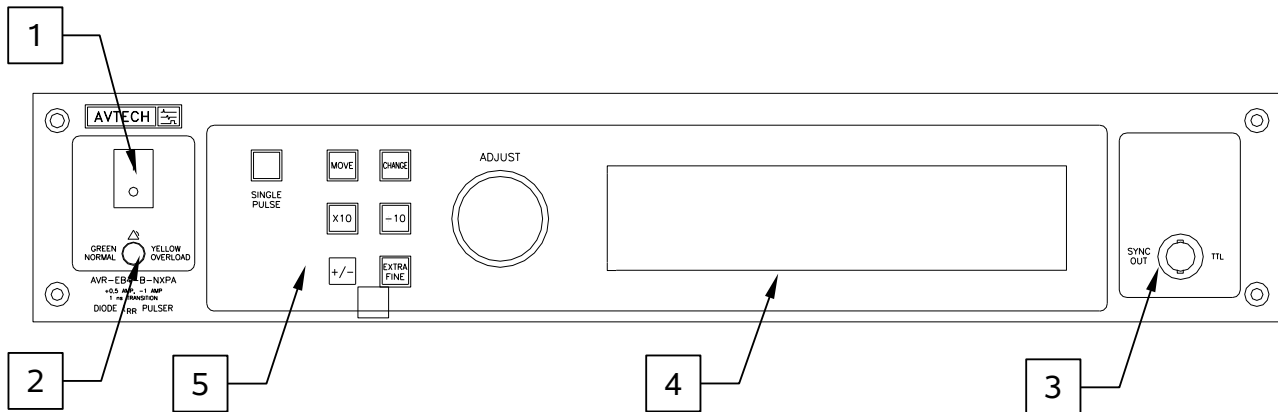

1. POWER Switch. This is the main power switch. When turning the instrument on, there may be a delay of several seconds before the instrument appears to respond.
2. OVERLOAD Indicator. When the instrument is powered, this indicator is normally green, indicating normal operation. If this indicator is yellow, an internal automatic overload protection circuit has been tripped. If the unit is overloaded (by operating at an exceedingly high duty cycle or by operating into a very low impedance), the protective circuit will disable the output of the instrument and turn the indicator light yellow. The light will stay yellow (i.e. output disabled) for about 5 seconds after which the instrument will attempt to re-enable the output (i.e. light green) for about 1 second. If the overload condition persists, the output will be disabled again (i.e. light yellow) for another 5 seconds. If the overload condition has been removed, the instrument will resume normal operation.

This overload indicator may flash yellow briefly at start-up. This is not a cause for concern.
3. SYNC OUT. This connector supplies a SYNC output that can be used to trigger other equipment, particularly oscilloscopes. This signal leads (or lags) the main output by a duration set by the "DELAY" controls and has an approximate amplitude of +3 Volts to $R_L > 50\Omega$ with a pulse width of approximately 100 ns.
4. LIQUID CRYSTAL DISPLAY (LCD). This LCD is used in conjunction with the keypad to change the instrument settings. Normally, the main menu is displayed, which lists the key adjustable parameters and their current values. The "Programming Manual for -B Instruments" describes the menus and submenus in detail.

5. KEYPAD.

Control Name	Function
MOVE	This moves the arrow pointer on the display.
CHANGE	This is used to enter the submenu, or to select the operating mode, pointed to by the arrow pointer.
×10	If one of the adjustable numeric parameters is displayed, this increases the setting by a factor of ten.
÷10	If one of the adjustable numeric parameters is displayed, this decreases the setting by a factor of ten.
+/-	If one of the adjustable numeric parameters is displayed, and this parameter can be both positive or negative, this changes the sign of the parameter.
EXTRA FINE	This changes the step size of the ADJUST knob. In the extra-fine mode, the step size is twenty times finer than in the normal mode. This button switches between the two step sizes.
ADJUST	This large knob adjusts the value of any displayed numeric adjustable values, such as frequency, pulse width, etc. The adjust step size is set by the "EXTRA FINE" button. When the main menu is displayed, this knob can be used to move the arrow pointer.

REAR PANEL CONTROLS

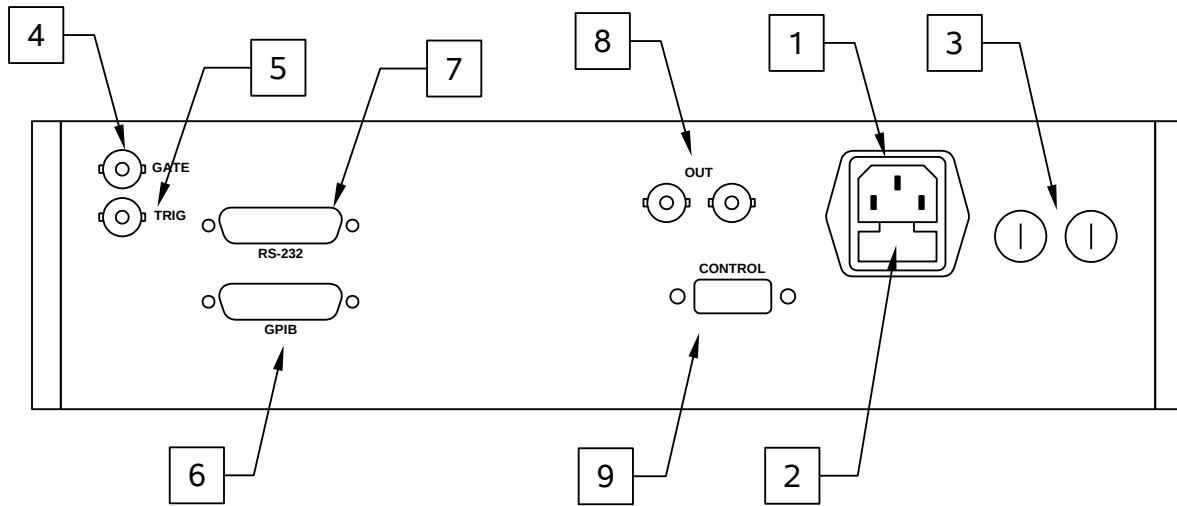

1. AC POWER INPUT. An IEC-320 C14 three-pronged recessed male socket is provided on the back panel for AC power connection to the instrument. One end of the detachable power cord that is supplied with the instrument plugs into this socket.
2. AC FUSE DRAWER. The two fuses that protect the AC input are located in this drawer. Please see the “FUSES” section of this manual for more information.
3. DC FUSES. These two fuses protect the internal DC power supplies. Please see the “FUSES” sections of this manual for more information.
4. GATE. This TTL-level (0 and +5V) logic input can be used to gate the triggering of the instrument. This input can be either active high or active low, depending on the front panel settings or programming commands. (The instrument triggers normally when this input is unconnected). When set to active high mode, this input is pulled-down to ground by a 1 k Ω resistor. When set to active low mode, this input is pulled-up to +5V by a 1 k Ω resistor.
5. TRIG. This TTL-level (0 and +5V) logic input can be used to trigger the instrument, if the instrument is set to triggering externally. The instrument triggers on the rising edge of this input. The input impedance of this input is 1 k Ω . (Depending on the length of cable attached to this input, and the source driving it, it may be desirable to add a coaxial 50 Ohm terminator to this input to provide a proper transmission line termination. The Pasternack (www.pasternack.com) PE6008-50 BNC feed-thru 50 Ohm terminator is suggested for this purpose.)
6. GPIB Connector. A standard GPIB cable can be attached to this connector to allow the instrument to be computer-controlled. See the “Programming Manual for -B Instruments” for more details on GPIB control.

7. RS-232 Connector. A standard serial cable with a 25-pin male connector can be attached to this connector to allow the instrument to be computer-controlled. See the “Programming Manual for -B Instruments” for more details on RS-232 control.
8. PULSE OUT CONNECTORS. These two BNC connectors provide the pulse output signals to the test jig. Both should be connected to the corresponding inputs on the test jig using two of the the supplied coaxial cables (2 meters in length).

These connectors are wired in parallel internally. It does not matter which “OUT” connector on the mainframe is connected to which “IN” connector on the test jig.

 Caution: Voltages as high as 120V may be present on the center conductors of these output connectors. Avoid touching these conductors. Connect to these connectors using standard coaxial cables, to ensure that the center conductors are not exposed.

9. CONTROL Connector. This DB-9 female connector should be connected to the corresponding connector on the test jig using the supplied DB-9 cable. This cable contains the safety interlock signals that ensure that the test jig lid is closed. The pinout is as follows:

Pin 1 - To test jig switch 1.

Pin 2 - To test jig switch 2.

Pin 5 - Ground.

Pin 6 - To test jig switch 1.

Pin 7 - To test jig switch 2.

Pin 9 - Safety sensor power supply (+15V through 680 Ohms).

When the test jig lid is safely closed, Pin 1 is shorted to Pin 6, and Pin 2 is shorted to Pin 7.

TIMING CONTROL

BASIC TIMING CONTROL

This instrument can be triggered by its own internal clock or by an external TTL trigger signal. In either case, two output channels respond to the trigger: PULSE and SYNC.

The PULSE output is a bipolar signal that may either drive a 50 Ohm load, or the test jig described later. The positive and negative amplitudes are adjustable. The pulse widths and delays are not adjustable.

The SYNC pulse is a fixed-width TTL-level reference pulse used to trigger oscilloscopes or other measurement systems.

These pulses are illustrated below, assuming internal triggering:

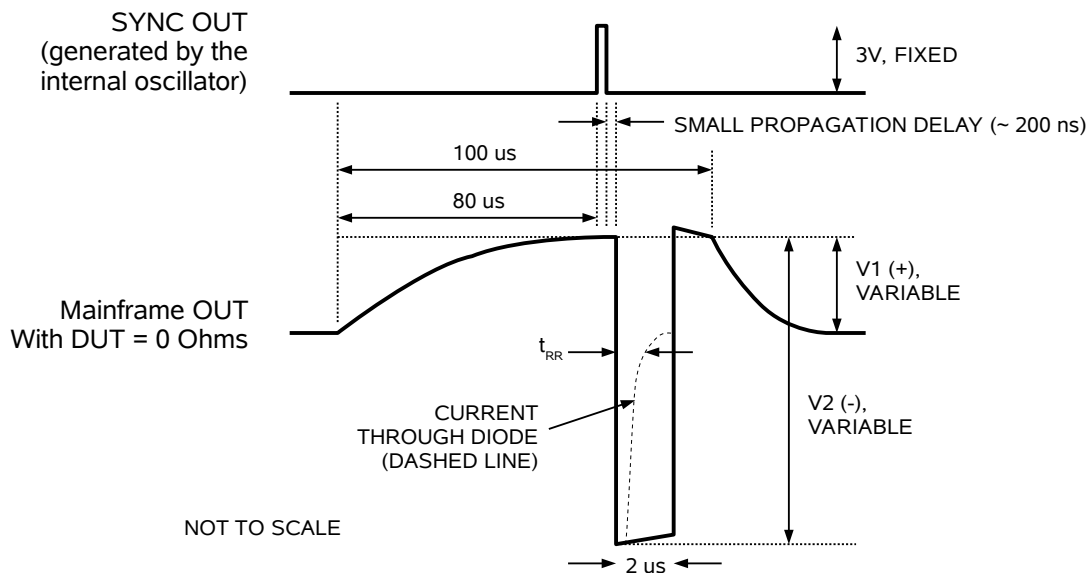

The forward-bias pulse (V_1) is approximately 100 μs wide, and has a slow rise time (governed by the $R_1 \times C_2$ time constant – see equivalent circuit in the “BASIC AMPLITUDE CONTROL” section for details about R_1 and C_2 .)

After 80 μs , V_1 has reached a stable voltage, and the SYNC output pulse is generated (to allow triggering of oscilloscopes). Shortly after the end of the SYNC pulse, the negative pulse (V_2) is triggered, and is coupled onto the output signal. The negative pulse lasts 2 μs , approximately. (V_2 droops slightly during the 2 μs time, since it is capacitively coupled to the output. However, this droop can generally be ignored.) The DUT reverse recovery transient will occur within this 2 μs time. After the end of the V_2 pulse, the waveform will complete the forward-bias pulse, but this occurs after the recovery waveform of interest has been obtained.

The pulse repetition frequency (when in the internal mode) of the output can be varied with front panel controls or via the GPIB or RS-232 computer interfaces.

The pulse width and delay settings are shown on the front panel, but they are not adjustable.

TRIGGER MODES

This instrument has four trigger modes:

- Internal Trigger: the instrument controls the trigger frequency, and generates the clock internally.
- External Trigger: the instrument is triggered by an external TTL-level clock on the back-panel TRIG connector.
- Manual Trigger: the instrument is triggered by the front-panel “SINGLE PULSE” pushbutton.
- Hold Trigger: the instrument is set to not trigger at all.

These modes can be selected using the front panel trigger menu, or by using the appropriate programming commands. (See the “Programming Manual for -B Instruments” for more details.)

GATING MODES

Triggering can be suppressed by a TTL-level signal on the rear-panel GATE connector. The instrument can be set to stop triggering when this input high or low, using the front-panel gate menu or the appropriate programming commands. When gated, the output will complete the full pulse width if the output is high, and then stop triggering. Pulses are not truncated.

BASIC AMPLITUDE CONTROL

The basic test arrangement for the AVR-EB4-B-NXPB is shown in the figure below. The PULSE output on the instrument mainframe is connected to the PULSE input on the test jig (model AVX-TRR-MIX-NXPB, or a customized variant) using the supplied coaxial cables, and the control cable is connected using the supplied DB-9 cable.

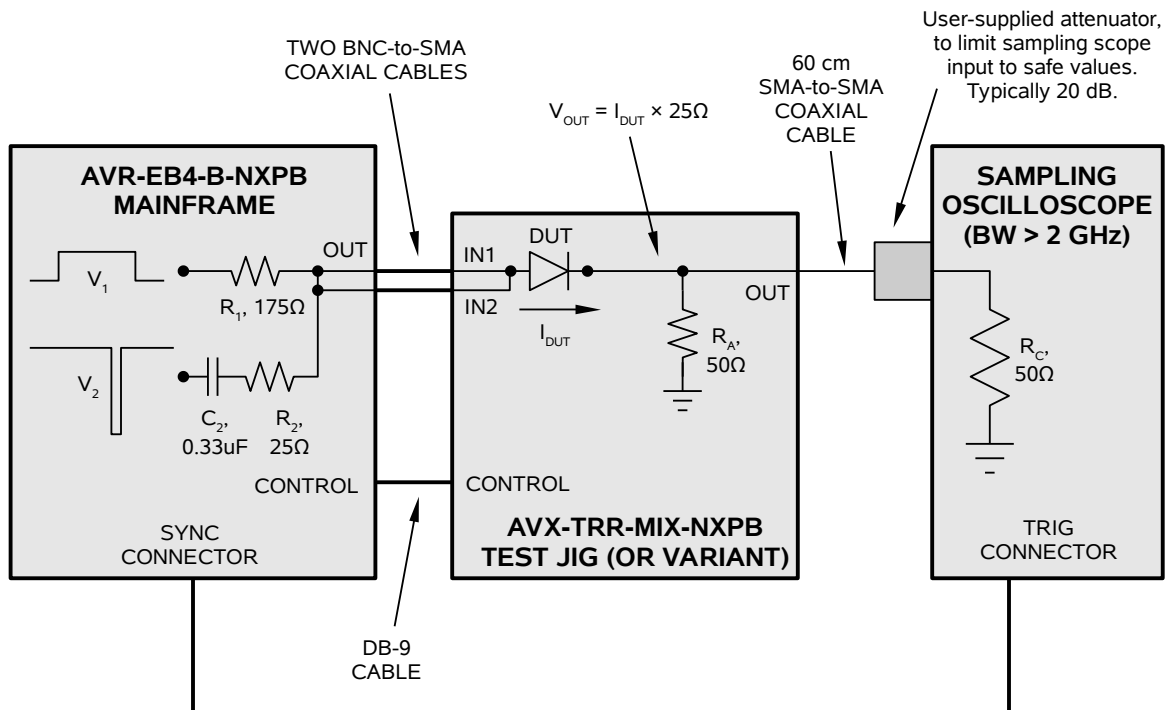

The total effective resistance of resistors R_A and R_C in the diagram above is $50\Omega / 2 = 25\Omega$. Thus, the voltage at the jig output is simply given by:

$$V_{OUT} = I_{DUT} \times (R_A \parallel R_C)$$

$$V_{OUT} = I_{DUT} \times 25 \Omega$$

where I_{DUT} is the current through the device under test. This is the key equation for relating the observed voltage waveform to the DUT current.

SETTING THE AMPLITUDE LEVELS

The amplitude of the positive and negative portions of the PULSE waveform may be set from the front panel of the instrument, or by computer command. These settings are expressed in terms of the voltage present on the test jig input.

The positive voltage V_1 ("AMP1" on the front panel display) is related to the forward diode current by:

$$I_F \approx (V_1 - V_{\text{DIODE}}) / (R_1 + (R_A \parallel R_C))$$

$$I_F \approx (V_1 - V_{\text{DIODE}}) / 200 \Omega$$

where V_{DIODE} is the forward voltage drop of the diode (typically 0.7V). The 200 Ohm resistance is the sum of R_1 in the figure above and the 25 Ohm resistance formed by R_A and R_C .

The reverse current is given by:

$$I_R \approx I_F + (V_2 / (R_2 + (R_A \parallel R_C)))$$

$$I_R \approx I_F + V_2 / 50 \Omega$$

Most test procedures for measuring recovery time will use a particular ratio of forward to reverse currents - for example, $I_{\text{REVERSE}} / I_{\text{FORWARD}} = -2$. Some Schottky diodes have negligible amounts of stored charge resulting from the forward bias, compared to non-Schottky devices. For these Schottky diodes, the reverse transient will be governed by the capacitance of the device, and the reverse transient may be largely unaffected by the amplitude of the forward transient. (In other words, the $I_{\text{REVERSE}} / I_{\text{FORWARD}}$ ratio is irrelevant). The capacitance may be so small that it becomes impossible to obtain the full -1 Amps of reverse current.

V_1 may be set between +1V and +120V.

V_2 may be set between -7.5V and -84V.

AMPLITUDE ACCURACY

Due to the variations in V_F and the diode parasitic resistance as a function of operating conditions, the V_1 (AMP1) and V_2 (AMP2) settings *should not be relied upon for any degree of accuracy – especially V_1* . Instead the voltage at the OUT terminal on the test jig should be monitored with a calibrated oscilloscope. As mentioned above,

$$V_{\text{OUT}} = I_{\text{DUT}} \times (R_A \parallel R_C)$$

R_A can be measured directly on the test jig (with the test jig disconnected) to determine calibrated relationships, if desired. R_C is provided by the user, and can be calibrated as required.

INCORRECT ORIENTATION

The instrument and the DUT will not be damaged if the diode is installed with the incorrect orientation (i.e., with the anode and cathode reversed). However, incorrect waveforms will be generated.

ACCESSIBLE VOLTAGES

The mainframe provides pulsed voltages of up to +120V or -84V to the test jig. For this reason, the output is automatically disabled when the test jig lid is open. The lid must be closed to obtain measurements.

 Shielded cabling should be used for all connections to the "IN" and "OUT" terminals on the test jig, and the "OUT" connector on the mainframe.

STANDARD TEST JIG MECHANICAL ASPECTS

One AVX-TRR-MIX-NXPB test jig is normally supplied with the mainframe, unless the customer has requested a different or additional test jigs.

AVX-TRR-MIX-NXPB TEST JIG

The AVX-TRR-MIX-NXPB test jig accepts a range of through-hole and axial devices, using pin sockets and spring-loaded pins. It is intended for use with diodes in DO-41, TO-220, DO-204AR, TO-3 or similar packages. A photo of the arrangement is shown below:

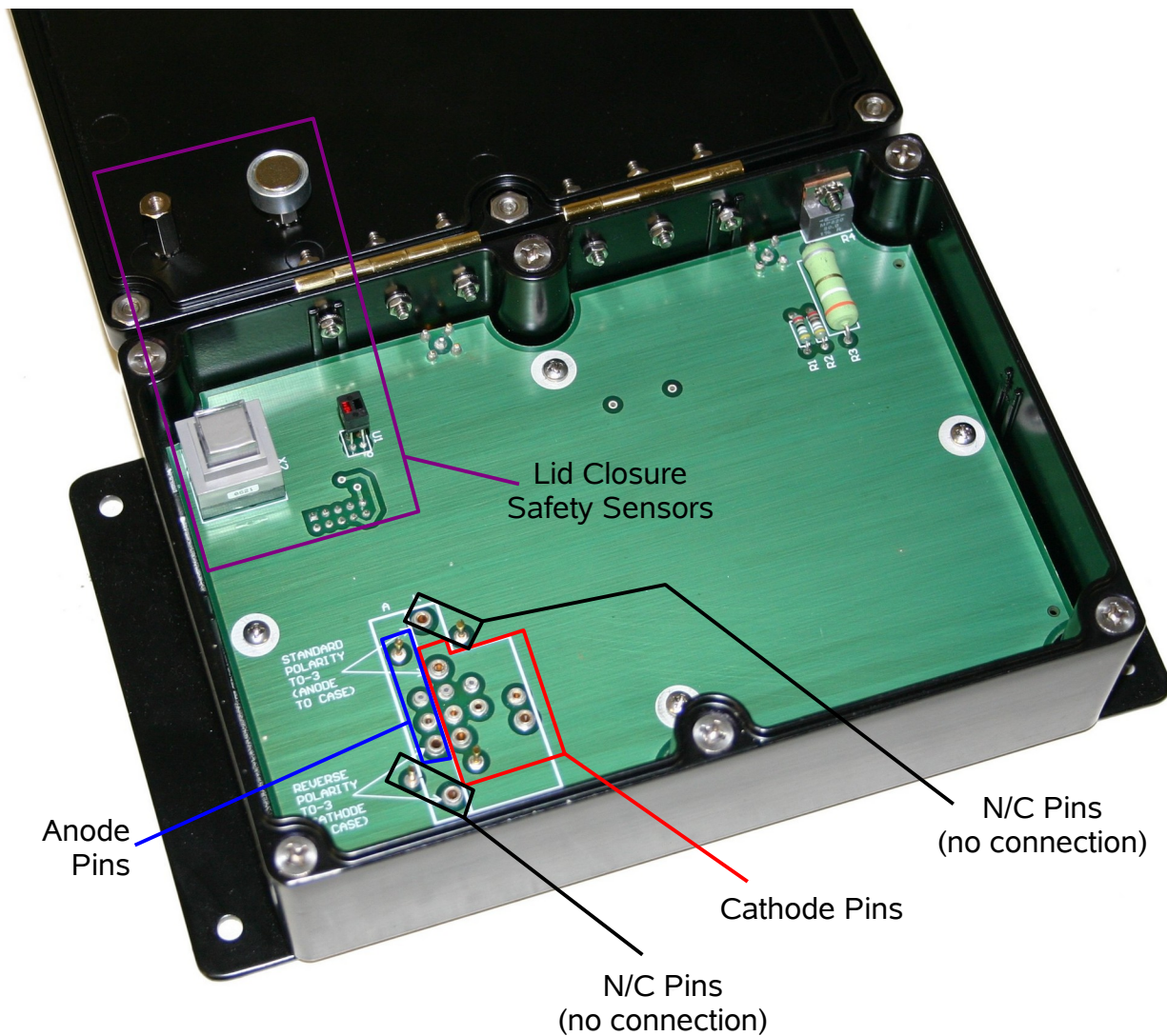

The instrument and the DUT will not be damaged if the diode is installed with the incorrect orientation (i.e., with the anode and cathode reversed). However, incorrect waveforms will be generated.

The procedure for inserting most axial and TO-220 packages is straightforward. Simply insert the DUT between one of the Anode pin sockets (in the blue area above) and one of the Cathode sockets (in the red area above). Select the sockets with the most appropriate hole size, and try to minimize all lead lengths, to minimize parasitic inductance.

This jig will also accommodate a number of TO-3 configurations, outlined below. If the case is connected to the anode, and the pin(s) are used for the cathode, the arrangement shown below must be used:

This socket and spring pin provide mechanical support only. They are not electrically active.

This spring pin must contact the underside of the case. It provides the anode connection.

The cathode pin of interest must be inserted into this socket. For dual-diode devices, rotate the TO-3 package so that the desired diode cathode is inserted here.

***For TO-3 packages
with Case = Anode***

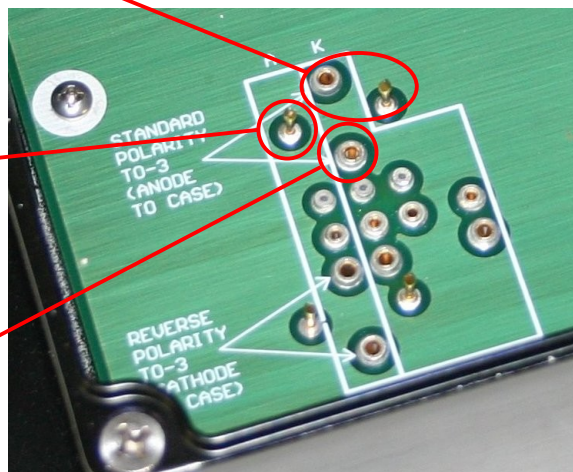

If the case is connected to the cathode, and the pin(s) are used for the anode, the arrangement shown below must be used:

**For TO-3 packages
with Case = Cathode**

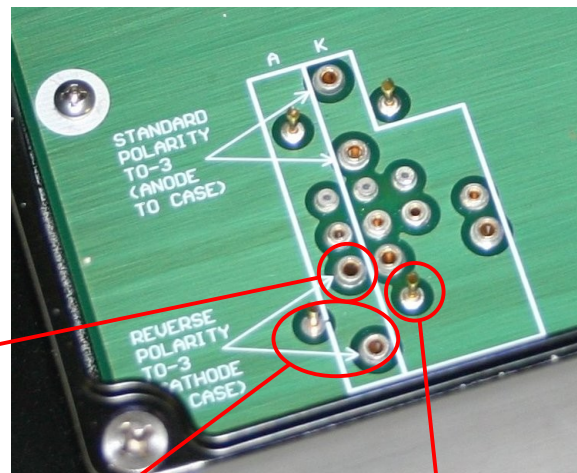

The anode pin of interest must be inserted into this socket. For dual-diode devices, rotate the TO-3 package so that the desired diode anode is inserted here.

This socket and spring pin provide mechanical support only. They are not electrically active.

This spring pin must contact the underside of the case. It provides the cathode connection.

The IN 1, IN 2, OUT, and CONTROL connectors are on the rear of the jig, below the hinges:



The IN 1 and IN 2 connectors are interchangeable. Both must be used, to connect to the two OUT connectors on the rear panel of the mainframe.

TYPICAL RESULTS: 1N4937

Obtaining meaningful results with the AVR-EB4-B-NXPB requires care, experience, and an understanding of diode transient behavior and the impact of inductive and capacitive parasitics. To assist the user, typical results for commercially available diodes are provided below. The user should be able to reliably duplicate these results.

The On Semiconductor 1N4937 is a 1A, 600V DO-41 fast-recovery rectifier. With the amplitudes set to +102V and -82.5V, actual DUT current of +0.5A and -1A observed. The full waveform (approximately 100 us wide) is shown below. The reverse transient occurs 80 us after the start of the positive-going pulse.

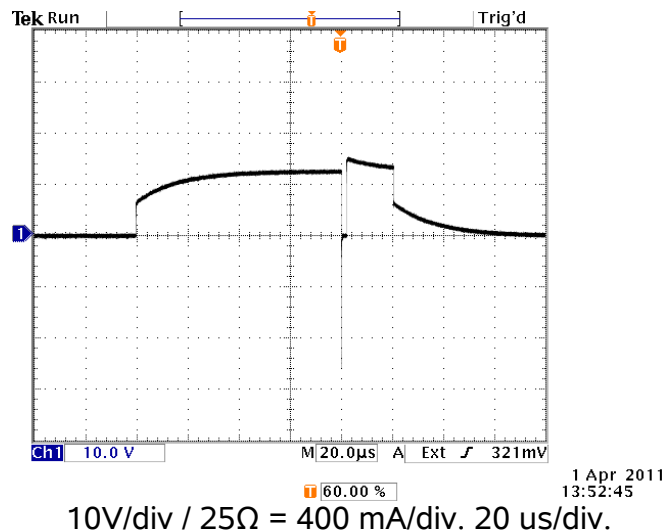

The SYNC pulse occurs shortly before the beginning of the reverse pulse. (The SYNC pulse is used to trigger the oscilloscope, and the location of the rising edge of the SYNC pulse is denoted by the orange “T” marker in the waveform above.) Changing the time scale to zoom in on the 2 us wide reverse pulse gives:

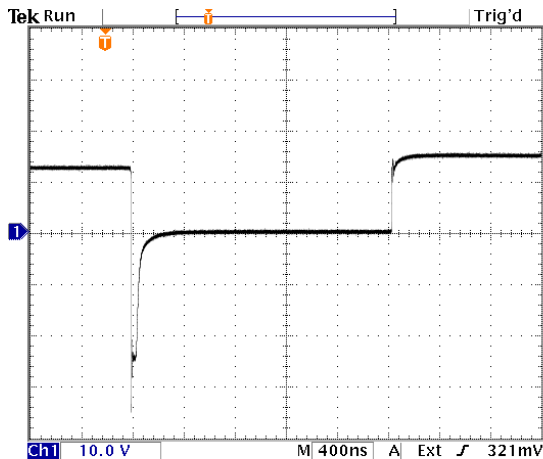

1 Apr 2011
13:53:13

$$2\text{V/div} / 5\Omega = 400 \text{ mA/div. } 400 \text{ ns/div.}$$

The reverse recovery transient is clearly visible now. Zooming in further (with a very-high bandwidth oscilloscope) gives:

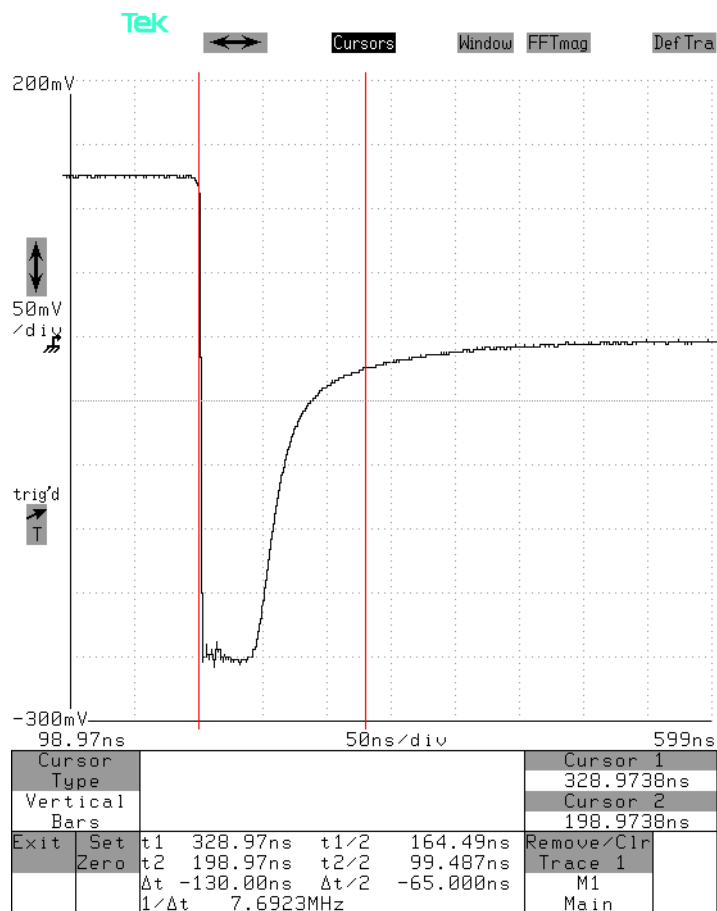

$$50 \text{ mV/div} \times 40 \text{ dB} / 25\Omega = 200 \text{ mA/div. } 50 \text{ ns/div.}$$

The t_{RR} recovery time to 10% of I_{RMAX} was measured to be 130 ns.

To verify the < 1 ns switching timing, we zoom in further:

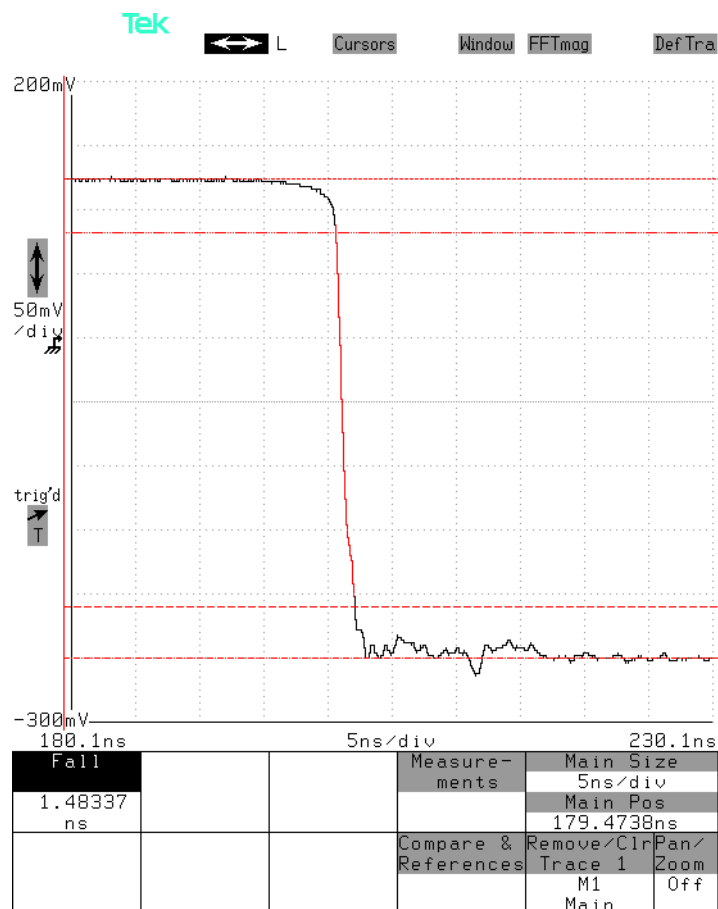

This waveform shows that the $+0.5A$ to $-1A$ switching time (10%-90%) is 1.5 ns. For lower currents, the switching time will be slightly faster.

For this test, the 1N4937 was installed as shown below:

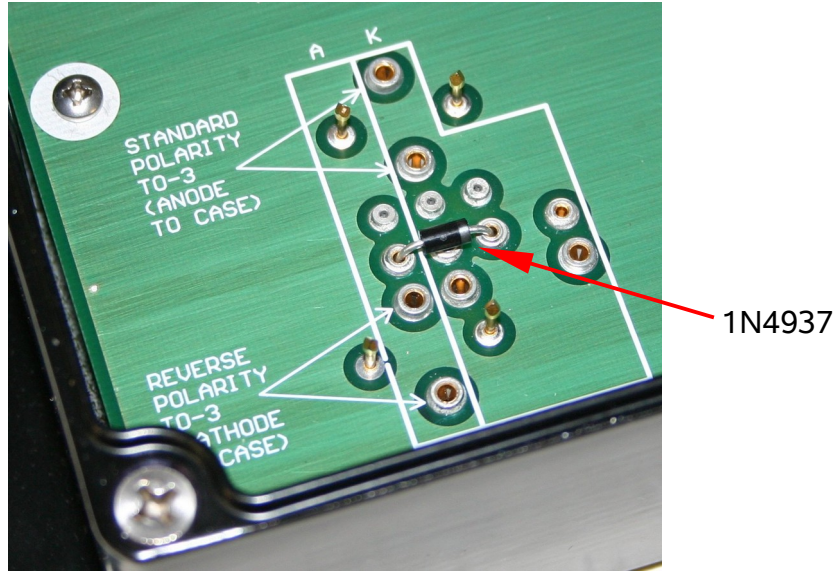

SPECIALIZED / CUSTOMIZED TEST JIGS

AVX-TRR-MELF-NXPB

The special-order AVX-TRR-MELF-NXPB may be used with the AVR-EB4-B-NXPB. This test jig is similar to the standard AVX-TFR-MIX jig described in the previous section, except that it is intended for use with SOD123W, SOD128, SOD123F, SOD323F, and similar surface-mount packages. The DUT is installed, using tweezers, between the two opposing flat-headed spring pins. For test purposes, it is best to install the DUT so that the flat leads are perpendicular to the circuit board, rather than parallel to it. This makes it easier to position the DUT with tweezers, and makes it easier to verify that the spring pin heads are making contact with the leads. A photo of an installed DUT is shown below:

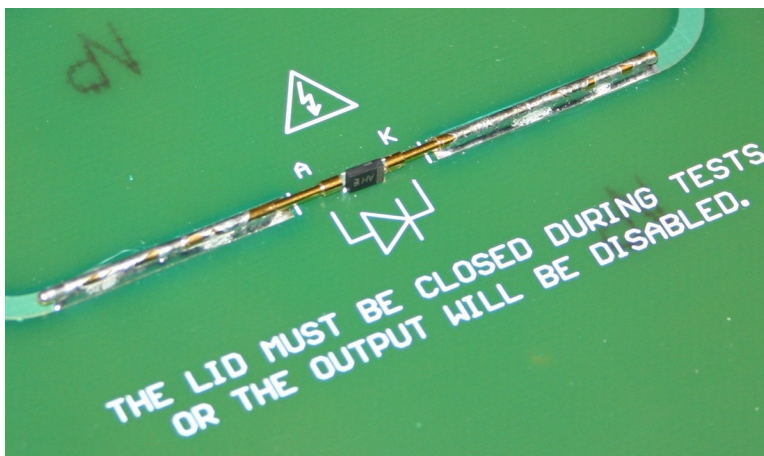

The full test jig is shown below:



TYPICAL RESULTS: PMEG3020DEP115

The NXP PMEG3020DEP115 is a surface-mounted 30V, 2A Schottky diode rectifier. It was installed in the AVX-TRR-MELF-NXPB as shown above.

Setting $V_1 = +20.8\text{V}$ and $V_2 = -17\text{V}$ gives $I_F = +100\text{mA}$ and $I_R = -200\text{mA}$. Under these conditions, the following waveform was obtained:

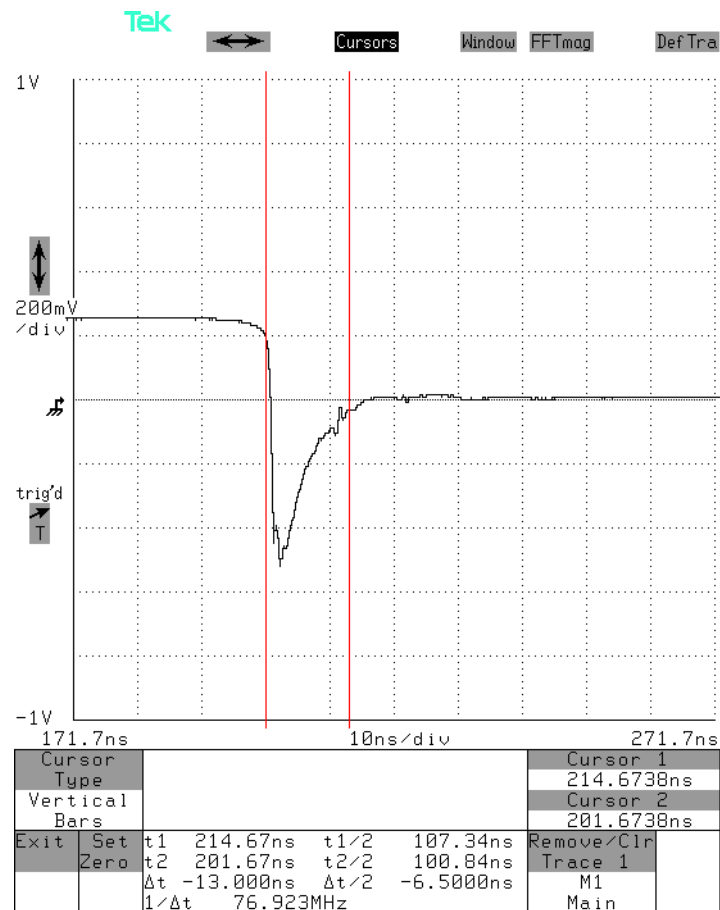

Under these conditions, $t_{RR} = 13\text{ ns}$.

TYPICAL RESULTS: PMEG4010ER115

The NXP PMEG4010ER115 is a surface-mounted 40V, 1A Schottky diode rectifier. It was installed in the AVX-TRR-MELF-NXPB as shown above.

Setting $V_1 = +40\text{V}$ and $V_2 = -36.4\text{V}$ gives $I_F = +200\text{mA}$ and $I_R = -400\text{mA}$. Under these conditions, the following waveform was obtained:

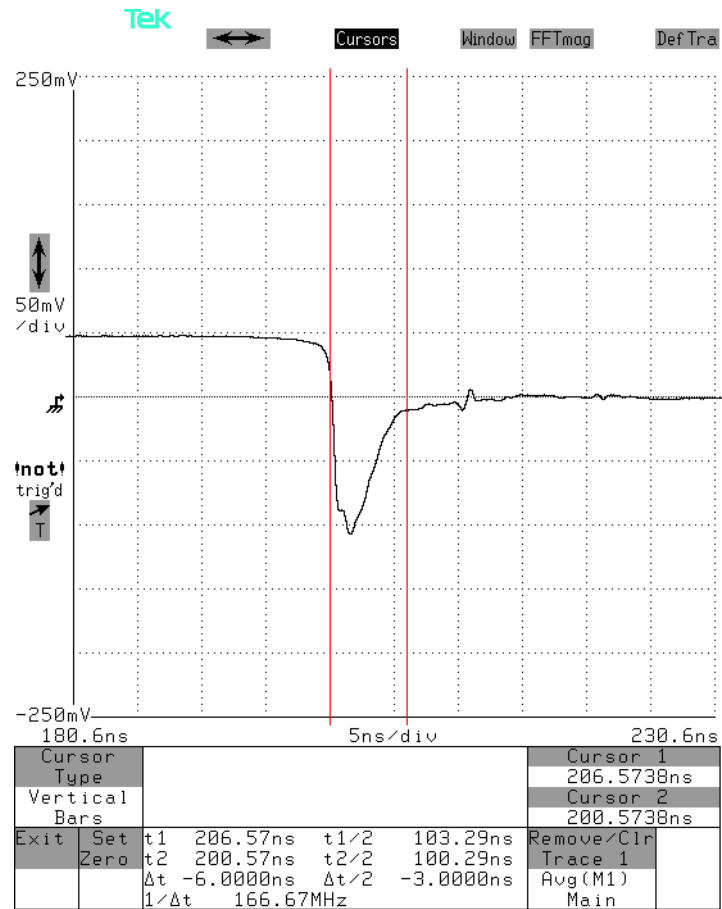

Under these conditions, $t_{RR} = 6 \text{ ns}$.

TROUBLESHOOTING

If you obtain “strange” output waveforms, or unexpected values of t_{RR} , keep these points in mind:

- 1) The test jig output *must* be terminated with 50 Ohms.
- 2) The two coaxial cables connecting the test jig to the output module should normally be 2 meters in length.
- 3) Keep device lead lengths as short as possible, to minimize parasitic inductance.
- 4) The test jig lid must be closed, or the pulser output will be disabled.

For technical support, contact info@avtechpulse.com. Sample waveforms and digital photos of your setup are always helpful!

PROGRAMMING YOUR PULSE GENERATOR

KEY PROGRAMMING COMMANDS

The “Programming Manual for -B Instruments” describes in detail how to connect the pulse generator to your computer, and the programming commands themselves. A large number of commands are available; however, normally you will only need a few of these. Here is a basic sample sequence of commands that might be sent to the instrument after power-up:

*rst	(resets the instrument)
trigger:source internal	(selects internal triggering)
frequency 1000 Hz	(sets the frequency to 1000 Hz)
volt:amp1 +20	(sets the positive pulse amplitude to +20 V)
volt:amp2 -30	(sets the negative pulse amplitude to -30 V)
output on	(turns on the output)

For triggering a single event, this sequence would be more appropriate:

*rst	(resets the instrument)
trigger:source hold	(turns off all triggering)
output on	(turns on the output)
volt:amp1 +20	(sets the positive pulse amplitude to +20 V)
volt:amp2 -30	(sets the negative pulse amplitude to -30 V)
trigger:source immediate	(generates a single non-repetitive trigger event)
trigger:source hold	(turns off all triggering)
output off	(turns off the output)

To set the instrument to trigger from an external TTL signal applied to the rear-panel TRIG connector, use:

*rst	(resets the instrument)
trigger:source external	(selects external triggering)
volt:amp1 +20	(sets the positive pulse amplitude to +20 V)
volt:amp2 -30	(sets the negative pulse amplitude to -30 V)
output on	(turns on the output)

These commands will satisfy 90% of your programming needs.

ALL PROGRAMMING COMMANDS

For more advanced programmers, a complete list of the available commands is given below. These commands are described in detail in the “Programming Manual for -B

Instruments". (Note: this manual also includes some commands that are not implemented in this instrument. They can be ignored.)

<u>Keyword</u>	<u>Parameter</u>	<u>Notes</u>
LOCAL		
OUTPut:		
:[STATe]	<boolean value>	
:PROTection		
:TRIPped?		[query only]
REMOTE		
[SOURce]:		
:FREQuency		
[:CW FIXed]	<numeric value>	
[SOURce]:		
:PULSe		
:PERiod	<numeric value>	
:WIDTh	<numeric value>	
:DELay	<numeric value>	
:GATE		
:LEVel	High Low	
[SOURce]:		
:VOLTage		
[:LEVel]		
[:IMMediate]		
[:AMPLitude]	<numeric value>	
:PROTection		
:TRIPped?		[query only]
STATUS:		
:OPERation		
:[EVENT]?		[query only, always returns "0"]
:CONDition?		[query only, always returns "0"]
:ENABle	<numeric value>	[implemented but not useful]
:QUESTionable		
:[EVENT]?		[query only, always returns "0"]
:CONDition?		[query only, always returns "0"]
:ENABle	<numeric value>	[implemented but not useful]
SYSTem:		
:COMMunicate		
:GPIB		
:ADDRes	<numeric value>	
:SERial		
:CONTRol		
:RTS	ON IBFull RFR	
:[RECeive]		
:BAUD	1200 2400 4800 9600	
:BITS	7 8	
:ECHO	<boolean value>	
:PARity		
:[TYPE]	EVEN ODD NONE	
:SBITS	1 2	
:ERRor		
:[NEXT]?		[query only]
:COUNT?		[query only]
:VERSion?		[query only]
TRIGger:		
:SOURce	INTernal EXTernal MANual HOLD IMMEDIATE	

*CLS		[no query form]
*ESE	<numeric value>	
*ESR?		[query only]
*IDN?		[query only]
*OPC		
*SAV	0 1 2 3	[no query form]
*RCL	0 1 2 3	[no query form]
*RST		[no query form]
*SRE	<numeric value>	
*STB?		[query only]
*TST?		[query only]
*WAI		[no query form]

MECHANICAL INFORMATION

TOP COVER REMOVAL

If necessary, the interior of the instrument may be accessed by removing the four Phillips screws on the top panel. With the four screws removed, the top cover may be slid back (and off).

 Always disconnect the power cord and allow the instrument to sit unpowered for 10 minutes before opening the instrument. This will allow any internal stored charge to discharge.

There are no user-adjustable internal circuits. For repairs other than fuse replacement, please contact Avtech (info@avtechpulse.com) to arrange for the instrument to be returned to the factory for repair. Service is to be performed solely by qualified service personnel.

 Caution: High voltages are present inside the instrument during normal operation. Do not operate the instrument with the cover removed.

RACK MOUNTING

A rack mounting kit is available. The -R5 rack mount kit may be installed after first removing the one Phillips screw on the side panel adjacent to the front handle.

ELECTROMAGNETIC INTERFERENCE

To prevent electromagnetic interference with other equipment, all used outputs should be connected to shielded loads using shielded coaxial cables. Unused outputs should be terminated with shielded coaxial terminators or with shielded coaxial dust caps, to prevent unintentional electromagnetic radiation. All cords and cables should be less than 3m in length.

MAINTENANCE

REGULAR MAINTENANCE

This instrument does not require any regular maintenance.

On occasion, one or more of the four rear-panel fuses may require replacement. All fuses can be accessed from the rear panel. See the “FUSES” section for details.

CLEANING

If desired, the interior of the instrument may be cleaned using compressed air to dislodge any accumulated dust. (See the “TOP COVER REMOVAL” section for instructions on accessing the interior.) No other cleaning is recommended.

WIRING DIAGRAMS

WIRING OF AC POWER, STYLE 1

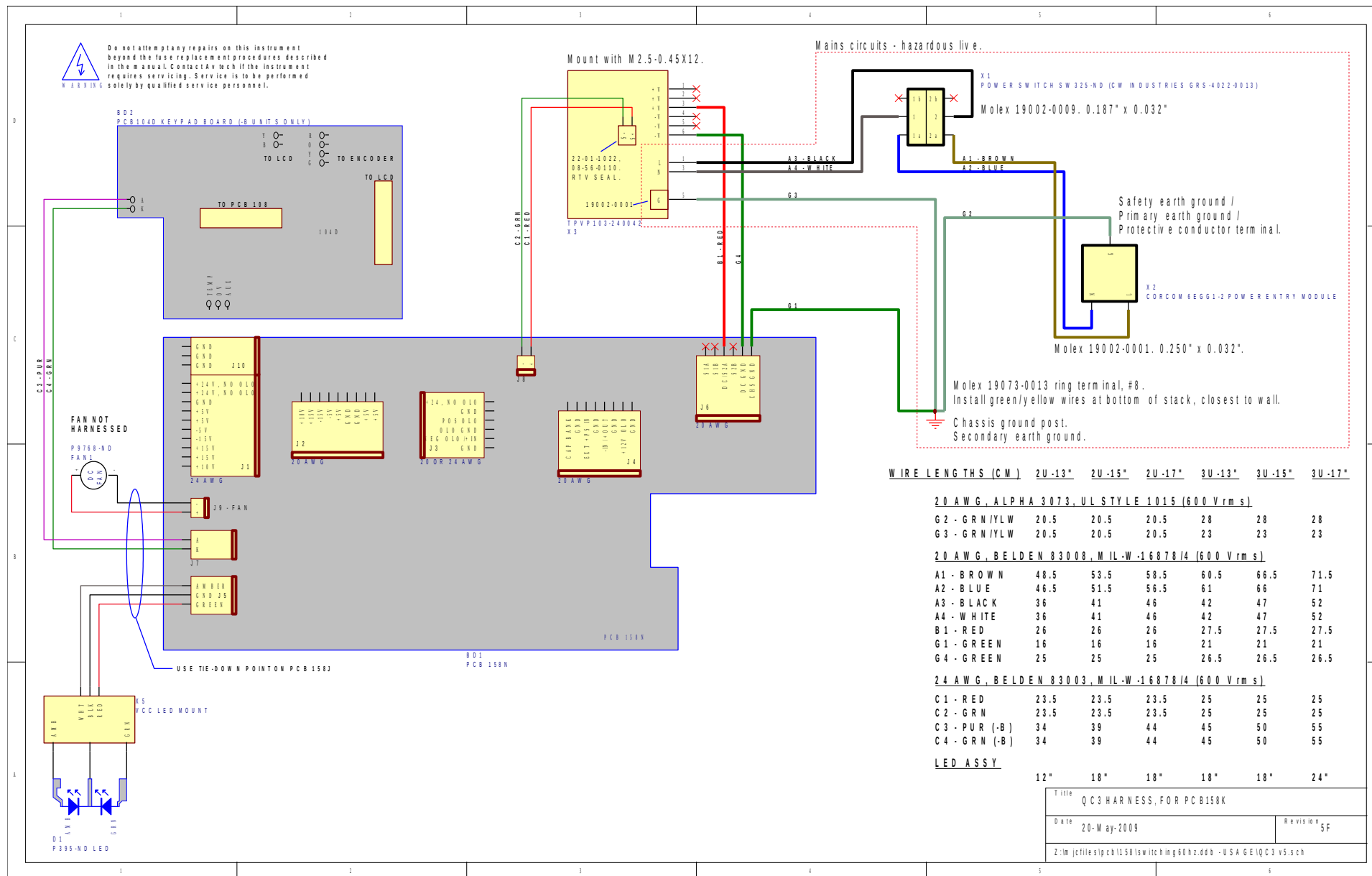

WIRING OF AC POWER, STYLE 2

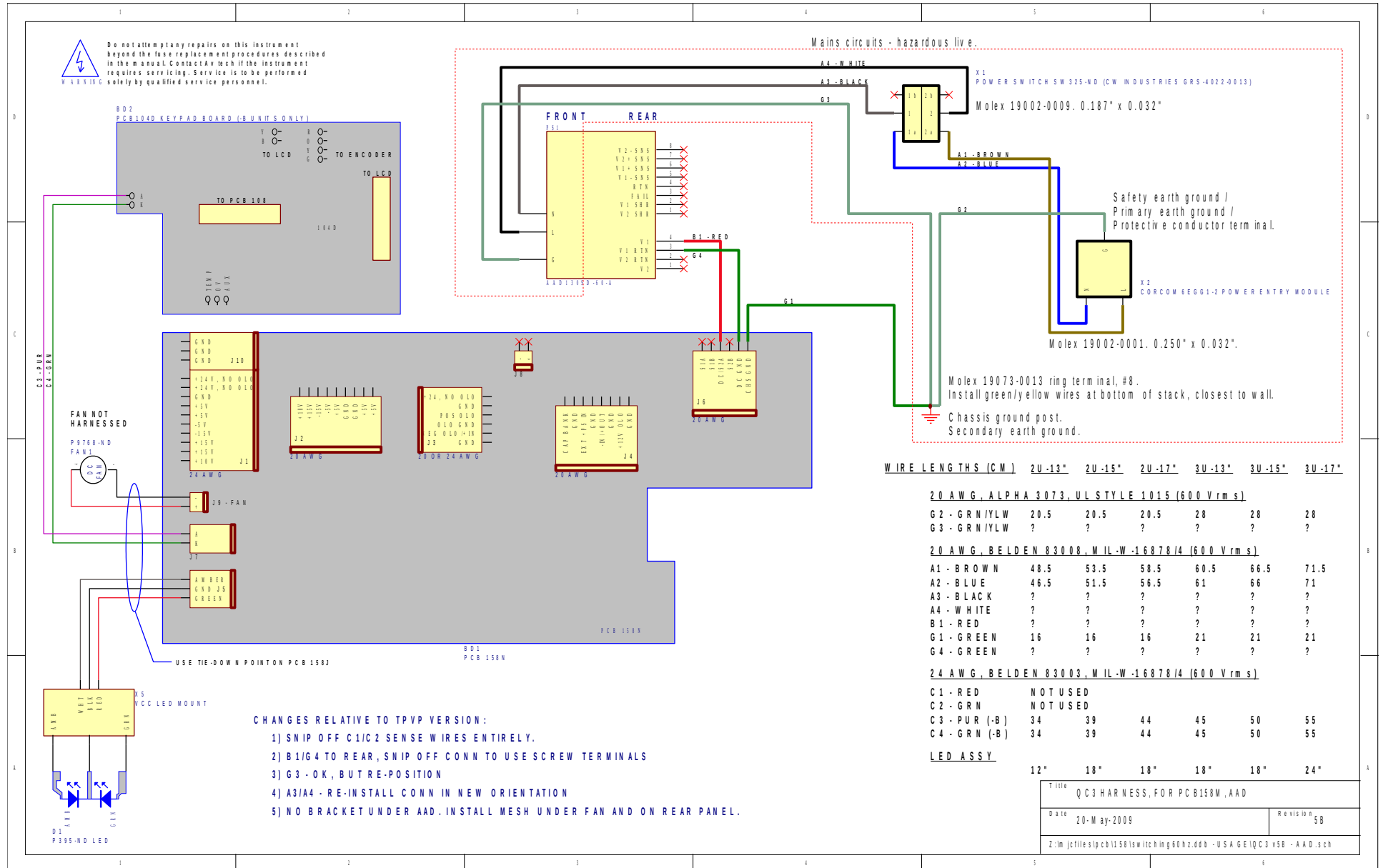

Title: QCS HARNESS, FOR PCB158M, AAD	
Date: 20-May-2009	Revision: 5B
Z:\m\j\files\ip\ch\158\sw\itc\hng\60hz.dbb - USA GE\QC3 v5B - AAD.sch	

WIRING OF HIGH VOLTAGE POWER SUPPLIES

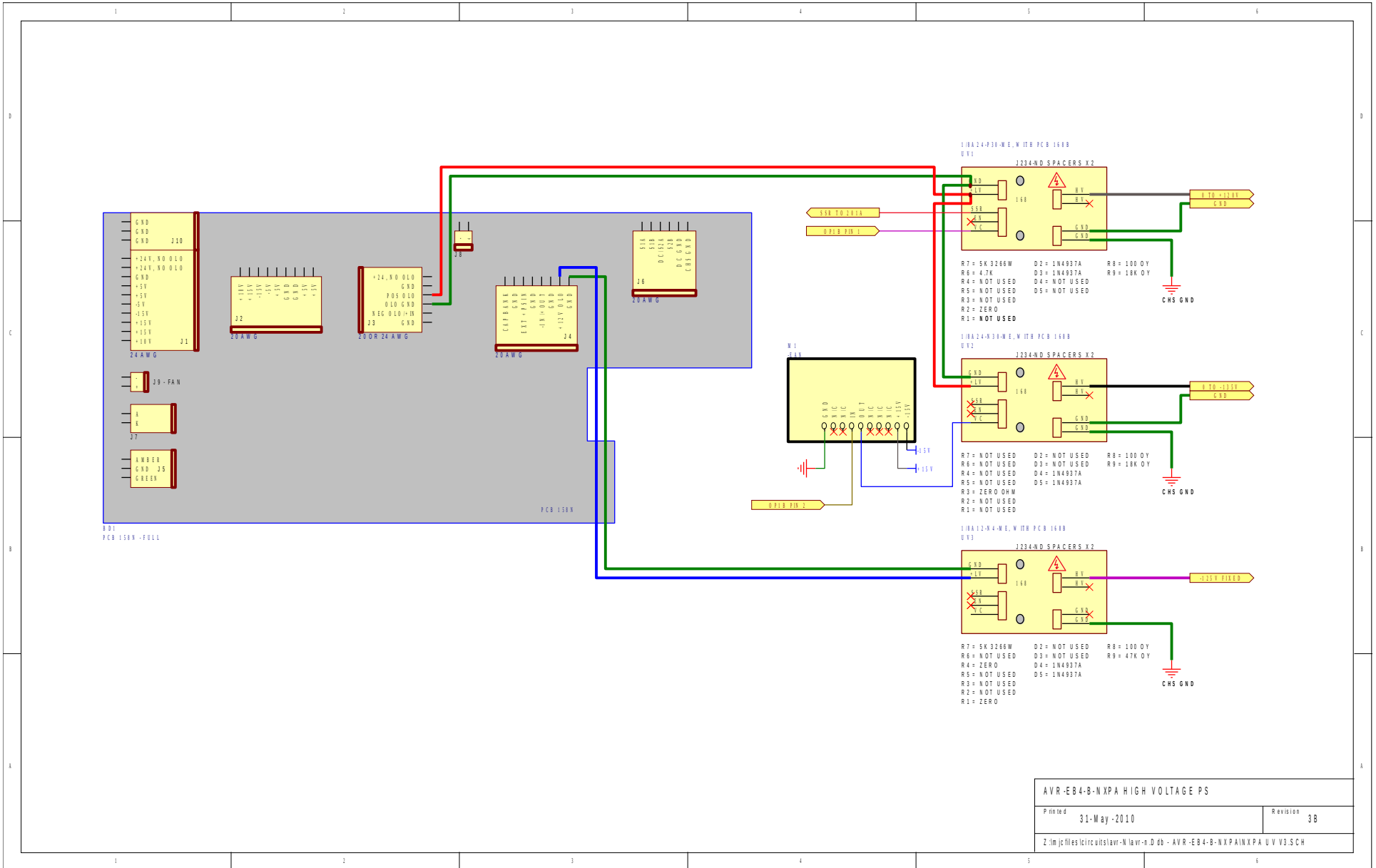

AVR-EB4-B-NXPA HIGH VOLTAGE PS		
Printed	31-May-2010	Revision 3B
Z:\m\jcs\files\circuit\slavr-n\avr-n.D\data - AVR-EB4-B-NXPA\NXPA UV V3.SCH		

PCB 158N - LOW VOLTAGE POWER SUPPLY, 1/3

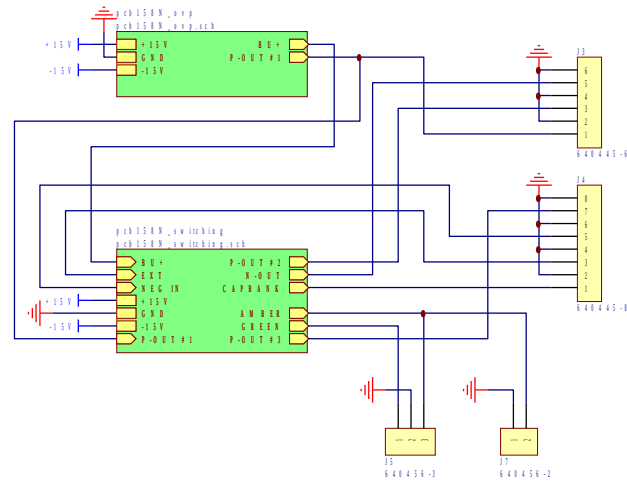

Title		LOW VOLTAGE DC/DC POWER SUPPLY
Date	12-Dec-2008	Revision
Z:\m\jcf\files\pcb158\switching\60hz.ddb - 158N\pcb158N.sch		

PCB 158N - LOW VOLTAGE POWER SUPPLY, 2/3

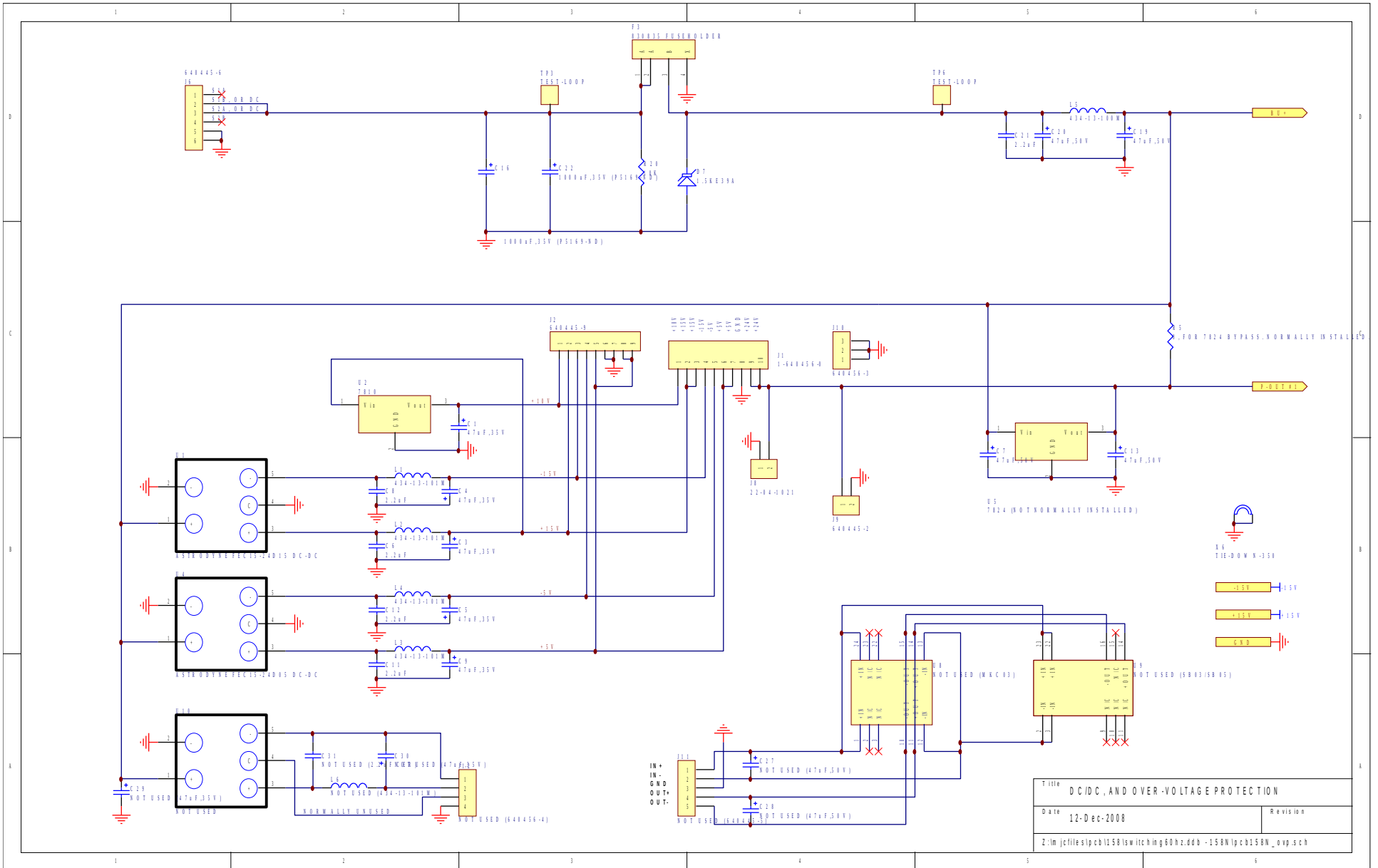

PCB 158N - LOW VOLTAGE POWER SUPPLY, 3/3

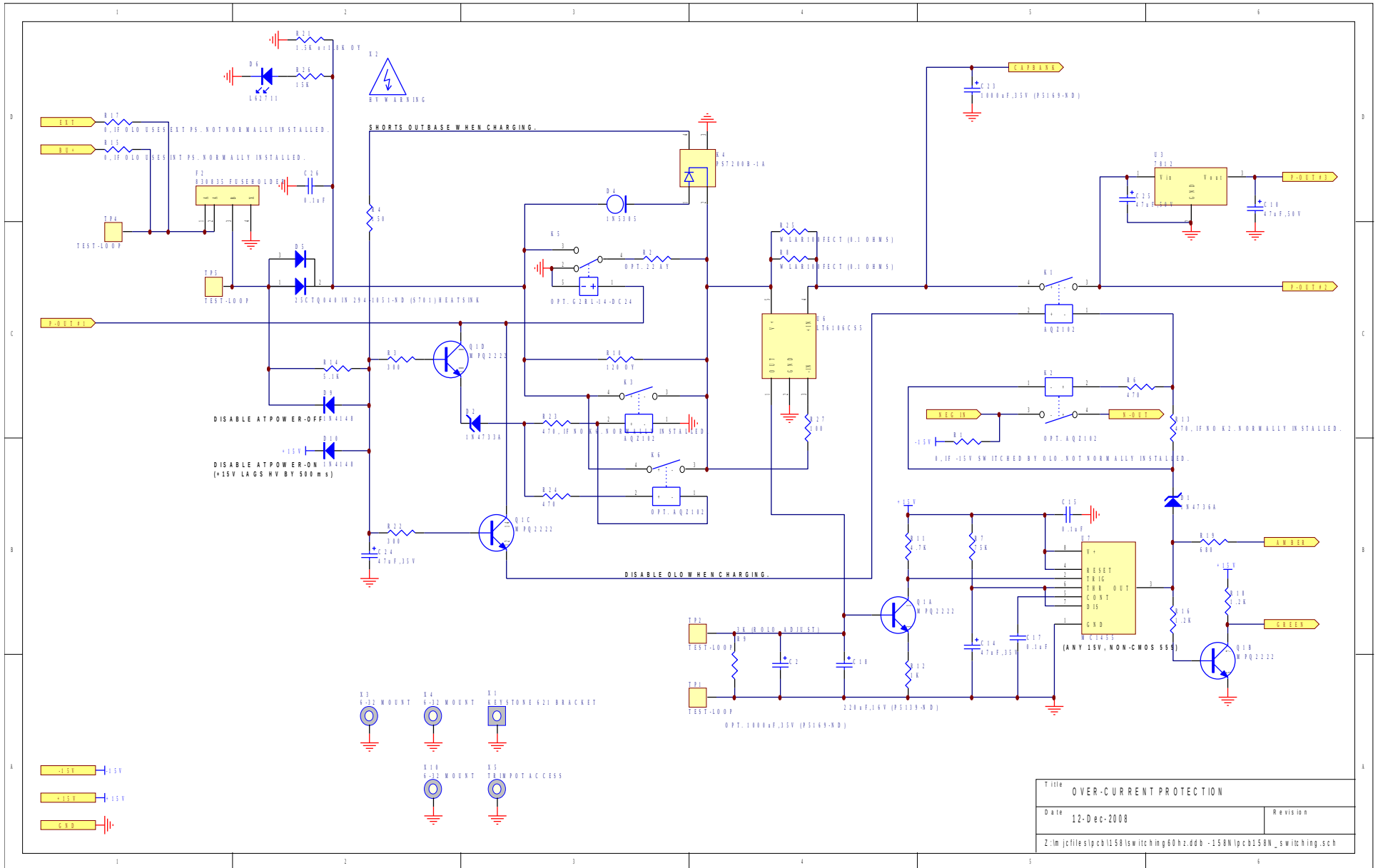

PCB 168B - HIGH VOLTAGE DC POWER SUPPLY

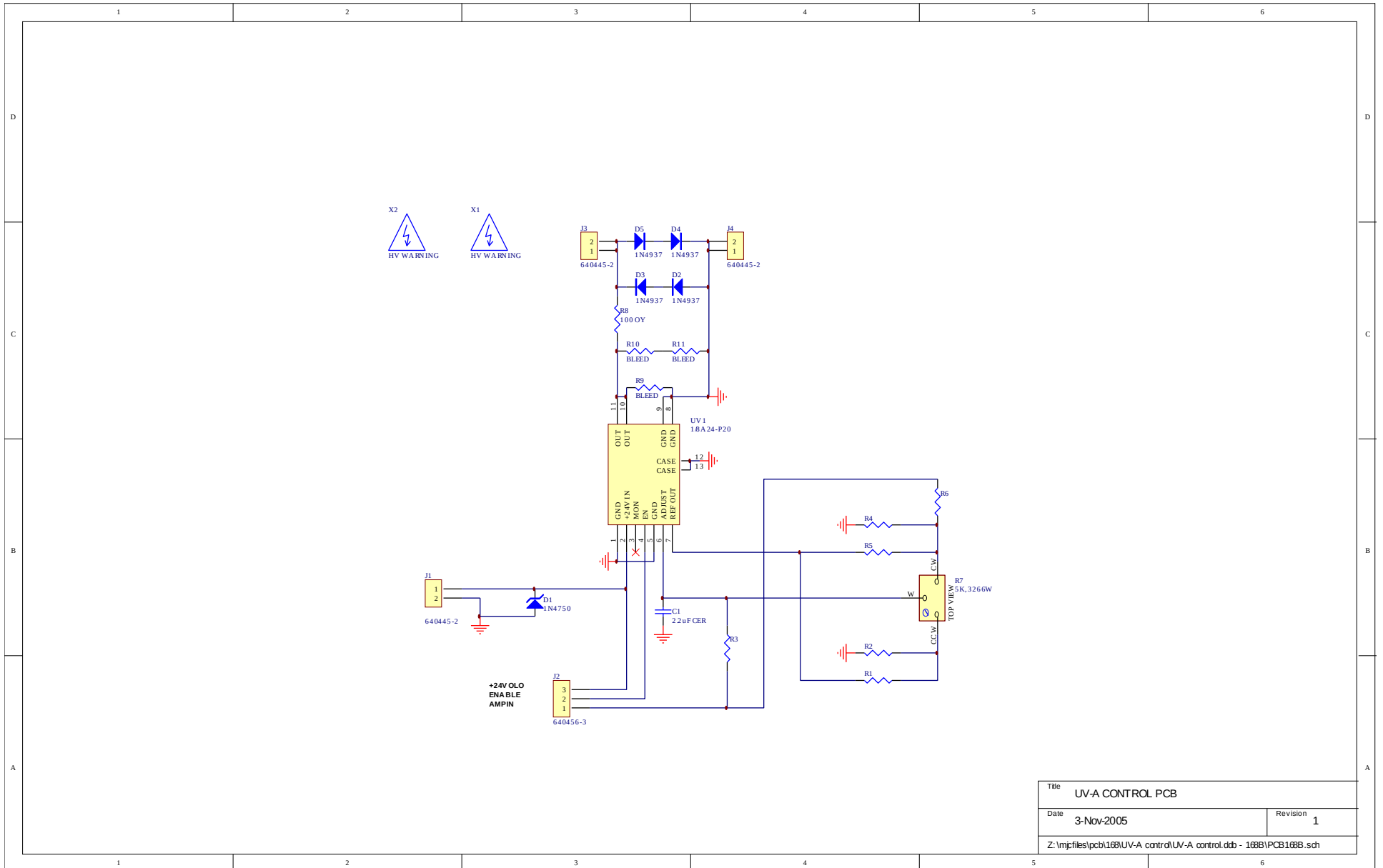

Title UV-A CONTROL PCB	
Date 3-Nov-2005	Revision 1
Z:\mpjfiles\pcb168\UV-A control\UV-A control.ddb - 168B\PCB168B.sch	

PCB 201A – SAFETY INTERLOCK

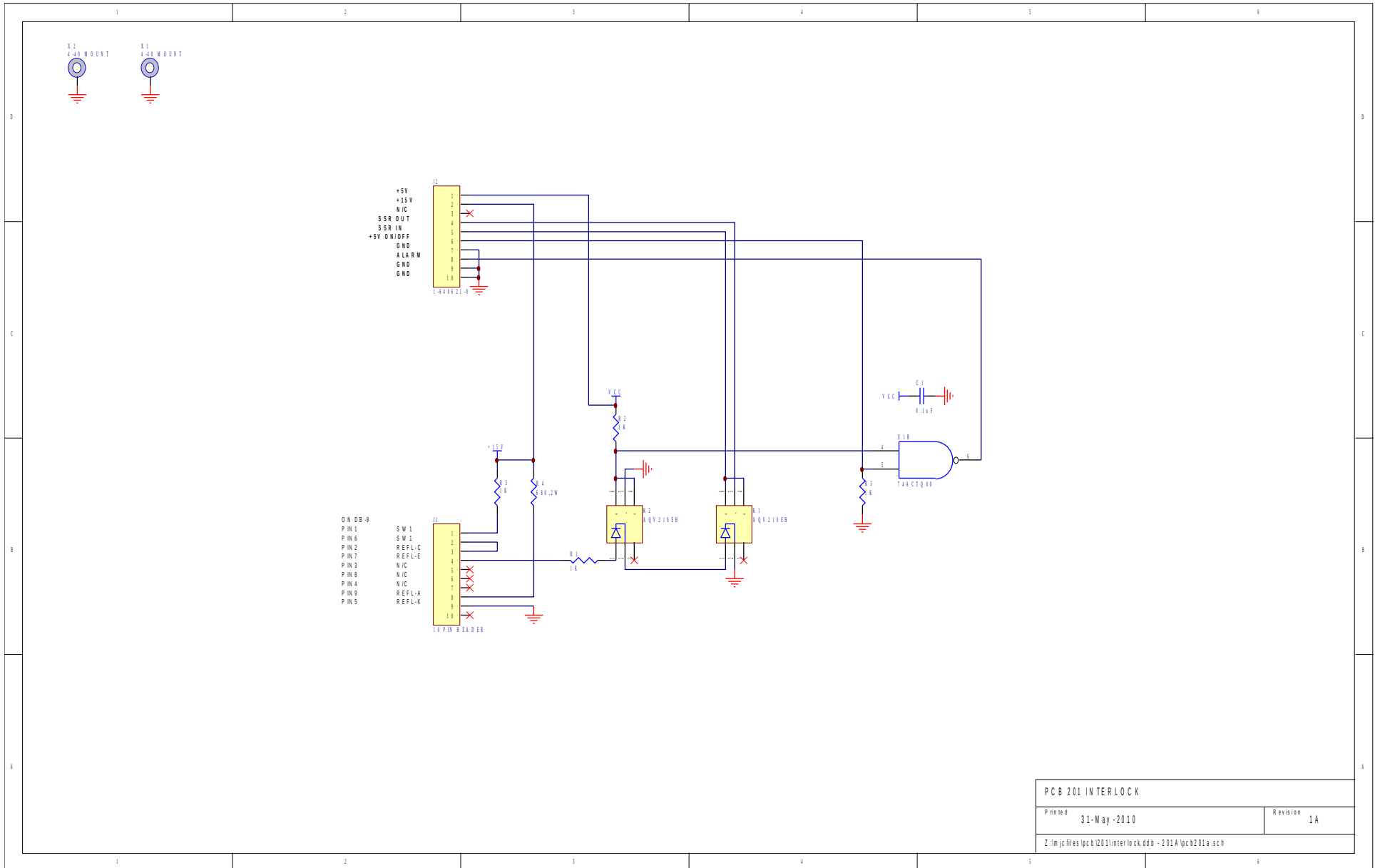

PCB 201 INTERLOCK	
Printed 31-May-2010	Revision 1A
Z:\m\j\files\pcb\201\interlock.ddb - 201A\pcb201a.sch	

PCB 104D - KEYPAD / DISPLAY BOARD, 1/3

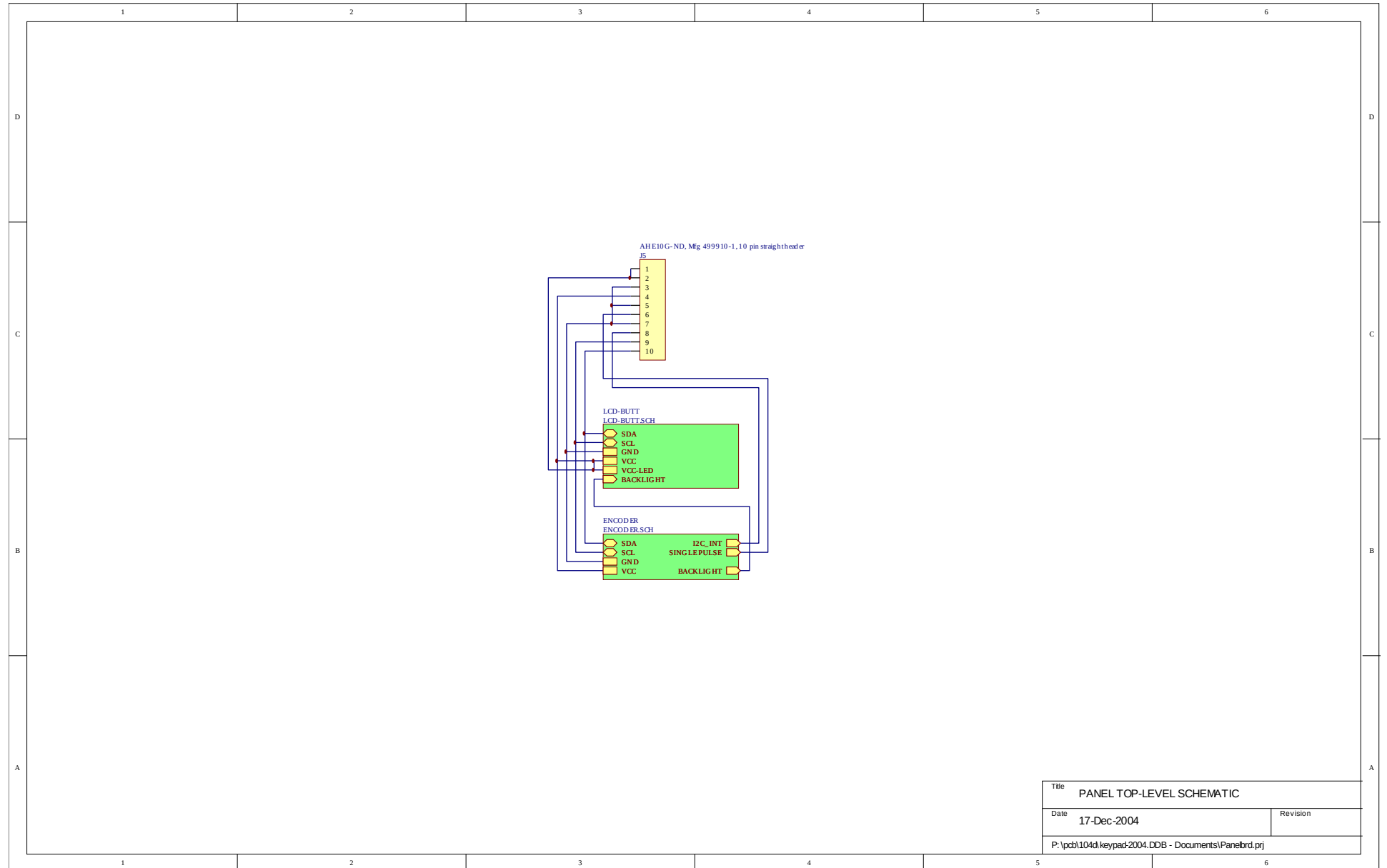

Title		PANEL TOP-LEVEL SCHEMATIC	
Date	17-Dec-2004	Revision	
P:\pcb\104d\keypad\2004.DDB - Documents\Panelbrd.prj			

PCB 104D - KEYPAD / DISPLAY BOARD, 2/3

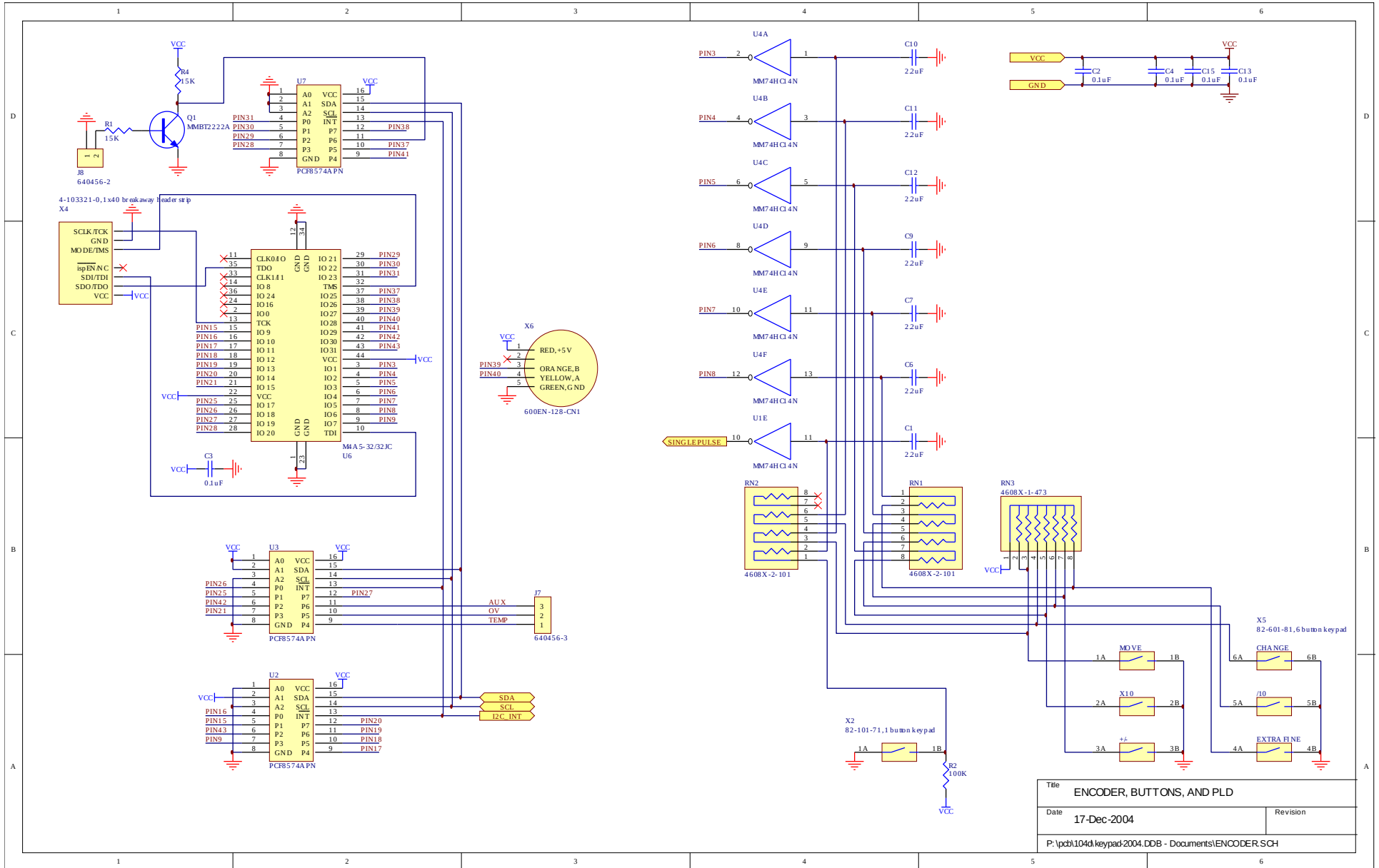

Title		ENCODER, BUTTONS, AND PLD
Date	17-Dec-2004	Revision
P:\pcb\104d\keypad\2004.DDB - Documents\ENCODER-SCH		

PCB 104D - KEYPAD / DISPLAY BOARD, 3/3

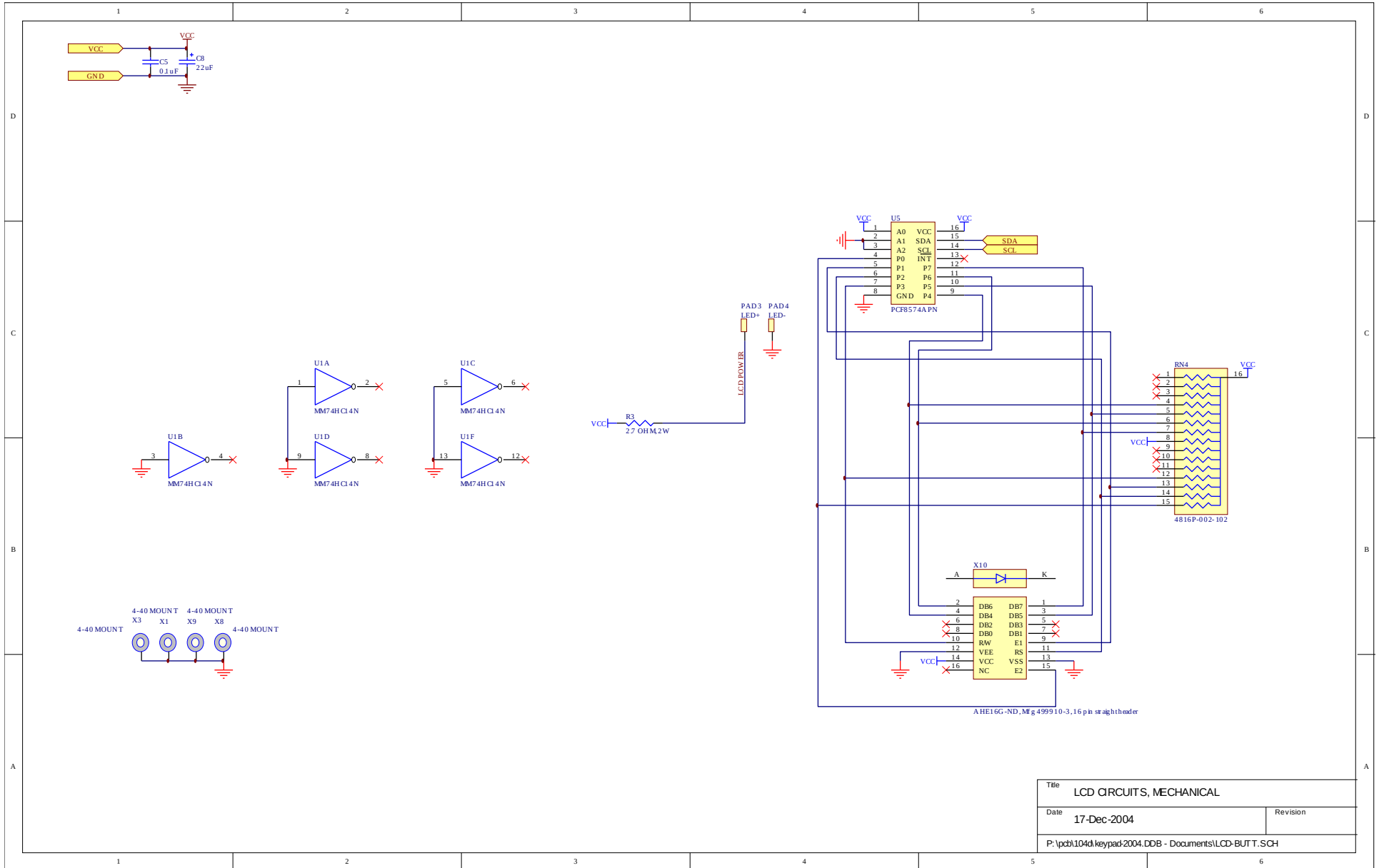

Title		LCD CIRCUITS, MECHANICAL	
Date	17-Dec-2004	Revision	
P:\pcb\104d\keypad2004.DDB - Documents\LCD-BUTT.SCH			

MAIN WIRING

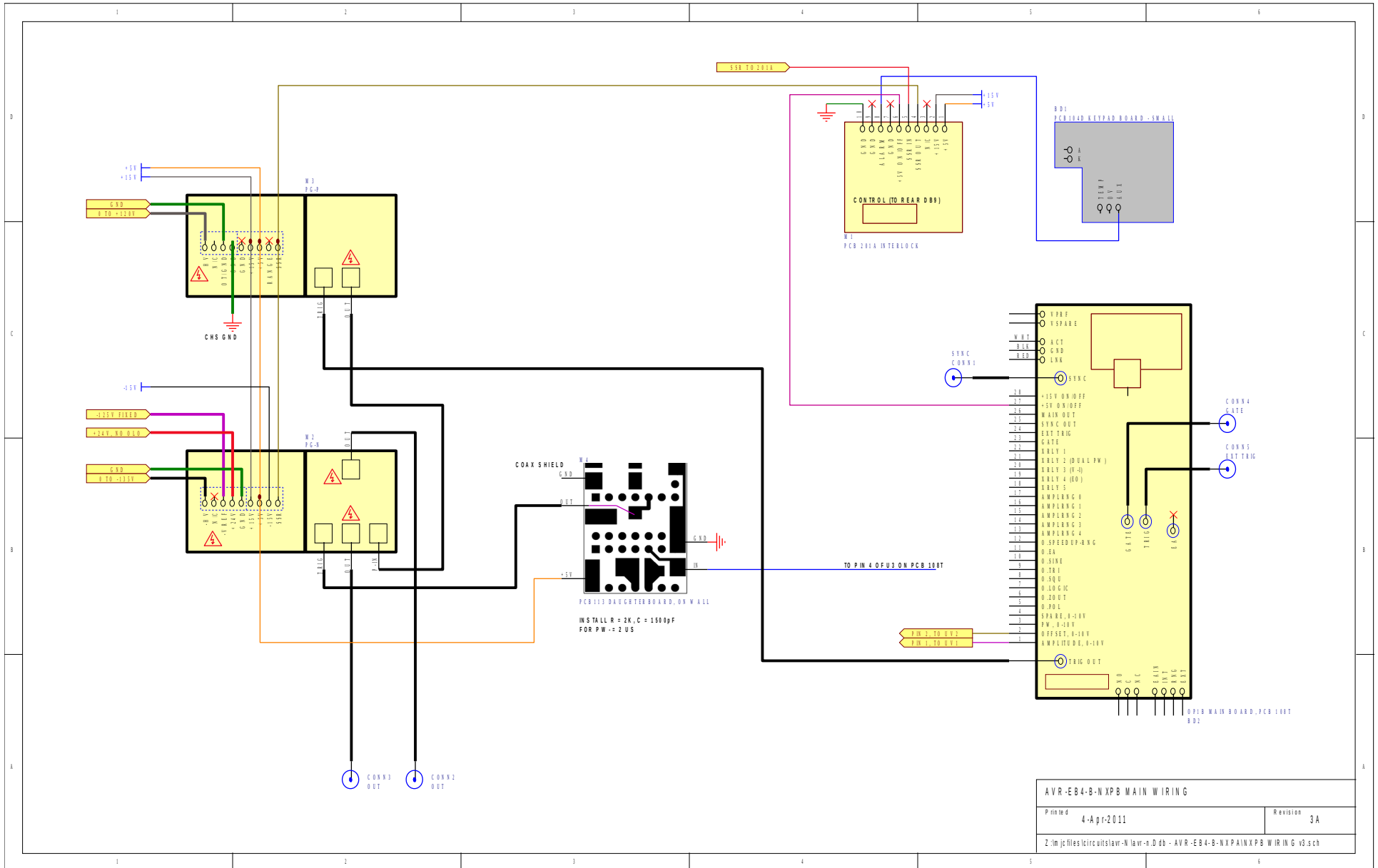

AVR-EB4-B-NXPB MAIN WIRING		
Printed	4-Apr-2011	Revision 3A
Z:\m\jct\files\circuit\slavr-N\avr-r.D\data-avr-EB4-B-NXPB\MAIN WIRING v3.sch		

STANDARD TEST JIG WIRING (AVX-TRR-MIX-NXPB)

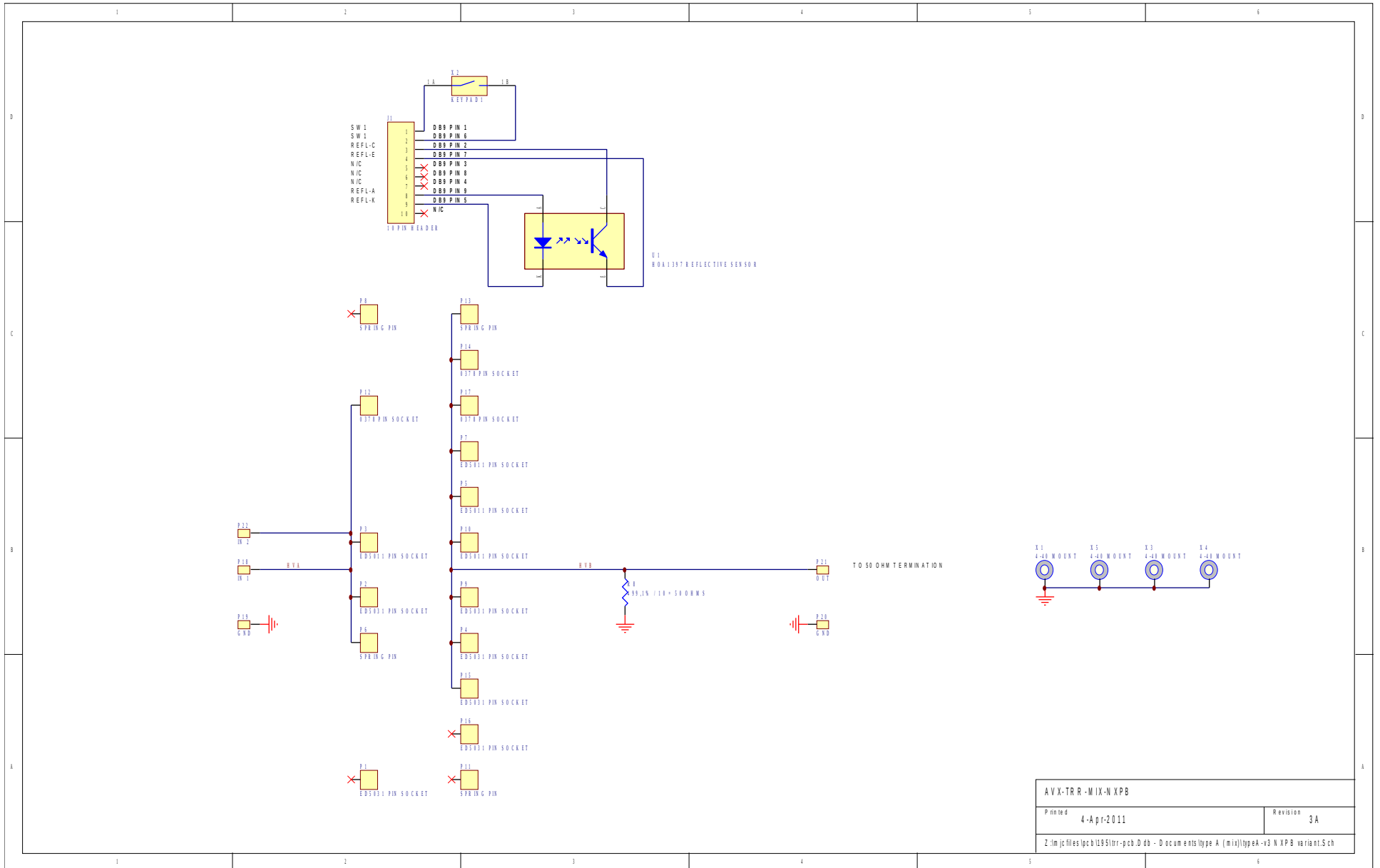

AVX-TRR-MIX-NXPB	
Printed 4-Apr-2011	Revision 3 A
Z:\m\j\files\pcb\1251trr-pcb.Ddb - Documents\type A (mix)\typeA-r3 NXPB variant.Sch	

MELF TEST JIG WIRING (AVX-TRR-MELF-NXPB)

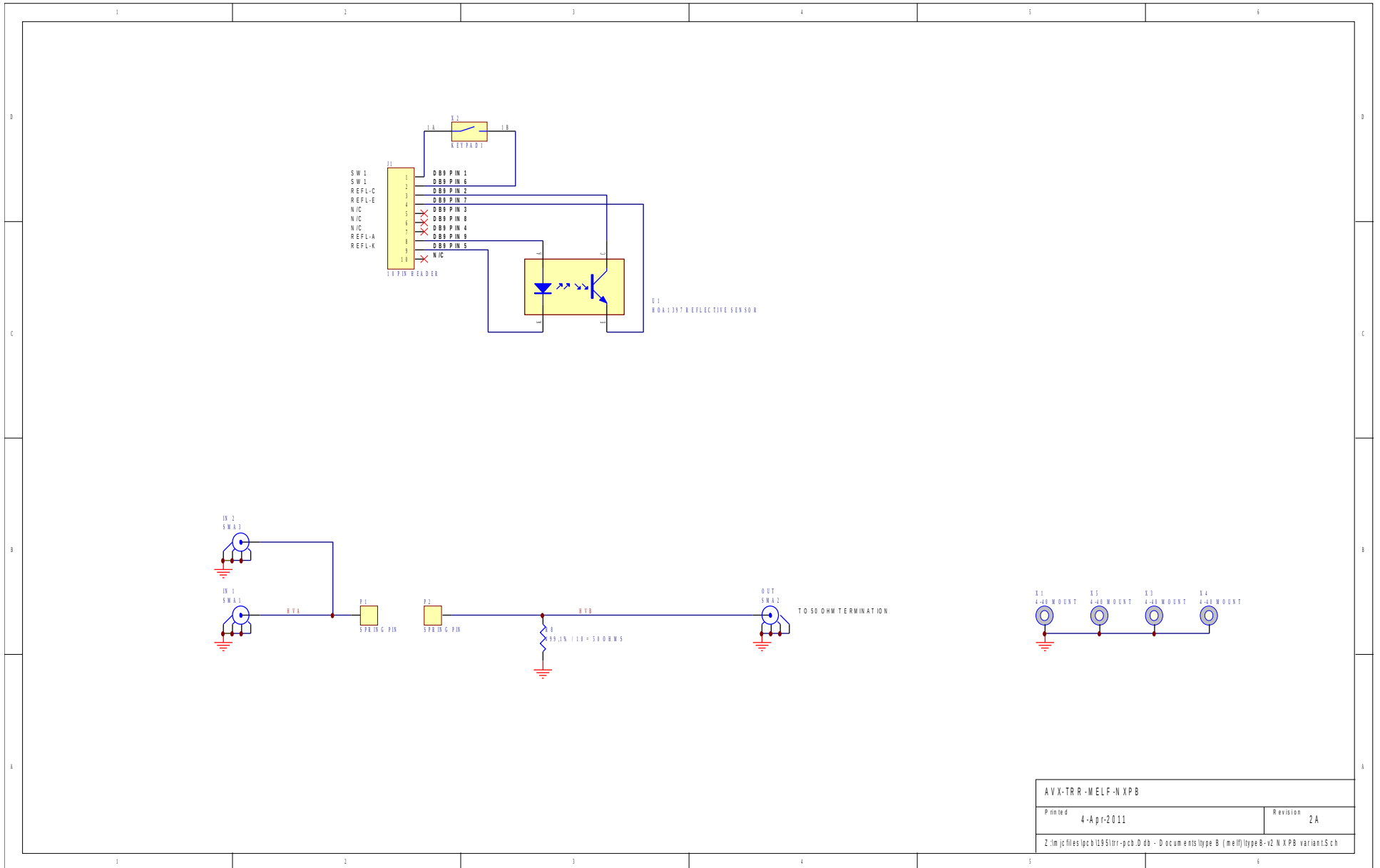

AVX-TRR-MELF-NXPB	
Printed 4-Apr-2011	Revision 2 A
Z:\m\jc\files\pcb\12951trr-pcb.dwg - Documents\type B (melf)\type B-v2 NXPB variant.Sch	

PERFORMANCE CHECK SHEET