



AVTECH ELECTROSYSTEMS LTD.

NANOSECOND WAVEFORM ELECTRONICS
SINCE 1975

P.O. BOX 265
OGDENSBURG, NY
U.S.A. 13669-0265

TEL: 888-670-8729 (USA & Canada) or +1-613-226-5772 (Intl)
FAX: 800-561-1970 (USA & Canada) or +1-613-226-2802 (Intl)

info@avtechpulse.com - <http://www.avtechpulse.com/>

BOX 5120, LCD MERIVALE
OTTAWA, ONTARIO
CANADA K2C 3H4

INSTRUCTIONS

MODELS AVR-EB5-B
AND AVR-EB4-B-MSCLA

+4A / -4A
LONG-LIFETIME PIN DIODE
REVERSE RECOVERY
MEASUREMENT SYSTEM

SERIAL NUMBER: _____

WARRANTY

Avtech Electrosystems Ltd. warrants products of its manufacture to be free from defects in material and workmanship under conditions of normal use. If, within one year after delivery to the original owner, and after prepaid return by the original owner, this Avtech product is found to be defective, Avtech shall at its option repair or replace said defective item. This warranty does not apply to units which have been disassembled, modified or subjected to conditions exceeding the applicable specifications or ratings. This warranty is the extent of the obligation assumed by Avtech with respect to this product and no other warranty or guarantee is either expressed or implied.

TECHNICAL SUPPORT

Phone: 888-670-8729 (USA & Canada) or +1-613-226-5772 (Intl)

Fax: 800-561-1970 (USA & Canada) or +1-613-226-2802 (Intl)

E-mail: info@avtechpulse.com

World Wide Web: <http://www.avtechpulse.com>

TABLE OF CONTENTS

WARRANTY.....	2
TECHNICAL SUPPORT.....	2
TABLE OF CONTENTS.....	3
INTRODUCTION.....	6
MODEL NUMBER NOTES.....	7
HIGH-VOLTAGE PRECAUTIONS.....	8
SPECIFICATIONS.....	9
EUROPEAN REGULATORY NOTES.....	10
EC DECLARATION OF CONFORMITY.....	10
DIRECTIVE 2002/95/EC (RoHS).....	10
DIRECTIVE 2002/96/EC (WEEE).....	10
INSTALLATION.....	12
VISUAL CHECK.....	12
POWER RATINGS.....	12
CONNECTION TO THE POWER SUPPLY.....	12
PROTECTION FROM ELECTRIC SHOCK.....	13
ENVIRONMENTAL CONDITIONS.....	13
FUSES.....	15
AC FUSE REPLACEMENT.....	15
DC FUSE REPLACEMENT.....	16
FUSE RATINGS.....	16
FRONT PANEL CONTROLS.....	17
REAR PANEL CONTROLS.....	19
TIMING CONTROL.....	21
BASIC TIMING CONTROL.....	21
TRIGGER MODES.....	23
GATING MODES.....	23
BASIC AMPLITUDE CONTROL.....	24
SETTING THE AMPLITUDE LEVELS.....	25
AMPLITUDE ACCURACY.....	26
DETERMINING THE LIFETIME / RECOVERY TIME.....	26
INCORRECT ORIENTATION.....	27

ACCESSIBLE VOLTAGES.....	27
POWER DISSIPATION.....	27
STANDARD TEST JIG MECHANICAL ASPECTS.....	28
AVX-TRRA TEST JIG.....	28
LEAD BENDING.....	31
TYPICAL RESULTS.....	32
UM2106B RESULTS.....	32
HUM3003 RESULTS.....	34
UM7102B RESULTS.....	35
CUSTOMIZED TEST JIGS.....	36
MELF PACKAGES.....	36
CHIP-LEVEL TESTS.....	37
DO-4 AND DO-5 STUD PACKAGES.....	38
TROUBLESHOOTING.....	40
PROGRAMMING YOUR PULSE GENERATOR.....	41
KEY PROGRAMMING COMMANDS.....	41
ALL PROGRAMMING COMMANDS.....	42
MECHANICAL INFORMATION.....	44
TOP COVER REMOVAL.....	44
RACK MOUNTING.....	44
ELECTROMAGNETIC INTERFERENCE.....	44
MAINTENANCE.....	45
REGULAR MAINTENANCE.....	45
CLEANING.....	45
WIRING DIAGRAMS.....	46
WIRING OF AC POWER.....	46
PCB 158K - LOW VOLTAGE POWER SUPPLY, 1/3.....	47
PCB 158K - LOW VOLTAGE POWER SUPPLY, 2/3.....	48
PCB 158K - LOW VOLTAGE POWER SUPPLY, 3/3.....	49
PCB 157C - HIGH VOLTAGE DC POWER SUPPLY.....	50
PCB 183A-S AND 183A-P CAPACITOR BANKS.....	51
PCB 104D - KEYPAD / DISPLAY BOARD, 1/3.....	52
PCB 104D - KEYPAD / DISPLAY BOARD, 2/3.....	53
PCB 104D - KEYPAD / DISPLAY BOARD, 3/3.....	54
MAIN WIRING.....	55

STANDARD TEST JIG WIRING (AVX-TRRA).....56
TEST JIG WIRING (AVX-TRR-MSB-MELF).....57
TEST JIG WIRING (AVX-TRR-MSB-STUD).....58
TEST JIG WIRING (AVX-TRR-ANB).....59
PERFORMANCE CHECK SHEET.....60

Manual Reference: /files/officefiles/instructword/avr-eb/avr-eb5-b/AVR-EB5-B,ed1.odt.
Last modified February 29, 2024.
Copyright © 2024 Avtech Electrosystems Ltd, All Rights Reserved.

INTRODUCTION

The AVR-EB5-B is a high performance, GPIB and RS232-equipped pulse generator for use in long-lifetime PIN diode reverse recovery time measurement systems.

More specifically, the AVR-EB5-B mainframe generates a 100 us - 1 ms wide forward-bias pulse with amplitude adjustable from +4 mA to +4A, which is immediately followed by a 100 us - 1 ms wide reverse-bias pulse with amplitude adjustable from -2V to -200V (corresponding to -40 mA to -4A, maximum). The forward and reverse amplitudes and pulse widths are independently variable. The forward-to-reverse switching time is < 50 ns (20%-80%). The forward bias pulse rise time is < 1 us.

Standard AVR-EB5-B models include one AVX-TRRA diode test jig. The instrument mainframe is connected to the test jig using one coaxial cable and one DB-9 control cable. The standard test jig contains a variety of pin sockets and posts, which may be used to hold the diode device under test (DUT). The test jig has a hinged lid, which must be fully closed to protect the user from high voltages. The output will be automatically disabled if the lid is left open. The standard AVR-TRRA test jig will accommodate TO-220AC (2 lead) packages, DO-style packages with (leads bent at 90°), and standard and reverse-polarity TO-3 packages.

The AVR-EB5-B may also be provided with different or additional standard or customized test jigs, to meet particular customer package requirements. Contact Avtech (info@avtechpulse.com) with your special requirements.

The diode-under-test is connected in series with a 50 Ohm resistance present on the test jig. In order to achieve the full +4A / -4A amplitude, the diode resistance (dV/dI at high currents) must be much less than 50 Ohms (i.e., 5 Ohms or lower).

One end of the 50 Ohm resistance is connected to ground, and access to the other end is provided through an SMA connector. This output should be terminated with 50 Ohms, and connected to a high-bandwidth (> 400 MHz) oscilloscope. The voltage across this resistance is directly proportional to the current through the diode. By observing the current waveform through the diode, the reverse recovery time may be determined.

While the provided test jig is intended to be flexible and easy to use, users can also develop their own test jigs easily.

The AVR-EB5-B includes an internal trigger source, but it can also be triggered or gated by an external source. A front-panel pushbutton can also be used to trigger the instrument.

The AVR-EB5-B features front panel keyboard and adjust knob control of the output pulse parameters along with a four line by 40-character backlit LCD display of the output amplitude, pulse repetition frequency, and delay. The instrument includes memory to store up to four complete instrument setups. The operator may use the front

panel or the computer interface to store a complete “snapshot” of all key instrument settings, and recall this setup at a later time.

This instrument is intended for use in research, development, test and calibration laboratories by qualified personnel.

MODEL NUMBER NOTES

This instrument was originally developed as a customized model, with the model number AVR-EB4-B-MSCLA.

It is now offered as a standard model, model AVR-EB5-B.

Other than the model number, these instruments are identical.

HIGH-VOLTAGE PRECAUTIONS

 **CAUTION:** This instrument provides output voltages as high as 210 Volts under normal operating conditions, and generates up to 450V internally, so extreme caution must be employed when using this instrument. The instrument should only be used by individuals who are thoroughly skilled in high voltage laboratory techniques. The following precautions should always be observed:

1. Keep exposed high-voltage wiring to an absolute minimum.
2. Wherever possible, use shielded connectors and cabling.
3. Connect and disconnect loads and cables only when the instrument is turned off.
4. Keep in mind that all cables, connectors, oscilloscope probes, and loads must have an appropriate voltage rating.

Do not attempt any repairs on the instrument, beyond the fuse replacement procedures described in this manual. Contact Avtech technical support (see page 2 for contact information) if the instrument requires servicing.

SPECIFICATIONS

Model ¹ :	AVR-EB5-B	
Application:	Reverse recovery testing of long-lifetime, high-voltage PIN diodes	
Basic waveform:	A positive pulse followed immediately by a negative pulse	
Pulse polarity:	-	+
Voltage output ² (to $R_L = 50\Omega$):	-2V to -200V	N/A
Corresponding diode current ² : (approx., depends on V_{DIODE}):	-40 mA to -4A	+10 mA to +4A
Pulse width (FWHM):	100 us to 1 ms	100 us to 1 ms
Maximum duty cycle:	0.25% ($PW_{MAX} = 250$ us at 10 Hz, or $PW_{MAX} = 1$ ms at ≤ 2.5 Hz)	
Rise time (20%-80%):	< 50 ns	< 1 us
Output impedance during pulse: (inside the mainframe)	≤ 2 Ohm	varies
PRF: internal trigger: external trigger:	1 Hz to 10 Hz 0 Hz to 10 Hz	
Delay:	auto-aligned with positive falling edge	0 to ± 1.0 s, variable
Coaxial cable to test jig: (supplied with jig)	2 meter / 6 feet, RG-316 or RG-58C/U.	
Supplied test jig:	Model AVX-TRRA. Includes pin sockets for TO-220AC (2 lead) packages, DO-style packages ³ with leads bent at 90°, and standard and reverse-polarity TO-3 packages.	
Mainframe connectors:	BNC	
GPIB and RS-232 control:	Standard on -B units. See http://www.avtechpulse.com/gpib for details.	
Trigger required:	Ext trig mode: + 5 Volts, 10 ns or wider (TTL)	
Gate input:	Active high or low, switchable. Suppresses triggering when active.	
Power requirements:	100 - 240 Volts, 50 - 60 Hz	
Dimensions: (H x W x D)	100 mm x 430 mm x 375 mm (3.9" x 17" x 14.8")	
Chassis material:	cast aluminum frame and handles, blue vinyl on aluminum cover plates	
Temperature range:	+5°C to +40°C	

EUROPEAN REGULATORY NOTES

EC DECLARATION OF CONFORMITY

We Avtech Electrosystems Ltd.
P.O. Box 5120, LCD Merivale
Ottawa, Ontario
Canada K2C 3H4

declare that this pulse generator meets the intent of Directive 89/336/EEC for Electromagnetic Compatibility. Compliance pertains to the following specifications as listed in the official Journal of the European Communities:

EN 50081-1 Emission

EN 50082-1 Immunity

and that this pulse generator meets the intent of the Low Voltage Directive 72/23/EEC as amended by 93/68/EEC. Compliance pertains to the following specifications as listed in the official Journal of the European Communities:

EN 61010-1:2001 Safety requirements for electrical equipment for measurement, control, and laboratory use



DIRECTIVE 2002/95/EC (RoHS)

This instrument is exempt from Directive 2002/95/EC of the European Parliament and of the Council of 27 January 2003 on the Restriction of the use of certain Hazardous Substances (RoHS) in electrical and electronic equipment. Specifically, Avtech instruments are considered "Monitoring and control instruments" (Category 9) as defined in Annex 1A of Directive 2002/96/EC. The Directive 2002/95/EC only applies to Directive 2002/96/EC categories 1-7 and 10, as stated in the "Article 2 - Scope" section of Directive 2002/95/EC.

DIRECTIVE 2002/96/EC (WEEE)

European customers who have purchased this equipment directly from Avtech will have completed a "WEEE Responsibility Agreement" form, accepting responsibility for WEEE

compliance (as mandated in Directive 2002/96/EC of the European Union and local laws) on behalf of the customer, as provided for under Article 9 of Directive 2002/96/EC.

Customers who have purchased Avtech equipment through local representatives should consult with the representative to determine who has responsibility for WEEE compliance. Normally, such responsibilities will lie with the representative, unless other arrangements (under Article 9) have been made.

Requirements for WEEE compliance may include registration of products with local governments, reporting of recycling activities to local governments, and financing of recycling activities.

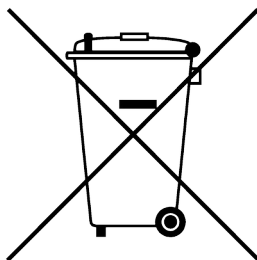

INSTALLATION

VISUAL CHECK

After unpacking the instrument, examine to ensure that it has not been damaged in shipment. Visually inspect all connectors, knobs, liquid crystal displays (LCDs), and the handles. If the instrument has been damaged, file a claim immediately with the company that transported the instrument.

The following items should be with the instrument:

- 1) A power cord.
- 2) A GPIB cable
- 3) Two instrumentation manuals (this manual and the “Programming Manual for -B Instruments”).
- 4) One test jig, with a hinged lid.
- 5) A 2 meter length of SMA-to-BNC cable.
- 6) A 2 meter DB-9 control cable.

POWER RATINGS

This instrument is intended to operate from 100 - 240 V, 50 - 60 Hz.

The maximum power consumption is 90 Watts. Please see the “FUSES” section for information about the appropriate AC and DC fuses.

This instrument is an “Installation Category II” instrument, intended for operation from a normal single-phase supply.

CONNECTION TO THE POWER SUPPLY

An IEC-320 three-pronged recessed male socket is provided on the back panel for AC power connection to the instrument. One end of the detachable power cord that is supplied with the instrument plugs into this socket. The other end of the detachable power cord plugs into the local mains supply. Use only the cable supplied with the instrument. The mains supply must be earthed, and the cord used to connect the instrument to the mains supply must provide an earth connection. (The supplied cord does this.)

 Warning: Failure to use a grounded outlet may result in injury or death due to electric shock. This product uses a power cord with a ground connection. It must be connected to a properly grounded outlet. The instrument chassis is connected to the ground wire in the power cord.

The table below describes the power cord that is normally supplied with this instrument, depending on the destination region:

Destination Region	Description	Manufacturer	Part Number
Continental Europe	European CEE 7/7 "Schuko" 230V, 50Hz	Qualtek (http://www.qualtekusa.com)	319004-T01
United Kingdom	BS 1363, 230V, 50Hz	Qualtek (http://www.qualtekusa.com)	370001-E01
Switzerland	SEV 1011, 2 30V, 50Hz	Volex (http://www.volex.com)	2102H-C3-10
Israel	SI 32, 220V, 50Hz	Volex (http://www.volex.com)	2115H-C3-10
North America, and all other areas	NEMA 5-15, 120V, 60 Hz	Qualtek (http://www.qualtekusa.com)	312007-01

PROTECTION FROM ELECTRIC SHOCK

 Operators of this instrument must be protected from electric shock at all times. The owner must ensure that operators are prevented access and/or are insulated from every connection point. In some cases, connections must be exposed to potential human contact. Operators must be trained to protect themselves from the risk of electric shock. This instrument is intended for use by qualified personnel who recognize shock hazards and are familiar with safety precautions required to avoid possibly injury. In particular, operators should:

1. Keep exposed high-voltage wiring to an absolute minimum.
2. Wherever possible, use shielded connectors and cabling.
3. Connect and disconnect loads and cables only when the instrument is turned off.
4. Keep in mind that all cables, connectors, oscilloscope probes, and loads must have an appropriate voltage rating.
5. Do not attempt any repairs on the instrument, beyond the fuse replacement procedures described in this manual. Contact Avtech technical support (see page 2 for contact information) if the instrument requires servicing. Service is to be performed solely by qualified service personnel.

ENVIRONMENTAL CONDITIONS

This instrument is intended for use under the following conditions:

1. indoor use;

2. altitude up to 2 000 m;
3. temperature 5 °C to 40 °C;
4. maximum relative humidity 80 % for temperatures up to 31 °C decreasing linearly to 50 % relative humidity at 40 °C;
5. Mains supply voltage fluctuations up to ± 10 % of the nominal voltage;
6. no pollution or only dry, non-conductive pollution.

FUSES

This instrument contains four fuses. All are accessible from the rear-panel. Two protect the AC prime power input, and two protect the internal DC power supplies. The locations of the fuses on the rear panel are shown in the figure below:

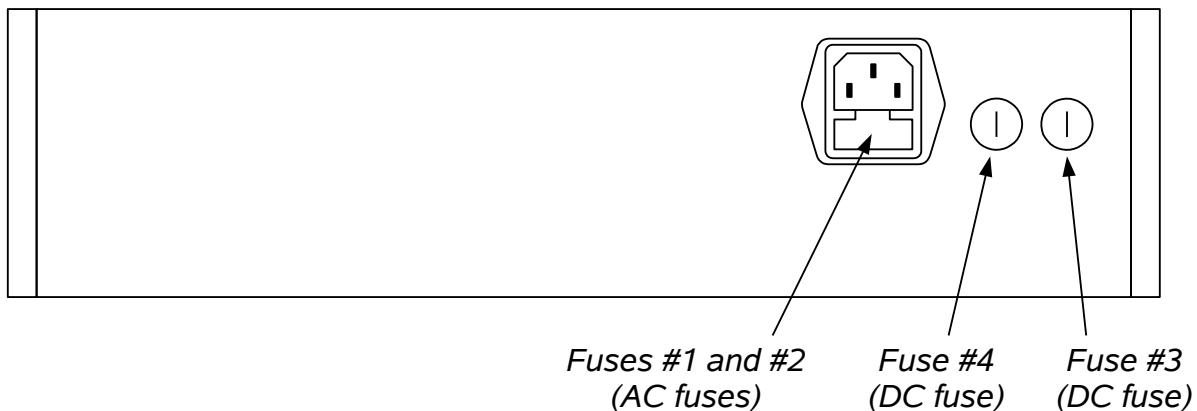

AC FUSE REPLACEMENT

To physically access the AC fuses, the power cord must be detached from the rear panel of the instrument. The fuse drawer may then be extracted using a small flat-head screwdriver, as shown below:

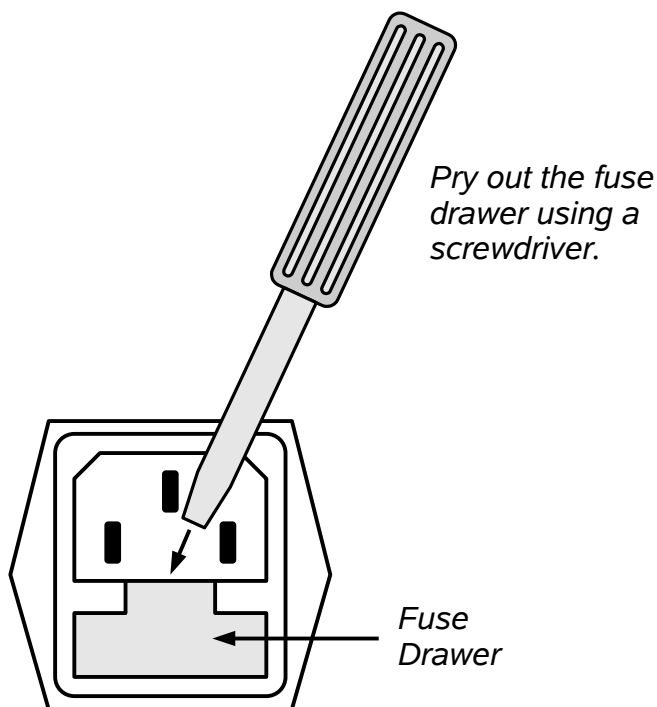

DC FUSE REPLACEMENT

The DC fuses may be replaced by inserting the tip of a flat-head screwdriver into the fuse holder slot, and rotating the slot counter-clockwise. The fuse and its carrier will then pop out.

FUSE RATINGS

The following table lists the required fuses:

Fuses	Nominal Mains Voltage	Rating	Case Size	Recommended Replacement Part	
				Littelfuse Part Number	Digi-Key Stock Number
#1, #2 (AC)	115 V	0.8A, 250V, Time-Delay	5×20 mm	0218.800HXP	F2418-ND
	230 V	0.5A, 250V, Time-Delay	5×20 mm	0218.500HXP	F2416-ND
#3 (DC)	N/A	2.0A, 250V, Time-Delay	5×20 mm	0218002.HXP	F2420-ND
#4 (DC)	N/A	1.6A, 250V, Time-Delay	5×20 mm	021801.6HXP	F2424-ND

The fuse manufacturer is Wickmann (<http://www.wickmann.com/>).

Replacement fuses may be easily obtained from Digi-Key (<http://www.digikey.com/>) and other distributors.

FRONT PANEL CONTROLS

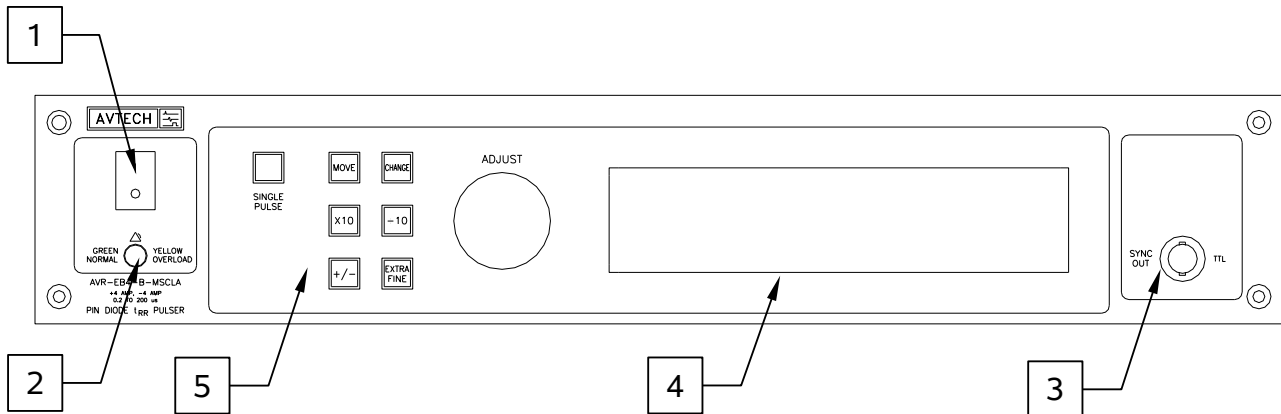

1. POWER Switch. This is the main power switch. When turning the instrument on, there may be a delay of several seconds before the instrument appears to respond.
2. OVERLOAD Indicator. When the instrument is powered, this indicator is normally green, indicating normal operation. If this indicator is yellow, an internal automatic overload protection circuit has been tripped. If the unit is overloaded (by operating at an exceedingly high duty cycle or by operating into a very low impedance), the protective circuit will disable the output of the instrument and turn the indicator light yellow. The light will stay yellow (i.e. output disabled) for about 5 seconds after which the instrument will attempt to re-enable the output (i.e. light green) for about 1 second. If the overload condition persists, the output will be disabled again (i.e. light yellow) for another 5 seconds. If the overload condition has been removed, the instrument will resume normal operation.

This overload indicator may flash yellow briefly at start-up. This is not a cause for concern.

3. SYNC OUT. This connector supplies a SYNC output that can be used to trigger other equipment, particularly oscilloscopes. This signal leads (or lags) the main output by a duration set by the "DELAY" controls and has an approximate amplitude of +3 Volts to $R_L > 50\Omega$ with a pulse width of approximately 100 ns.
4. LIQUID CRYSTAL DISPLAY (LCD). This LCD is used in conjunction with the keypad to change the instrument settings. Normally, the main menu is displayed, which lists the key adjustable parameters and their current values. The "Programming Manual for -B Instruments" describes the menus and submenus in detail.

5. KEYPAD.

Control Name	Function
MOVE	This moves the arrow pointer on the display.
CHANGE	This is used to enter the submenu, or to select the operating mode, pointed to by the arrow pointer.
×10	If one of the adjustable numeric parameters is displayed, this increases the setting by a factor of ten.
÷10	If one of the adjustable numeric parameters is displayed, this decreases the setting by a factor of ten.
+/-	If one of the adjustable numeric parameters is displayed, and this parameter can be both positive or negative, this changes the sign of the parameter.
EXTRA FINE	This changes the step size of the ADJUST knob. In the extra-fine mode, the step size is twenty times finer than in the normal mode. This button switches between the two step sizes.
ADJUST	This large knob adjusts the value of any displayed numeric adjustable values, such as frequency, pulse width, etc. The adjust step size is set by the "EXTRA FINE" button. When the main menu is displayed, this knob can be used to move the arrow pointer.

REAR PANEL CONTROLS

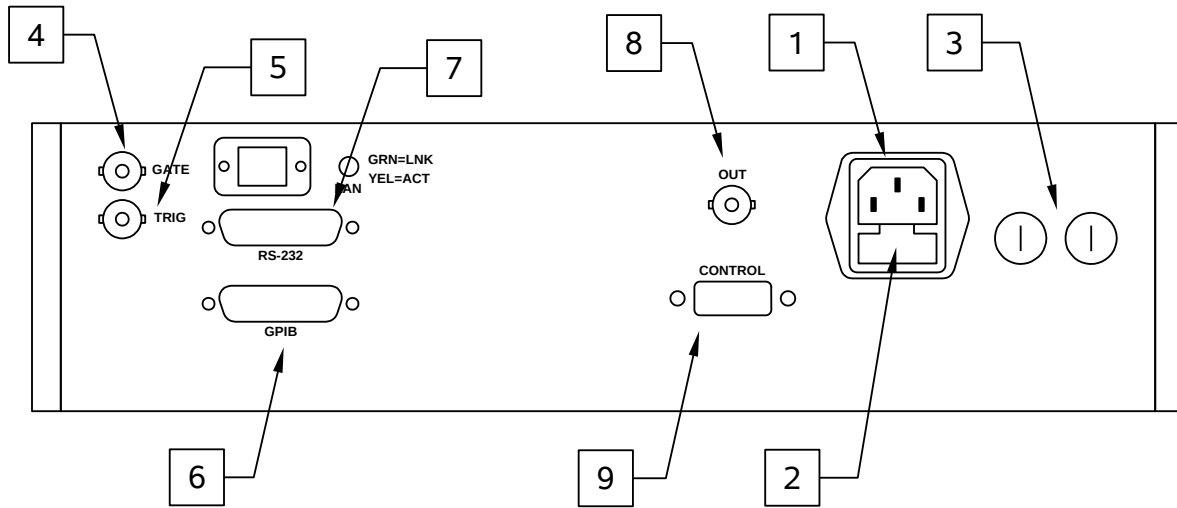

1. AC POWER INPUT. An IEC-320 C14 three-pronged recessed male socket is provided on the back panel for AC power connection to the instrument. One end of the detachable power cord that is supplied with the instrument plugs into this socket.
2. AC FUSE DRAWER. The two fuses that protect the AC input are located in this drawer. Please see the “FUSES” section of this manual for more information.
3. DC FUSES. These two fuses protect the internal DC power supplies. Please see the “FUSES” sections of this manual for more information.
4. GATE. This TTL-level (0 and +5V) logic input can be used to gate the triggering of the instrument. This input can be either active high or active low, depending on the front panel settings or programming commands. (The instrument triggers normally when this input is unconnected). When set to active high mode, this input is pulled-down to ground by a 1 k Ω resistor. When set to active low mode, this input is pulled-up to +5V by a 1 k Ω resistor.
5. TRIG. This TTL-level (0 and +5V) logic input can be used to trigger the instrument, if the instrument is set to triggering externally. The instrument triggers on the rising edge of this input. The input impedance of this input is 1 k Ω . (Depending on the length of cable attached to this input, and the source driving it, it may be desirable to add a coaxial 50 Ohm terminator to this input to provide a proper transmission line termination. The Pasternack (www.pasternack.com) PE6008-50 BNC feed-thru 50 Ohm terminator is suggested for this purpose.)
6. GPIB Connector. A standard GPIB cable can be attached to this connector to allow the instrument to be computer-controlled. See the “Programming Manual for -B Instruments” for more details on GPIB control.

7. RS-232 Connector. A standard serial cable with a 25-pin male connector can be attached to this connector to allow the instrument to be computer-controlled. See the “Programming Manual for -B Instruments” for more details on RS-232 control.
8. OUT CONNECTOR. This BNC connector provides the pulse output signal to the test jig. This output should be connected to the corresponding input on the test jig using the supplied BNC-to-SMA coaxial cable.

 Caution: Voltages as high as 450V may be present on the center conductor of this output connector. Avoid touching this conductor. Connect to this connector using standard coaxial cable, to ensure that the center conductor is not exposed.

9. CONTROL Connector. This DB-9 female connector should be connected to the corresponding connector on the test jig using the supplied DB-9 cable. This cable contains the safety interlock signals that ensure that the test jig lid is closed. The pinout is as follows:

Pin 1 - To test jig switch 1.

Pin 2 - To test jig switch 2.

Pin 5 - Ground.

Pin 6 - To test jig switch 1.

Pin 7 - To test jig switch 2.

Pin 9 - Safety sensor power supply (+15V through 680 Ohms).

When the test jig lid is safely closed, Pin 1 is shorted to Pin 6, and Pin 2 is shorted to Pin 7.

TIMING CONTROL

BASIC TIMING CONTROL

The instrument mainframe can be triggered by its own internal clock or by an external TTL trigger signal. In either case, two output channels respond to the trigger: OUT and SYNC.

The OUT output is a bipolar signal that drives the test jig described later. The positive and negative amplitudes are adjustable. The pulse widths are variable over a 100 μ s – 1 ms range.

The SYNC pulse is a fixed-width TTL-level reference pulse used to trigger oscilloscopes or other measurement systems. When the delay is set to a positive value the SYNC pulse precedes the OUT output. When the delay is set to a negative value the SYNC pulse follows the OUT output.

These pulses are illustrated below, assuming internal triggering and a positive delay:

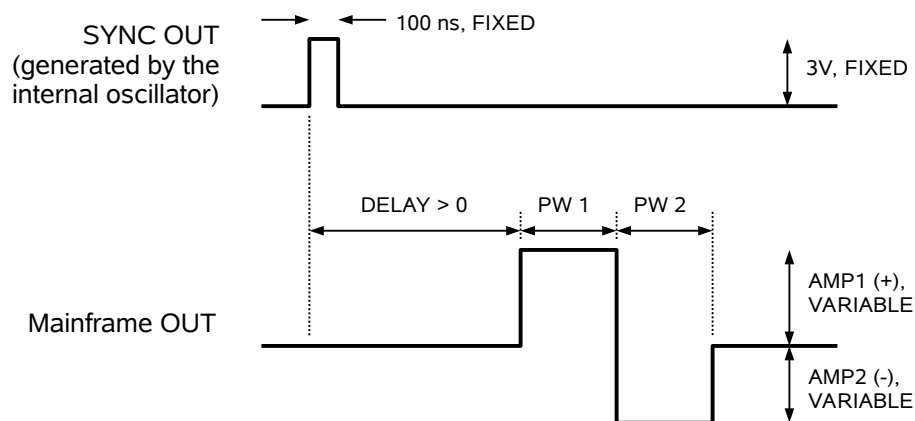

Figure A

If the delay is negative, the order of the SYNC and OUT outputs is reversed:

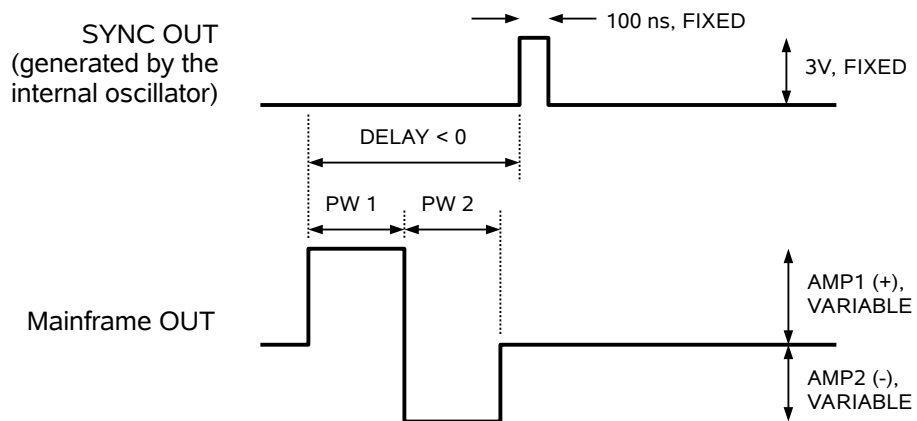

Figure B

The next figure illustrates the relationship between the signal when an external TTL-level trigger is used:

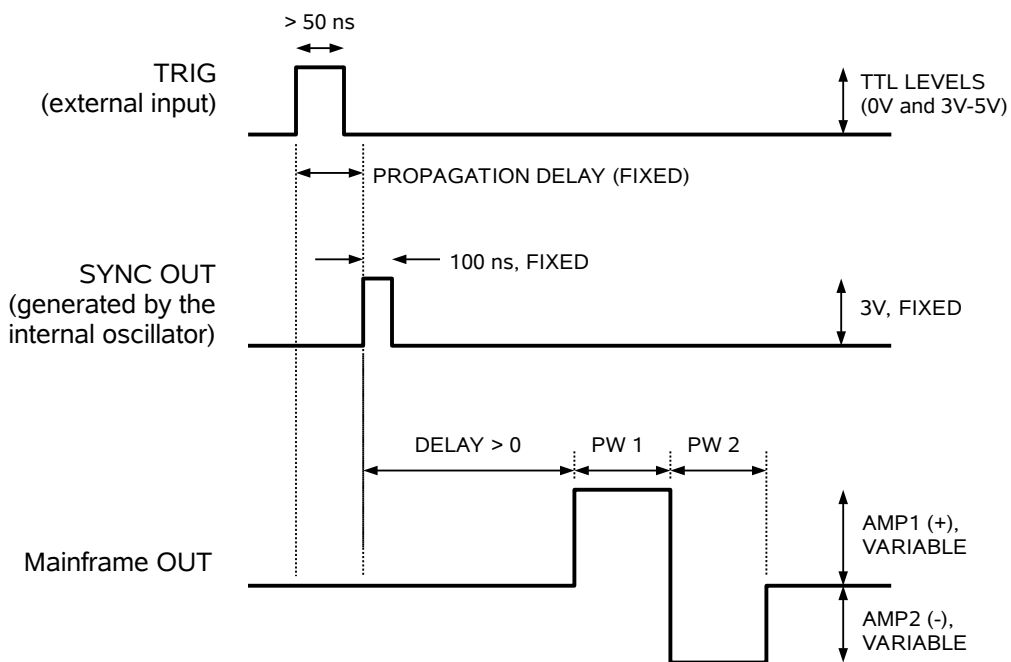

Figure C

As before, if the delay is negative, the order of the SYNC and OUT outputs is reversed.

The delay and frequency (when in the internal mode) of the OUT output can be varied with front panel controls or via the GPIB or RS-232 computer interfaces.

TRIGGER MODES

This instrument has four trigger modes:

- Internal Trigger: the instrument controls the trigger frequency, and generates the clock internally.
- External Trigger: the instrument is triggered by an external TTL-level clock on the back-panel TRIG connector.
- Manual Trigger: the instrument is triggered by the front-panel “SINGLE PULSE” pushbutton.
- Hold Trigger: the instrument is set to not trigger at all.

These modes can be selected using the front panel trigger menu, or by using the appropriate programming commands. (See the “Programming Manual for -B Instruments” for more details.)

GATING MODES

Triggering can be suppressed by a TTL-level signal on the rear-panel GATE connector. The instrument can be set to stop triggering when this input high or low, using the front-panel gate menu or the appropriate programming commands. When gated, the output will complete the full pulse width if the output is high, and then stop triggering. Pulses are not truncated.

BASIC AMPLITUDE CONTROL

The basic test arrangement for the AVR-EB5-B is shown in the figure below. The OUT output on the instrument mainframe is connected to the IN input on test jig (model AVX-TRRA, or a customized variant) using the supplied BNC-to-SMA coaxial cable, and the CONTROL connectors are connected together using the supplied DB-9 cable.

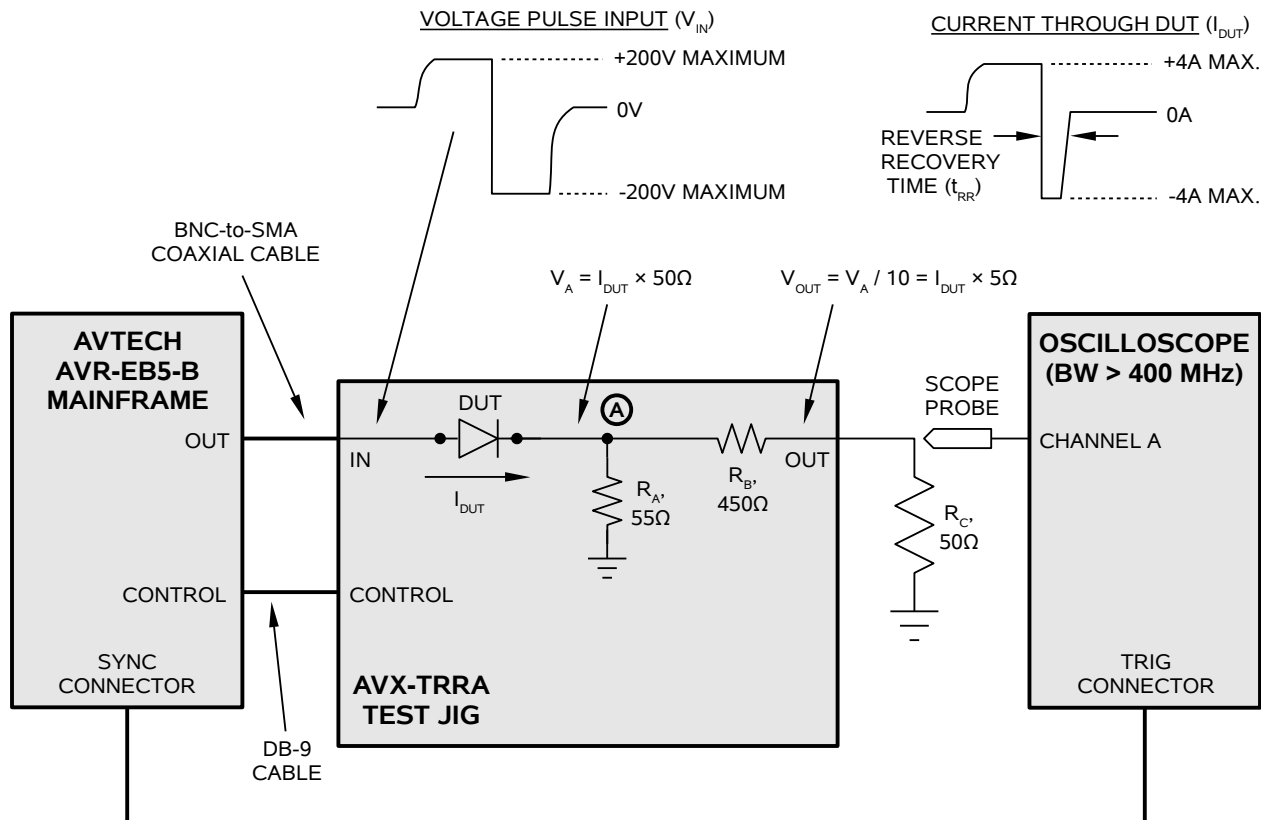

⚠ A 50 Ohm resistance (R_C in the diagram above) must be connected to ground on the output.

⚠ If resistor R_C is omitted accidentally, the voltage on the OUT connector of the test jig can be as high as 210V! For this reason, the OUT output should never be connected directly to an oscilloscope input – you may damage it! Use an attenuator or a discrete resistor with an oscilloscope probe to protect your oscilloscope.

⚠ The voltage output can be very low in the forward direction. For instance, a +10 mA bias will generate a 50 mV output. You may need to use averaging on the oscilloscope to eliminate noise. Using attenuators will make the problem worse.

The total effective resistance of resistors R_A , R_B , and R_C in the diagram above is 50 Ohms. Thus, the voltage at point "A" is simply given by:

$$V_A = I_{DUT} \times 50\Omega$$

where I_{DUT} is the current through the device under test. A 450 Ohm resistance (R_B) is present in series with the measurement output. When a 50 Ohm resistance (R_C) is installed on the output (by the user), the output voltage will be one-tenth of V_A due to the resistor-divider effect. That is:

$$V_{OUT} = V_A / 10 = I_{DUT} \times 5\Omega$$

This is the key equation for relating the observed voltage waveform to the DUT current.

SETTING THE AMPLITUDE LEVELS

The amplitude of the positive and negative portions of the PULSE waveform may be set from the front panel of the instrument, or by computer command.

The positive output may be programmed in terms of current, in the range of +4 mA to +4A. (Internally, the instrument generates a voltage pulse of 0-400V with an output impedance that auto-ranges to 50, 500, or 5000 Ohms. The instrument calculates the appropriate output impedance and voltage required to generate the programmed current, assuming that the diode forward voltage drop is ~ 0.7V).

The negative output may be programmed in terms of voltage, in the range of 0 to -200V. The negative voltage ("AMP2" on the front panel display) is related to the reverse diode current by:

$$I_{REVERSE} \approx AMP2 / (50\Omega + R_{DIODE-REVERSE}).$$

where $R_{DIODE-REVERSE}$ is the effective resistance of the diode under reverse bias. (Some diodes may have large values of $R_{DIODE-REVERSE}$, which may prevent the maximum reverse currents of -4A from being reached.)

Typical test situations will use small forward currents and large reverse currents. For instance, setting AMP1 to +10 mA and AMP2 to -100V will provide $I_F = 10$ mA and $I_R \approx -2$ Amps.

When increasing the amplitude, beware that the instrument may take several seconds to stabilize the internal capacitor banks. (Active discharge circuits ensure that the amplitude decreases rapidly when lowering the amplitude.)

AMPLITUDE ACCURACY

⚠ Due to the variations in V_F and $R_{\text{DIODE-REVERSE}}$ as a function of operating conditions, the AMP1 and AMP2 settings *should not be relied upon for any degree of accuracy*. Instead the voltage at the OUT terminal on the test jig should be monitored with a calibrated oscilloscope. As mentioned above, $I_{\text{DUT}} = V / 5\Omega$.

R_A and R_B can be measured directly on the test jig (with the test jig disconnected) to determine calibrated relationships, if desired. R_C is provided by the user, and can be calibrated as required.

DETERMINING THE LIFETIME / RECOVERY TIME

When a PIN diode is in a forward-conducting steady state, the charge stored in the diode junction is given by:

$$Q = I_F \times \tau$$

where I_F is the forward current and τ is the carrier lifetime.

When switching to the reverse bias state, this charge will be removed from the diode by conduction and by recombination of minority carriers. If the reverse current I_R is much larger than the forward current I_F ($I_R \gg I_F$), then the charge will be removed almost entirely by conduction, and the duration of the reverse transient (t_R) will be much less than τ .

Thus, to measure τ , the diode should be pulsed with a small forward current I_F for a duration (PW) long enough to reach steady-state (PW $\gg \tau$), and should then be pulsed by a large reverse current ($I_R \gg I_F$). The area of the reverse transient (the integral of the curve, A) is then approximately equal to the stored charge:

$$A \approx Q$$

so

$$\tau \approx A / I_F$$

To measure “A”, the waveform should be measured with an oscilloscope equipped with an area-measuring function, or by using a data-acquisition card with appropriate software routines. The AVR-EB5-B itself does not perform this function.

If you use an oscilloscope with an area-measuring function, be aware that the measurement may depend on the time-scale used to display the waveform, especially if the reverse transient has a long “tail”. It may require some experimentation to obtain the appropriate oscilloscope settings.

See the “Typical Results” section for further discussion.

INCORRECT ORIENTATION

The instrument and the DUT will not be damaged if the diode is installed with the incorrect orientation (i.e., with the anode and cathode reversed). However, incorrect waveforms will be generated.

ACCESSIBLE VOLTAGES

The mainframe provides pulsed voltages of up to 210V to the test jig. For this reason, the output is automatically disabled when the test jig lid is open. The lid must be closed to obtain measurements.

 Shielded cabling should be used for all connections to the "IN" and "OUT" terminals on the test jig, and the "OUT" connector on the mainframe.

 When used properly (with $R_C = 50$ Ohms), the maximum voltage on the test jig OUT terminal will be 24V, approximately. However, if R_C is not connected, the maximum voltage at the OUT terminal may be as high as 210V. Avoid feeding this output directly into an oscilloscope. Always use a probe or an attenuator!

 When used properly, the maximum voltage on the mainframe OUT terminal will be 210V, approximately. However, if R_C is not connected, the maximum voltage at the OUT terminal may be as high as 400V.

POWER DISSIPATION

The worst-case power dissipation (at 0.25% duty cycle, +4A, -200V, into a short-circuit DUT) in the test jig is 4 Watts.

Operation for prolonged periods under these worst-case conditions will cause the test jig resistors to heat up, and will ultimately reduce the test jig lifespan.

To avoid unnecessary power dissipation:

1. Set the pulse width and pulse repetition frequencies to low values, rather than high values, where practical.
2. Take care to ensure that the device under test (DUT) is not likely to fail as a short circuit.

Under most typical operating conditions appropriate for PIN diode testing (for example, AMP1 = -10 mA, AMP2 = -200V, with the DUT operating properly and terminating the reverse conduction within several tens of microseconds), power dissipation in the test jig will be minimal.

STANDARD TEST JIG MECHANICAL ASPECTS

One AVX-TRRA test jig is normally supplied with the mainframe, unless the customer has requested a different or additional test jigs.

AVX-TRRA TEST JIG

The AVX-TRRA test jig accepts a range of through-hole and axial devices, using pin sockets and spring-loaded pins. It is intended for use with diodes in DO-41, TO-220, DO-204AR, TO-3 or similar packages. A photo of the arrangement is shown below:

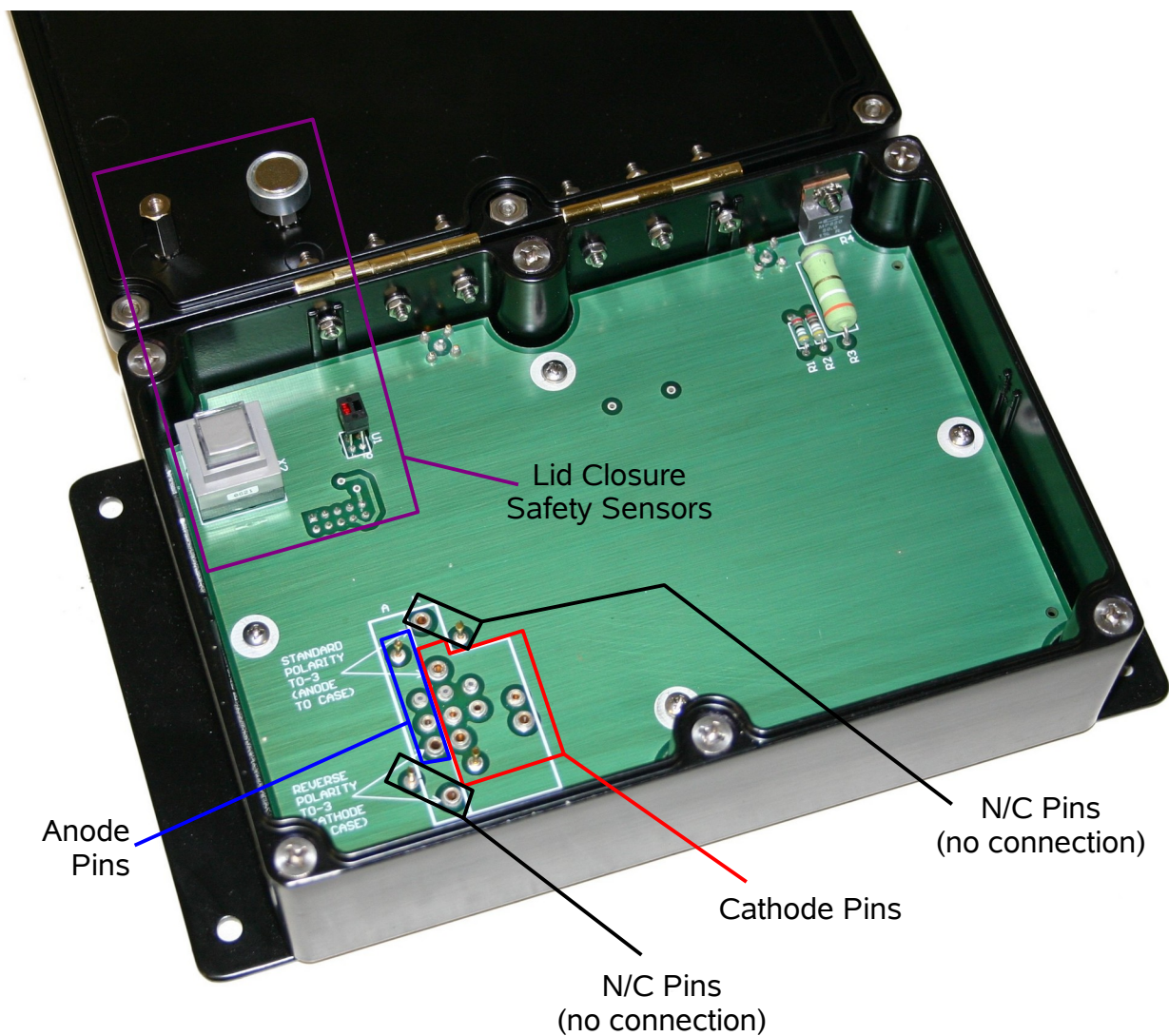

The instrument and the DUT will not be damaged if the diode is installed with the incorrect orientation (i.e., with the anode and cathode reversed). However, incorrect waveforms will be generated.

The procedure for inserting most axial and TO-220 packages is straightforward. Simply insert the DUT between one of the Anode pin sockets (in the blue area above) and one of the Cathode sockets (in the red area above). Select the sockets with the most appropriate hole size, and try to minimize all lead lengths, to minimize parasitic inductance.

This jig will also accommodate a number of TO-3 configurations, outlined below. If the case is connected to the anode, and the pin(s) are used for the cathode, the arrangement shown below must be used:

This socket and spring pin provide mechanical support only. They are not electrically active.

This spring pin must contact the underside of the case. It provides the anode connection.

The cathode pin of interest must be inserted into this socket. For dual-diode devices, rotate the TO-3 package so that the desired diode cathode is inserted here.

**For TO-3 packages
with Case = Anode**

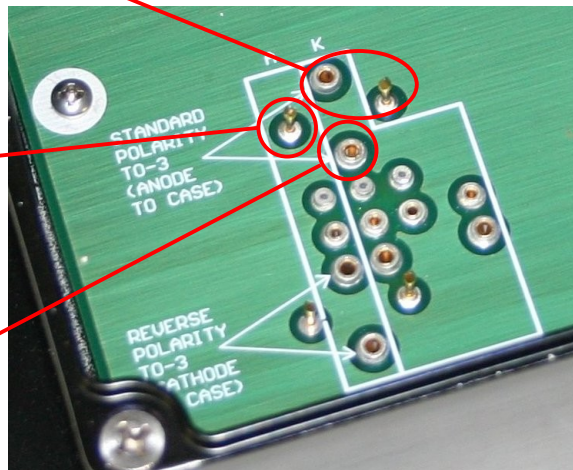

If the case is connected to the cathode, and the pin(s) are used for the anode, the arrangement shown below must be used:

**For TO-3 packages
with Case = Cathode**

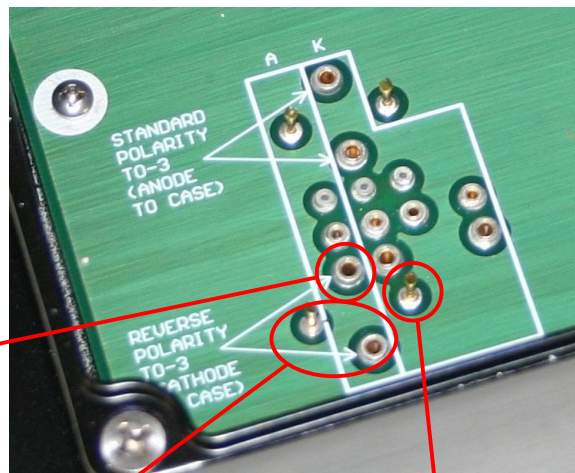

The anode pin of interest must be inserted into this socket. For dual-diode devices, rotate the TO-3 package so that the desired diode anode is inserted here.

This socket and spring pin provide mechanical support only. They are not electrically active.

This spring pin must contact the underside of the case. It provides the cathode connection.

The IN, OUT, and CONTROL connectors are on the rear of the jig, below the hinges:



LEAD BENDING

When inserting axial-leaded devices into the AVX-TRRA, lead bending is required.

For applications where this is undesirable, Avtech can provide an alternative test jig (model AVX-TRR-ANB) that accepts DO-41 / Type E axial packages (only), without any leading bending or trimming. Contact Avtech (info@avtechpulse.com) for details.

TYPICAL RESULTS

Obtaining meaningful results with the AVR-EB5-B requires care, experience, and an understanding of diode transient behavior and the impact of inductive and capacitive parasitics. To assist the user, typical results for commercially available diodes are provided below. The user should be able to reliably duplicate these results.

UM2106B RESULTS

The Microsemi UM2106B is a 600V axial-package PIN diode with a specified typical lifetime of 25 us.

With this diode installed in the AVX-TRRA test jig, AMP1 = +10 mA, and AMP2 = -200V, the following output waveform was obtained at the test jig "OUT" terminal:

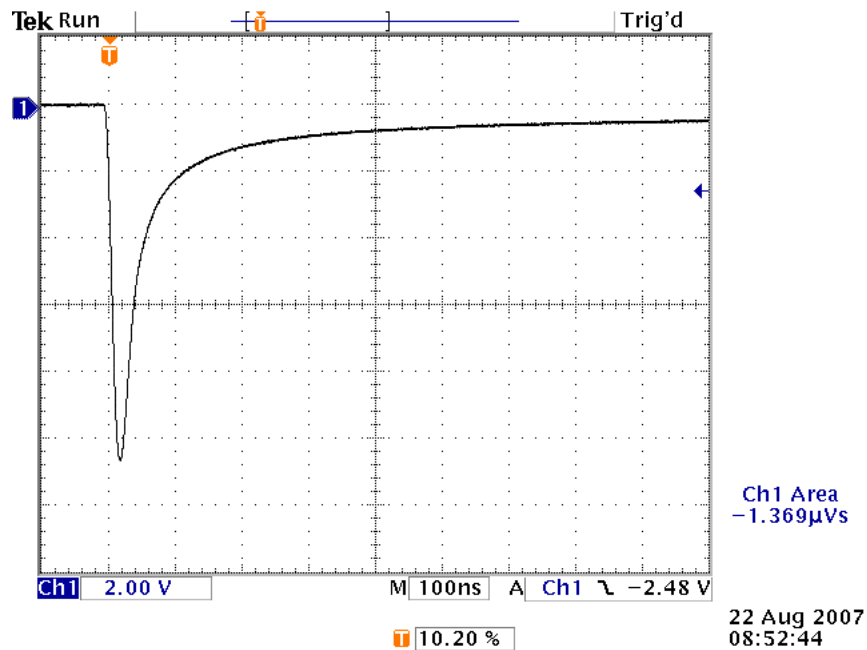

The oscilloscope measures a curve area of -1.369 V×us. However, the full tail of the transient is not captured at this time scale, so a second waveform must be recorded:

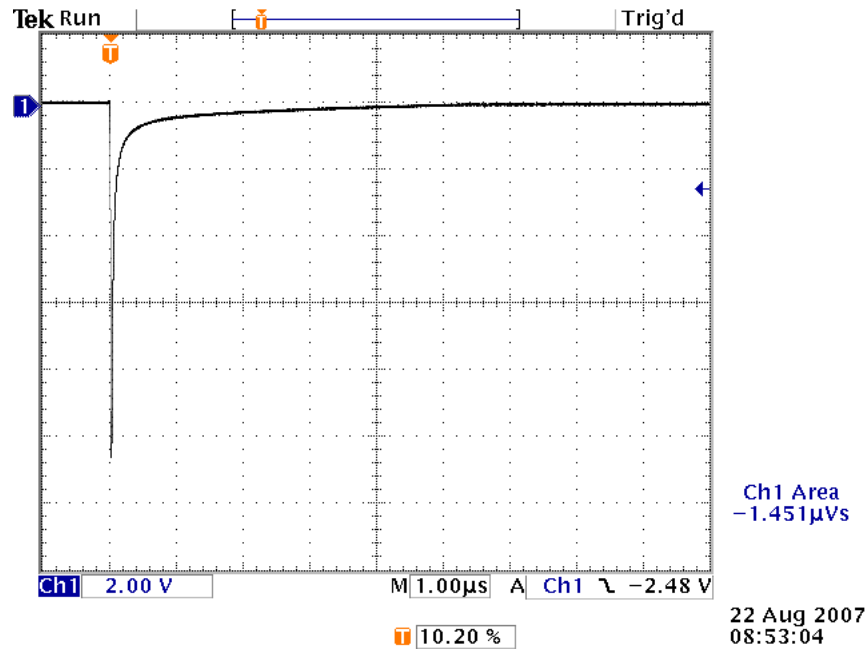

This waveform appears to show the transient tapering off to zero, and gives a slightly higher area of $-1.451 \text{ V}\times\text{us}$. Since

$$V_{\text{OUT}} = I_{\text{DUT}} \times 5\Omega$$

the charge can be estimated as:

$$Q \approx A = 1.451 \text{ V}\times\text{us} / 5\Omega$$

$$Q \approx 0.290 \text{ A}\times\text{us}$$

Since

$$Q = I_{\text{F}} \times \tau$$

$$\tau \approx 0.290 \text{ A}\times\text{us} / 10 \text{ mA}$$

$$\tau \approx 29.0 \text{ us}$$

which agrees well with the specified typical value of 25 us.

For this test, the UM2016B was installed as shown below:

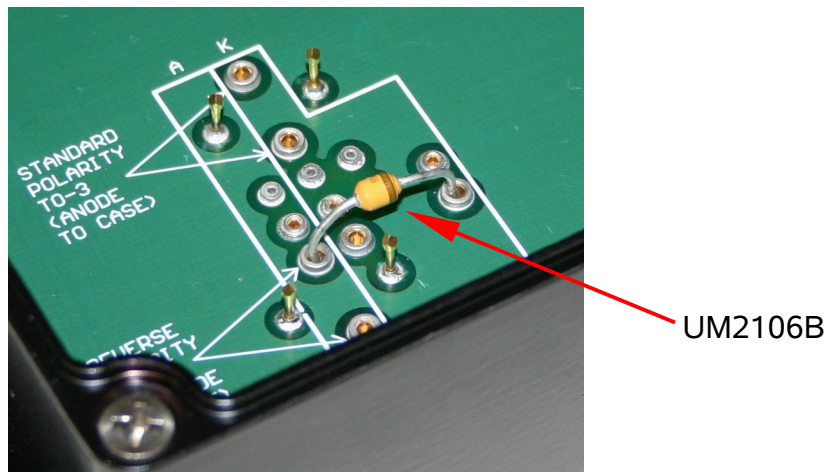

HUM3003 RESULTS

The Microsemi HUM3003 is a high-power 3 kV DO-4 stud-packaged diode with a rated lifetime of 30 us, typically. It was tested with amplitudes set to +10 mA and -200V, using the AVX-TRR-MSB-STUD test jig. The following reverse recovery waveform was obtained at the test jig "OUT" terminal:

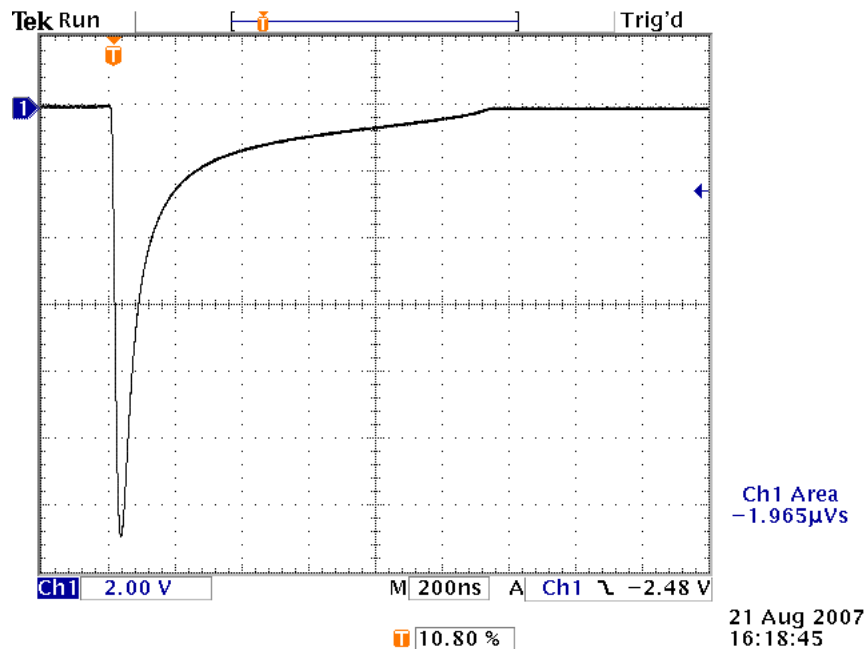

From $A = -1.965 \text{ V} \times \mu\text{s}$, we calculate $\tau \approx 39.3 \text{ us}$ (compared to the rated typical lifetime of 30 us).

For this test, the HUM3003 was installed as shown below:

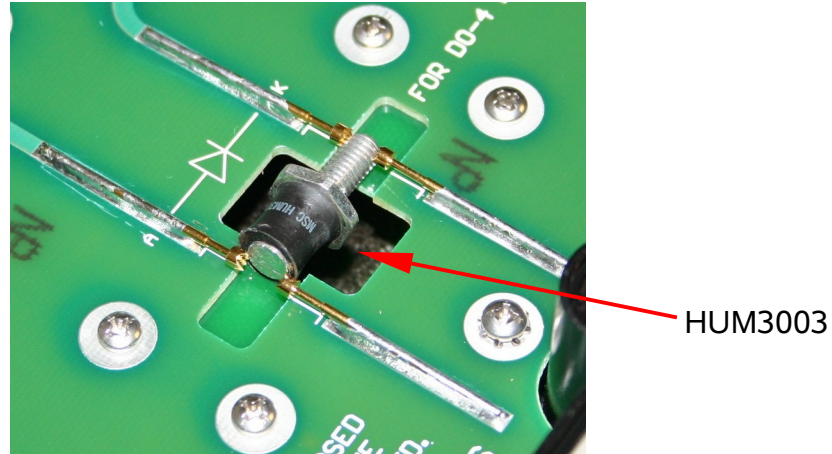

UM7102B RESULTS

The Microsemi UM7102B has a lower lifetime compared to the other two test diodes. This axial diode is rated at 200V and 2.0 us. It was tested with amplitudes set to +10 mA and -200V, using the AVX-TRRA test jig. The following reverse recovery waveform was obtained at the test jig "OUT" terminal:

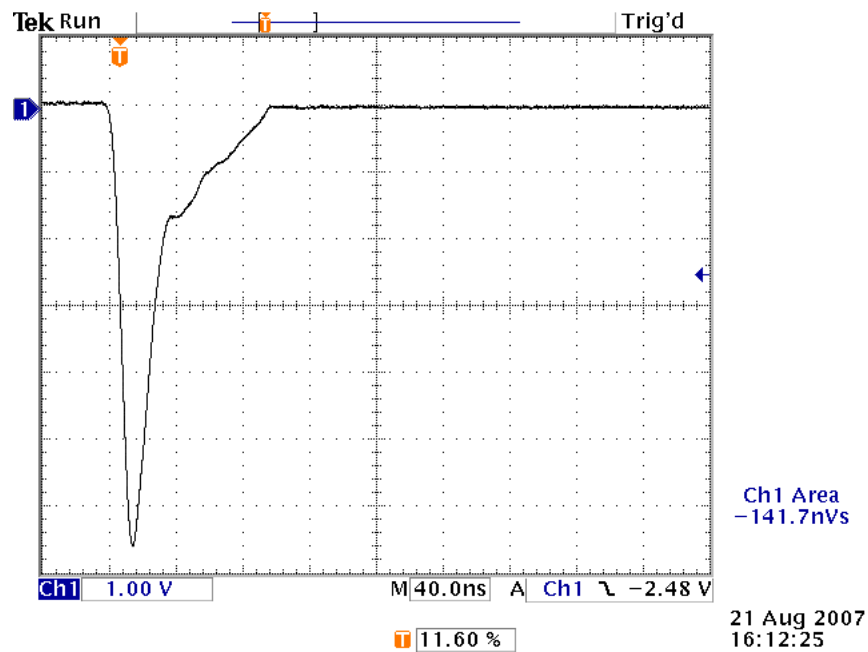

From $A = -141.7 \text{ V}\times\text{ns}$, we calculate $\tau \approx 2.8 \text{ us}$ (compared to the rated typical lifetime of 2.0 us).

CUSTOMIZED TEST JIGS

MELF PACKAGES

Certain customized test jigs accept MELF (Metal Electrode Leadless Face) type SMT packages. This includes the AVX-TRR-SCHA and AVX-TRR-MSB-MELF test jigs.

These test jigs use spring-loaded probe pins to contact the device under test. The connection arrangement is the same as for the standard test jig.

The test jig is shown below:



The device under test may be inserted between to spring-loaded pins. These pins are shown below:



Anode spring pin

Cathode spring pin

The next photo shows a MELF device installed between the two pins:



A MELF-packaged
Device Under Test (DUT)

CHIP-LEVEL TESTS

Certain customized test jigs accept chip-level packages. This includes the AVX-TRR-MSB-MELF test jig.

These test jigs use spring-loaded flat-headed probe pins to contact the device under test. The connection arrangement is the same as for the standard test jig. An example of this arrangement is shown below:

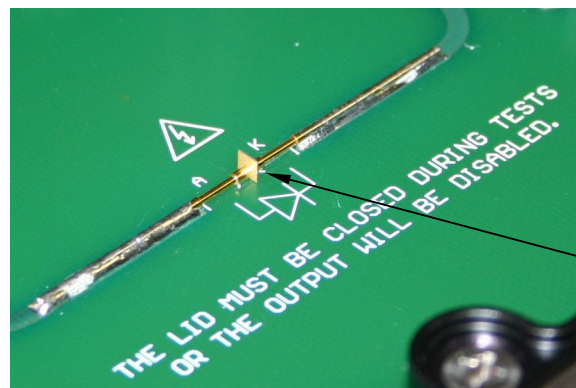

A chip DUT
sandwiched between
the two flat-headed
spring pins.

DO-4 AND DO-5 STUD PACKAGES

Certain customized test jigs accept DO-4 AND DO-5 standard and reverse-polarity stud packages. This includes the AVX-TRR-MSB-STUD test jig. This test jig is shown below:



The photo below shows a reverse-polarity DO-4 diode (the Ruttonsha 12FLR60/F05) installed between the four spring-loaded contacts (two for the anode end, and two for the cathode end):

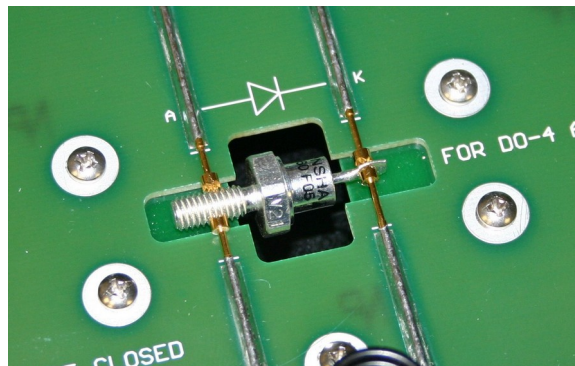

To install the diode, spread apart one pair of spring pins with your fingers or tweezers, and insert one end of the diode. Repeat on the other end.

The photo below shows a reverse-polarity DO-5 diode (the Ruttonsha 40HF80) installed between the four spring-loaded contacts (two for the anode end, and two for the cathode end):

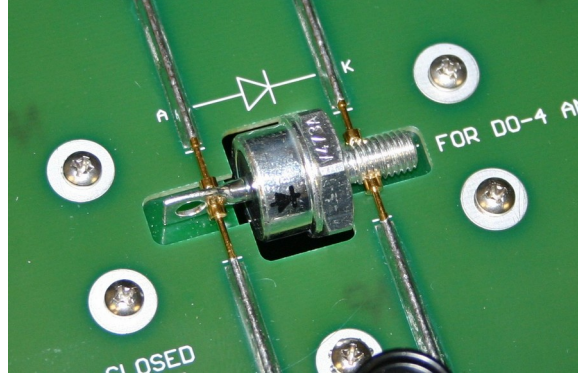

TROUBLESHOOTING

If you obtain “strange” output waveforms, or unexpected values of t_{RR} , keep these points in mind:

- 1) The test jig output *must* be terminated with 50 Ohms.
- 2) The test jig lid must be closed, or the pulser output will be disabled.

For technical support, contact info@avtechpulse.com. Sample waveforms and digital photos of your setup are always helpful!

PROGRAMMING YOUR PULSE GENERATOR

KEY PROGRAMMING COMMANDS

The “Programming Manual for -B Instruments” describes in detail how to connect the pulse generator to your computer, and the programming commands themselves. A large number of commands are available; however, normally you will only need a few of these. Here is a basic sample sequence of commands that might be sent to the instrument after power-up:

*rst	(resets the instrument)
trigger:source internal	(selects internal triggering)
frequency 10 Hz	(sets the frequency to 10 Hz)
pulse:delay 1 us	(sets the delay to 1 us)
pulse:width1 100 us	(sets the positive pulse width to 100 us)
pulse:width2 500 us	(sets the negative pulse width to 500 us)
curr1 +10mA	(sets the positive pulse amplitude to +10 mA)
volt2 -200V	(sets the negative pulse amplitude to -200 V)
output on	(turns on the output)

For triggering a single event, this sequence would be more appropriate:

*rst	(resets the instrument)
trigger:source hold	(turns off all triggering)
output on	(turns on the output)
pulse:delay 1 us	(sets the delay to 1 us)
pulse:width1 100 us	(sets the positive pulse width to 100 us)
pulse:width2 500 us	(sets the negative pulse width to 500 us)
curr1 +10mA	(sets the positive pulse amplitude to +10 mA)
volt2 -200V	(sets the negative pulse amplitude to -200 V)
trigger:source immediate	(generates a single non-repetitive trigger event)
trigger:source hold	(turns off all triggering)
output off	(turns off the output)

To set the instrument to trigger from an external TTL signal applied to the rear-panel TRlg connector, use:

*rst	(resets the instrument)
trigger:source external	(selects external triggering)
pulse:delay 1 us	(sets the delay to 1 us)
pulse:width1 100 us	(sets the positive pulse width to 100 us)
pulse:width2 500 us	(sets the negative pulse width to 500 us)
curr1 +10mA	(sets the positive pulse amplitude to +10 mA)
volt2 -200V	(sets the negative pulse amplitude to -200 V)
output on	(turns on the output)

These commands will satisfy 90% of your programming needs.

ALL PROGRAMMING COMMANDS

For more advanced programmers, a complete list of the available commands is given below. These commands are described in detail in the “Programming Manual for -B Instruments”. (Note: this manual also includes some commands that are not implemented in this instrument. They can be ignored.)

<u>Keyword</u>	<u>Parameter</u>	<u>Notes</u>
LOCAL		
OUTPut:		
:[STATe]	<boolean value>	
:PROTection		
:TRIPped?		[query only]
REMOTE		
[SOURce]:		
:FREQuency		
[:CW FIXed]	<numeric value>	
[SOURce]:		
:PULSe		
:PERiod	<numeric value>	
:WIDTh	<numeric value>	
:DELay	<numeric value>	
:GATE		
:LEVel	High LOw	
[SOURce]:		
:VOLTage		
[:LEVel]		
[:IMMediate]		
[:AMPLitude]	<numeric value>	
:PROTection		
:TRIPped?		[query only]
STATUS:		
:OPERation		
:[EVENT]?		[query only, always returns "0"]
:CONDition?		[query only, always returns "0"]
:ENABle	<numeric value>	[implemented but not useful]
:QUEStionable		
:[EVENT]?		[query only, always returns "0"]
:CONDition?		[query only, always returns "0"]
:ENABle	<numeric value>	[implemented but not useful]
SYSTEM:		
:COMMunicate		
:GPIB		
:ADDReSS	<numeric value>	
:SERial		
:CONTRol		
:RTS	ON IBFull RFR	
:[RECeive]		
:BAUD	1200 2400 4800 9600	

:BITS	7 8	
:ECHO	<boolean value>	
:PARity		
:[TYPE]	EVEN ODD NONE	
:SBITS	1 2	
:ERRor		
:[NEXT]?		[query only]
:COUNT?		[query only]
:VERSion?		[query only]
TRIGger:		
:SOURce	INTernal EXTernal MANual HOLD IMMEDIATE	
*CLS		[no query form]
*ESE	<numeric value>	
*ESR?		[query only]
*IDN?		[query only]
*OPC		
*SAV	0 1 2 3	[no query form]
*RCL	0 1 2 3	[no query form]
*RST		[no query form]
*SRE	<numeric value>	
*STB?		[query only]
*TST?		[query only]
*WAI		[no query form]

MECHANICAL INFORMATION

TOP COVER REMOVAL

If necessary, the interior of the instrument may be accessed by removing the four Phillips screws on the top panel. With the four screws removed, the top cover may be slid back (and off).

 Always disconnect the power cord and allow the instrument to sit unpowered for 10 minutes before opening the instrument. This will allow any internal stored charge to discharge.

There are no user-adjustable internal circuits. For repairs other than fuse replacement, please contact Avtech (info@avtechpulse.com) to arrange for the instrument to be returned to the factory for repair. Service is to be performed solely by qualified service personnel.

 Caution: High voltages are present inside the instrument during normal operation. Do not operate the instrument with the cover removed.

RACK MOUNTING

A rack mounting kit is available. The -R5 rack mount kit may be installed after first removing the one Phillips screw on the side panel adjacent to the front handle.

ELECTROMAGNETIC INTERFERENCE

To prevent electromagnetic interference with other equipment, all used outputs should be connected to shielded loads using shielded coaxial cables. Unused outputs should be terminated with shielded coaxial terminators or with shielded coaxial dust caps, to prevent unintentional electromagnetic radiation. All cords and cables should be less than 3m in length.

MAINTENANCE

REGULAR MAINTENANCE

This instrument does not require any regular maintenance.

On occasion, one or more of the four rear-panel fuses may require replacement. All fuses can be accessed from the rear panel. See the “FUSES” section for details.

CLEANING

If desired, the interior of the instrument may be cleaned using compressed air to dislodge any accumulated dust. (See the “TOP COVER REMOVAL” section for instructions on accessing the interior.) No other cleaning is recommended.

WIRING DIAGRAMS

WIRING OF AC POWER

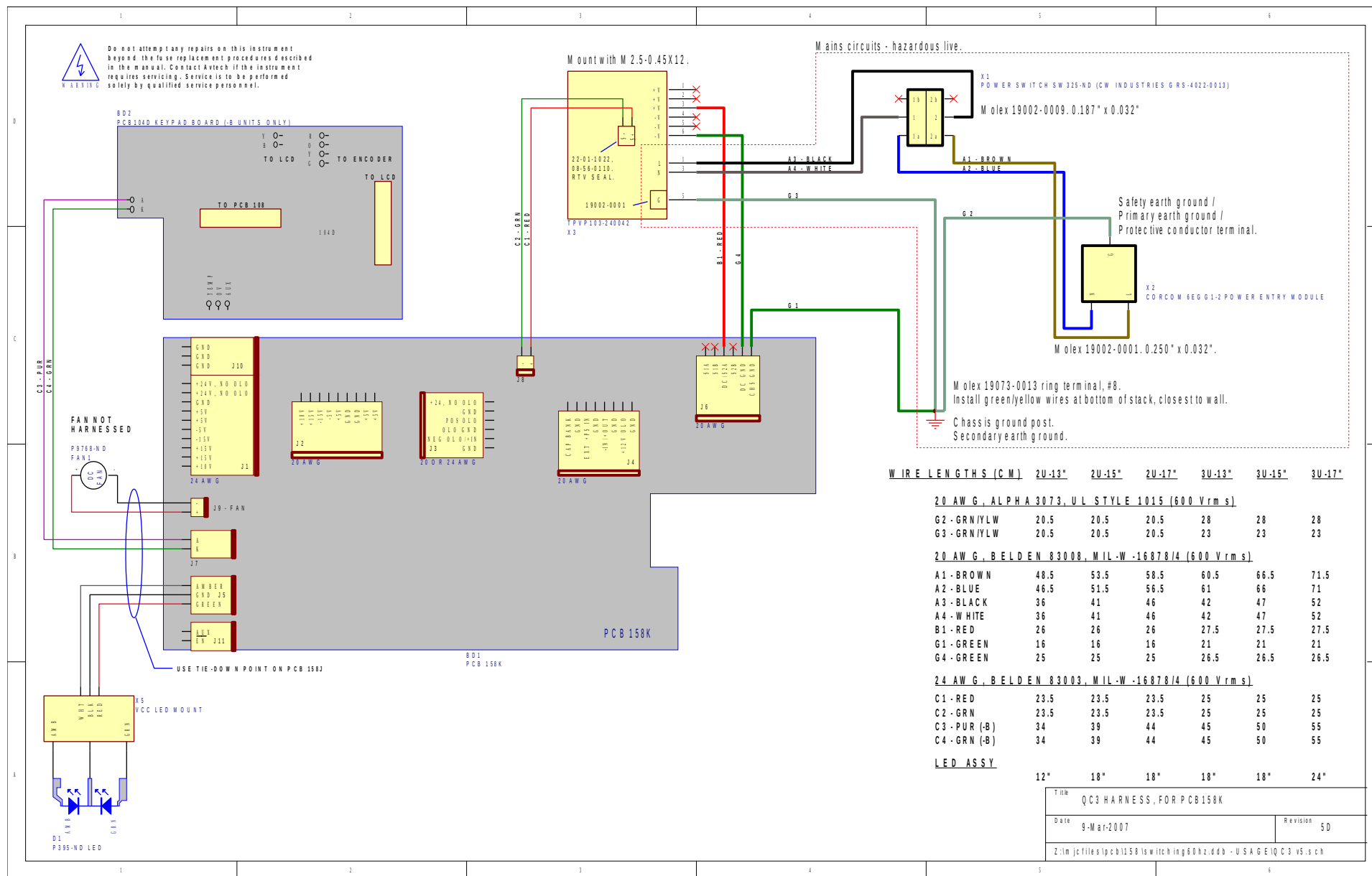

PCB 158K - LOW VOLTAGE POWER SUPPLY, 1/3

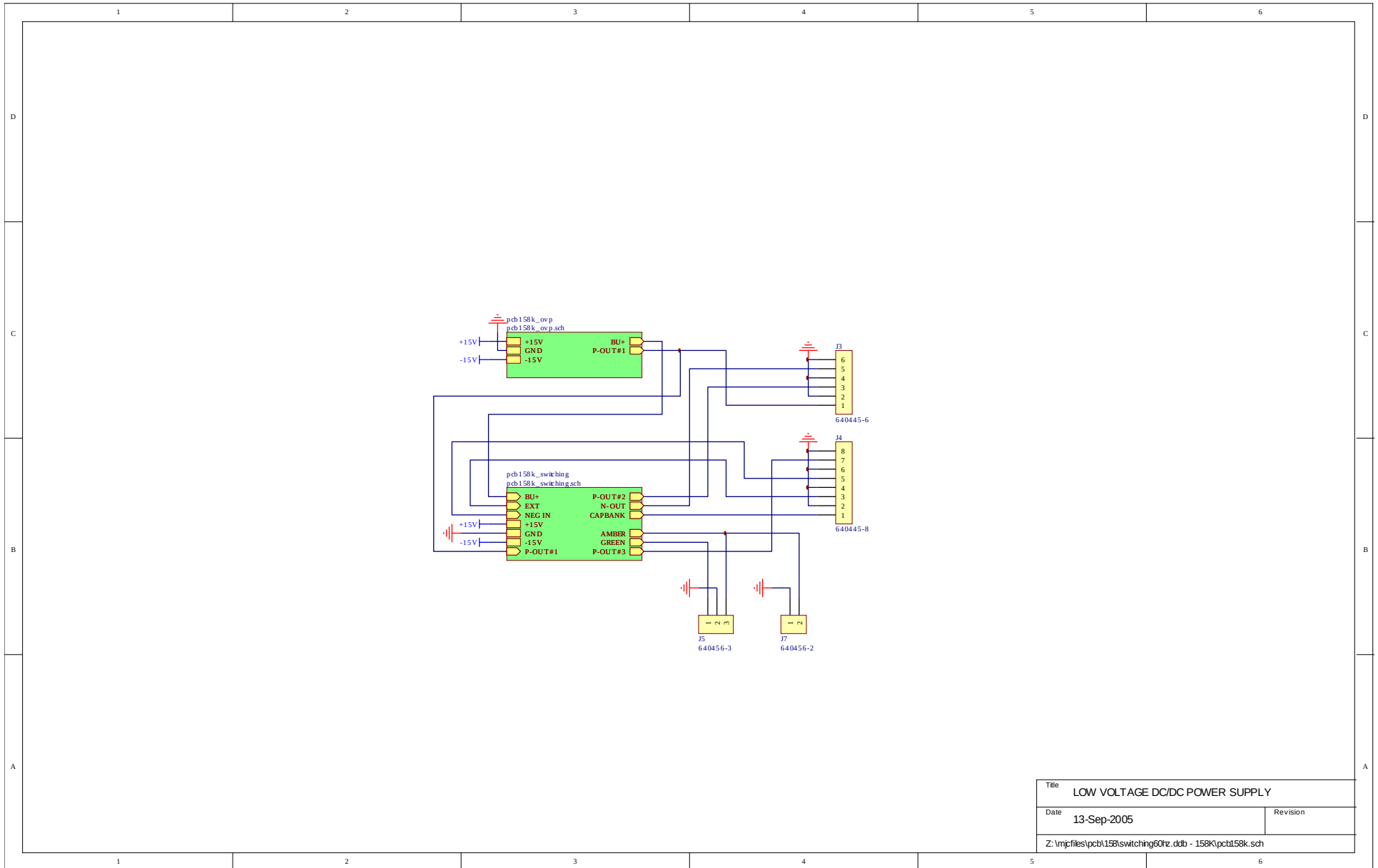

Title	LOW VOLTAGE DC/DC POWER SUPPLY	
Date	13-Sep-2005	Revision
Z:\mpjfiles\pcb158\switching01rz.ddb - 158K\pcb158k.sch		

PCB 158K - LOW VOLTAGE POWER SUPPLY, 2/3

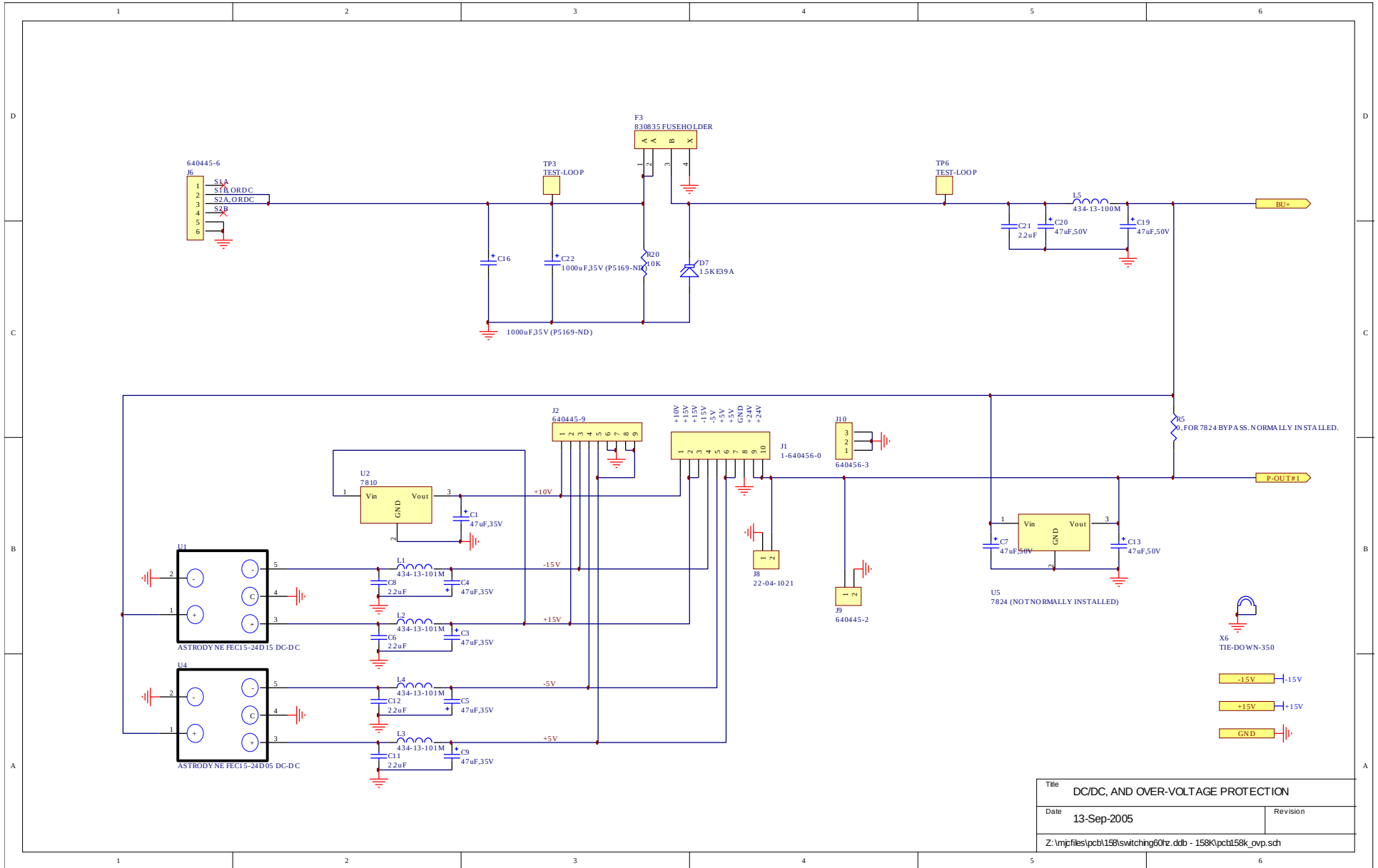

PCB 158K - LOW VOLTAGE POWER SUPPLY, 3/3

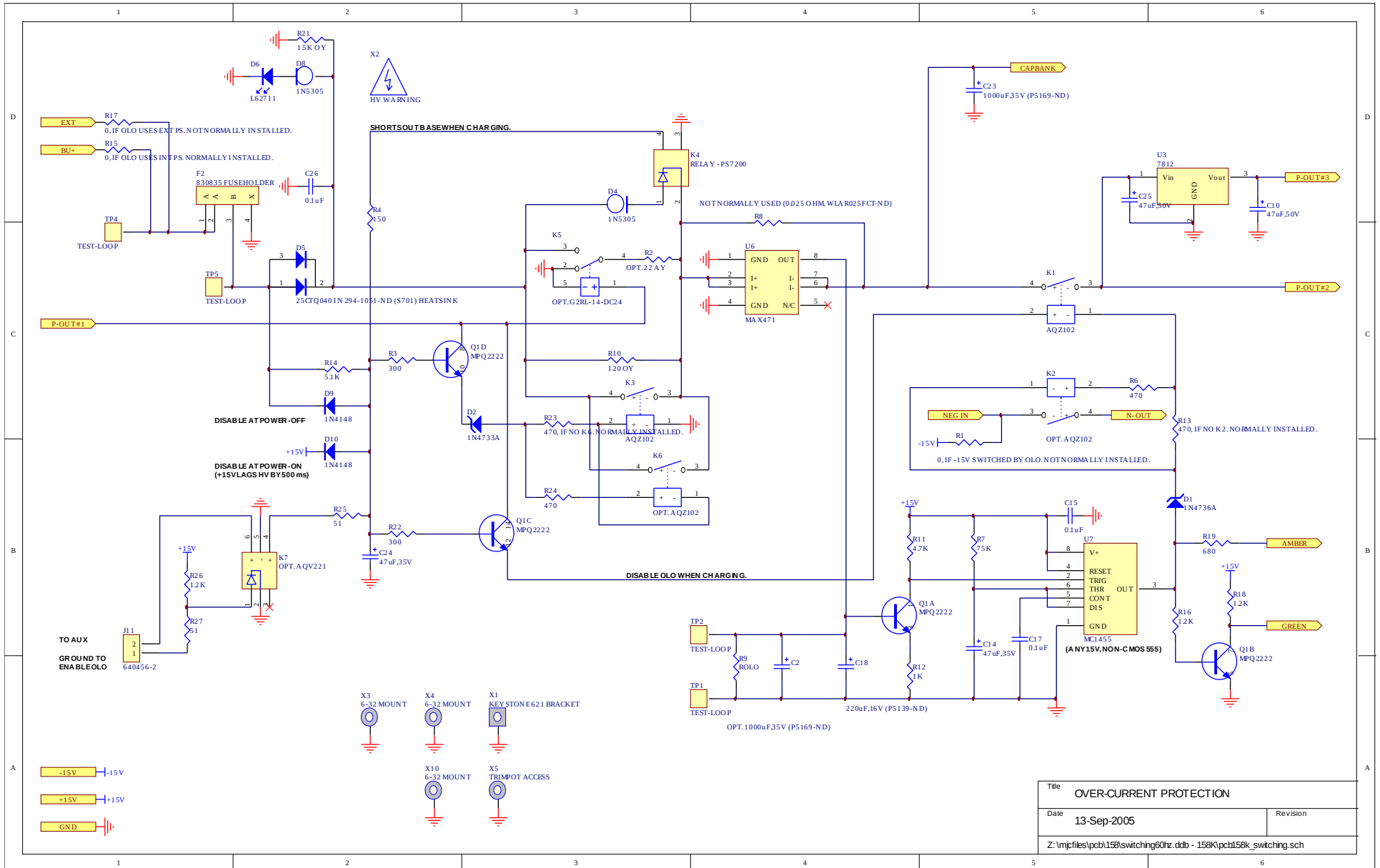

PCB 157C - HIGH VOLTAGE DC POWER SUPPLY

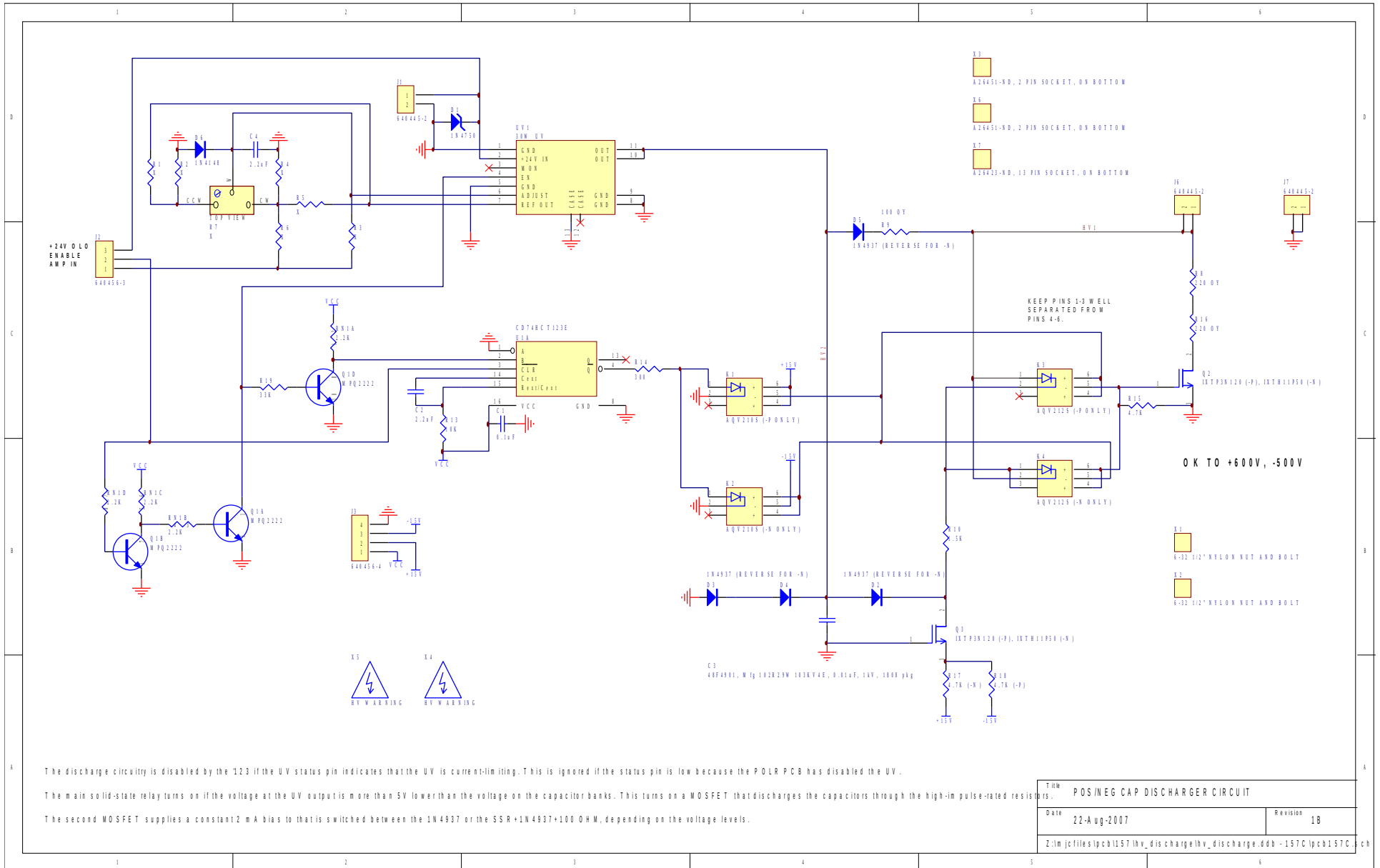

PCB 183A-S AND 183A-P CAPACITOR BANKS

183A-S (SERIES CAPACITOR BANK)

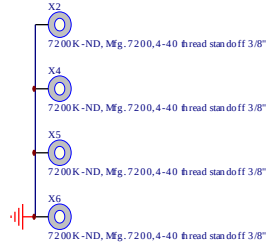
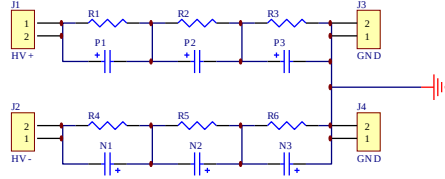

183A-P (PARALLEL CAPACITOR BANK)

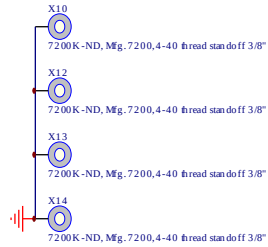
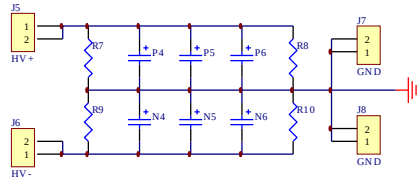

PCB183 CAP BANKS

Printed 19-Aug-2005

Revision 1C

Z:\mprojfiles\pcb183\hv-cap-bank.Dtb - pcb183a.sch

PCB 104D - KEYPAD / DISPLAY BOARD, 1/3

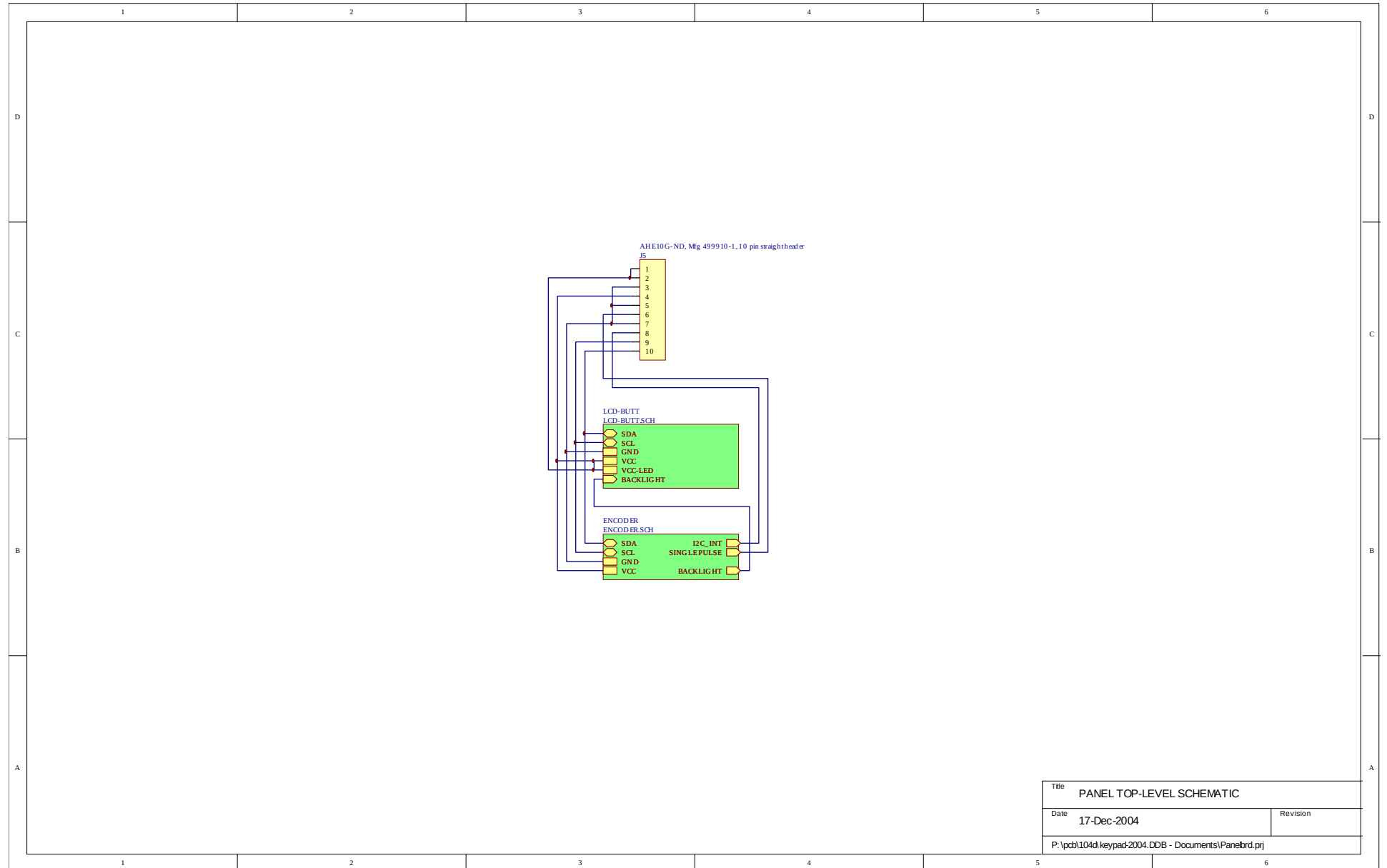

Title		PANEL TOP-LEVEL SCHEMATIC	
Date	17-Dec-2004	Revision	
P:\pcb\104d\keypad\2004.DDB - Documents\Panelbrd.prj			

PCB 104D - KEYPAD / DISPLAY BOARD, 2/3

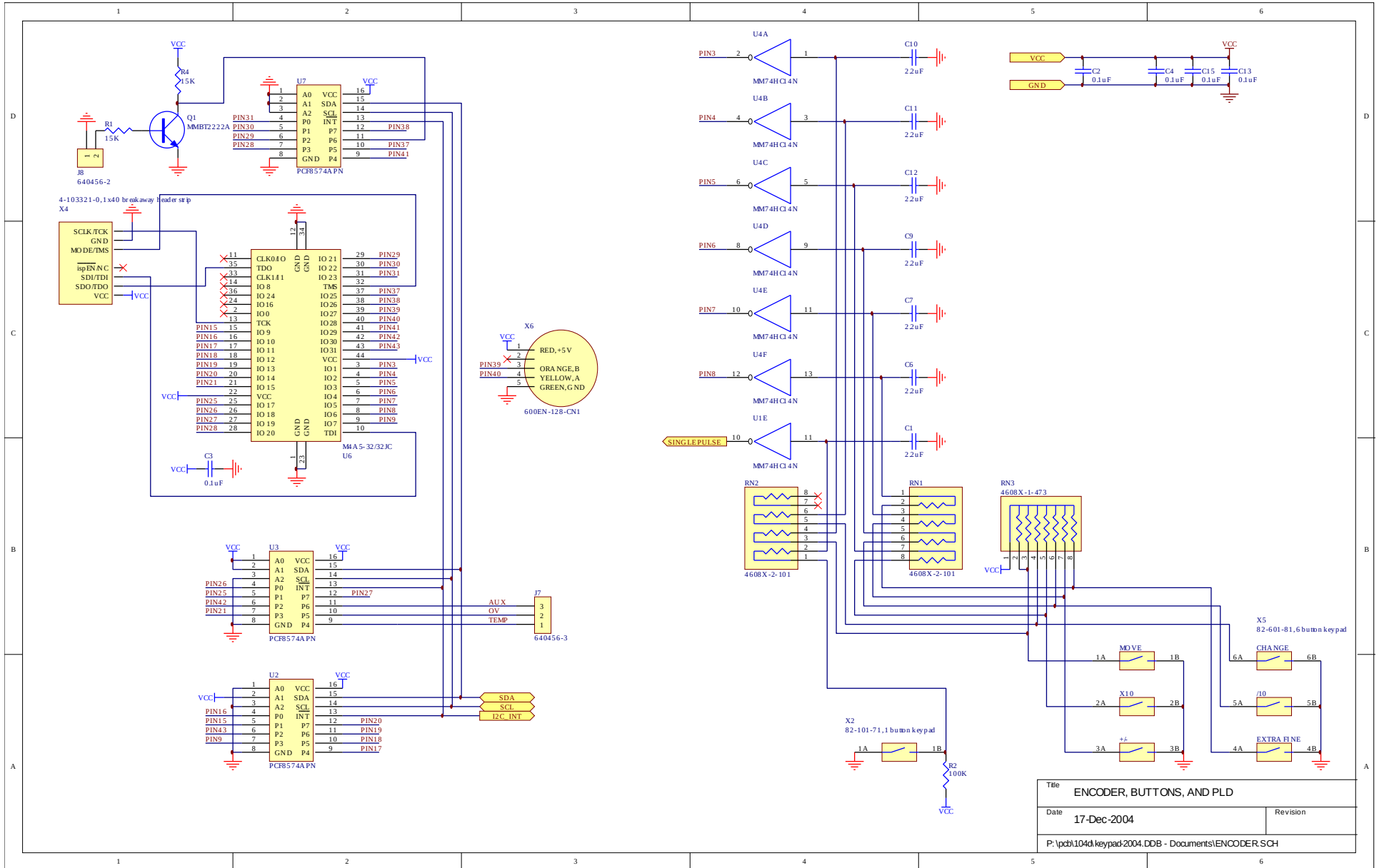

Title		ENCODER, BUTTONS, AND PLD
Date	17-Dec-2004	Revision
P:\pcb\104d\keypad\2004.DDB - Documents\ENCODER-SCH		

PCB 104D - KEYPAD / DISPLAY BOARD, 3/3

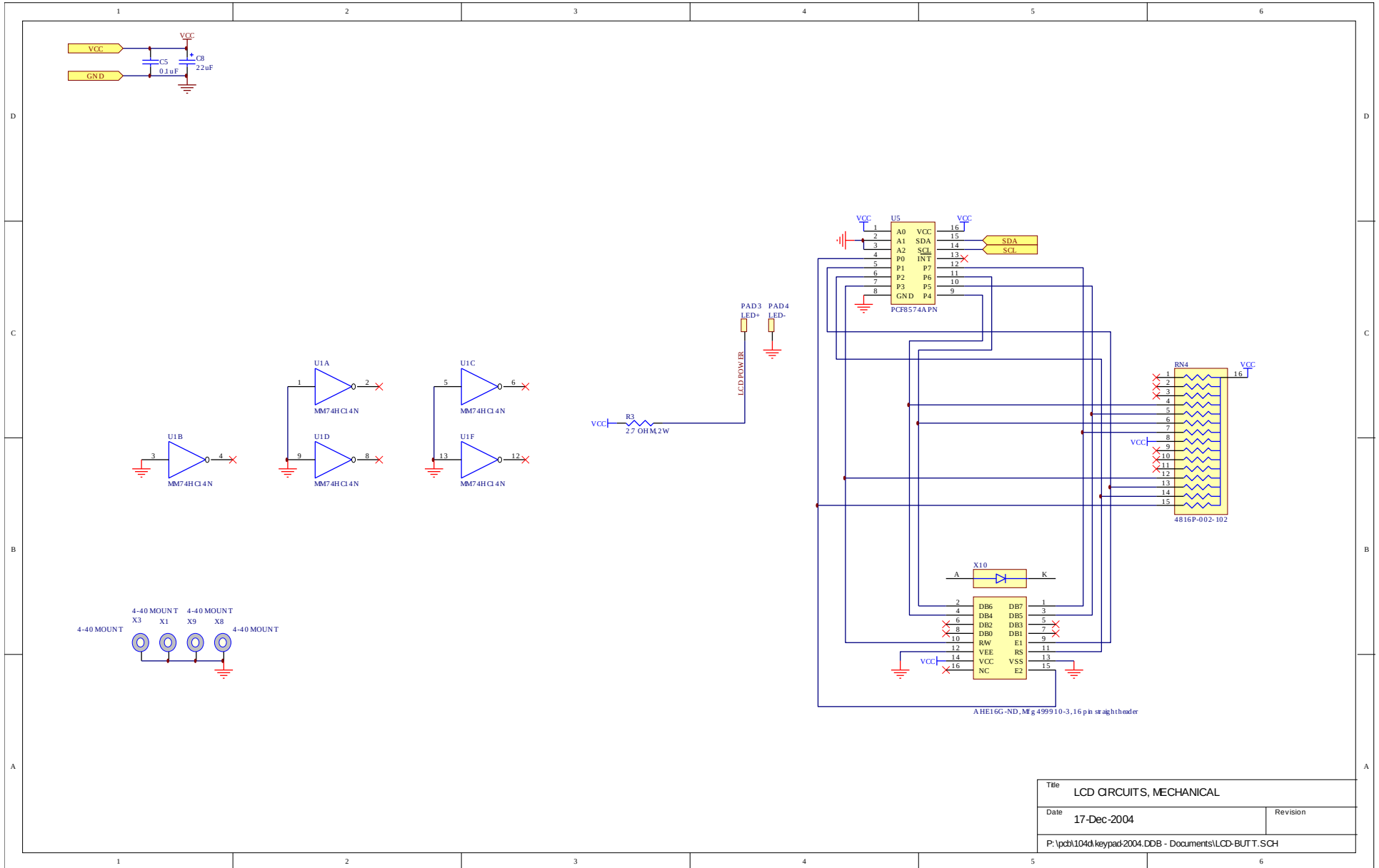

Title		LCD CIRCUITS, MECHANICAL	
Date	17-Dec-2004	Revision	
P:\pcb\104d\keypad2004.DDB - Documents\LCD-BUTT.SCH			

MAIN WIRING

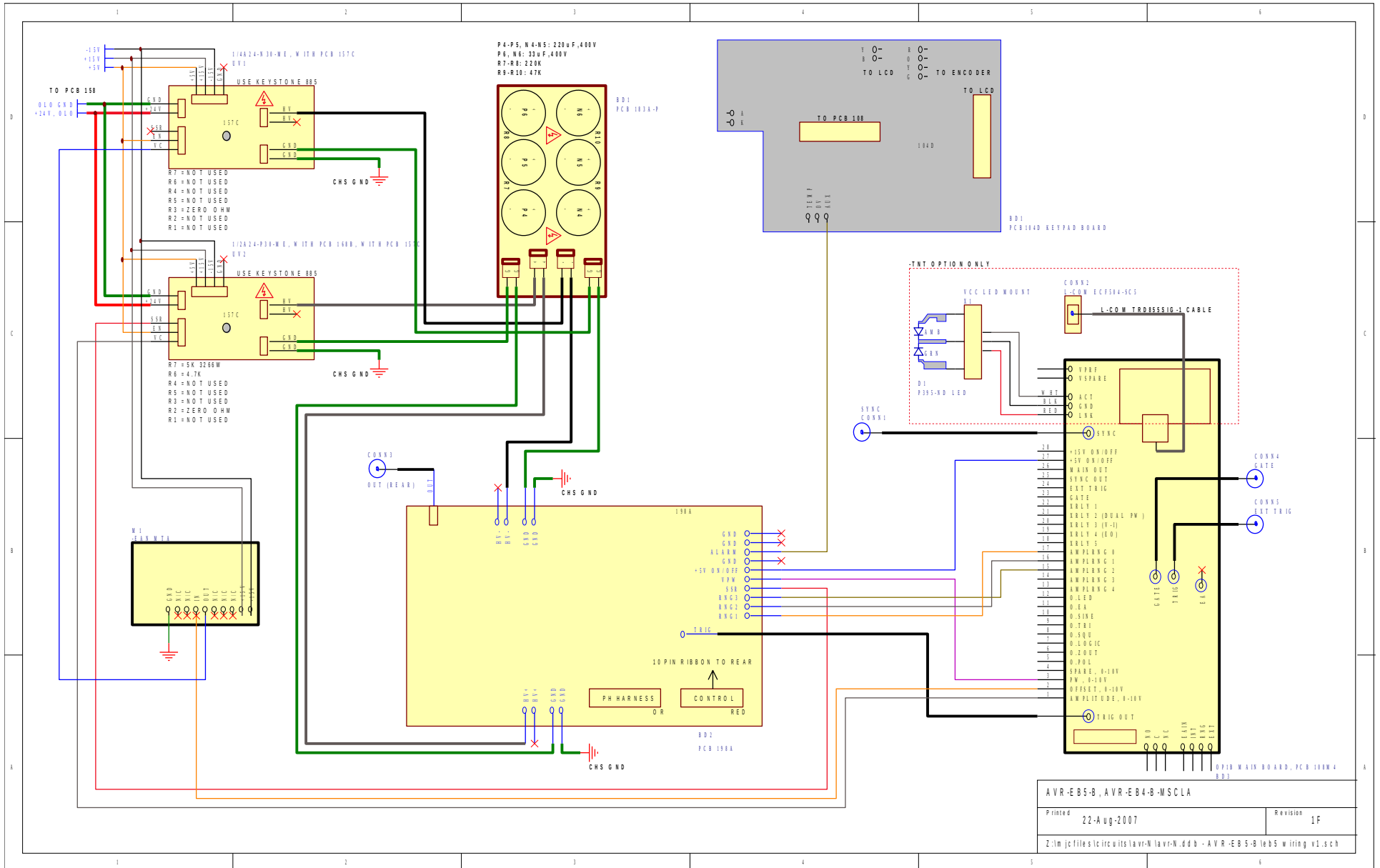

STANDARD TEST JIG WIRING (AVX-TRRA)

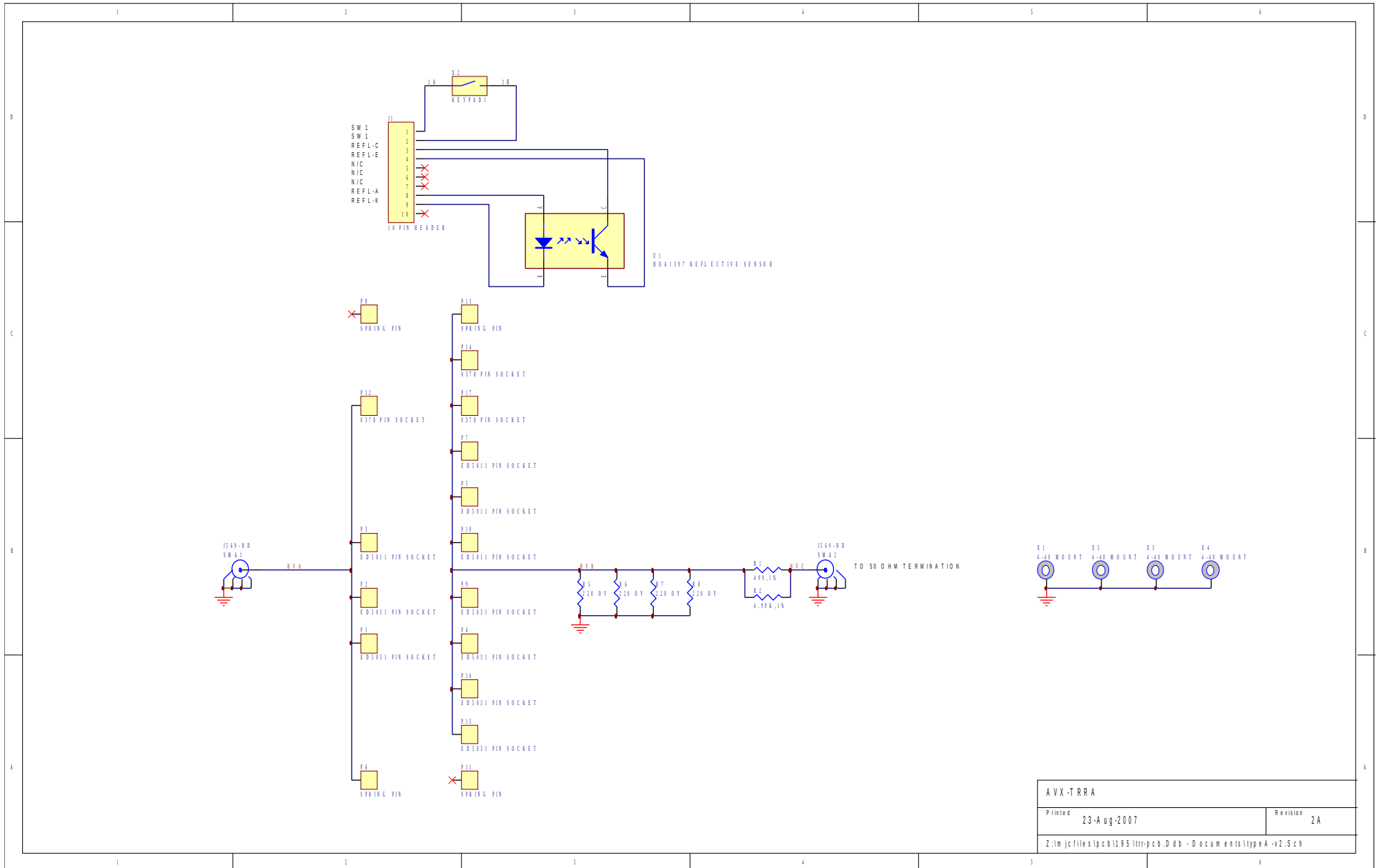

AVX-TRRA	
Printed 23-Aug-2007	Revision 2A
Z:\lm\jc\files\ipc\b1195\ltrr-pcb.Ddb - Documents\typeA-v2.Sch	

TEST JIG WIRING (AVX-TRR-MSB-MELF)

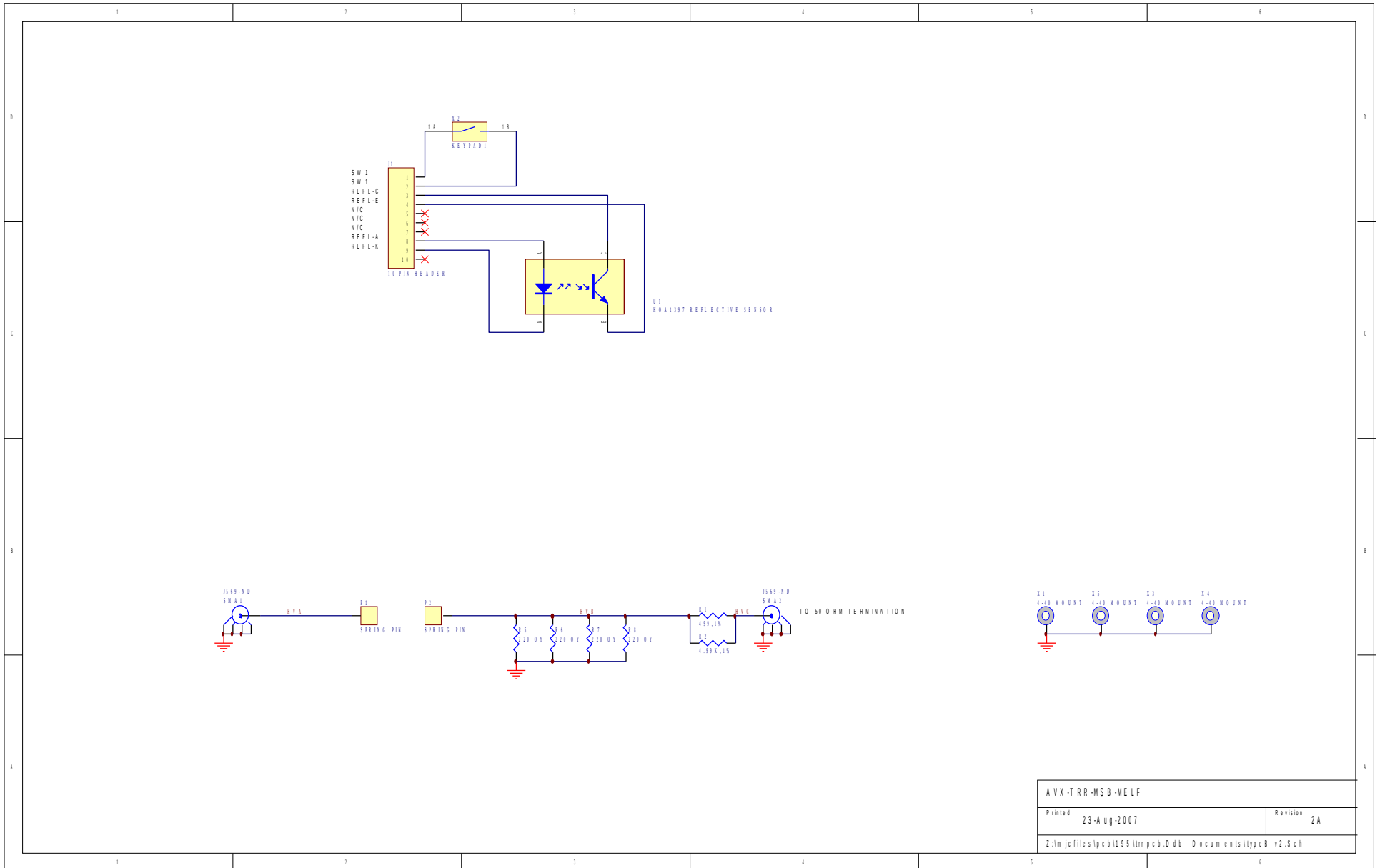

AVX-TRR-MSB-MELF	
Printed 23-Aug-2007	Revision 2A
Z:\m\jc\files\pcb\1195\trr-pcb.Ddb - Documents\typeB-v2.Sch	

TEST JIG WIRING (AVX-TRR-MSB-STUD)

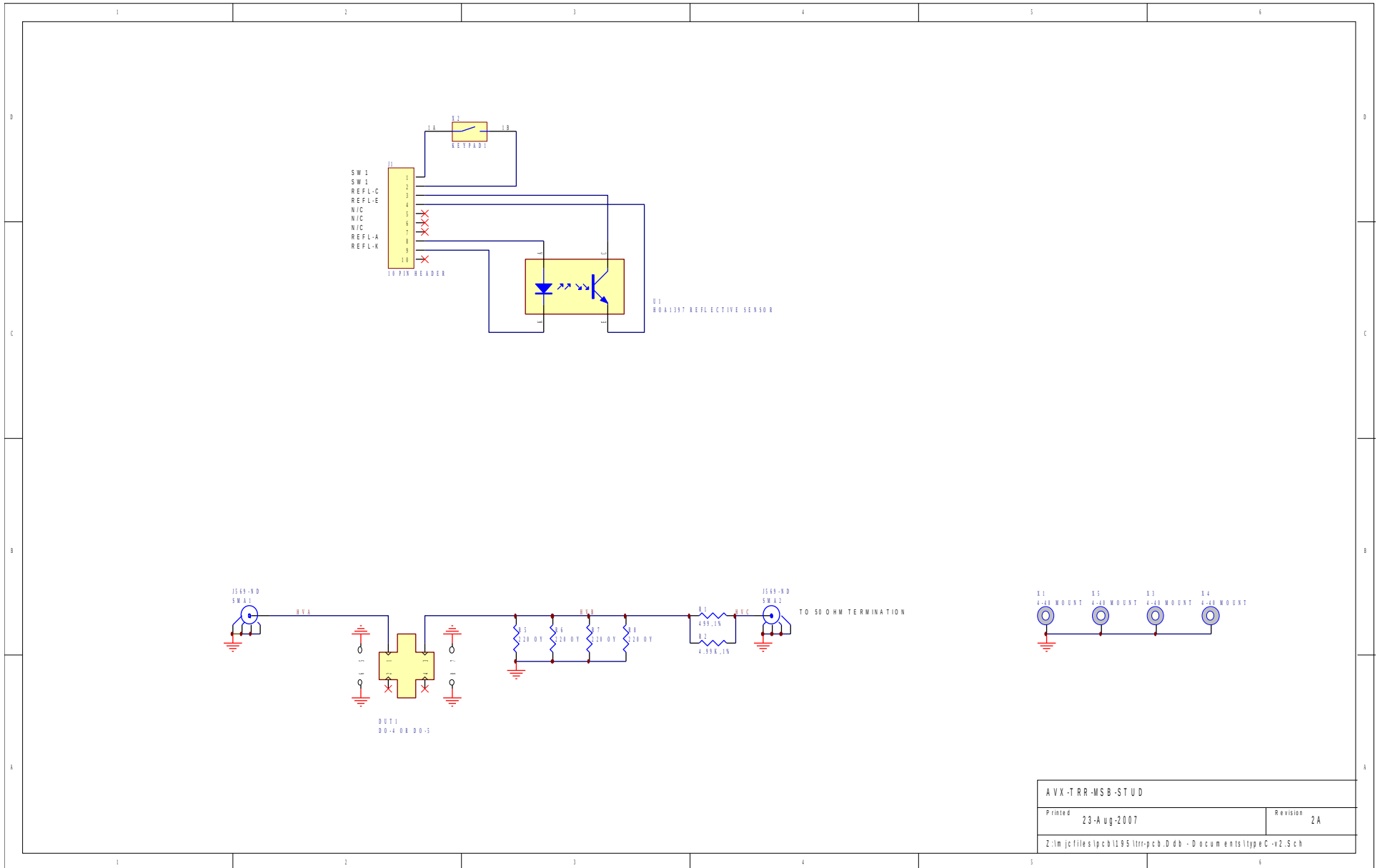

AVX-TRR-MSB-STUD	
Printed 23-Aug-2007	Revision 2A
Z:\m\jc\files\pcb\1195\trr-pcb.Ddb - Documents\typeC-v2.Sch	

TEST JIG WIRING (AVX-TRR-ANB)

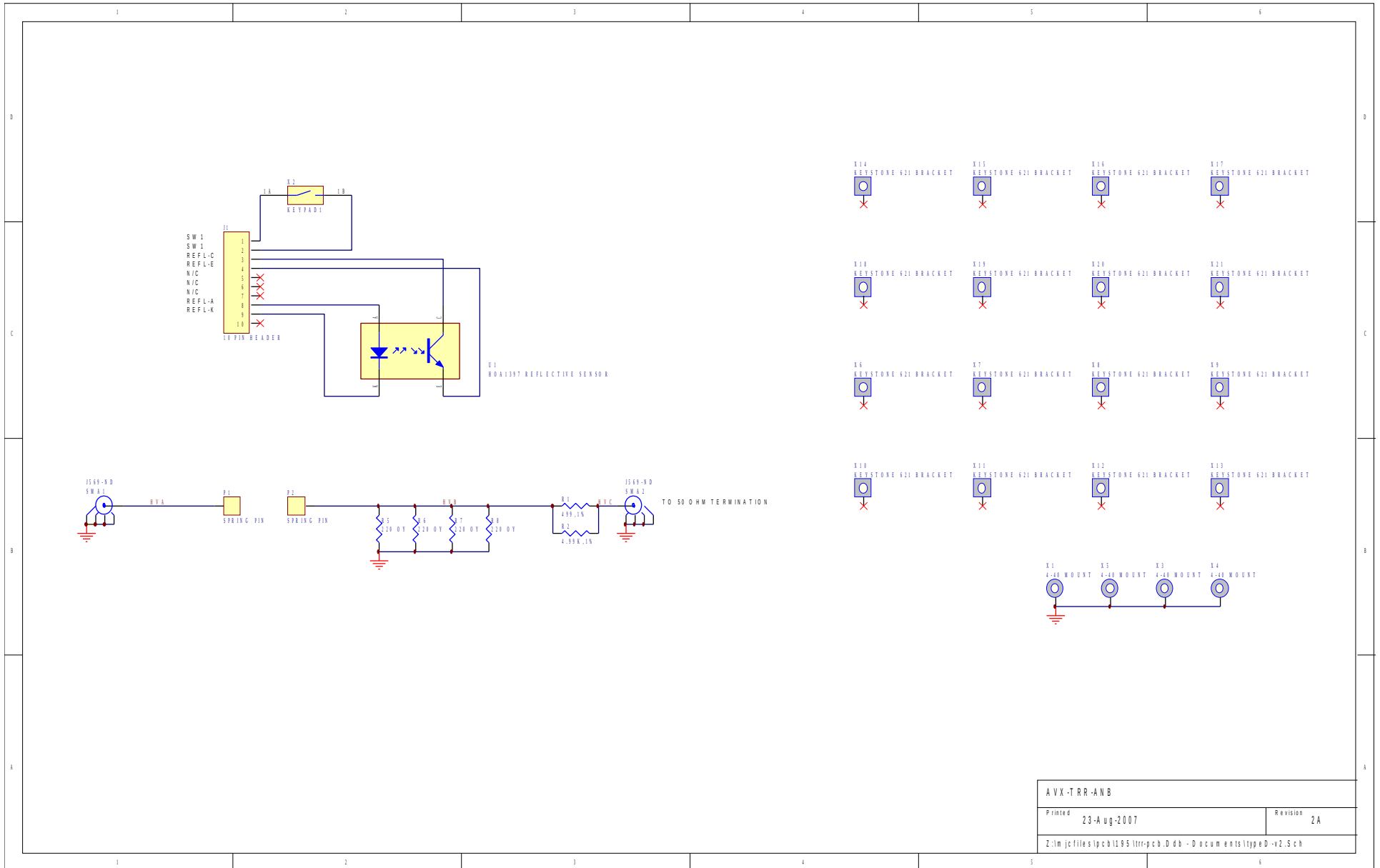

AVX-TRR-ANB	
Printed	23-Aug-2007
Revision	2A
Z:\m\jc\files\ipc\b1195\trr-pcb.Ddb - Documents\ltypeD-v2.Sch	

PERFORMANCE CHECK SHEET