

INSTRUCTIONS

MODEL AVRH-3-PS-PN PULSE GENERATOR

S.N.:

WARRANTY

Avtech Electrosystems Ltd. warrants products of its manufacture to be free from defects in material and workmanship under conditions of normal use. If, within one year after delivery to the original owner, and after prepaid return by the original owner, this Avtech product is found to be defective, Avtech shall at its option repair or replace said defective item. This warranty does not apply to units which have been disassembled, modified or subjected to conditions exceeding the applicable specifications or ratings. This warranty is the extent of the obligation assumed by Avtech with respect to this product and no other warranty or guarantee is either expressed or implied.

TECHNICAL SUPPORT

Phone: 613-226-5772 or 1-800-265-6681

Fax: 613-226-2802 or 1-800-561-1970

E-mail: info@avtechpulse.com

World Wide Web: <http://www.avtechpulse.com>

TABLE OF CONTENTS

WARRANTY.....	2
TABLE OF CONTENTS.....	4
FIG. 1: PULSE GENERATOR TEST ARRANGEMENT.....	5
GENERAL OPERATING INSTRUCTIONS.....	6
FIG. 2: FRONT PANEL CONTROLS.....	8
FRONT PANEL CONTROLS.....	9
FIG. 3: BACK PANEL CONTROLS.....	10
BACK PANEL CONTROLS.....	11
TOP COVER REMOVAL AND RACK MOUNTING.....	12
SYSTEM DESCRIPTION AND REPAIR PROCEDURE.....	13
PERFORMANCE CHECK SHEET.....	14

FIG. 1: PULSE GENERATOR TEST ARRANGEMENT

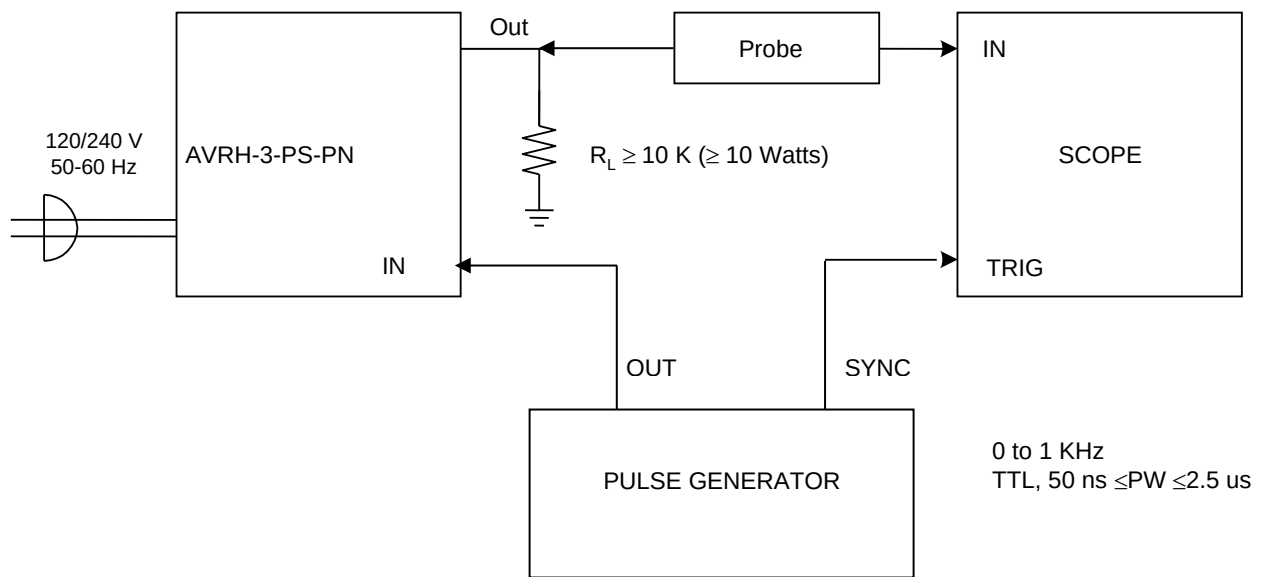

GENERAL OPERATING INSTRUCTIONS

- 1) CAUTION: EXTREME CAUTION SHOULD BE FOLLOWED WHEN USING THIS INSTRUMENT AS IT GENERATES OUTPUT PULSE AMPLITUDES AS HIGH AS 3,000 VOLTS.
- 2) CAUTION: DC potentials as high as 800 Volts and pulse potentials as high as 3000 Volts exist in the interior of the instrument. For this reason it is recommended that the top cover of the unit should not be removed and that the unit should be returned to the factory for servicing when necessary.
- 3) The bandwidth capability of components and instruments used to display the pulse generator output signal (attenuators, cables, connectors, etc.) should exceed 50 MHz. The load impedance should not be less than 1,000 Ohms as this will result in possible damage to the output stages. Also, the coaxial cable between the SHV output connector and the load should not exceed about 0.5 meters (or the rise time will be degraded).
- 4) With the AB mode switch in the A position, the output pulse width is controlled by the front panel pulse width control. To voltage control the output pulse width, set the rear panel switch in the EXT position and apply 0 to +10V to the "A" BNC connector ($R_{IN} \geq 10K$). (Option)
- 5) With the AB mode switch in the B position, the output pulse width is equal to the input trigger pulse width. CAUTION: The input pulse width must not exceed 2.5 us.
- 6) The output pulse amplitude is controlled by means of the front panel ten turn AMP control. To voltage control the output amplitude, set the rear panel switch in the EXT position and apply 0 to +10V to the "A" BNC connector ($R_{IN} \geq 10K$). (option).

CAUTION: To avoid stressing the output stage it is recommended that the output amplitude control be set fully counter clockwise before applying prime power to the instrument.

- 7) The output pulse polarity is controlled by the front panel two-position polarity switch. CAUTION: Before changing polarity, the amplitude should be reduced to zero ($\leq 300V$). If the amplitude is not reduced to near zero, the polarity reversal will not occur.
- 8) CAUTION: The output stage is protected against overload condition by a 1.0 A slow blow fuse on the main frame back panel. However, the output

switching elements may fail if the unit is triggered at a PRF exceeding 1 kHz or at duty cycles resulting in an average output power in excess of 25 Watts. Heating and subsequent likely failure of the output stage is reduced if the following action is taken where possible:

- a) PRF is kept to a minimum, i.e. operate in a low PRF range when possible rather than in a high PRF range.
 - b) Keep the output PW to a minimum.
- 9) OVERLOAD INDICATOR. AVRH units with a serial number higher than 5600 are protected by an automatic overload protective circuit, which controls the front panel overload light. If the unit is overloaded (by operating at an exceedingly high duty cycle or by operating into a short circuit), the protective circuit will turn the output of the instrument OFF and turn the indicator light ON. The light will stay ON (i.e. output OFF) for about 5 seconds after which the instrument will attempt to turn ON (i.e. light OFF) for about 1 second. If the overload condition persists, the instrument will turn OFF again (i.e. light ON) for another 5 seconds. If the overload condition has been removed, the instrument will turn on and resume normal operation. Overload conditions may be removed by:
- 1) Reducing PRF (i.e. switch to a lower range)
 - 2) Reducing pulse width (i.e. switch to a lower range)
 - 3) Removing output load short circuit (if any)
- 10) Note that when the amplitude or PRF or PW are increased, the output stage of the unit will emit an audible hum. This noise is normal and is due to the step up transformer in the output stage.
- 11) The unit can be converted from 120 to 240V, 50-60 Hz operation by adjusting the voltage selector card in the rear panel fused voltage selector cable connector assembly.
- 12) For further assistance:
- Tel: 613-226-5772
Fax: 613-226-2802
Email: info@avtechpulse.com

FIG. 2: FRONT PANEL CONTROLS

FRONT PANEL CONTROLS

- (1) ON-OFF Switch. Applies basic prime power to all stages.
- (2) OUT Connector. SHV connector provides output to a high impedance load ($R_L \geq 10 \text{ K}$). Panel connector will mate to King 1705-2 connector (for RG58C cable).
- (3) POLARITY. The output pulse polarity is controlled by this two-position switch. CAUTION: Before changing polarity, the amplitude should be reduced to zero ($\leq 300 \text{ Volts}$). The polarity reversal will not occur if the amplitude is not reduced.
- (4) AMP Control. A ten turn control which varies the output pulse amplitude from 0 to 3000 V (to $R_L \geq 10 \text{ K}$).
- (5) TRIG Input. The external trigger signal is applied at this input.
- (6) PW Control. When the MODE A-B switch is in the A position, this control varies the output pulse width from 200 ns to 2.5 us.
- (7) AB MODE. When switch is in the A position output pulse width is controlled by PW control (6) while if switch is in the B position, the output pulse width equals the input trigger pulse width. CAUTION: The input pulse width must not exceed 2.5 us.
- (8) OVERLOAD INDICATOR. AVRH units with a serial number higher than 5600 are protected by an automatic overload protective circuit which controls the front panel overload light. If the unit is overloaded (by operating at an exceedingly high duty cycle or by operating into a short circuit), the protective circuit will turn the output of the instrument OFF and turn the indicator light ON. The light will stay ON (i.e. output OFF) for about 5 seconds after which the instrument will attempt to turn ON (i.e. light OFF) for about 1 second. If the overload condition persists, the instrument will turn OFF again (i.e. light ON) for another 5 seconds. If the overload condition has been removed, the instrument will turn on and resume normal operation. Overload conditions may be removed by:
 - 1) Reducing PRF (i.e. switch to a lower range).
 - 2) Reducing pulse width (i.e. switch to a lower range).
 - 3) Removing output load short circuit (if any).

FIG. 3: BACK PANEL CONTROLS

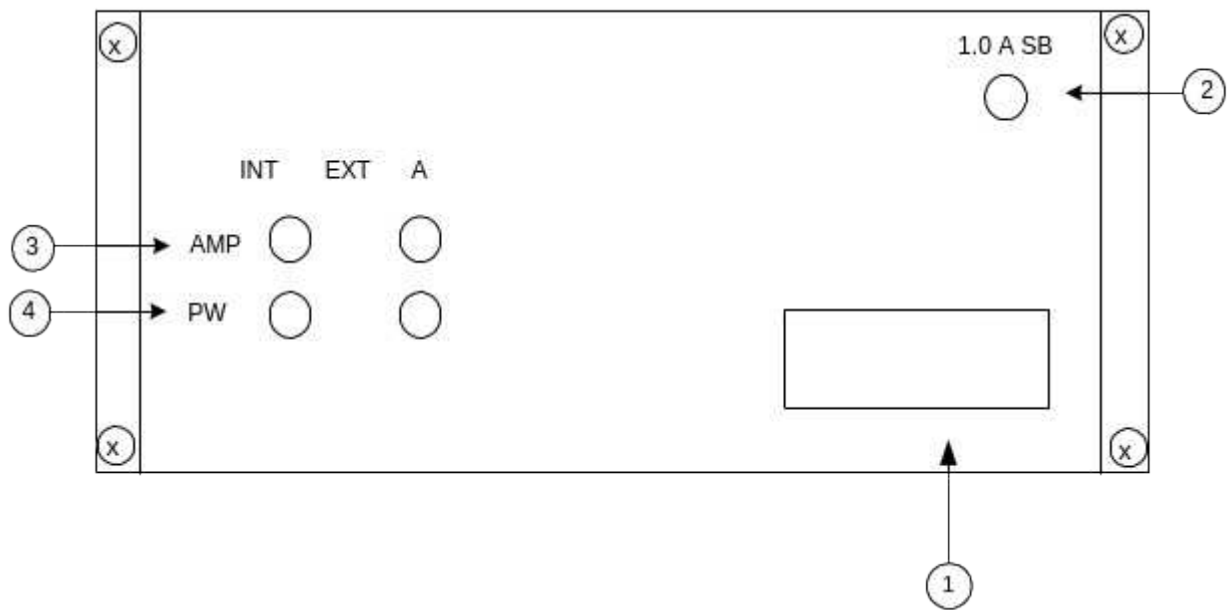

BACK PANEL CONTROLS

- (1) FUSED CONNECTOR, VOLTAGE SELECTOR. The detachable power cord is connected at this point. In addition, the removable cord is adjusted to select the desired input operating voltage. The unit also contains the main power fuse.

For AC line voltages of 110-120V, the power selector card should be installed so that the "120" marking is visible from the rear of the instrument.

For AC line voltages of 220-240V, the power selector card should be installed so that the "240" marking is visible from the rear of the instrument.

If it is not set for the proper voltage, remove the fuse and then grasp the card with a pair of pliers and remove it. Rotate horizontally through 180 degrees. Reinstall the card and the correct fuse.

In the 120V setting, a 1.0A slow blow fuse is required. In the 240V setting, a 0.5A slow blow fuse is required.

- (2) 1.0A SB. Fuse which protects the output stage if the output duty cycle rating is exceeded.
- (3) AMP. To voltage control the output amplitude, set this switch in the EXT position and apply 0 to +10V to the "A" BNC connector ($R_{IN} > 10K$). (option).
- (4) PW. To voltage control the output pulse width, set this switch in the EXT position and apply 0 to +10V to the "A" BNC connector ($R_{IN} > 10K$). (option).

TOP COVER REMOVAL AND RACK MOUNTING

- 1) The interior of the instrument may be accessed by removing the four Phillips screws on the top panel. With the four screws removed, the top cover may be slid back (and off).
- 2) The -R5 rack mount kit may be installed after first removing the one Phillips screw on the side panel adjacent to the front handle.

SYSTEM DESCRIPTION AND REPAIR PROCEDURE

The AVRH-3-PS generates a 3,000 Volt pulse by first generating a 750 Volt pulse (of the desired width). This 750 Volt pulse is then supplied to a x4 transformer which increases the output amplitude to 3,000 Volts (to $R_L > 10K$ Ohms). DC potentials as high as 800 Volts are employed in the generation of the 750 Volt pulse so extreme caution must be employed when repairing this instrument. It is therefore highly recommended that the unit be returned to AVTECH for all repairs beyond the replacement of the 1.0 Amp line fuse or the 1.0 Amp SB rear panel fuse.

PERFORMANCE CHECK SHEET