



# AVTECH ELECTROSYSTEMS LTD.

NANOSECOND WAVEFORM ELECTRONICS  
SINCE 1975

□ P.O. BOX 265  
OGDENSBURG, NY  
U.S.A. 13669-0265

TEL: 888-670-8729 (USA & Canada) or +1-613-686-6675 (Intl)  
FAX: 800-561-1970 (USA & Canada) or +1-613-686-6679 (Intl)

☒ BOX 5120, LCD MERIVALE  
OTTAWA, ONTARIO  
CANADA K2C 3H5

info@avtechpulse.com - <http://www.avtechpulse.com/>

## INSTRUCTIONS

MODEL AVX-S1-P4B

PLUG-IN SOCKET OUTPUT MODULE

SERIAL NUMBER: \_\_\_\_\_

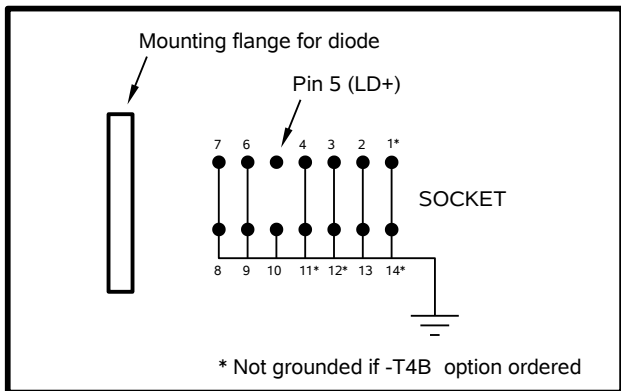

**AVX-S1-P4B OUTPUT MODULE, SOCKET VIEW**

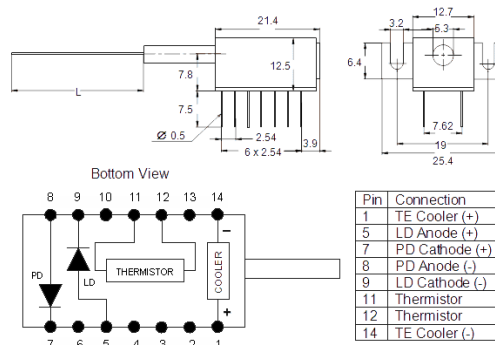

**MATCHING USER-SUPPLIED  
DIODE PACKAGE**

### WARRANTY

Avtech Electrosystems Ltd. warrants products of its manufacture to be free from defects in material and workmanship under conditions of normal use. If, within one year after delivery to the original owner, and after prepaid return by the original owner, this Avtech product is found to be defective, Avtech shall at its option repair or replace said defective item. This warranty does not apply to units which have been disassembled, modified or subjected to conditions exceeding the applicable specifications or ratings. This warranty is the extent of the obligation assumed by Avtech with respect to this product and no other warranty or guarantee is either expressed or implied.

### TECHNICAL SUPPORT

Phone: 888-670-8729 (USA & Canada) or +1-613-686-6675 (International)

Fax: 800-561-1970 (USA & Canada) or +1-613-686-6679 (International)

E-mail: [info@avtechpulse.com](mailto:info@avtechpulse.com)

World Wide Web: <http://www.avtechpulse.com>

## TABLE OF CONTENTS

<b>WARRANTY.....</b>	<b>2</b>
<b>TECHNICAL SUPPORT.....</b>	<b>2</b>
<b>TABLE OF CONTENTS.....</b>	<b>3</b>
<b>INTRODUCTION.....</b>	<b>4</b>
<b>AVAILABLE OPTIONS.....</b>	<b>5</b>
<b>SPECIFICATIONS.....</b>	<b>6</b>
<b>GENERAL INFORMATION.....</b>	<b>7</b>
<b>NORMAL TEST ARRANGEMENT.....</b>	<b>7</b>
<b>THERMAL CONTROL (-T4B UNITS).....</b>	<b>8</b>
<b>SIGNAL CONNECTORS ON THE OUTPUT MODULE.....</b>	<b>8</b>
<b>AMPLITUDE CONTROL.....</b>	<b>8</b>
<b>-INV OPTION.....</b>	<b>9</b>
<b>COMPATIBLE PULSE GENERATORS.....</b>	<b>9</b>
<b>PERFORMANCE CHECKSHEET.....</b>	<b>10</b>

Manual Reference: /files/server1/officefiles/instructword/avx-s/AVX-S1-P4B with -T4B-INV optional,ed3.odt.

Last modified February 29, 2024.

Copyright © 2024 Avtech Electrosystems Ltd, All Rights Reserved.

## INTRODUCTION

The AVX-S series of bias insertion units is designed to combine a pulse signal with a DC bias, and supply the resulting signal to a laser diode, which is inserted into a high quality socket included on the mount. The bias insertion module includes the necessary networks to match the laser diode to the pulse source, as well as networks for applying DC bias to the diode.

The AVX-S1-P4B is specifically designed to accommodate DIL-packaged laser diodes with the pinout illustrated below:

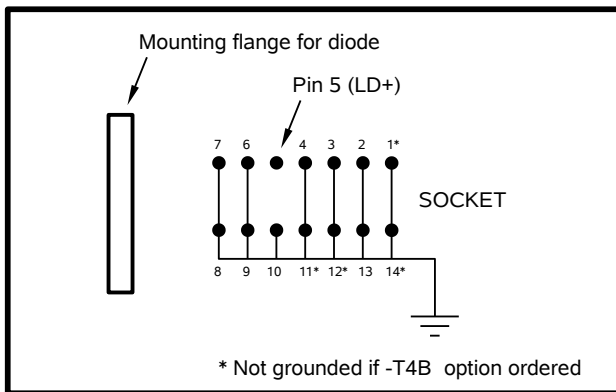

**AVX-S1-P4B OUTPUT MODULE, SOCKET VIEW**

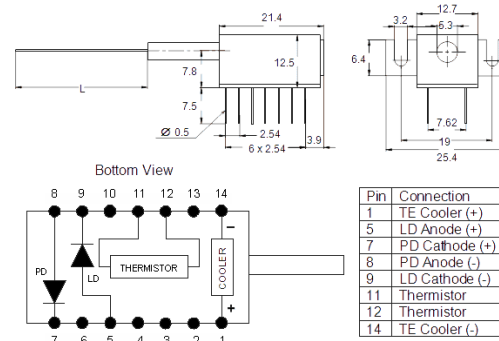

**MATCHING USER-SUPPLIED  
DIODE PACKAGE**

### AVAILABLE OPTIONS

A number of options are available for the AVX-S1-P4B, including:

-T4B option: A male DB-9 connector is provided on the output module, which provides access to the thermal control pins of the DIL-package diode. DB-9 pin 2 connects to diode pin 11 (TH). DB-9 pin 3 connects to diode pin 12 (TH). DB-9 pin 4 connects to diode pin 1 (TEC+). DB-9 pin 5 connects to diode pin 14 (TEC-). The remaining DB-9 pins are unconnected. Pins 2-4 and 6-10 of the diode are grounded. Access to the photodiode, if present, is not provided. This option requires the -P4B option. This option is designed for compatibility with Thorlabs temperature controllers and Qphotonics laser diodes. It may be suitable for others as well.

-INV option: Adds a polarity-inverting transformer to the input of the AVX-S1-P4B.

## SPECIFICATIONS

Model:	AVX-S1-P4B
Peak diode current:	400 mA
Max. input amplitude:	20 Volts
Pulse width:	0.4 <sup>1</sup> - 200 ns
Rise time:	0.2 ns <sup>1</sup>
Pulse PRF range:	DC - 25 MHz
Max. bias current:	100 mA
Max. bias voltage:	50 Volts
Input impedance:	50 Ohms
N (transformer ratio <sup>2,3</sup> ):	+1
$R_S + R_{DIODE}$ :	50 Ohms
IN connector:	SMA female (one)
Other connectors:	MV, MI, MD: SMA (female), DC bias: solder terminal
Diode socket:	Provides a socket pinout suitable for use with certain Qphotonics DIL laser diodes (and others). The signal will be applied to pin 5, the laser anode. All other pins (1-4, 6-14) will normally be grounded. No access is provided to the thermal control pins, unless the -T4B option is ordered. The laser input impedance (dV/dI at lasing) must be between 0 and 5 Ohms.
Dimensions:	H x W x D: 41 mm x 66 mm x 76 mm (1.6" x 2.6" x 3.0")
Material:	Cast aluminum, blue enamel

- 1) Lower pulse widths (to 0.2 ns) and faster rise times (0.1 ns) may be possible for laser diode packages with very low parasitic inductance. The -P0 and -P2 packages generally have very low inductance. The -P1, -P3, and -TO3 packages normally have somewhat higher parasitic inductance.
- 2) The transformer reduces the input voltage by a factor of N (approx) and increases the current by a factor of N (approx). The load resistance ( $R_S + R_{DIODE}$ ) must equal  $50\Omega / N^2$  (approx).
- 3) A polarity inverting option is available. Add the suffix -INV to the model number to specify this option. "N" is a negative number when this option is installed.

## GENERAL INFORMATION

### NORMAL TEST ARRANGEMENT

To fully test the instrument, and for normal operation, the output module must be connected as shown below. The basic functional equivalent circuit of the output module is shown.

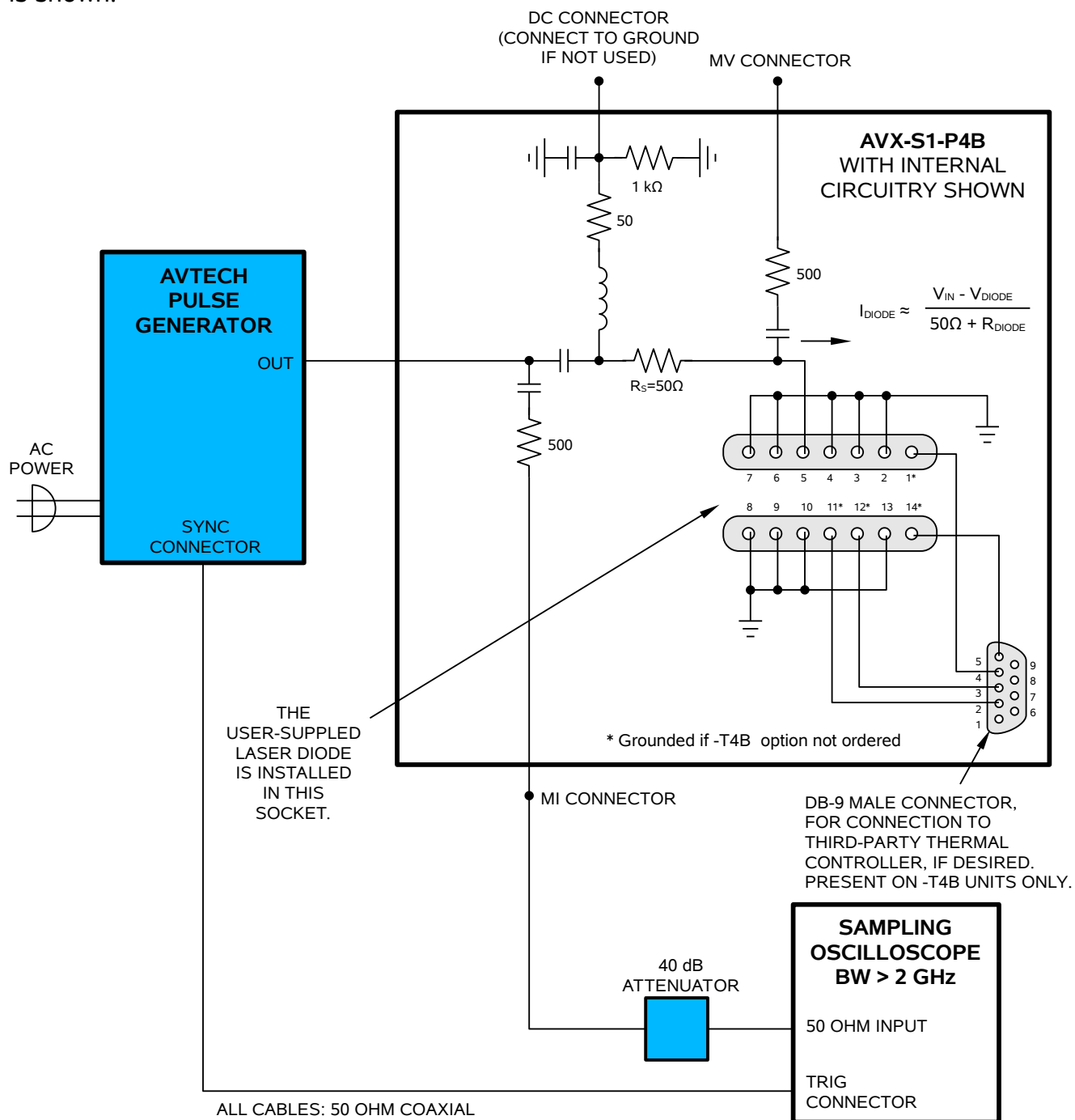

## THERMAL CONTROL (-T4B UNITS)

Models with the “-T4B” option include a DB-9 male connector that will mate to third-party temperature controllers. These third-party controller provide a means of controlling the thermoelectric cooler that is typically present in DIL-packaged laser diodes, if desired. The need for cooling is dependent on the user's application. Cooling is generally recommended by device manufacturers.

## SIGNAL CONNECTORS ON THE OUTPUT MODULE

An oscilloscope may be used to monitor the MI and MV outputs. A forward DC bias may be applied to the laser diode by connecting a DC potential of 0 to +10 Volts to the DC solder terminal. The application of a small forward bias often yields a more ideal diode current waveform (as observed on the MI port).

⚠ Note that the DC port must be shorted to ground if a bias is not applied. Waveform distortions will occur otherwise.

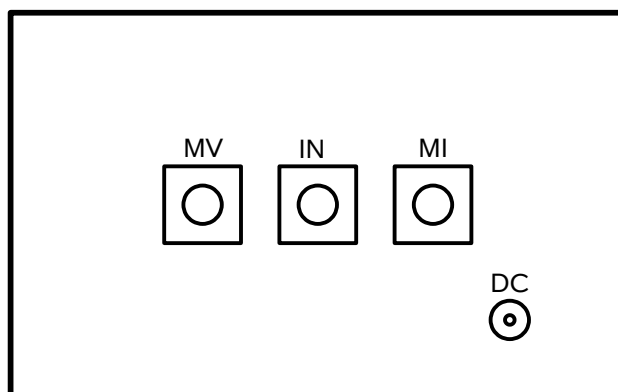

**AVX-S1-P1B OUTPUT MODULE, CONNECTOR VIEW**

## AMPLITUDE CONTROL

The pulse current through the diode load installed in the output module is given by:

$$I_{\text{DIODE}} = (V_{\text{SET}} - V_{\text{DIODE}}) / (50\Omega + R_{\text{DIODE}})$$

where  $V_{\text{SET}}$  is the amplitude setting on the mainframe (between 0 and 13V),  $V_{\text{DIODE}}$  is the forward voltage drop across the diode (typically 2 or 3V), and  $R_{\text{DIODE}}$  is typically negligible (compared to the 50 Ohm series resistance).

Standard AVX-S1-P4B models require a positive pulse ( $V_{\text{SET}} > 0$ ) on the input, in order to forward bias the device anode.



### -INV OPTION

Models with the -INV option have a polarity inverting transformer on the input. This is useful if the user has a pulse generator that generates negative amplitudes only. (The standard AVX-S1-P4B requires a positive pulse for normal operation.)

The amplitude control equation becomes:

$$I_{\text{DIODE}} = (-V_{\text{SET}} - V_{\text{DIODE}}) / (50\Omega + R_{\text{DIODE}})$$

### COMPATIBLE PULSE GENERATORS

The AVX-S1-P4B is designed for use with high-speed Avtech pulse generators, such as those in the AVP, AVPP, AVMP, AVMM, AVMR, AVN, and other families. The AVX-S1-P4B may also be suitable for use with other pulse generators. Contact Avtech ([info@avtechpulse.com](mailto:info@avtechpulse.com)) if you need assistance selecting a pulse generator.

Models in the Avtech AVO-9 series include a pulse generator and an AVX-S series output module in a complete “bundle”. See <http://www.avtechpulse.com/laser/> for details.

PERFORMANCE CHECKSHEET