



AVTECH ELECTROSYSTEMS LTD.

NANOSECOND WAVEFORM ELECTRONICS
SINCE 1975

□ P.O. BOX 265
OGDENSBURG, NY
U.S.A. 13669-0265
TEL: (315) 472-5270
FAX: (613) 226-2802

TEL: 1-800-265-6681
FAX: 1-800-561-1970

e-mail: info@avtechpulse.com
<http://www.avtechpulse.com/>

☒ BOX 5120, LCD MERIVALE
OTTAWA, ONTARIO
CANADA K2C 3H4
TEL: (613) 226-5772
FAX: (613) 226-2802

INSTRUCTIONS

MODEL AVX-S1-MSHD
PLUG-IN SOCKET OUTPUT MODULE
FOR USE WITH THE
AVO-9B-C-N-P1-MSHD

SERIAL NUMBER: _____

AVX-S1-MSHD SOCKET VIEW

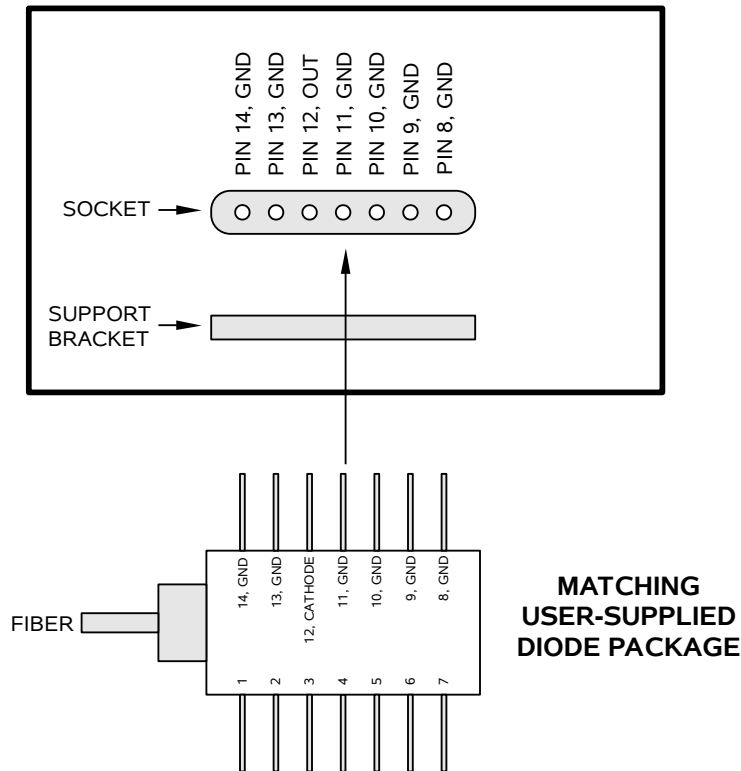

WARRANTY

Avtech Electrosystems Ltd. warrants products of its manufacture to be free from defects in material and workmanship under conditions of normal use. If, within one year after delivery to the original owner, and after prepaid return by the original owner, this Avtech product is found to be defective, Avtech shall at its option repair or replace said defective item. This warranty does not apply to units which have been disassembled, modified or subjected to conditions exceeding the applicable specifications or ratings. This warranty is the extent of the obligation assumed by Avtech with respect to this product and no other warranty or guarantee is either expressed or implied.

TECHNICAL SUPPORT

Phone: 613-226-5772 or 1-800-265-6681

Fax: 613-226-2802 or 1-800-561-1970

E-mail: info@avtechpulse.com

World Wide Web: <http://www.avtechpulse.com>

TABLE OF CONTENTS

WARRANTY.....2
TECHNICAL SUPPORT.....2
TABLE OF CONTENTS.....3
QUOTE NO. 12585.....4
INTRODUCTION.....5
BASIC TEST ARRANGEMENT.....6
INSTALLING THE DIODE.....7
AMPLITUDE CONTROL.....7

Manual Reference: /files/server1/officefiles/instructword/avx-s/AVX-S1-MSHD.sxw.
Last modified February 29, 2024.
Copyright © 2024 Avtech Electrosystems Ltd, All Rights Reserved.

QUOTE NO. 12585

Date: Wed, 18 May 2005 09:52:37 -0400
From: Avtech Sales
To: =?UTF-8?B?5qmY5bed?=
Subject: Re: Inquiry of One more Plug-In Socket Output Module
To: K. Kitsukawa
Meisho Corp.
kitsukawa@78meisho.co.jp

Mr. Kitsukawa,

I believe the correct model number is AVO-9B-C-N-P1-MSHD (not -MSHC). I am pleased to quote as follows:

Quote number: 12585

Model number: AVX-S1-MSHD

Description: Laser Diode Bias Insertion Unit with Socket. Identical to the output module originally supplied with the AVO-9B-C-N-P1-MSHD (S/N 11124). This module is provided with a socket that will accept pins 8-14 of any of the following user-supplied butterfly-packaged laser diodes:

- 1) the Mitsubishi Electric FU-68SDF-V510M01B
- 2) the Fitel FOL15DCWD
- 3) the Fitel FOL15DDBB

A negative pulse will be applied to the diode cathode resistor (pin 12). Pins 8-11 and 13-14 will be grounded.

Price: \$1411 US each, Ex-works, Ottawa, Canada. Before discount.

Quote valid for: 60 days

Estimated delivery: 30 days after receipt of order.

Please call or email me if I can be of further assistance.

Thank you for your interest in our products!

Regards,
Dr. Michael J. Chudobiak
Chief Engineer

INTRODUCTION

The AVX-S1-MSHD output module is designed for use with the Avtech AVO-9B-C-N-P1-MSHD (S/N 11124).

The AVX-S1-MSHD is specifically designed to accommodate the following diodes:

- 1) The Mitsubishi Electric FU-68SDF-V510M01B
- 2) The Fitel FOL15DCWD
- 3) The Fitel FOL15DDBB

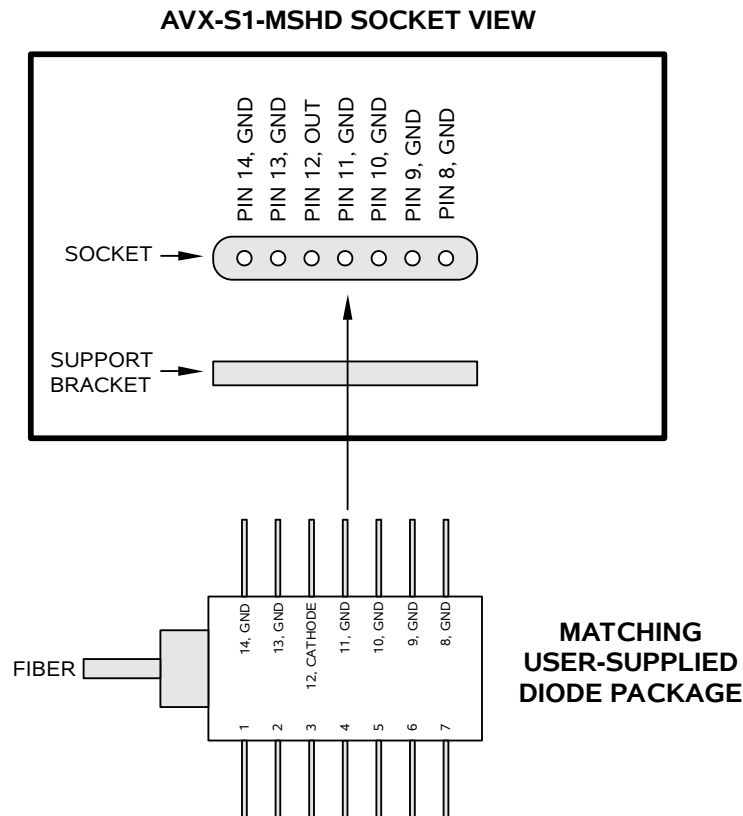

Note: the AVX-S1-MSHD accepts a negative voltage from the mainframe output. The output module drives the cathode of the laser diode; the anode is grounded.

BASIC TEST ARRANGEMENT

To fully test the instrument, and for normal operation, the output module must be connected as shown below:

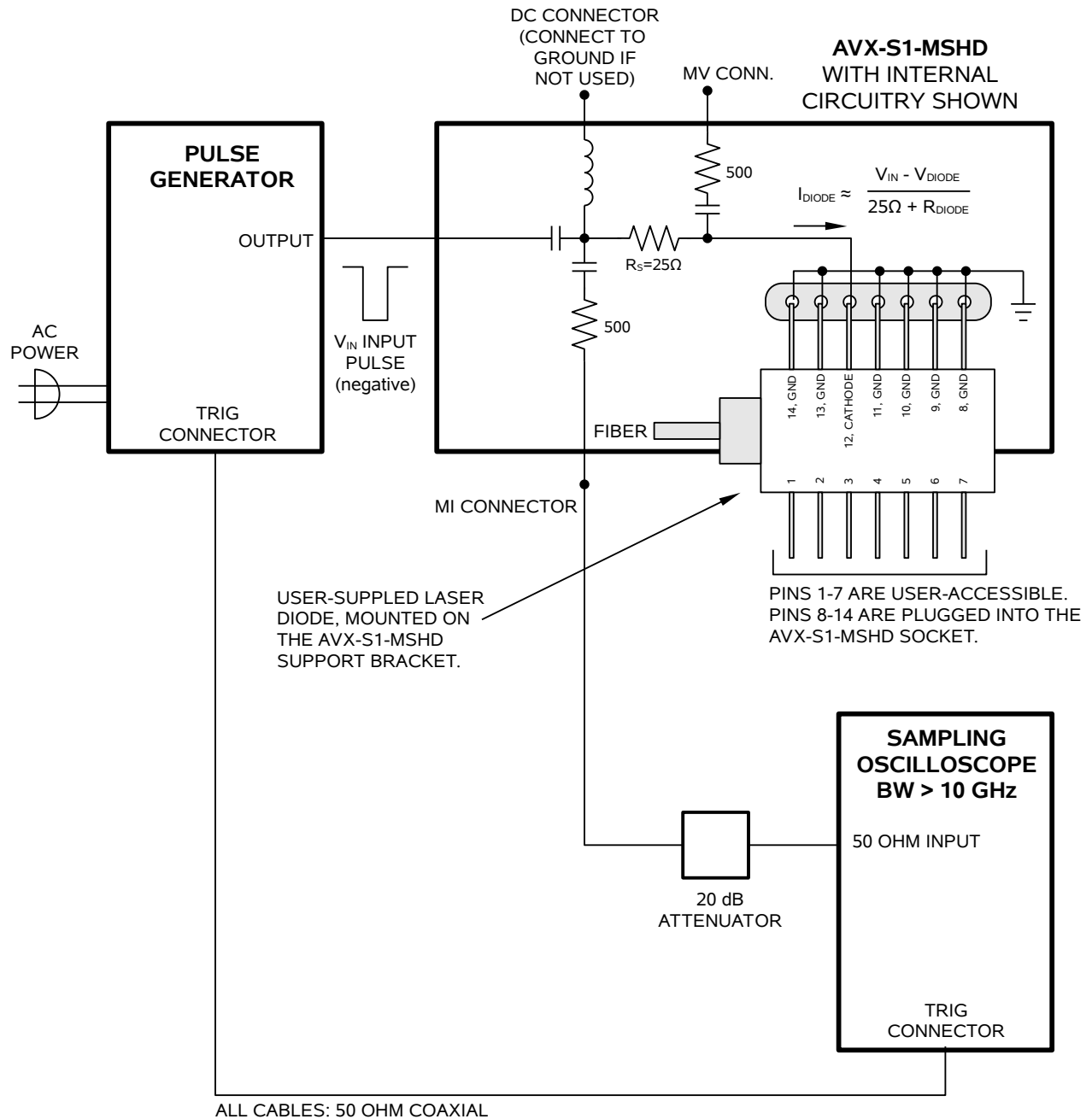

An oscilloscope may be used to monitor the MI and MD outputs, the locations of which are shown in the figure above. A forward DC bias may be applied to the laser diode by connecting a DC potential of 0 to -5 Volts to the DC solder terminal. The application of a small forward bias often yields a more ideal diode current waveform (as observed on the MI port).

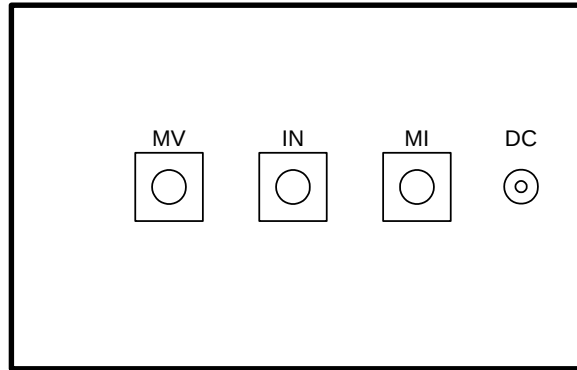

AVX-S1 OUTPUT MODULE, CONNECTOR VIEW

INSTALLING THE DIODE

To install the diode in the output module socket, align the diode so that pins 8-14 are facing the socket, and the mounting flange of the diode is underneath the main body of the diode. Gently and slowly insert the diode into the socket. Insert it far enough that the mounting holes on the diode align with the mounting holes on the support bracket. Secure the diode to the support bracket using four 2-56 screws.

It is recommended that pins 8-14 be trimmed from their normal length to a shorter length of 7 mm. This will make it easier to insert and remove the diode.

AMPLITUDE CONTROL

When using the output module, the pulse current through the diode load is given by:

$$I_{\text{DIODE}} = (V_{\text{SET}} - V_{\text{DIODE}}) / (25\Omega + R_{\text{DIODE}})$$

where V_{SET} is the amplitude setting on the mainframe (between 0 and -18V), V_{DIODE} is the forward voltage drop across the diode (up to -3V), and R_{DIODE} is the resistor internal to the laser diode (typically 20 Ω to 30 Ω). The 25 Ω resistance is built into the AVX-S1-MSHD output module.

For optimal results, the laser diode resistance should be 25 Ω , so that $25\Omega + R_{\text{DIODE}} = 50\Omega$, resulting in a proper transmission line match for the 50 Ω coaxial cabling. However, laser diode resistances in the range of 20 Ω to 30 Ω will provide good results with minimal distortion.

 Diode note: When this instrument is used with the Mitsubishi Electric FU-68SDF-V510M01B, we recommend that a user-supplied 6 dB attenuator be connected between the mainframe and the output module, to avoid exceeding the 150 mA maximum current rating of the diode.