



AVTECH ELECTROSYSTEMS LTD.

NANOSECOND WAVEFORM ELECTRONICS
SINCE 1975

□ P.O. BOX 265
OGDENSBURG, NY
U.S.A. 13669-0265
TEL: (315) 472-5270
FAX: (613) 226-2802

TEL: 1-800-265-6681
FAX: 1-800-561-1970

e-mail: info@avtechpulse.com
<http://www.avtechpulse.com/>

☒ BOX 5120, LCD MERIVALE
OTTAWA, ONTARIO
CANADA K2C 3H4
TEL: (613) 226-5772
FAX: (613) 226-2802

INSTRUCTIONS

MODEL AVX-S1-P1-MEGC

PLUG-IN SOCKET OUTPUT MODULE

SERIAL NUMBER: 11175

AVX-S1-P1-MEGC SOCKET VIEW

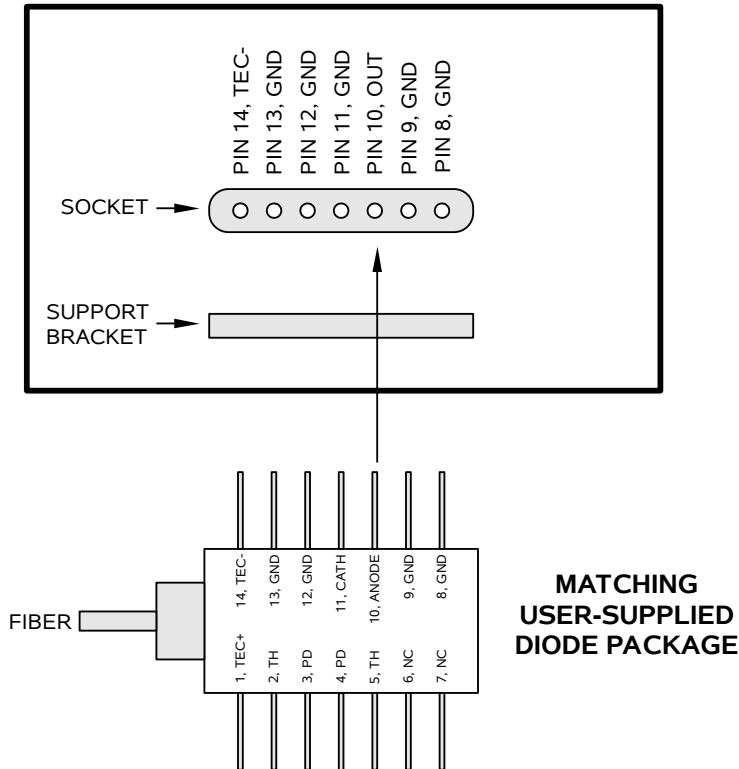

WARRANTY

Avtech Electrosystems Ltd. warrants products of its manufacture to be free from defects in material and workmanship under conditions of normal use. If, within one year after delivery to the original owner, and after prepaid return by the original owner, this Avtech product is found to be defective, Avtech shall at its option repair or replace said defective item. This warranty does not apply to units which have been disassembled, modified or subjected to conditions exceeding the applicable specifications or ratings. This warranty is the extent of the obligation assumed by Avtech with respect to this product and no other warranty or guarantee is either expressed or implied.

TECHNICAL SUPPORT

Phone: 613-226-5772 or 1-800-265-6681

Fax: 613-226-2802 or 1-800-561-1970

E-mail: info@avtechpulse.com

World Wide Web: <http://www.avtechpulse.com>

TABLE OF CONTENTS

WARRANTY.....	2
TECHNICAL SUPPORT.....	2
TABLE OF CONTENTS.....	3
INTRODUCTION.....	4
ORIGINAL QUOTATION.....	5
SPECIFICATIONS.....	7
GENERAL INFORMATION.....	8
BASIC TEST ARRANGEMENT.....	8
INSTALLING THE DIODE.....	9
AMPLITUDE CONTROL.....	9

Manual Reference: /files/server1/officefiles/instructword/avx-s/AVX-S1-P1-MEGC,sn11175.sxw.
Last modified February 29, 2024.
Copyright © 2024 Avtech Electrosystems Ltd, All Rights Reserved.

INTRODUCTION

The AVX-S series of bias insertion units is designed to combine a pulse signal with a DC bias, and supply the resulting signal to a laser diode, which is inserted into a high quality socket included on the mount. The bias insertion module includes the necessary networks to match the laser diode to the pulse source, as well as networks for applying DC bias to the diode.

The AVX-S1-P1-MEGC is specifically designed to accommodate the Lumics “LU1064_fbg_close” butterfly-packaged laser diode with the pinout illustrated below:

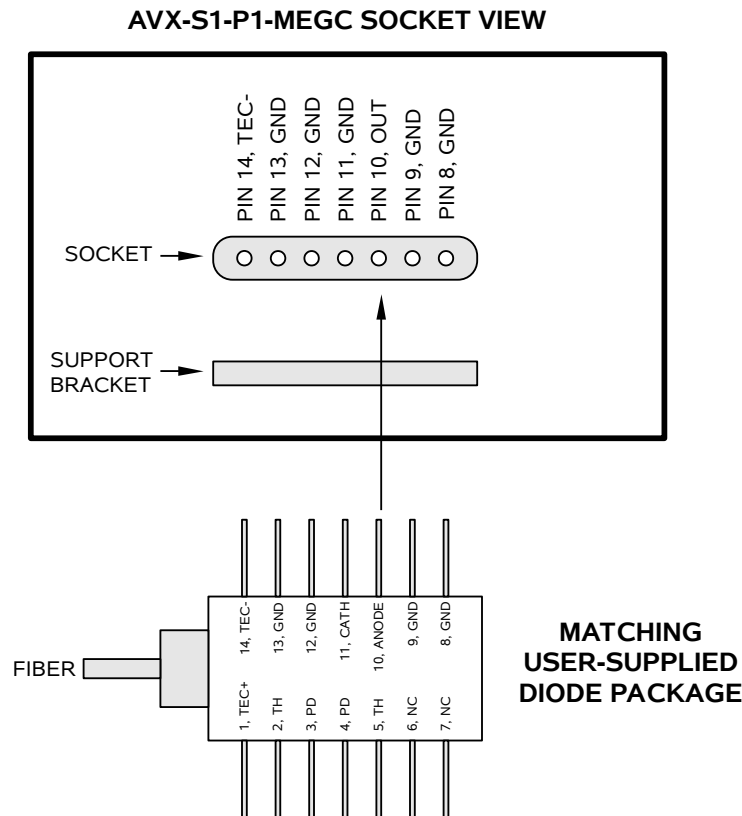

ORIGINAL QUOTATION

Date: Fri, 25 Feb 2005 07:31:43 -0500
 From: Avtech Sales
 Subject: Re: AVO-9 series

XXXXXX,

I am pleased to re-quote as follows (with accessible pin 14):

Quote number: 12481

Model number: AVX-S1-P1-MEGC

Description: Laser Diode Bias Insertion Unit with Socket, intended for use with the AVO-9A-C-P-T03-MEGA mainframe (S/N 11094). The socket will accept pins 8-14 of the Lumics LU1064_fbg_close butterfly-packaged laser diode described in the datasheet that you have supplied. A positive pulse will be applied to the diode anode (pin 10). Pins 8-9 and 11-13 will be grounded. Pin 14 will be made accessible through a solder terminal.

Other: as per the standard AVX-S1, described at
<http://www.avtechpulse.com/laser-bias/avx-s1>

Price: \$XXXXX US each, FOB destination. Valid only for delivery within the United States. This product is not subject to export controls.

Quote valid for: 60 days

Estimated delivery: 30 days after receipt of order.

Please call or email me if I can be of further assistance.

Thank you for your interest in our products!

Regards,
 Dr. Michael J. Chudobiak
 Chief Engineer

--- Avtech Electrosystems Ltd. ----- since 1975 ---

PO Box 265	ph: 1-800-265-6681 or 613-226-5772	Box 5120,
Ogdensburg,	fax: 1-800-561-1970 or 613-226-2802	LCD Merivale
New York	email: info@avtechpulse.com	Ottawa, Ontario
USA 13669-0265	http://www.avtechpulse.com/	Canada K2C 3H4

Nanosecond Waveform Generators
 for general purpose, R&D and OEM applications

Pulse Generators - Laser Diode Drivers - Pulse Amplifiers

Impulse Generators - Current Pulsers - Delay Generators - Splitters
Function Generators - Monocycle Generators - Frequency Dividers + more!

SPECIFICATIONS

Model:	AVX-S1
Peak diode current:	400 mA
Max. input amplitude:	20 Volts
Pulse width (ns):	0.4 - 200
Rise time (ns):	0.2
Pulse PRF range:	DC-100 MHz
Max. bias current:	100 mA
Max. bias voltage:	50 Volts
Input impedance:	50 Ohms
R _s :	50 Ohms
IN connector:	SMA
Monitor connector:	SMA
Bias connector:	Solder pin
Dimensions:	H x W x D: 41 mm x 66 mm x 76 mm (1.6" x 2.6" x 3.0")
Material:	Cast aluminum, blue enamel
Mounting:	Any

GENERAL INFORMATION

BASIC TEST ARRANGEMENT

To fully test the AVX-S1-P1-MEGC, and for normal operation, the output module should be connected as shown below:

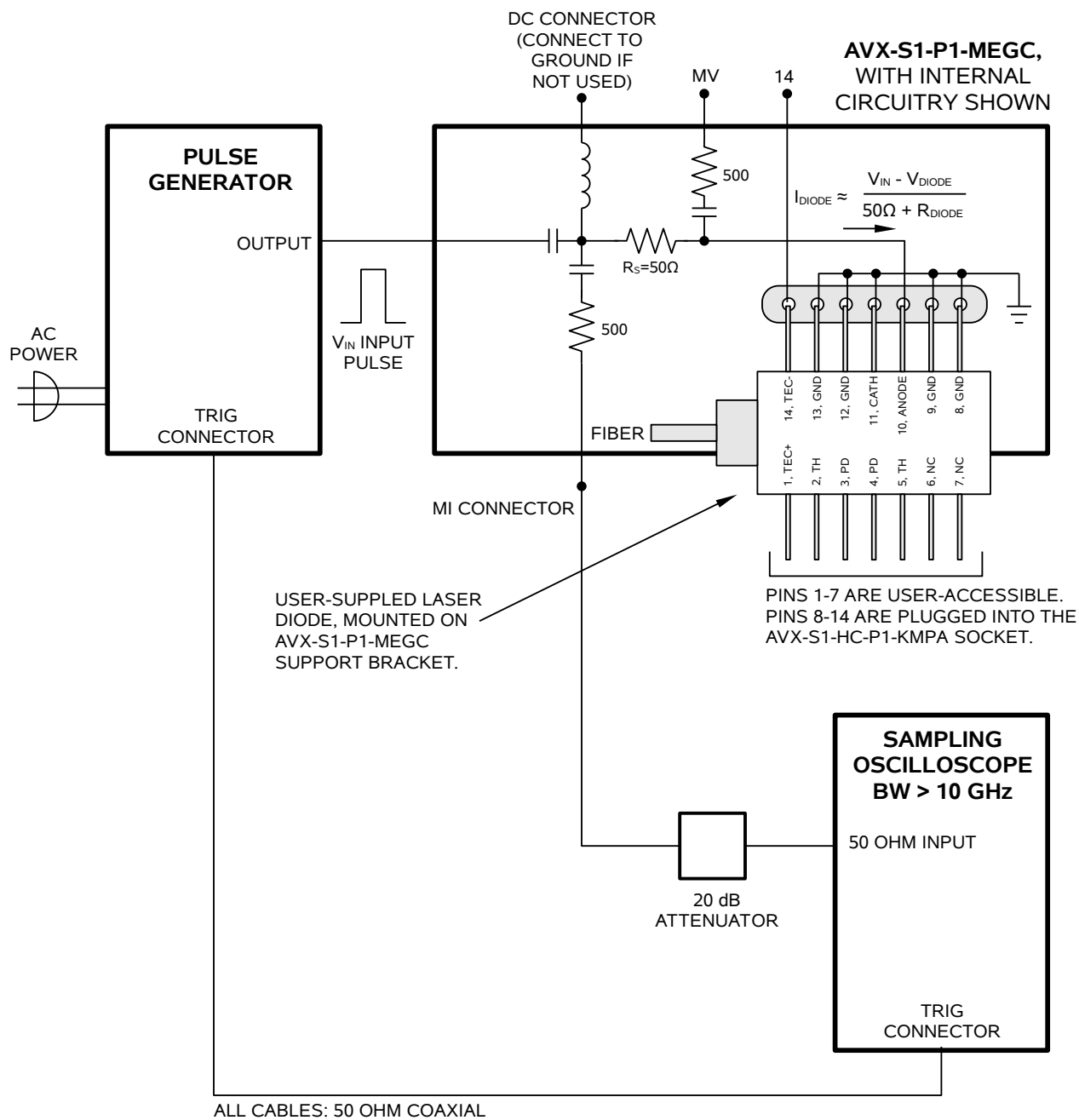

The diode load is inserted into the socket on the output module, as shown above.

An oscilloscope may be used to monitor the MI and MV outputs, the locations of which are shown in the figure above. A forward DC bias may be applied to the laser diode by connecting a DC potential of 0 to 5 Volts to the DC solder terminal. The application of a small forward bias often yields a more ideal diode current waveform (as observed on the MI port). The DC port must be shorted to ground if a bias is not applied.

Access to pin 14 of the diode package is provided through a solder terminal, as shown below. This allows full access to the thermoelectric cooler circuitry (through diode pins 1 and 14).

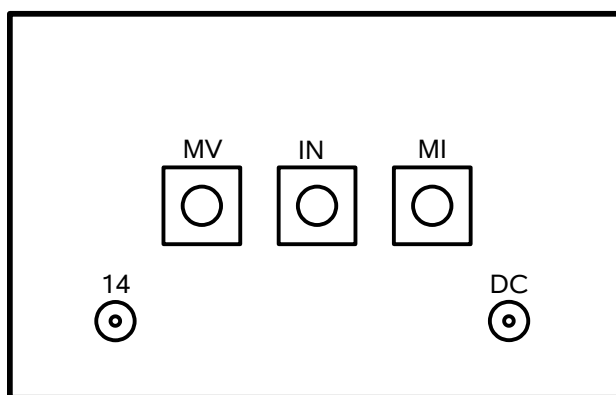

AVX-S1-P1-MEGC OUTPUT MODULE, CONNECTOR VIEW

INSTALLING THE DIODE

To install the diode in the output module socket, align the diode so that pins 8-14 are facing the socket, and the mounting flange of the diode is underneath the main body of the diode. Gently and slowly insert the diode into the socket. Insert it far enough that the mounting holes on the diode align with the mounting holes on the support bracket. Secure the diode to the support bracket using four 2-56 screws.

It may be necessary to first loosen the two 4-40 screws that attach the support bracket to the main body of the AVX-S1-P1-MEGC, to provide optimal alignment of the bracket. Retighten the screws after optimal alignment has been obtained.

It is recommended that pins 8-14 be trimmed from their normal length to a shorter length of 7 mm. This will make it easier to insert and remove the diode.

AMPLITUDE CONTROL

When using the output module, the pulse current through the diode load is given by:

$$I_{\text{DIODE}} \approx (V_{\text{IN}} - V_{\text{DIODE}}) / (50\Omega + R_{\text{DIODE}})$$

where V_{IN} is the amplitude of the input pulse, V_{DIODE} is the forward voltage drop across the diode (typically 2 or 3V), and R_{DIODE} is the series resistance of the diode.