

INSTRUCTIONS

MODEL AVX-S1-P2-MSHB BIAS INSERTION UNIT

S.N.:

WARRANTY

Avtech Electrosystems Ltd. warrants products of its manufacture to be free from defects in material and workmanship under conditions of normal use. If, within one year after delivery to the original owner, and after prepaid return by the original owner, this Avtech product is found to be defective, Avtech shall at its option repair or replace said defective item. This warranty does not apply to units which have been disassembled, modified or subjected to conditions exceeding the applicable specifications or ratings. This warranty is the extent of the obligation assumed by Avtech with respect to this product and no other warranty or guarantee is either expressed or implied.

TECHNICAL SUPPORT

Phone: 613-226-5772 or 1-800-265-6681

Fax: 613-226-2802 or 1-800-561-1970

E-mail: info@avtechpulse.com

World Wide Web: <http://www.avtechpulse.com>

TABLE OF CONTENTS

WARRANTY.....	2
TABLE OF CONTENTS.....	4
FIG. 1: PULSE GENERATOR TEST ARRANGEMENT.....	5
GENERAL OPERATING INSTRUCTIONS.....	6
AVX-S1 FUNCTIONAL EQUIVALENT CIRCUIT.....	7
FU-627SDF-E1M5x PACKAGE DRAWING.....	8
QUOTE No. 11689.....	9

Manual Reference: /fileserver1/officefiles/instructword/avx-s/AVX-S1-P2-MSHB.doc, created September 8, 2003

FIG. 1: PULSE GENERATOR TEST ARRANGEMENT

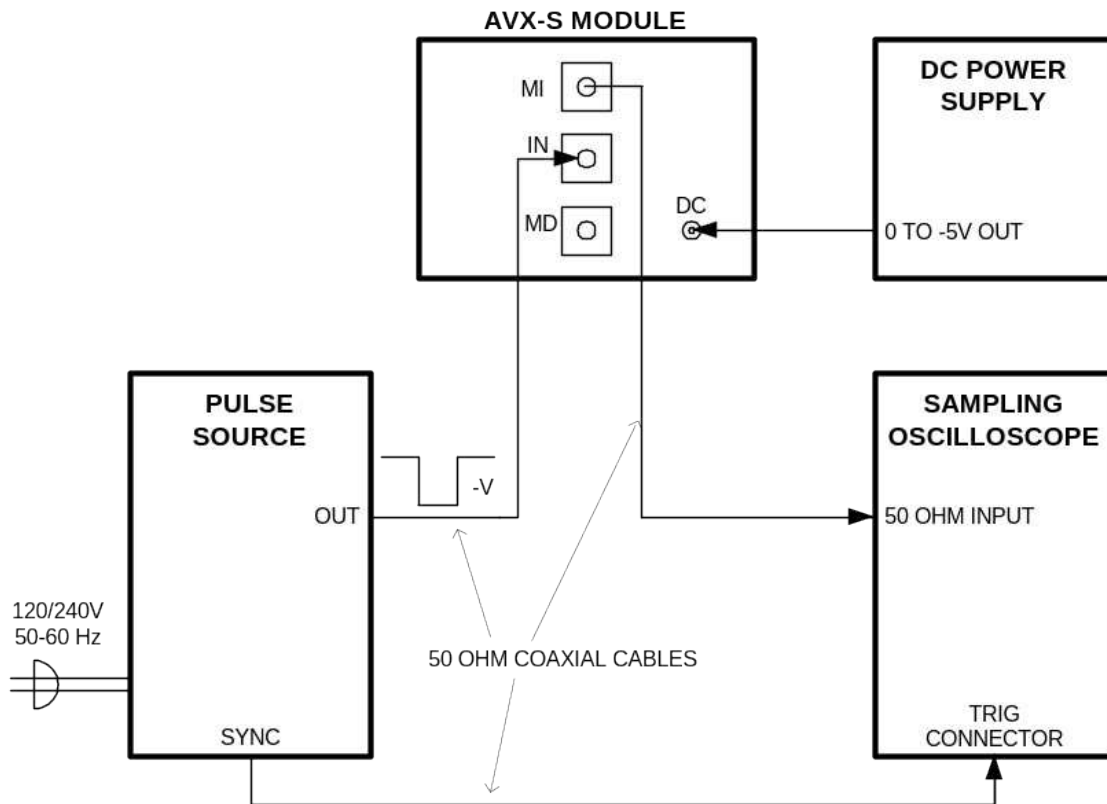

GENERAL OPERATING INSTRUCTIONS

- 1) A general description of the AVX-S1 module is given in the enclosed data sheet.
- 2) The AVX-S1 module should be connected to your pulse source via a 50-Ohm cable (supplied).
- 3) The laser diode plugs directly into the socket on the side of the AVX-S1 module. Take care to gently insert (and remove) the diode and insure that the diode leads do not exceed 0.7 cm in length.

Two 2-56 machine screws are provided to mate with the support flange on the FU-627SDF-FV1 package.

- 4) A forward DC bias may be applied to the laser diode by connecting a DC potential of 0 to -5 Volts to the DC solder terminal. Note that the DC solder terminal must be shorted to ground if the DC bias is not used.
- 5) The diode pulse current may be monitored by connecting the MI and MV output ports to the sampling scope. The output amplitude (V_{MI} and V_{MV} , Volts) and diode current (I_D , Amp) are related as follows:

$$I_D = 0.2 (V_{MI} - V_{MV})$$

AVX-S1 FUNCTIONAL EQUIVALENT CIRCUIT

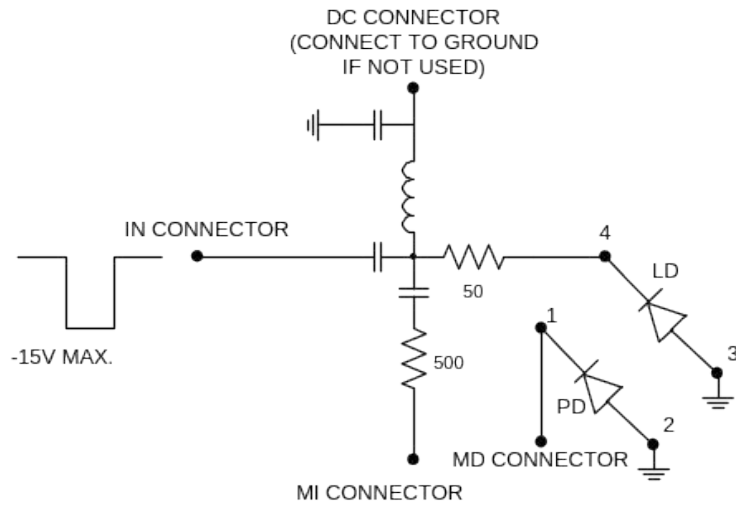

AVX-S1 FUNCTIONAL EQUIVALENT CIRCUIT

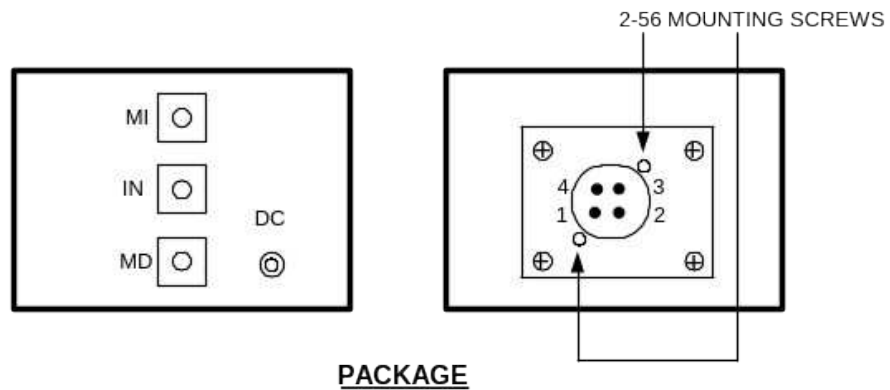

PACKAGE

FU-627SDF-E1M5x PACKAGE DRAWING

QUOTE No. 11689