



**AVTECH ELECTROSYSTEMS LTD.**

NANOSECOND WAVEFORM ELECTRONICS  
SINCE 1975

□ P.O. BOX 265  
OGDENSBURG, NY  
U.S.A. 13669-0265  
TEL: (315) 472-5270  
FAX: (613) 226-2802

TEL: 1-800-265-6681  
FAX: 1-800-561-1970

e-mail: [info@avtechpulse.com](mailto:info@avtechpulse.com)  
<http://www.avtechpulse.com>

□ P.O. BOX 5120 STN. F  
OTTAWA, ONTARIO  
CANADA K2C 3H4  
TEL: (613) 226-5772  
FAX: (613) 226-2802

# OP1B Interface Programming Manual

Firmware Revision 2.41 and later

## WARRANTY

Avtech Electrosystems Ltd. warrants products of its manufacture to be free from defects in material and workmanship under conditions of normal use. If, within one year after delivery to the original owner, and after prepaid return by the original owner, this Avtech product is found to be defective, Avtech shall at its option repair or replace said defective item. This warranty does not apply to units which have been disassembled, modified or subjected to conditions exceeding the applicable specifications or ratings. This warranty is the extent of the obligation assumed by Avtech with respect to this product and no other warranty or guarantee is either expressed or implied.

## Technical Support

Phone: 613-226-5772 or 1-800-265-6681

Fax: 613-226-2802 or 1-800-561-1970

E-mail: [info@avtechpulse.com](mailto:info@avtechpulse.com)

World Wide Web: <http://www.avtechpulse.com>

## Table Of Contents

1. Controlling Instruments with the OP1B Interface.....	1
1.1. Introduction.....	1
1.1.1. The Five Control Modes.....	1
1.1.2. Switching Between Control Modes.....	2
1.2. Local Control.....	4
1.2.1. Introduction.....	4
1.2.2. The Keypad and Other Controls.....	4
1.2.3. Menu Layout.....	4
1.2.4. Trigger Menu.....	6
1.2.5. Delay Menu.....	6
1.2.6. Pulse Width Menu.....	6
1.2.7. Amplitude Menu.....	7
1.2.8. Offset Menu.....	7
1.2.9. Monitor Menu.....	7
1.2.10. Z <sub>OUT</sub> Menu.....	7
1.2.11. Load Menu.....	8
1.2.12. Output Menu.....	8
1.2.13. Invert Menu.....	8
1.2.14. Active Menu.....	8
1.2.15. Logic Level Menu.....	8
1.2.16. Gate Menu.....	9
1.2.17. Control Menu.....	9
1.2.18. Memory Menu.....	9
1.2.19. Setup Menu.....	10
1.3. Introduction to the RS-232 Serial Bus.....	11
1.3.1. Introduction.....	11
1.3.2. RS-232 Communications Settings.....	11
1.3.3. Cable Connections.....	12
1.3.4. Computer Requirements.....	12
1.3.5. Step-By-Step Example For First-Time Use.....	12
1.4. Introduction to the GPIB IEEE-488.2 Bus.....	14
1.4.1. Introduction.....	14
1.4.2. Controller and Cabling Requirements.....	14
1.4.3. Step-By-Step Example For First-Time Use.....	15
1.4.4. IEEE 488.1 Interface Functions.....	16
1.4.5. End-of-String (EOS) Issues.....	16
1.4.6. Other GPIB Notes.....	17
1.4.7. Debugging GPIB Problems.....	17
1.4.8. GPIB Troubleshooting Checklist.....	17
2. Programming Commands.....	1
2.1.1. Command Format.....	1
2.1.2. Numeric Values.....	1
2.1.3. Units.....	2
2.1.4. Query Commands.....	3
2.1.5. Minimum and Maximum Values.....	3
2.1.6. Multi-channel Instruments.....	3
2.1.7. Compound Messages.....	4
2.1.8. Maximum Command Lengths.....	4
2.1.9. Command Execution Order and Coupled Commands.....	5
2.1.10. Execution Speed.....	5
2.2. The DIAGNOSTIC Command Hierarchy.....	6
2.2.1. Tree Structure.....	6
2.2.2. DIAGnostic:AMPLitude:CALibration.....	6

2.2.3. DIAGnostic:MONitor:CALibration.....	6
2.2.4. DIAGnostic:MONitor:STEP.....	7
2.2.5. DIAGnostic:OFFSet:CALibration.....	7
2.3. The DISPLAY Command Hierarchy.....	8
2.3.1. Tree Structure:.....	8
2.3.2. DISPlay:BRIGhtness.....	8
2.4. The MEASURE Command Hierarchy.....	9
2.4.1. Tree Structure:.....	9
2.4.2. MEASure:AMPLitude?.....	9
2.5. The OUTPUT Command Hierarchy.....	10
2.5.1. Tree Structure:.....	10
2.5.2. OUTPut:[STATe] <boolean value>.....	10
2.5.3. OUTPut:[STATe]?.....	10
2.5.4. OUTPut:IMPedance <numeric value>.....	10
2.5.5. OUTPut:IMPedance?.....	10
2.5.6. OUTPut:LOAD 50   10000.....	10
2.5.7. OUTPut:LOAD?.....	10
2.5.8. OUTPut:PROTection:TRIPped?.....	11
2.5.9. OUTPut:TYPE TTL   ECL.....	11
2.5.10. OUTPut:TYPE?.....	11
2.6. The ROUTE Command Hierarchy.....	12
2.6.1. Tree Structure:.....	12
2.6.2. ROUTe:CLOSe.....	12
2.6.3. ROUTe:CLOSe?.....	12
2.7. The SOURCE:CURRENT Command Hierarchy.....	13
2.7.1. Tree Structure:.....	13
2.7.2. [SOURce]:CURRent:[LEVel]:[IMMediate]:[AMPLitude] <numeric value>   EXTeRnal   AMPLify.....	13
2.7.3. [SOURce]:CURRent:[LEVel]:[IMMediate]:[AMPLitude]?.....	13
2.7.4. [SOURce]:CURRent:[LEVel]:[IMMediate]:LOW <numeric value>   EXTeRnal.....	13
2.7.5. [SOURce]:CURRent:[LEVel]:[IMMediate]:LOW?.....	13
2.7.6. [SOURce]:CURRent:PROTection:TRIPped?.....	14
2.8. The SOURCE:FREQUENCY Command Hierarchy.....	15
2.8.1. Tree Structure:.....	15
2.8.2. [SOURce]:FREQUency:[CW   FIXed] <numeric value>.....	15
2.8.3. [SOURce]:FREQUency:[CW   FIXed]?.....	15
2.9. The SOURCE:FUNCTION Command Hierarchy.....	16
2.9.1. Tree Structure:.....	16
2.9.2. [SOURce]:FUNCTion:SHAPE DC   PULSe.....	16
2.9.3. [SOURce]:FUNCTion:SHAPE?.....	16
2.10. The SOURCE:PULSE Command Hierarchy.....	17
2.10.1. Tree Structure:.....	17
2.10.2. [SOURce]:PULSe:PERiod <numeric value>.....	17
2.10.3. [SOURce]:PULSe:PERiod?.....	17
2.10.4. [SOURce]:PULSe:WIDTh <numeric value>   IN.....	17
2.10.5. [SOURce]:PULSe:WIDTh?.....	17
2.10.6. [SOURce]:PULSe:DCYCLe <numeric value>.....	17
2.10.7. [SOURce]:PULSe:DCYCLe?.....	17
2.10.8. [SOURce]:PULSe:HOLD WIDTh   DCYCLe.....	18
2.10.9. [SOURce]:PULSe:HOLD?.....	18
2.10.10. [SOURce]:PULSe:DELay <numeric value>.....	18
2.10.11. [SOURce]:PULSe:DELay?.....	18
2.10.12. [SOURce]:PULSe:DOUBle:[STATe] <boolean value>.....	18
2.10.13. [SOURce]:PULSe:DOUBle:[STATe]?.....	18
2.10.14. [SOURce]:PULSe:DOUBle:DELay <numeric value>.....	18
2.10.15. [SOURce]:PULSe:DOUBle:DELay?.....	18

2.10.16.	[SOURce]:PULSe:POLarity NORMAL   COMPLEMENT   INVERTed.....	19
2.10.17.	[SOURce]:PULSe:POLarity?.....	19
2.10.18.	[SOURce]:PULSe:GATE:TYPE ASYNC   SYNC.....	19
2.10.19.	[SOURce]:PULSe:GATE:TYPE?.....	19
2.10.20.	[SOURce]:PULSe:GATE:LEVEL High LOW.....	19
2.10.21.	[SOURce]:PULSe:GATE:LEVEL?.....	19
2.11.	The SOURCE:VOLTAGE Command Hierarchy.....	20
2.11.1.	Tree Structure:.....	20
2.11.2.	[SOURce]:VOLTage:[LEVEL]:[IMMEDIATE]:[AMPLitude] <numeric value>   EXTERNAL   AMPLify.....	20
2.11.3.	[SOURce]:VOLTage:[LEVEL]:[IMMEDIATE]:[AMPLitude]?.....	20
2.11.4.	[SOURce]:VOLTage:[LEVEL]:[IMMEDIATE]:LOW <numeric value>   EXTERNAL.....	20
2.11.5.	[SOURce]:VOLTage:[LEVEL]:[IMMEDIATE]:LOW?.....	20
2.11.6.	[SOURce]:VOLTage:PROTECTION:TRIPPed?.....	21
2.12.	The STATUS Command Hierarchy.....	22
2.12.1.	Tree Structure:.....	22
2.13.	The SYSTEM Command Hierarchy.....	23
2.13.1.	Tree Structure:.....	23
2.13.2.	SYSTEM:COMMunicate:GPIB:ADDRESS <numeric value>.....	23
2.13.3.	SYSTEM:COMMunicate:GPIB:ADDRESS?.....	23
2.13.4.	SYSTEM:COMMunicate:SERial:CONTRol:RTS ON   IBFull   RFR.....	23
2.13.5.	SYSTEM:COMMunicate:SERial:CONTRol:RTS?.....	23
2.13.6.	SYSTEM:COMMunicate:SERial:[RECeive]:BAUD 1200   2400   4800   9600.....	24
2.13.7.	SYSTEM:COMMunicate:SERial:[RECeive]:BAUD?.....	24
2.13.8.	SYSTEM:COMMunicate:SERial:[RECeive]:BITS 7   8.....	24
2.13.9.	SYSTEM:COMMunicate:SERial:[RECeive]:BITS?.....	24
2.13.10.	SYSTEM:COMMunicate:SERial:[RECeive]:ECHO <boolean value>.....	24
2.13.11.	SYSTEM:COMMunicate:SERial:[RECeive]:ECHO?.....	24
2.13.12.	SYSTEM:COMMunicate:SERial:[RECeive]:PARity:[TYPE] EVEN   ODD   NONE.....	24
2.13.13.	SYSTEM:COMMunicate:SERial:[RECeive]:PARity:[TYPE]?.....	24
2.13.14.	SYSTEM:COMMunicate:SERial:[RECeive]:SBITS 1   2.....	24
2.13.15.	SYSTEM:COMMunicate:SERial:[RECeive]:SBITS?.....	24
2.13.16.	SYSTEM:ERRor:[NEXT]?.....	25
2.13.17.	SYSTEM:ERRor:COUNT?.....	25
2.13.18.	SYSTEM:VERSion?.....	25
2.14.	The TRIGGER Command Hierarchy.....	26
2.14.1.	Tree Structure:.....	26
2.14.2.	TRIGger:SOURce INTERNAL   EXTERNAL   MANUAL   HOLD   IMMEDIATE.....	26
2.14.3.	TRIGger:SOURce?.....	26
2.15.	The IEEE 488.2 Common Command Hierarchy.....	27
2.15.1.	Tree Structure:.....	28
2.15.2.	*CLS.....	28
2.15.3.	*ESE <numeric value>.....	28
2.15.4.	*ESE?.....	28
2.15.5.	*ESR?.....	28
2.15.6.	*IDN?.....	28
2.15.7.	*OPC.....	29
2.15.8.	*OPC?.....	29
2.15.9.	*SAV 0   1   2   3.....	29
2.15.10.	*RCL 0   1   2   3.....	29
2.15.11.	*RST.....	29
2.15.12.	*SRE.....	29
2.15.13.	*SRE?.....	29
2.15.14.	*STB?.....	29
2.15.15.	*TST?.....	29
2.15.16.	*WAI.....	30

2.16. The REMOTE/LOCAL Command Hierarchy.....	31
2.16.1. Tree Structure:.....	31
2.16.2. REMOTE.....	31
2.16.3. LOCAL.....	31
2.17. SCPI Conformance Information.....	32
3. Error Handling and Error Messages.....	1
3.1. Error Handling.....	1
3.2. Error Messages.....	1
3.2.1. No Errors.....	1
3.2.2. Command Errors.....	1
3.2.3. Execution Errors.....	2
3.2.4. Device Dependent Errors.....	2
3.2.5. Query Errors.....	2

# 1. Controlling Instruments with the OP1B Interface

## 1.1. Introduction

This manual describes the "OP1B" computer-control interface that is built into your pulse generator. The other features of your pulse generator are described in a separate manual.

Pulse generators with the OP1B interface can be controlled three ways:

- By the front panel (LOCAL control mode)
- By the GPIB port (GPIB remote control mode)
- By the RS-232 serial port (RS-232 remote control mode)

### 1.1.1. The Five Control Modes

The OP1B has five different control modes. (Four of these are required by the IEEE 488.2 standard, and the fifth is for RS-232 control.)

The display on the instrument's front panel normally indicates which mode the instrument is in, by displaying the phrases "LOCAL CTRL", "LOCAL LOCK", "GPIB CTRL", "GPIB LOCK", or "RS-232 CTRL". The differences between these modes are summarized in the table below:

Mode	Can the pulse settings be changed from the front panel menus?	Can the front panel menu be used to return the instrument to local control?	Can the OP1B receive and execute GPIB commands?	Can the OP1B receive and execute RS-232 commands?
LOCAL CTRL	YES	YES	YES	NO
LOCAL LOCK	YES	NO	YES	NO
GPIB CTRL	NO	YES	YES	NO
GPIB LOCK	NO	NO	YES	NO
RS-232 CTRL	NO	YES	NO	YES

The three main control modes are:

- LOCAL CTRL - The front panel controls are operative. (The GPIB can be used to send commands in this mode.) The instrument is in this mode after power-up.
- GPIB CTRL - In this mode, the instrument is controlled by commands send over the GPIB. The front panel display shows the current instrument settings, but the only menu that can be accessed is the control mode menu, which can be used to force the instrument back into LOCAL CTRL mode.
- RS232 CTRL - In this mode, the instrument is controlled by commands send over the RS-232 port. The front panel display shows the current instrument settings, but the only menu that can be accessed is the control mode menu, which can be used to force the instrument back into LOCAL CTRL mode.

The other two modes are used less frequently:

- GPIB LOCK - In this mode, the instrument is controlled by commands send over the GPIB. None of the front-panel menus can be used. (The front-panel controls are "locked out".)
- LOCAL LOCK - The OP1B switches to this mode when a "Go To Local" command is received in the GPIB LOCK mode. It is very similar to the LOCAL CTRL mode, except that it reverts to the GPIB LOCK mode when it is addressed by the controller.

### **1.1.2. Switching Between Control Modes**

The IEEE 488.1 standard defines the method of switching between the LOCAL CTRL, LOCAL LOCK, GPIB CTRL, and GPIB LOCK modes.

The GPIB controller board (in the user's computer) can switch the instrument from the LOCAL CTRL mode to the GPIB CTRL modes by asserting the GPIB "Remote Enable" (REN) signal and issuing the OP1B's address. This is done automatically by some GPIB software when you wish to send commands to an instrument.

The instrument can be switched back to the LOCAL CTRL mode by using the "Go to local" menu choice on the front panel control menu. The GPIB controller board can also switch the instrument from GPIB CTRL mode to the LOCAL CTRL mode by sending the GPIB "Go To Local" (GTL) signal to the OP1B.

When in the GPIB CTRL mode, the GPIB controller board can also issue the GPIB "Local Lockout" (LLO) signal to the OP1B. This will switch it to the GPIB LOCK mode. This disables of all the front panel controls. The only method of returning to local control in this case is for the GPIB controller board to send the GPIB "Go To Local" (GTL) signal to the OP1B. The instrument will then change to the LOCAL LOCK state.

If the GPIB controller disables the REN (Remote Enable) signal in any mode, the OP1B reverts to LOCAL CTRL mode.

To switch from LOCAL CTRL to RS-232 CTRL, send the message "REMOTE", terminated by a carriage-return character (usually generated by pressing the computer's ENTER key) over the RS-232 connection. The OP1B will respond by sending the message "Ready for command: " over the serial port. The OP1B is then in RS-232 remote control mode. To return to local control, send the command "LOCAL", terminated by a carriage-return character. The instrument can also be switched back to the LOCAL CTRL mode by using the "Go to local" menu choice on the front panel control menu.

Note: The SINGLE PULSE pushbutton is always active, regardless of the lockout state.

The relationship between the different modes is illustrated in the following diagram:



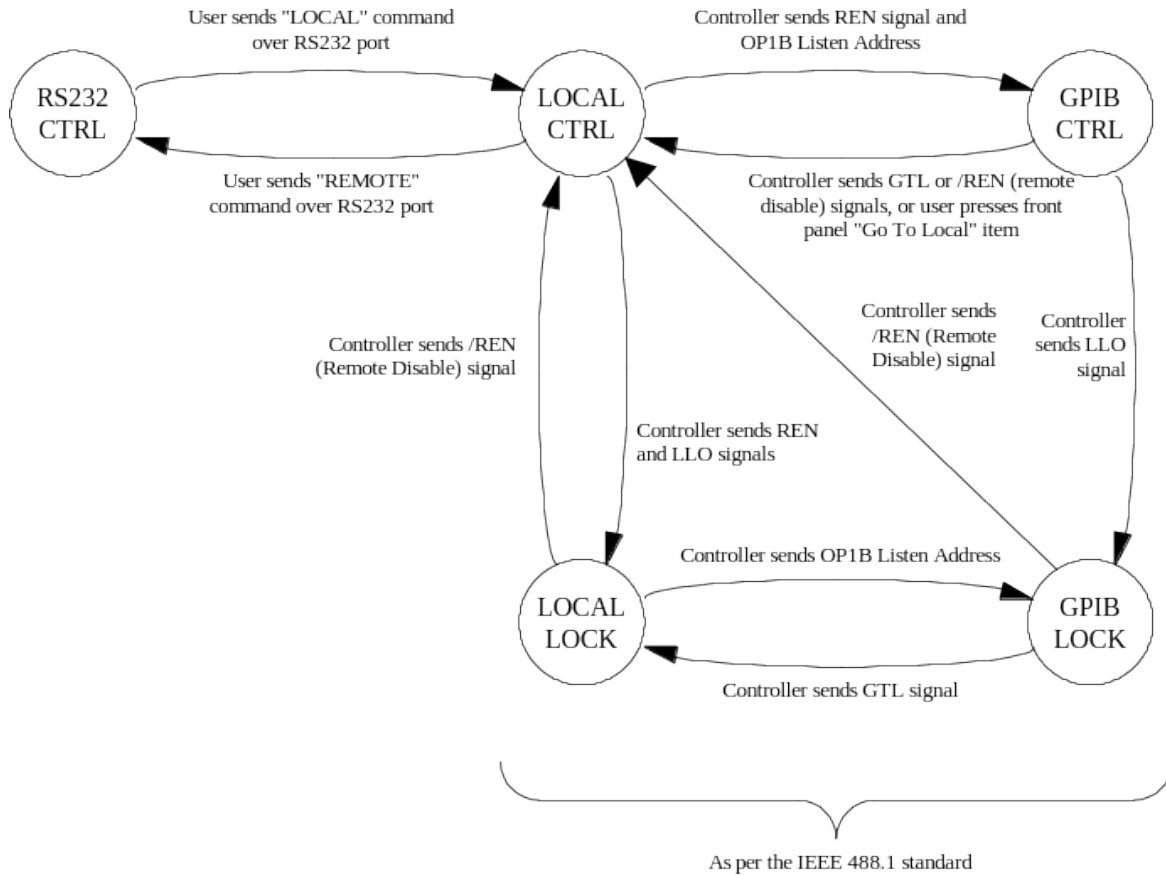

Notes: The text above each arrow specifies the condition that must occur before the transition represented by the arrow occurs.

GTL = "Go To Local" GPIB signal  
 REN = "Remote Enable" GPIB signal  
 LLO = "Local Lockout" GPIB signal  
 /= logical inversion ("NOT")

### Control Mode Switching Diagram

## 1.2. Local Control

### 1.2.1. Introduction

In the local control mode, the instrument is controlled using the front panel keypad and display. When the instrument is first turned on, all key parameters will be displayed, as well as an arrow pointer. This is the Main Menu. To move the arrow pointer, press "MOVE" or turn the "ADJUST" knob. To change one of the parameters, move the arrow pointer to it and press "CHANGE". This will bring up the associated submenu. If a numeric parameter is displayed on the left half of the display, it can be changed by rotating the "ADJUST" knob. If different modes are listed, they can be selected by moving the arrow pointer with the "MOVE" button. When the changes have been made, press the "CHANGE" button to return to the Main Menu.

### 1.2.2. The Keypad and Other Controls

Besides the power switch, there are seven buttons, one knob, and one indicator light on the front panel. Their functions are described below:

Control Name	Function
MOVE	This moves the arrow pointer on the display.
CHANGE	This is used to enter the submenu, or to select the operating mode, pointed to by the arrow pointer.
×10	If one of the adjustable numeric parameters is displayed, this increases the setting by a factor of ten.
÷10	If one of the adjustable numeric parameters is displayed, this decreases the setting by a factor of ten.
+/-	If one of the adjustable numeric parameters is displayed, and this parameter can be both positive or negative, this changes the sign of the parameter.
EXTRA FINE	This changes the step size of the ADJUST knob. In the extra-fine mode, the step size is twenty times finer than in the normal mode. This button switches between the two step sizes.
ADJUST	This large knob adjusts the value of any displayed numeric adjustable values, such as frequency, pulse width, etc. The adjust step size is set by the "EXTRA FINE" button.  When the main menu is displayed, this knob can be used to move the arrow pointer.
OVERLOAD	This warning light comes on if the internal power supplies are supplying more current than they are designed to handle. This light may flash briefly at power-up, but it should not come on at other times. If it does, make sure that the instrument is operating within its allowed amplitude, duty cycle, and load ranges. This indicator is not present on all instruments.

### 1.2.3. Menu Layout

The following chart shows how to access the different menus and submenus. (Note that not all menus and submenus are implemented in all instruments.)

**Menu Layout**

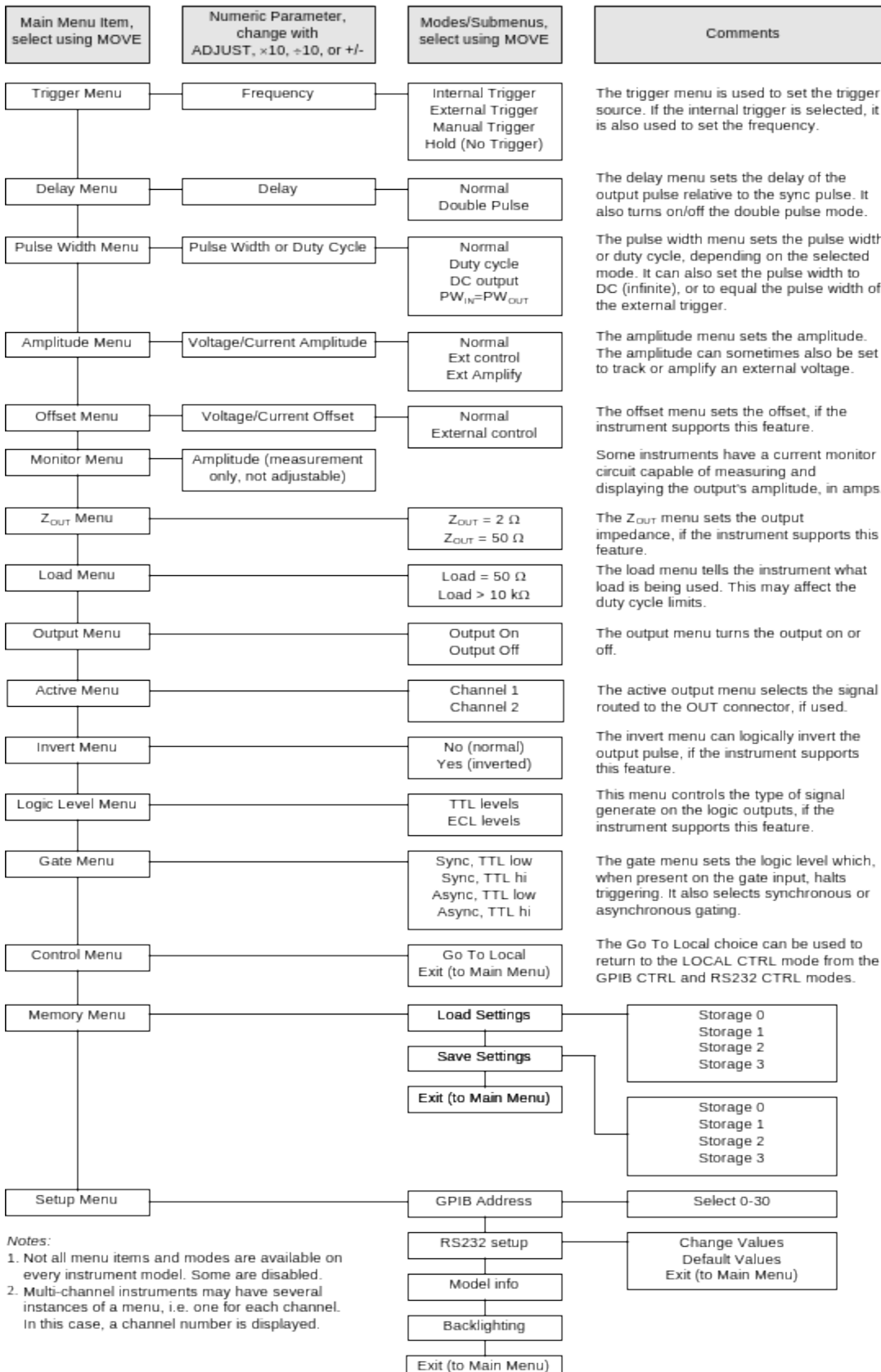

Notes:  
 1. Not all menu items and modes are available on every instrument model. Some are disabled.  
 2. Multi-channel instruments may have several instances of a menu, i.e. one for each channel. In this case, a channel number is displayed.

### 1.2.4. Trigger Menu

This menu is used to select the trigger source. If the instrument is triggering internally, this menu will also display the current frequency setting.

<u>Menu Items</u>	<u>Function</u>
Internal Trigger	This selects the internal clock as the trigger source. In this mode, the menu will also display the current frequency setting. The ADJUST, $\times 10$ , and $\div 10$ controls will change this value.
External Trigger	This selects the TTL-level input on the rear-panel TRIG connector as the trigger source.
Manual Trigger	This selects the single pulse pushbutton on the front panel as the trigger source.
Hold	This halts all triggering.

### 1.2.5. Delay Menu

This menu sets the delay of the output pulse relative to the sync pulse. This delay can generally be positive or negative. (Note that the delay can not exceed 95% of the period).

<u>Menu Items</u>	<u>Function</u>
Normal	In this mode, the output pulse follows the sync pulse by the set delay time. The menu will also display the current delay setting. The ADJUST, $\times 10$ , $\div 10$ , and $\pm$ controls will change this value.
Double Pulse	In this mode, an output pulse occurs simultaneously with the sync pulse, and a second output pulse follows the sync pulse by the set delay time. The menu will also display the current delay setting. The ADJUST, $\times 10$ , and $\div 10$ controls will change this value.

### 1.2.6. Pulse Width Menu

This menu controls the pulse width of the output pulse.

<u>Menu Items</u>	<u>Function</u>
Normal	In this mode, the pulse width is controlled directly, and is held constant when the frequency changes. The menu will display the current pulse width setting. The ADJUST, $\times 10$ , and $\div 10$ controls will change this value.
Duty cycle	In this mode, the duty cycle is controlled directly, and is held constant when the frequency changes. The menu will display the current duty cycle setting. The ADJUST, $\times 10$ , and $\div 10$ controls will change this value. This mode is only applicable when triggering internally.
DC output	This mode sets the output pulse width to DC (i.e., infinite), if the instrument supports this feature.
$PW_{IN}=PW_{OUT}$	This mode is used only when triggering externally. It allows the output pulse width to track the pulse width of the external trigger signal.

### 1.2.7. Amplitude Menu

This menu controls the output amplitude.

<u>Menu Items</u>	<u>Function</u>
Normal	In this mode, the amplitude is controlled directly. The menu will display the current amplitude setting. The ADJUST, $\times 10$ , and $\div 10$ controls will change this value.
Ext Control	If your instrument has a rear-panel "AMP" or "EA" connector, and this mode is activated, the amplitude can be controlled by an external voltage applied to this connector. 0V will set the amplitude to its minimum value, and +10V will set it to its maximum value.
Ext Amplify	In this mode, the output signal is an amplified replica of the signal on one of the input connectors. This feature is not present on all instruments.

### 1.2.8. Offset Menu

This menu controls the output offset, if the instrument supports this feature. The ADJUST,  $\times 10$ , and  $\div 10$  controls will change this value. Certain instruments allow the offset to be controlled by an external DC voltage. For these instruments, these control options are presented:

<u>Menu Items</u>	<u>Function</u>
Normal	In this mode, the offset is controlled directly. The menu will display the current offset setting. The ADJUST, $\times 10$ , and $\div 10$ controls will change this value.
External control	If your instrument has a rear-panel "EO" connector, and this mode is activated, the offset can be controlled by an external DC voltage applied to this connector. 0V will set the offset to its minimum value, and +10V will set it to its maximum value.

### 1.2.9. Monitor Menu

Some instruments have a current monitor circuit capable of measuring and displaying the output's amplitude, in amps. If this feature is present, the monitor menu will display the measured current amplitude of the most recent output pulse. This is a measurement only, and is not adjustable by the user.

### 1.2.10. Z<sub>OUT</sub> Menu

This menu controls the output impedance of the main output, if the instrument supports this feature.

<u>Menu Items</u>	<u>Function</u>
2 $\Omega$	In this mode, the output impedance is low (nominally 2 $\Omega$ ).
50 $\Omega$	In this mode, the output impedance is nominally 50 $\Omega$ . This is useful for backmatching the output into a transmission line. If the output is terminated into a 50 $\Omega$ load, the output voltage will be half of the set value, due to the voltage divider effect between the output resistance and the load.

**1.2.11. Load Menu**

This menu, if present, should be set to the value of the load connected to the main output. This may affect the duty cycle limits. (Some instruments can operate at high duty cycles for higher load impedances.)

<u>Menu Items</u>	<u>Function</u>
Load = 50 $\Omega$	Use this when using a 50 $\Omega$ load.
Load > 10 k $\Omega$	Use this when using a high impedance load.

**1.2.12. Output Menu**

This menu turns the output on or off.

<u>Menu Items</u>	<u>Function</u>
Output on	In this mode, the output is disabled (set to its minimum amplitude and offset, regardless of the amplitude and offset settings.)
Output off	In this mode, the output is enabled and operates normally.

**1.2.13. Invert Menu**

This menu can be used to logically invert the output pulse, if the instrument supports this feature.

<u>Menu Items</u>	<u>Function</u>
No (normal)	In this mode, the output high and low levels are swapped, to logically invert the output pulse.
Yes (inverted)	In this mode, the output pulse is non-inverted.

**1.2.14. Active Menu**

Some instruments have several separate internal channels, which are routed to a common output connector. This menu selects which signal is routed to the output connector, if the instrument supports this feature.

<u>Menu Items</u>	<u>Function</u>
Channel 1	Channel 1 is routed to the output connector.
Channel 2	Channel 2 is routed to the output connector.

**1.2.15. Logic Level Menu**

This menu can be used to control the type of signal present on the auxiliary logic outputs, if the instrument has this feature.

<u>Menu Items</u>	<u>Function</u>
TTL levels	In this mode, the logic outputs swing between 0 and +5V, approximately.
ECL levels	In this mode, the logic outputs swing between -1.6V and -0.8V.

**1.2.16. Gate Menu**

This menu controls the functioning of the rear-panel, TTL-level GATE input. The GATE input can be used to start and stop the instrument from triggering. This menu determines which TTL logic level halts triggering, and whether the gating is synchronous or asynchronous. If the gating is asynchronous, the output waveform will stop almost immediately when the gate is asserted. Output pulses may be truncated. If the gating is synchronous, triggering stops only after the current pulse is completed. No truncation occurs.

Multi-channel instruments have synchronous gating only. Asynchronous gating is not used.

<u>Menu Items</u>	<u>Function</u>
Sync, TTL low	The selects synchronous gating. Triggering will stop if the GATE input is TTL low (0V).
Sync, TTL hi	The selects synchronous gating. Triggering will stop if the GATE input is TTL high (+3V to +5V).
Async, TTL low	The selects asynchronous gating. Triggering will stop if the GATE input is TTL low (0V).
Async, TTL hi	The selects asynchronous gating. Triggering will stop if the GATE input is TTL high (+3V to +5V).

**1.2.17. Control Menu**

When the main menu is displayed, this main menu item displays the current control mode - LOCAL CTRL, LOCAL LOCK, GPIB CTRL, GPIB LOCK, or RS232 CTRL. In all modes except GPIB LOCK, two choices are offered when the submenu is accessed:

<u>Menu Items</u>	<u>Function</u>
Go To Local	In all modes except GPIB LOCK and LOCAL LOCK, this can be used to return to the LOCAL CTRL mode.
Exit	This returns to the main menu.

**1.2.18. Memory Menu**

The OP1B interface can store and recall up to four "snapshots" of all current instrument settings (except the GPIB and RS-232 communication settings) to and from non-volatile memory. The "Save Settings" submenu can be used to store current instrument settings to memory locations 0, 1, 2, or 3. Similarly, the "Load Settings" submenu can be used to recall stored instrument settings from memory locations 0, 1, 2, or 3. If you do not wish to store or load settings, select the "exit" item.

### 1.2.19. Setup Menu

This menu controls the communications setup for the OP1B.

<u>Menu Items</u>	<u>Function</u>
GPIB address	This submenu can be used to change the GPIB address setting. Changes in the GPIB address are implemented immediately.
RS232 setup	This submenu can be used to change the RS232 serial port settings. It can also be used to load a default set of values for the RS232 settings. The default settings are: 1200 bps, 8 data bits, no parity, 1 stop bit, hardware (RTS/CTS) handshaking on, and echo on.
Model info	This displays the instrument's manufacturer, model name, serial number and firmware (software) revision number.
Backlighting	Most Avtech instruments allow the LCD backlight to be turned on and off. This selection toggles the backlighting on or off. The backlight is normally on at start-up. The backlight can be turned off to reduce power consumption. Doing so will save approximately 5 Watts of power.
Exit	This returns to the main menu.



## 1.3. Introduction to the RS-232 Serial Bus

### 1.3.1. Introduction

Most personal computers have at least one RS-232 serial port. This can be used to control pulse generators with the OP1B interface. The RS-232 port allows a single, point-to-point connection between the computer and the OP1B. That is, the computer port can only be attached to one instrument at a time. This connection scheme is illustrated below:

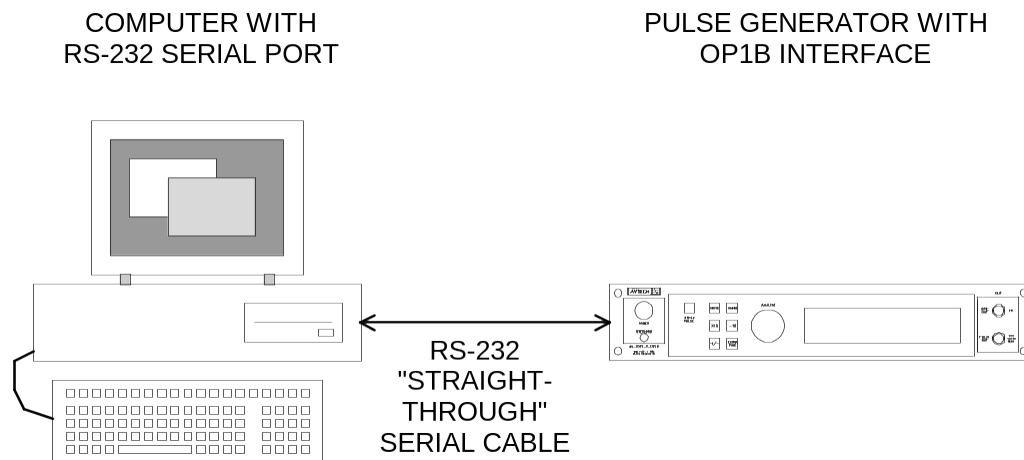

The computer is connected with a RS-232 "straight-through" cable. This cable is available at most computer stores, and it is the same type of cable that is generally used to connect a PC to an external modem. Beware that newer PCs generally have 9-pin male RS-232 connectors, whereas older computers generally have 25-pin male RS-232 connectors. The actual cable wiring connections are described in the "Cable Connections" section.

The RS-232 port can be used to communicate to the OP1B interface at speeds of 1200, 2400, 4800, or 9600 bits per second.

### 1.3.2. RS-232 Communications Settings

The RS-232 serial port has numerous settings associated with it. These must be set to the appropriate values on both the computer (in your terminal software) and the pulse generator in order for the two to communicate properly. On the pulse generator, these settings can be adjusted locally from the front panel, or by using the SYSTem:COMMunicate:SERial family of remote commands. These settings are:

1. **Baud rate.** This is the communication speed settings. The OP1B can communicate at 1200, 2400, 4800, or 9600 bits per second (also called baud).
2. **Data bits.** This must be set to 7 or 8.
3. **Parity.** This can be "even", "odd", or "none".
4. **Stop Bits.** This must be set to 1 or 2.
5. **Handshaking.** The OP1B can either use hardware handshaking (also called RTS/CTS handshaking) or no handshaking to synchronize data transfer. Hardware handshaking is more reliable than no handshaking, since it ensures that the input buffer will not overflow. (The OP1B RS-232 input buffer is 512 bytes long.)
6. **Echoing.** The OP1B can echo back data sent from the computer, if desired. This setting can affect what is displayed on the computer screen. For instance, if the OP1B does not echo

back what is sent from the computer, the user may not see the characters that he or she types into the computer, depending on the computer settings.

One of the front-panel submenu commands allows the user to set the RS232 parameters to their default settings. These are: 1200 bps, 8 data bits, no parity, 1 stop bit, hardware handshaking on, and echo on.

### 1.3.3. Cable Connections

For computers with a 25-pin RS-232 connector, a "straight-through" cable is wired as shown below:

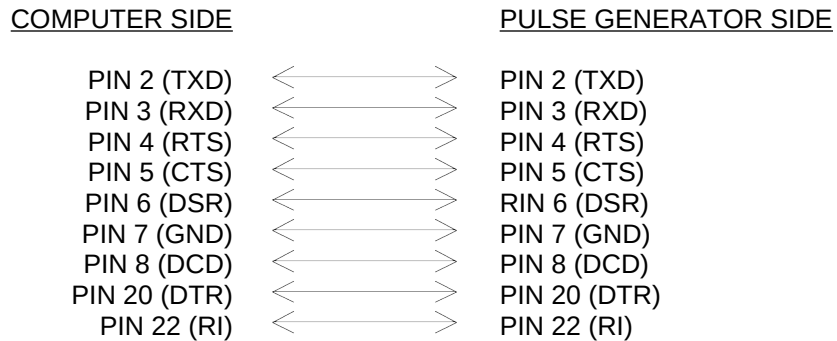

For computers with a 9-pin RS-232 connector, a "straight-through" cable is wired as shown below:

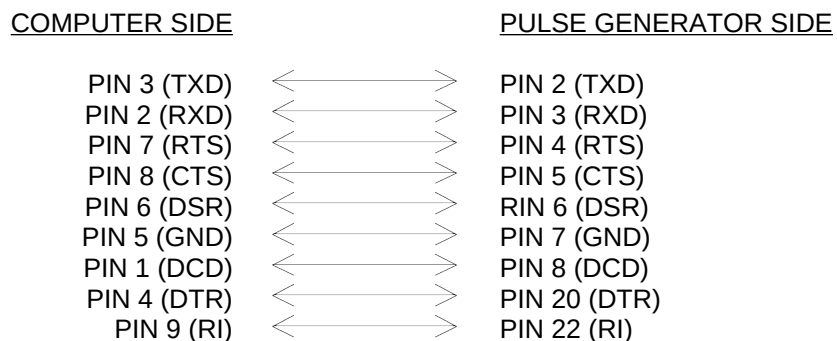

### 1.3.4. Computer Requirements

As noted above, most computers have an RS-232 port built-in. Most modern computers also have a basic serial-port terminal software package included. For instance, Windows 3.1 has the "Terminal" accessory, and Windows 95 has the "HyperTerminal" accessory. For older computers running DOS, various free and nearly-free packages are still available (such as Telix by DeltaComm, <http://www.telix.com>).

### 1.3.5. Step-By-Step Example For First-Time Use

The following steps outline how the first-time user should setup his or her computer and pulse generator so that they can communicate via the RS-232 connection:

1. Obtain the proper "straight-through" RS-232 cable to connect the computer to the pulse generator. (An RS-232 cable is not supplied with the pulse generator, since there is more than one variant.) The pulse-generator end of the cable will require a 25-pin male connector.

The computer end of the cable will (probably) require a 9-pin or 25-pin female connector. If you have a cable with the correct connectors, but are uncertain of whether or not it is a "straight-through" cable, you can check the cable wiring with an ohmmeter, and compare the results to the "Cable Connections" diagrams above.

2. Select a serial port on your computer to use. On most PCs, these are designated COM1: to COM4:, typically. Choose a port that is not in use.

Beware that an internal modem may be connected to a port, even if the computer's external connector has nothing connected to it.

Also beware that in computers with three or more serial ports, two or more serial ports may share the same system resources and thus can not be used at the same time. For instance, on many IBM PC type computers, COM1: and COM3: share an interrupt, as do COM2: and COM4:. Thus you can not connect devices to COM1: and COM3: and use them at the same time. Similarly you can not connect devices to COM2: and COM4: and use them at the same time.

3. Turn on the pulse generator if it is not already on.
4. Load your serial port terminal software. (As noted above, the "Terminal" and "HyperTerminal" packages supplied with Windows 3.1 and Windows 95 will work. Many other programs are also available.)
5. The next step is to configure the terminal software to the appropriate settings. The following example assumes that you are using Windows 95 HyperTerminal:

- double-click on the "Hypertrm.exe" icon in the HyperTerminal folder. (This folder is probably in your "Accessories" folder.

- when it asks you to enter a connection name, enter "pulse generator", or any other appropriate name. Then click "OK".

- when it asks for a phone number, leave that space blank and click on the entry that says "Connect using:". (This box probably has the name of an installed modem in it.) Select the "Direct to Com N" choice, where N is the number of the COM port that you will use. Then click "OK".

- The "Port Settings" dialog box should now appear. Set "Bits per second" to 1200, "Data bits" to 8, "Parity" to "None", "Stop bits" to 1, "Flow Control" to "Hardware", and click "OK".

6. The software should be ready to use. Press the enter key, and type "remote". Press the enter key again. The OP1B should respond with "Ready for command:". The instrument display should say "RS232 CTRL" to indicate that it is in the RS-232 remote control mode. If it does not, something is wrong.
7. Type "\*idn?" and press enter. The OP1B should reply with "Avtech Electrosystems", followed by the instrument model number, the serial number, and the firmware revision number.

If all of these steps are successful, you are ready to transmit commands and receive data from the pulse generator.

## 1.4. Introduction to the GPIB IEEE-488.2 Bus

### 1.4.1. Introduction

The General Purpose Interface Bus (GPIB) is an interface specifically designed for interconnecting electronic test equipment and computers. This bus has been standardized by the IEEE under standards IEEE-488.1 (related to hardware) and IEEE-488.2 (relating to software). (An instrument which complies with IEEE-488.2 automatically complies with IEEE-488.1.)

The GPIB is much more flexible than the RS-232 control method. Up to 15 devices can be connected simultaneously to the GPIB. The devices can be connected in a linear or star fashion, or any combination of linear and star, as illustrated below:

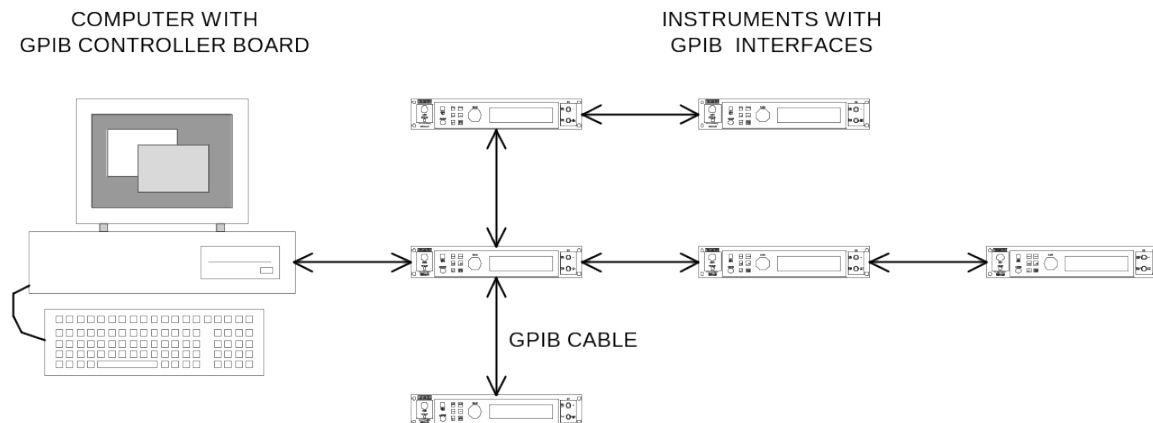

More than one computer controller can be present on the bus, if desired. Each device on the bus has its own address, in the range of 0 to 30.

When using the GPIB, these rules should be followed:

1. Each instrument (including controllers) must have its own address, in the range of 0-30.
2. Do not connect more than 15 devices to the GPIB.
3. The maximum cabling length should be limited to  $(2 \text{ meters}) \times (\text{the number of devices})$ , or 20 meters, whichever is less.
4. At least two-thirds of the devices must be turned-on for the GPIB to be used.
5. Connect the devices in a linear or star configuration as shown above. Do not use loop or parallel connections.

The standard GPIB cable connector is designed to be stackable, so that any number of cables can connect to the same point.

### 1.4.2. Controller and Cabling Requirements

To use a personal computer as a GPIB controller, a GPIB controller board and its associated software must be installed in the computer. (Unlike the RS-232 port, they are not usually included in computers when purchased.) The largest, and recommended, manufacturer of controller boards is National Instruments (<http://www.ni.com/>). National Instruments also sells the necessary cabling. L-Com is also a good source for cables, (<http://www.L-com.com/>) and sells a wider variety of cables than National Instruments.

### 1.4.3. Step-By-Step Example For First-Time Use

The following steps outline how the first-time user should setup his or her computer and pulse generator so that they can communicate via the GPIB bus:

1. Pulse generators with the OP1B option are shipped with the OP1B address set at 8. If there is another instrument on the bus with that address, one of them will have to be changed. If you elect to change the OP1B address, turn on the pulse generator, and press the MOVE button until it points to the "Setup menu" item. Press CHANGE. A new menu should appear, with the arrow pointing at "GPIB address". Press CHANGE again. Then rotated the ADJUST knob, as indicated on the display, until the GPIB address is set to its new desired value. Then press CHANGE to lock in the new value.
2. Make sure that a GPIB controller board and its associated software has been installed in the computer. Connect the pulse generator to the computer using the cable that is supplied with the pulse generator. (If other GPIB cables are available, they may be used instead.)
3. Configure the GPIB software to recognize the pulse generator. For instance, if you have a National Instruments controller running on a computer with Windows 95, do the following:
  - click on the Windows 95 "Start" button
  - click on the "Settings" selection
  - click on "Control Panel"
  - when the Control Panel folder is displayed, click on "System"
  - when the "System Properties" folder is opened, click on the "Device Manager" tab
  - Click on the "National Instruments GPIB Interfaces" selection, and then click the "Properties" button.
  - Then click on the "Device Templates" tab. Click on an unused device name, such as DEV8, so that it is highlighted.
  - Click on the highlighted device name so that a cursor appears, and rename the device to something meaningful like "Avtech". This is the new device name.
  - Click on the Primary GPIB Address box, and set the address to equal the OP1B's address (usually 8, unless changed previously.)
  - The other settings can be left at their default values. Click "OK" as many times as required to escape the Control Panel.

For older National Instruments board running under older operating systems, the appropriate configuration program is called "ibconf".

4. Turn on the pulse generator if it is not already on.
5. Run the GPIB program that allows you to send commands directly to the GPIB bus. For National Instruments boards this is called "ibic", or "Win32 Interactive Control".
6. Execute the program command that opens the device name "Avtech". For instance, the appropriate ibic command is: `ibfind avtech`
7. Execute the program command that sends the string "\*idn?" to the GPIB bus. For instance, the appropriate ibic command is: `ibwrt "*idn?"`

At this point, the pulse generator display should read "GPIB CTRL". If it does not, something is wrong.

8. Execute the program command that reads 100 bytes from the GPIB bus. For instance, the appropriate ibic command is: `ibrd 100`

The program should reply with "Avtech Electrosystems", followed by the instrument model number, the serial number, and the firmware revision number. (Fewer than 100 bytes will actually be read.)

#### 1.4.4. IEEE 488.1 Interface Functions

The IEEE 488.1 standard defines a specific manner of documenting the instrument's GPIB interface in terms of "interface functions". The OP1B interface implements the following IEEE 488.1 Interface Functions:

- **SH1** (Source Handshake). The instrument can transmit multiline messages across the GPIB.
- **AH1** (Acceptor Handshake). The instrument can receive multiline messages across the GPIB.
- **T6** (Talker). The instrument becomes a talker when the controller sends its talk address with the ATN (attention) line asserted. It can respond to a serial poll. It ceases to be a talker when the controller sends another device's talk address with ATN asserted. The instrument does not have talk-only capability.
- **L4** (Listener). The instrument becomes a listener when the controller sends its listen address with the ATN (attention) line asserted. The instrument does not have listen-only capability.
- **SR1** (Service Request). The instrument asserts the SRQ (Service Request) line to notify the controller when it requires service.
- **RL1** (Remote Local). The instrument responds to both the GTL (Go To Local) and the LLO (Local Lockout) messages.
- **PP0** (Parallel Poll). The instrument has no parallel poll capability.
- **DC1** (Device Clear). The instrument responds to the DCL (Device Clear) message, and when made a listener, the SDC (Selected Device Clear) messages.
- **DT0** (Device Trigger). The instrument has no device trigger capability.
- **C0** (Controller). The instrument can not control other devices.
- **E2** (Electrical). Three-state drivers are used in the transceivers.

#### 1.4.5. End-of-String (EOS) Issues

When a controller sends a message to a GPIB-connected instrument, such as an Avtech pulse generator, two methods can be used to indicate the end of the message.

The first, and most common, method is to assert the End-or-Identify (EOI) hardware signal on the GPIB cable. Most software does this automatically when sending messages, by default, so that the user doesn't need to worry about manually terminating the message.

If the software does not automatically use the EOI method, the user can manually add an End-of-String (EOS) character to terminate the message. The EOS character is the null character, ASCII code 0. This is not a standard keyboard character, so the user will need to know the software-specific method of adding a null character to the message. With Windows-based National Instruments controllers, this is achieved by using a backslash followed by a zero, like so:

```
ibwrt "output on\0"
```

For HTBasic programming, you may need to append the "END" token to the command, like so:

```
OUTPUT 715;"OUTPUT ON",END
```

Other software packages will have different methods of adding an EOS character.

One or both of these messages *must* be used to terminate the message. If neither is used, the instrument will "freeze", as it waits for a termination message.

#### **1.4.6. Other GPIB Notes**

The size of the OP1B GPIB data buffer is 512 bytes. This buffer can not overflow; the system interface will prevent further data transfer. (However, the maximum length of a single command message or a single compound command message that is to be parsed is 512 bytes. Longer messages will not be parsed properly and will generate an error.)

#### **1.4.7. Debugging GPIB Problems**

If you suspect that your GPIB controller and the attached instrument are not communicating properly, or that a particular sequence of commands is causing the attached instrument to act in an unexpected manner, there are two methods of observing the controller-instrument communications.

The first, and best, method is to use a GPIB analyzer device. Some premium controller boards have this feature built-in. They allow eavesdropping of the inter-device communications, right down to the level of watching the individual signal lines change. The National Instruments ([www.ni.com](http://www.ni.com)) "AT-GPIB/TNT+", "PCMCIA-GPIB+", and "PCI-GPIB+" products are examples of controller/analyzers.

The second is to use a software utility, such as the National Instruments "NI-Spy" program. This program, or a similar one, is usually supplied with a GPIB controller card. This utility allows the user to view the software calls that are made to the controller card by the software on the computer. This will allow you to confirm that the commands are being sent in the order that you expect. Typically, however, they do not offer eavesdropping of the GPIB bus itself, so these utilities are less useful than a full analyzer device.

#### **1.4.8. GPIB Troubleshooting Checklist**

Most GPIB-related problems reported to Avtech are a result of EOS/EOI issues, as described in section 1.4.5. However, if this does not seem to be the problem, this checklist may be of assistance in debugging the problem, or in supplying useful information to Avtech technical support staff:

- Is the problem random or repeatable?
- Have you confirmed that you are using the correct GPIB address? The address that is assigned to an Avtech instrument may be viewed and changed from the front-panel "Setup" menu. Your software settings will need to match this address. When shipped from the factory, Avtech instruments are preset to address 8.
- Do other GPIB-connected instruments work? If not, the controller may be improperly configured.
- Have you tried another GPIB cable?
- Is your cabling within the limits set by the IEEE-488.1 standard? The maximum permitted cable length is the lesser of 20 meters, or 2 meters multiplied by the number of attached instruments. Caution is advised if any distance between two adjacent instruments exceeds 4 meters.
- If the instrument is "freezing up" after a command is sent, make sure that the proper message termination method is being used (EOI, EOS or both), as described in section 1.4.5.

- ❑ Is the instrument responding to any commands at all? Is it failing after a particular command sequence?
- ❑ Is your controller board IEEE-488.1-1987 and IEEE-488.2-1987 compliant, or was it designed based on earlier (obsolete) standards?
- ❑ Is the front panel liquid-crystal display active or blank? If it is blank after start-up, that may be indicative of an internal power supply problem. Contact Avtech ([info@avtechpulse.com](mailto:info@avtechpulse.com)) in this case.
- ❑ Have you tested the instrument with a different controller? Avtech uses Microsoft Windows-based computers with National Instruments ([www.ni.com](http://www.ni.com)) controller cards in its development and testing facilities, so it would be helpful to know if a problem instrument has been tested at the user's facilities with similar a computer/controller combination. (Avtech instruments are configured and calibrated at the factory using the instrument's GPIB port.)
- ❑ Does the instrument work if you send commands using the RS-232 serial port connection, instead of the GPIB port?
- ❑ Have you confirmed that your AC power supply is reasonably close to the nominal 120V or 240V values?



## 2. Programming Commands

### 2.1.1. **Command Format**

The OP1B command set is based on the IEEE 488.2 and SCPI (Standard Commands for Programmable Instruments) industry standards.

The command set is based on a hierarchical "tree" structure, and command strings are formed by a series of keywords separated by colons. For instance, most of the commands for setting pulse parameters are under the "source:pulse" hierarchy. Examples of such commands are:

```
"source:pulse:width 100ns"  
"source:pulse:delay 200ns".
```

Some "nodes" in the hierarchy are default nodes, and do not need to be explicitly included in the command string. The "source" node is the default top-level node, so the above example commands can be shortened to

```
"pulse:width 100ns"  
"pulse:delay 200ns"
```

Most keywords have a long form and a short form. The short forms of the above commands are:

```
"puls:widt 100ns"  
"puls:del 200ns"
```

Only the long and short forms can be used. Other variants will generate an error.

When defining commands in this manual, default nodes will be indicated with square brackets "[]", and the keyword short forms will be denoted by upper-case letters. Numeric parameters will be referred to as <numeric value>, and boolean (i.e., "ON", "OFF", "0", or "1") parameters will be referred to as <boolean value>. The above two commands would then be referred to as:

```
[SOURce]:PULSe:WIDTh <numeric value>  
[SOURce]:PULSe:DELay <numeric value>
```

In some cases, a choice of keywords is available. This choice is indicated with a "|". For instance, in the sequence:

```
[SOURce]:FREQuency:[CW | FIXed]
```

either CW or FIXed can be used.

### 2.1.2. **Numeric Values**

Commands that require a numeric parameter, such as the two discussed above, are flexible in the way that they handle numbers. Units and exponential notation can be used. For instance, the following commands can all be used to set the frequency to 1 kHz:

```
source:frequency 1000Hz  
source:frequency 1 kHz  
source:frequency 1000  
source:frequency 1e+3  
source:frequency 1e-3 MHz
```

### 2.1.3. Units

The following table lists the units may be included as part of numeric values. (Any combination of upper-case and lower-case may be used; the parser is case-insensitive.) Numeric values without units are assumed to be in terms of the fundamental units (s, Hz, V, A, PCT, or OHM). All query commands which return a numeric value return the value without units, and are in terms of the fundamental units (s, Hz, V, A, PCT, or OHM).

Type	Allowed Units	Meaning	Notes
Time	EXS	$10^{18}$ seconds	
	PES	$10^{15}$ seconds	
	TS	$10^{12}$ seconds	
	GS	$10^9$ seconds	
	MAS	$10^6$ seconds	
	KS	$10^3$ seconds	
	S	$10^0$ seconds	
	MS	$10^{-3}$ seconds	
	US	$10^{-6}$ seconds	
	NS	$10^{-9}$ seconds	
	PS	$10^{-12}$ seconds	
	FS	$10^{-15}$ seconds	
	AS	$10^{-18}$ seconds	
Frequency	EXHZ	$10^{18}$ Hertz	
	PEHZ	$10^{15}$ Hertz	
	THZ	$10^{12}$ Hertz	
	GHZ	$10^9$ Hertz	
	MAHZ	$10^6$ Hertz	Two units for $10^6$ Hertz, MAHZ and MHZ
	MHZ	$10^6$ Hertz	
	KHZ	$10^3$ Hertz	
	HZ	$10^0$ Hertz	
			No unit for $10^{-3}$ Hertz, MHZ is used for $10^6$ Hertz instead.
	UHZ	$10^{-6}$ Hertz	
	NHZ	$10^{-9}$ Hertz	
	PHZ	$10^{-12}$ Hertz	
	FHZ	$10^{-15}$ Hertz	
AHZ	$10^{-18}$ Hertz		
Voltage	EXV	$10^{18}$ Volts	
	PEV	$10^{15}$ Volts	
	TV	$10^{12}$ Volts	
	GV	$10^9$ Volts	
	MAV	$10^6$ Volts	
	KV	$10^3$ Volts	
	V	$10^0$ Volts	
	MV	$10^{-3}$ Volts	
	UV	$10^{-6}$ Volts	
	NV	$10^{-9}$ Volts	
	PV	$10^{-12}$ Volts	
	FV	$10^{-15}$ Volts	
	AV	$10^{-18}$ Volts	
Current	EXA	$10^{18}$ Amperes	
	PEA	$10^{15}$ Amperes	
	TA	$10^{12}$ Amperes	
	GA	$10^9$ Amperes	

Type	Allowed Units	Meaning	Notes
	MAA	10 <sup>6</sup> Amperes	
	KA	10 <sup>3</sup> Amperes	
	A	10 <sup>0</sup> Amperes	
	MA	10 <sup>-3</sup> Amperes	
	UA	10 <sup>-6</sup> Amperes	
	NA	10 <sup>-9</sup> Amperes	
	PA	10 <sup>-12</sup> Amperes	
	FA	10 <sup>-15</sup> Amperes	
	AA	10 <sup>-18</sup> Amperes	
Per Cent (Duty Cycle)	PCT OR %	10 <sup>0</sup> Per Cent	PCT is preferred over %, for compatibility with other equipment.
	MPCT OR M%	10 <sup>-3</sup> Per Cent	
	UPCT OR U%	10 <sup>-6</sup> Per Cent	
	NPCT OR N%	10 <sup>-9</sup> Per Cent	
	PPCT OR P%	10 <sup>-12</sup> Per Cent	
	FA OR F%	10 <sup>-15</sup> Amperes	
	AA OR A%	10 <sup>-18</sup> Amperes	
Resistance, Impedance	OHM	10 <sup>0</sup> Ohms	

#### 2.1.4. Query Commands

Most commands that can be used to set a value also have a query form to read back the value of the setting. For instance, to determine what frequency the pulse generator is currently set at, the query command

```
source:frequency?
```

would be used. Query commands end with a "?". The OP1B interface then return the frequency setting (in the fundamental units, Hertz).

No queries return more than one response message unit, as defined in IEEE 488.2. All responses are generated as soon as the query is received, and not when the controller actually reads the response.

#### 2.1.5. Minimum and Maximum Values

All commands that accept a numeric parameter will also accept the special parameters "MIN", "MINIMUM", "MAX", or "MAXIMUM". This will instruct the OP1B to automatically set the parameter to the lowest or highest allowed value consistent with the other settings. As an example, to set the pulse width to its highest allowed value, use the command:

```
pulse:width max
```

These special parameters can also be used with query commands. For instance, to determine what the highest allowed pulse width actually is, use the command:

```
pulse:width? max
```

#### 2.1.6. Multi-channel Instruments

Some instruments have more than one output channel, and thus a method is required of specifying which channel the command is to affect. This is accomplished by simply adding the channel number to the end of the command header. The channel numbers start at 1, not 0. For example:

```
pulse:width2 500ns      - this sets the Channel 2 pulse width
source:volt1 20V        - this sets the Channel 1 voltage
```

Only add channel numbers to those commands that require them. Commands that affect all channels simultaneously will generate an error a channel number is used.

If no channel number is specified for a command in which they are allowed, channel 1 will be assumed.

### 2.1.7. Compound Messages

The simplest way to send commands to the OP1B is one at a time, like so:

```
freq 100 kHz
pulse:width 1 us
volt 20
```

"Compound commands" can also be used. A compound command is a string of normal commands separated by semicolons. The display and the actual parameters are not updated until all of the individual commands in the compound command have been received, which reduces overhead time. An example of a compound command is:

```
sour:pulse:width 1us;delay 2us;double off
```

The first command in the compound message sets the "tree level" for the remaining individual commands. For instance, the tree level of the first command in the above example is "sour:pulse". The remaining commands are assumed to be of the same tree level, so the OP1B actually interprets the second and third commands as "sour:pulse:delay 2us" and "sour:puls:double off". Adding the tree level to the second and third commands manually would have generated an error. For instance, this is not a legal compound command:

```
sour:pulse:width 1us;sour:pulse:delay 2us;sour:pulse:double off
```

The tree level set by the first command may be temporarily overridden within the compound command by adding a colon in front of the individual command in question. For instance:

```
sour:pulse:width 1us;:source:volt 10;delay 2us;double off
```

is allowed, even though "source:volt" is not part of the "sour:puls" hierarchy. The semicolon does not affect the last two commands since it is a temporary override.

Commands in the IEEE 488.2 common command hierarchy (which start with an asterisk) automatically temporarily override the tree level, and can be included in a compound command at any point. For instance:

```
sour:pulse:width 1us;*rst;delay 2us;double off
```

is allowed.

### 2.1.8. Maximum Command Lengths

The maximum length of a single command message or a single compound command message that is to be parsed is 512 bytes. Longer messages will not be parsed properly and will generate an error.

Within this limitation, numeric parameters can be of any length. They will be rounded off to the precision of the internal software.

### **2.1.9. Command Execution Order and Coupled Commands**

All commands are executed in the order that they are received. All commands are executed sequentially. That is, no new commands are executed until the current command is finished.

Because of this, care must be taken when sending multiple commands to the OP1B, so that no limits are exceeded between commands. For instance, consider the example of a pulse generator with a duty cycle limit of 20%. If the frequency is set at 1 kHz, and the pulse width is 100 $\mu$ s, the duty cycle is 10%. If the user then wishes to change the pulse width to 1ms, and the frequency to 100 Hz (again 10% duty cycle) the frequency must be lowered first, and then the pulse width increased. If the pulse width is increased first, the settings immediately afterwards would be 1 kHz and 1ms, giving 100% duty cycle and an error. The pulse generator would recognize this error and would not change the pulse width.

This particular problem can be avoided by using the [SOURce]:PULSe:HOLD DCYCLe command, to hold the duty cycle constant during frequency changes.

Another potential coupling problem arises in pulse generators with an offset capability. If the amplitude and offset are both to be changed, care must be taken not to exceed the maximum output voltage or current (i.e. maximum amplitude+offset) between commands.

### **2.1.10. Execution Speed**

The time to execute a command is typically < 150 ms, in a single-channel instrument.

## 2.2. The DIAGNOSTIC Command Hierarchy

This section describes the commands starting with the keyword "DIAGNOSTIC". These commands provide various calibration functions, and are infrequently used.

### 2.2.1. Tree Structure:

<u>Keyword</u>	<u>Parameter</u>	<u>Notes</u>
DIAGnostic:		
:AMPLitude		
:CALibration:	<numeric value>	[no query form]
:MONitor		
:CALibration:	<numeric value>	[no query form]
:STEP	<numeric value>	
:OFFSet		
:CALibration	<numeric value>	[no query form]

### 2.2.2. DIAGnostic:AMPLitude:CALibration

This command can be used to calibrate the output amplitude, if the set amplitude value does not agree exactly with a measured value. To adjust the calibration, use this command and submit your measured value as the numeric parameter. The internal software will compare the measured value to the latest amplitude setting, and the internal calibration memory will then be adjusted appropriately.

Examples of valid commands are:

- diag:ampl:cal 52 V            - if the programmed amplitude is 50V, but the measured value is 52V, this command will adjust the calibration appropriately.
- diag:ampl:cal 470 mA        - if the programmed amplitude is 500 mA, but the measured value is 470 mA, this command will adjust the calibration appropriately.

This command does not have a query form.

### 2.2.3. DIAGnostic:MONitor:CALibration

This command can be used to calibrate the output current monitor, if the monitor readings do not agree exactly other measured values. This command is only useful on instrument that have the current monitor feature.

To adjust the monitor calibration, use this command and submit your measured value as the numeric parameter. The internal software will compare the measured value to the latest current monitor reading, and the internal calibration memory will then be adjusted appropriately.

Examples of valid commands are:

- diag:mon:cal 5.2 A            - if the monitor reading is 5.0A, but the measured value is 5.2A, this command will adjust the calibration appropriately.

In multi-channel instruments with current monitors, the current monitors are individually adjustable. Add the channel number to the end of the command header.

This command does not have a query form.

#### **2.2.4. DIAGnostic:MONitor:STEP**

Some pulsed-constant current generators have an output-current monitor feature, which displays the measured current amplitude on the front-panel display. The resolution, or step-size, of this readout can be adjusted, if desired. The step size can not be set smaller than 1/5000, or larger than 1/5, of the maximum amplitude that the instrument is capable of generating.

Examples of valid commands are:

diag:mon:step 5mA	- the monitor will increment and decrement in 5 mA steps.
diag:mon:step?	- returns the current step-size.

After power-up or the \*RST command, this function defaults to the same setting as the last time the instrument was on.

In multi-channel instruments with current monitors, this command affects all current monitors simultaneously. The monitor step-sizes are not individually adjustable.

#### **2.2.5. DIAGnostic:OFFSet:CALibration**

For instrument with a DC offset feature, this command can be used to calibrate the output offset, if the set amplitude value does not agree exactly with a measured value. To adjust the calibration, use this command and submit your measured value as the numeric parameter. The internal software will compare the measured value to the latest amplitude setting, and the internal calibration memory will then be adjusted appropriately.

Examples of valid commands are:

diag:offset:cal 52 V	- if the programmed offset is 50V, but the measured value is 52V, this command will adjust the calibration appropriately.
diag:offset:cal 470 mA	- if the programmed offset is 500 mA, but the measured value is 470 mA, this command will adjust the calibration appropriately.

This command does not have a query form.

## 2.3. The DISPLAY Command Hierarchy

This section describes the commands starting with the keyword "DISPLAY". These commands affect the operation of the front panel liquid crystal display (LCD).

### 2.3.1. Tree Structure:

<u>Keyword</u>	<u>Parameter</u>	<u>Notes</u>
DISPlay:		
:BRIGhtness	<numeric value>	

### 2.3.2. DISPlay:BRIGhtness

Most Avtech instruments allow the LCD backlight to be turned on and off. The backlight is normally on at start-up. The backlight can be turned off to reduce power consumption. Doing so will save approximately 5 Watts of power.

Examples of valid commands are:

disp:brig 1	- turns the backlight on
disp:brig 0	- turns the backlight off
disp:brig?	- returns "0" (if off) or "1" (if on)

After power-up or the \*RST command, this function defaults to "1" (on).



## 2.4. The MEASURE Command Hierarchy

This section describes the commands starting with the keyword "OUTPUT". These commands set various parameters related to the pulse generator output stage.

### 2.4.1. Tree Structure:

<u>Keyword</u>	<u>Parameter</u>	<u>Notes</u>
MEASure:		
:AMPLitude?		[query only]

### 2.4.2. MEASure:AMPLitude?

This command is only available on instruments with a computer-readable current monitor. It returns the amplitude, as measured by current monitor circuit.

This command has a query form only.

## 2.5. The OUTPUT Command Hierarchy

This section describes the commands starting with the keyword "OUTPUT". These commands set various parameters related to the pulse generator output stage.

### 2.5.1. Tree Structure:

<u>Keyword</u>	<u>Parameter</u>	<u>Notes</u>
OUTPut:		
:[STATE]	<boolean value>	
:IMPedance	<numeric value>	
:LOAD	50   10000	
:PROTection		
:TRIPped?		[query only]
:TYPE	TTL   ECL	

### 2.5.2. **OUTPut:[STATE] <boolean value>**

### 2.5.3. **OUTPut:[STATE]?**

This enables or disables the pulse generator output. Pulsing only occurs if this is set to "1" or "ON". Examples of valid commands are:

output on	- turns on the pulse generator output
output off	- turns off the pulse generator output
output 0	- turns off the pulse generator output
output?	- returns "0" (if off) or "1" (if on)

After power-up or the \*RST command, this function defaults to "OFF".

### 2.5.4. **OUTPut:IMPedance <numeric value>**

### 2.5.5. **OUTPut:IMPedance?**

Some pulse generators have switchable output impedances. This command is used to control this feature. Examples of valid commands are:

output:impedance 50	- sets the output impedance to 50 Ohms.
output:impedance 2 Ohm	- sets the output impedance to 2 Ohms.
output:impedance?	- returns the current output impedance setting.

After power-up or the \*RST command, this function defaults to the minimum allowed value.

### 2.5.6. **OUTPut:LOAD 50 | 10000**

### 2.5.7. **OUTPut:LOAD?**

Some pulse generators have duty cycle limits that depend on the type of load attached to the pulse generator output. This command is used to advise the pulse generator of what type of load is attached. "50" indicates a 50Ω load, "10000" is used for loads of > 10kΩ. Examples of valid commands are:

output:load 50	- the load impedance is 50Ω.
output:load 10000	- the load impedance is > 10kΩ.
output:load?	- returns "50" or "10000" as appropriate.

After power-up or the \*RST command, this function defaults to "50".

#### **2.5.8. *OUTPut:PROTection:TRIPped?***

This command has a query form only. If the pulse generator's output protection circuits are currently tripped due to improper use or malfunction, then this command will return a "1". In normal operation, this command will return "0".

#### **2.5.9. *OUTPut:TYPE TTL | ECL***

#### **2.5.10. *OUTPut:TYPE?***

Some pulse generators have auxiliary logic outputs, nominally synchronous with the main output, which can supply either TTL-level or ECL-level signals. (TTL levels are nominally 0V and +5V, ECL levels are nominally -1.6V and -0.8V.) This command is used to select the logic levels that are generated. Examples of valid commands are:

output:type ECL	- the logic outputs provide ECL-level outputs.
output:type?	- returns the current logic-level setting.

After power-up or the \*RST command, this function defaults to TTL.

## 2.6. The ROUTE Command Hierarchy

This section describes the commands starting with the keyword "ROUTE". Some instruments have several separate internal channels, which are routed to a common output connector. This command hierarchy is used to select which signal is routed to the output connector, if the instrument supports this feature.

### 2.6.1. Tree Structure:

<u>Keyword</u>	<u>Parameter</u>	<u>Notes</u>
ROUTE:		
:CLOSe	<channel list>	

### 2.6.2. ROUTE:CLOSe

### 2.6.3. ROUTE:CLOSe?

This command selects the channel that is routed to the main output connector. Examples of valid commands are:

route:close (@1)	- channel 1 is routed to the main output connector.
route:close (@2)	- channel 2 is routed to the main output connector.
route:close? (@1)	- this returns a "1" if channel 1 is currently routed to the output connector, and "0" otherwise.
route:close? (@2)	- this returns a "1" if channel 2 is currently routed to the output connector, and "0" otherwise.

Only one channel is connected at a time. The unusual parameter notation is in keeping with the SCPI standard for specifying channel lists.

After power-up or the \*RST command, this function defaults to channel 1.

## 2.7. The SOURCE:CURRENT Command Hierarchy

This section describes the commands starting with the keywords "[SOURce]:CURRent". The commands are only used if your pulse generator is a current pulser. (If it is a voltage pulser, see the SOURCE:VOLTAGE section.) This hierarchy is used primarily to set the output amplitude and offset.

### 2.7.1. Tree Structure:

Keyword	Parameter	Notes
[SOURce]: :CURRent		
[:LEVel]		
[:IMMEdiate]		
[:AMPLitude]	<numeric value>   EXTernal   AMPLIFY	
:LOW	<numeric value>   EXTernal	
:PROTection		
:TRIPped?		[query only]

### 2.7.2. [SOURce]:CURRent:[LEVel]:[IMMEdiate]:[AMPLitude] <numeric value> | EXTernal | AMPLify

### 2.7.3. [SOURce]:CURRent:[LEVel]:[IMMEdiate]:[AMPLitude]?

This command is used to set or read the output current amplitude. Examples of valid commands are:

current 100A	- sets output amplitude to 100A
curr 100mA	- sets output amplitude to 100mA
source:curr 10	- sets output amplitude to 10A
current?	- returns the output amplitude setting, in amperes.

Some pulse generators allow the amplitude to be controlled by an external voltage applied to a connector on the rear panel of the instrument. This mode is enabled by using the "EXT" parameter:

source:current EXT	- output amplitude is controlled by the external signal.
current external	- output amplitude is controlled by the external signal.

Some pulse generators allow the instrument to act as an amplifier for one of the inputs. This mode is enabled by using the "AMP" parameter:

source:current AMP	- sets amplifier mode.
current amplify	- sets amplifier mode.

After power-up or the \*RST command, this function defaults to the minimum allowed value.

### 2.7.4. [SOURce]:CURRent:[LEVel]:[IMMEdiate]:LOW <numeric value> | EXTernal

### 2.7.5. [SOURce]:CURRent:[LEVel]:[IMMEdiate]:LOW?

This command is used to set or read the output current offset, if the pulse generator has an offset capability. Examples of valid commands are:

current:low 100A	- sets output amplitude offset to 100A
curr:low 100mA	- sets output amplitude offset to 100mA

source:curr:low 10 - sets output amplitude offset to 10A  
current:low? - returns the output amplitude offset setting, in amperes.

Some pulse generators allow the offset to be controlled by an external voltage applied to a connector on the rear panel of the instrument. This mode is enabled by using the "EXT" parameter:

source:current:low EXT - output offset is controlled by the external signal.  
Current:low external - output offset is controlled by the external signal.

After power-up or the \*RST command, this function defaults to the minimum allowed value.

#### **2.7.6. [SOURce]:CURRent:PROTection:TRIPped?**

This command has a query form only. If the pulse generator's output protection circuits are currently tripped due to improper use or malfunction, then this command will return a "1". In normal operation, this command will return "0".

## 2.8. The SOURCE:FREQUENCY Command Hierarchy

This section describes the commands starting with the keywords "[SOURCE]:FREQUENCY". These commands affect the frequency setting of the pulse generator (if the pulse generator has a variable internal clock).

### 2.8.1. Tree Structure:

<u>Keyword</u>	<u>Parameter</u>	<u>Notes</u>
[SOURCE]: :FREQUENCY	[CW   FIXEd] <numeric value>	

### 2.8.2. [SOURCE]:FREQUENCY:[CW | FIXEd] <numeric value>

### 2.8.3. [SOURCE]:FREQUENCY:[CW | FIXEd]?

This command is used to set or read the output pulse repetition frequency (PRF). Examples of valid commands are:

frequency 100 Hz	- sets the frequency at 100 Hz
freq 1kHz	- sets the frequency at 1 kHz
sour:freq:fixed 200	- sets the frequency at 200 Hz
freq?	- returns the current frequency setting

After power-up or the \*RST command, this function defaults to the minimum allowed value.

## 2.9. The SOURCE:FUNCTION Command Hierarchy

This section describes the commands starting with the keywords "[SOURCE]:FUNCTION". These commands select the output waveform type.

### 2.9.1. Tree Structure:

<u>Keyword</u>	<u>Parameter</u>	<u>Notes</u>
[SOURCE]: :FUNCTION :[SHAPE]	DC   PULSe	

### 2.9.2. [SOURCE]:FUNCTION:SHAPE DC | PULSe

### 2.9.3. [SOURCE]:FUNCTION:SHAPE?

If the pulse generator has a DC output mode feature, this command enables or disables it. Examples of valid commands are:

func:shape dc	- sets output to a DC level, determined by the SOURCE:VOLTage or SOURCE:CURREnt commands
func:shape pulse	- sets output to pulsed waveform, controlled by the SOURCE:PULSe commands
function:shape?	- returns "DC" or "PULS", as appropriate

After power-up or the \*RST command, this function defaults to "PULSE".



## 2.10. The SOURCE:PULSE Command Hierarchy

This section describes the commands starting with the keywords "[SOURce]:PULSe". These commands set the major pulse timing parameters such as pulse width, duty cycle, and delay.

### 2.10.1. Tree Structure:

<u>Keyword</u>	<u>Parameter</u>	<u>Notes</u>
[SOURce]: :PULSe		
:PERiod	<numeric value>	
:WIDTh	<numeric value>   IN	
:DCYClE	<numeric value>	
:HOLD	WIDTh   DCYClE	
:DELay	<numeric value>	
:DOUBle		
[:STATE]	<boolean value>	
:DELay	<numeric value>	
:POLarity	NORMal   COMPlEment   INVerted	
:GATE		
:TYPE	ASYNc   SYNc	
:LEVel	HIgh   LOw	

### 2.10.2. [SOURce]:PULSe:PERiod <numeric value>

### 2.10.3. [SOURce]:PULSe:PERiod?

This command is used to set or read the output period (i.e., 1/frequency. Note that the [SOURce]:FREQUency command performs a related function.) Examples of valid commands are:

```
pulse:period 100ns    - sets the output period to 100ns
source:puls:per 1e-6  - sets the output period to 1µs
puls:per?             - returns the output period setting, in seconds
```

After power-up or the \*RST command, this function defaults to the maximum allowed value.

### 2.10.4. [SOURce]:PULSe:WIDTh <numeric value> | IN

### 2.10.5. [SOURce]:PULSe:WIDTh?

This command is used to set or read the output pulse width. (Note that the [SOURce]:PULSe:DCYClE command performs a related function.) Examples of valid commands are:

```
pulse:width 100ns    - sets the output pulse width to 100ns
source:puls:wid 1e-6 - sets the output pulse width to 1µs
pulse:width in       - sets the output pulse width to track the external trigger input
                       pulse width, if this feature is present. Only used in external trigger
                       mode.
puls:wid?           - returns the output pulse width setting, in seconds
```

After power-up or the \*RST command, this function defaults to the minimum allowed value.

### 2.10.6. [SOURce]:PULSe:DCYClE <numeric value>

### 2.10.7. [SOURce]:PULSe:DCYClE?

This command is used to set or read the output duty cycle. (Note that the [SOURCE]:PULSE:WIDTH command performs a related function.) Examples of valid commands are:

```
pulse:dcycle 10      - sets the output duty cycle to 10%
source:puls:dcyc 5 pct - sets the output duty cycle to 5%
puls:dcyc?          - returns the output duty cycle setting, in per cent
```

After power-up or the \*RST command, the default duty cycle is determined by the default pulse width and the default frequency.

#### **2.10.8. [SOURCE]:PULSE:HOLD WIDTH | DCYCLE**

##### **2.10.9. [SOURCE]:PULSE:HOLD?**

This command determines whether the pulse width or the duty cycle is held constant when the frequency is changed. Examples of valid commands are:

```
pulse:hold dcycle   - the duty cycle is held constant when the frequency is changed
pulse:hold width    - the pulse width is held constant when the frequency is changed
puls:hold?          - returns the current hold setting, either "WIDT" or "DCYC"
```

After power-up or the \*RST command, this function defaults to "WIDTH".

#### **2.10.10. [SOURCE]:PULSE:DElay <numeric value>**

##### **2.10.11. [SOURCE]:PULSE:DElay?**

This command is used to set or read the delay of the main output relative to the SYNC output. This delay can be positive or negative, generally. Examples of valid commands are:

```
pulse:delay 150ns   - main output pulses will follow SYNC pulses by 150 ns.
source:puls:del -20ns - main output pulses will precede SYNC pulses by 150 ns.
puls:delay?         - returns the delay setting, in seconds
```

After power-up or the \*RST command, this function defaults to +20ns.

#### **2.10.12. [SOURCE]:PULSE:DOUBLE:[STATE] <boolean value>**

##### **2.10.13. [SOURCE]:PULSE:DOUBLE:[STATE]?**

This command is used to turn on or off the double pulse mode. In the double pulse mode, a pulse is generated at the same time as the SYNC pulse, followed by a second delayed pulse. If the double pulse mode is off, only the delayed pulse is generated. The duration of this delay is set by the [SOURCE]:PULSE:DElay and/or [SOURCE]:PULSE:DOUBLE:DElay commands. In the double pulse mode, the delay setting must be positive. Examples of valid commands are:

```
pulse:double on     - turns on double pulse mode
pulse:double 1      - turns on double pulse mode
pulse:double off    - turns off double pulse mode
pulse:double 0      - turns off double pulse mode
puls:doub?          - returns "1" if the double pulse mode is on, "0" otherwise.
```

After power-up or the \*RST command, this function defaults to "OFF".

#### **2.10.14. [SOURCE]:PULSE:DOUBLE:DElay <numeric value>**

##### **2.10.15. [SOURCE]:PULSE:DOUBLE:DElay?**

This command performs the exactly the same function as the [SOURCE]:PULSE:DELAY command described previously.

**2.10.16. [SOURCE]:PULSE:POLarity NORMAL | COMPLEMENT | INVERTed**

**2.10.17. [SOURCE]:PULSE:POLarity?**

This command can be used to logically invert the output pulse on some models. That is, in the inverted mode (also called the complemented mode), the output high and low voltage levels are swapped. (The voltage polarity, positive or negative, does not change.) Examples of valid commands are:

pulse:polarity normal	- sets normal mode
pulse:polarity inverted	- inverts the output pulse
pulse:polarity comp	- inverts the output pulse
pulse:pol?	- returns "NORM" or "COMP" as appropriate.

After power-up or the \*RST command, this function defaults to "NORMAL".

**2.10.18. [SOURCE]:PULSE:GATE:TYPE ASYNC | SYNC**

**2.10.19. [SOURCE]:PULSE:GATE:TYPE?**

This command determines how the gate input functions. If the parameter is "ASYNC", the gate will act asynchronously of the output. That is, when the gate line is asserted the output waveform will stop immediately. Pulses may be truncated. If the "SYNC" parameter is chosen, triggering stops only after the current pulse is completed. No truncation occurs. Examples of valid commands are:

pulse:gate:type async	- sets asynchronous (truncating) gating
pulse:gate:type sync	- sets synchronous (non-truncating) gating
pulse:gate:type?	- returns "ASYNC" or "SYNC" as appropriate

After power-up or the \*RST command, this function defaults to "SYNC".

**2.10.20. [SOURCE]:PULSE:GATE:LEVEL High|Low**

**2.10.21. [SOURCE]:PULSE:GATE:LEVEL?**

This command determines how the gate input functions. If the parameter is "HI", the gate input will halt output triggering when the input is TTL HI (3-5V). If the parameter is "LO", the gate input will halt output triggering when the input is TTL LO (0V). Examples of valid commands are:

pulse:gate:lev hi	- triggering stops when gate is TTL high.
pulse:gate:level?	- returns "HI" or "LO" as appropriate

After power-up or the \*RST command, this function defaults to "LO".

## 2.11. The SOURCE:VOLTAGE Command Hierarchy

This section describes the commands starting with the keywords "[SOURce]:VOLTage". The commands are only used if your pulse generator is a voltage pulser. (If it is a current pulser, see the SOURCE:CURRENT section.) This hierarchy is used primarily to set the output amplitude and offset.

### 2.11.1. Tree Structure:

Keyword	Parameter	Notes
[SOURce]: :VOLTage		
[:LEVel]		
[:IMMEDIATE]		
[:AMPLitude]	<numeric value>   EXTERNAL   AMPLify	
:LOW	<numeric value>   EXTERNAL	
:PROTECTION		
:TRIPPed?		[query only]

### 2.11.2. [SOURce]:VOLTage:[LEVel]:[IMMEDIATE]:[AMPLitude] <numeric value> | EXTERNAL | AMPLify

### 2.11.3. [SOURce]:VOLTage:[LEVel]:[IMMEDIATE]:[AMPLitude]?

This command is used to set or read the output voltage amplitude. Examples of valid commands are:

voltage 100V	- sets output amplitude to 100V
volt 100mV	- sets output amplitude to 100mV
source:volt 10	- sets output amplitude to 10V
voltage?	- returns the output amplitude setting, in volts.

Some pulse generators allow the amplitude to be controlled by an external voltage applied to a connector on the rear panel of the instrument. This mode is enabled by using the "EXT" parameter:

source:volt EXT	- output amplitude is controlled by the external signal.
voltage external	- output amplitude is controlled by the external signal.

Some pulse generators allow the instrument to act as an amplifier for one of the inputs. This mode is enabled by using the "AMP" parameter:

source:volt AMP	- sets amplifier mode.
voltage amplify	- sets amplifier mode.

After power-up or the \*RST command, this function defaults to the minimum allowed value.

### 2.11.4. [SOURce]:VOLTage:[LEVel]:[IMMEDIATE]:LOW <numeric value> | EXTERNAL

### 2.11.5. [SOURce]:VOLTage:[LEVel]:[IMMEDIATE]:LOW?

This command is used to set or read the output voltage offset, if the pulse generator has an offset capability. Examples of valid commands are:

voltage:low 100V	- sets output amplitude offset to 100V
volt:low 100mV	- sets output amplitude offset to 100mV
source:volt:low 10	- sets output amplitude offset to 10V

voltage:low? - returns the output amplitude offset setting, in volts.

Some pulse generators allow the offset to be controlled by an external voltage applied to a connector on the rear panel of the instrument. This mode is enabled by using the "EXT" parameter:

source:voltage:low EXT - output offset is controlled by the external signal.  
volt:low external - output offset is controlled by the external signal.

After power-up or the \*RST command, this function defaults to the minimum allowed value.

#### **2.11.6. [SOURce]:VOLTage:PROTection:TRIPped?**

This command has a query form only. If the pulse generator's output protection circuits are currently tripped due to improper use or malfunction, then this command will return a "1". In normal operation, this command will return "0".

## 2.12. The STATUS Command Hierarchy

This section describes the commands starting with the keywords "STATus". These commands do not perform any useful function in the OP1B, but are included to satisfy the SCPI industry-standard.

### 2.12.1. Tree Structure:

<u>Keyword</u>	<u>Parameter</u>	<u>Notes</u>
STATUS:		
:OPERation		
:[EVENT]?		[query only, always returns "0"]
:CONDition?		[query only, always returns "0"]
:ENABLE	<numeric value>	[implemented but not useful]
:QUEStionable		
:[EVENT]?		[query only, always returns "0"]
:CONDition?		[query only, always returns "0"]
:ENABLE	<numeric value>	[implemented but not useful]

## 2.13. The SYSTEM Command Hierarchy

This section describes the commands starting with the keyword "SYSTEM". These commands set various parameters related to the OP1B computer interface, such as communications and error reporting.

### 2.13.1. Tree Structure:

<u>Keyword</u>	<u>Parameter</u>	<u>Notes</u>
SYSTem:		
:COMMunicate		
:GPIB		
:ADDRes	<numeric value>	
:SERial		
:CONTRol		
:RTS	ON   IBFull   RFR	
:[RECeive]		
:BAUD	1200   2400   4800   9600	
:BITS	7   8	
:ECHO	<boolean value>	
:PARity		
:[TYPE]	EVEN   ODD   NONE	
:SBITS	1   2	
:ERRor		
:[NEXT]?		[query only]
:COUNT?		[query only]
:VERSion?		[query only]

### 2.13.2. SYSTem:COMMunicate:GPIB:ADDRes <numeric value>

### 2.13.3. SYSTem:COMMunicate:GPIB:ADDRes?

This command is used to set or read the GPIB address of the pulse generator. It may be between 0 and 30, and it should be chosen to not conflict with other instruments in your system. Changes in the GPIB address are implemented immediately. Examples of valid commands are:

```

syst:comm:gpiib:address 8    - sets the GPIB talk/listen address to 8
syst:comm:gpiib:address?    - returns the current GPIB talk/listen address

```

After power-up or the \*RST command, this function defaults to the address used before \*RST or the previous power-down.

### 2.13.4. SYSTem:COMMunicate:SERial:CONTRol:RTS ON | IBFull | RFR

### 2.13.5. SYSTem:COMMunicate:SERial:CONTRol:RTS?

This command is used to configure the RS-232 serial port. If the IBFull or RFR parameters are used, the RS-232 RTS is de-asserted when the input buffer is full. This is also known as "RTS/CTS hardware handshaking". It is suggested that this mode be used, since it results in more reliable serial port communications. If the "ON" parameter is used, the RTS line is constantly asserted by the OP1B interface, regardless of the input buffer state. Data can be lost in this mode. Examples of valid commands are:

```

syst:comm:serial:control:rts ibfull - enables RTS/CTS hardware handshaking
syst:comm:serial:control:rts rfr    - enables RTS/CTS hardware handshaking
syst:comm:serial:control:rts on     - disables RTS/CTS hardware handshaking
syst:comm:gpiib:address?           - returns "IBF" or "ON", as appropriate

```

After power-up or the \*RST command, this function defaults to the address used before \*RST or the previous power-down.

**2.13.6. SYSTem:COMMunicate:SERial:[RECeive]:BAUD 1200 | 2400 | 4800 | 9600**

**2.13.7. SYSTem:COMMunicate:SERial:[RECeive]:BAUD?**

This command is used to configure the RS-232 serial port baud rate. The OP1B interface can communicate at 1200, 2400, 4800, or 9600 bits per second. Examples of valid commands are:

```
syst:comm:serial:baud 1200    - sets the baud rate to 1200 bps
syst:comm:serial:baud?      - returns the current baud rate setting
```

After power-up or the \*RST command, this function defaults to the address used before \*RST or the previous power-down.

**2.13.8. SYSTem:COMMunicate:SERial:[RECeive]:BITS 7 | 8**

**2.13.9. SYSTem:COMMunicate:SERial:[RECeive]:BITS?**

This command is used to configure the RS-232 serial port. Its sets the number of data bits used, either 7 or 8. Examples of valid commands are:

```
syst:comm:serial:bits 8      - selects 8 data bits
syst:comm:serial:bits?      - returns the current data bits setting
```

After power-up or the \*RST command, this function defaults to the address used before \*RST or the previous power-down.

**2.13.10. SYSTem:COMMunicate:SERial:[RECeive]:ECHO <boolean value>**

**2.13.11. SYSTem:COMMunicate:SERial:[RECeive]:ECHO?**

This command is used to configure the RS-232 serial port. Its determines whether data received on the port is echoed back to the computer. Examples of valid commands are:

```
syst:comm:serial:echo on     - turns on echoing
syst:comm:serial:echo 1     - turns on echoing
syst:comm:serial:echo?      - returns the current echo setting, either 0 or 1
```

After power-up or the \*RST command, this function defaults to the address used before \*RST or the previous power-down.

**2.13.12. SYSTem:COMMunicate:SERial:[RECeive]:PARity:[TYPE] EVEN | ODD | NONE**

**2.13.13. SYSTem:COMMunicate:SERial:[RECeive]:PARity:[TYPE]?**

This command is used to configure the RS-232 serial port. Its sets the parity of the interface. Examples of valid commands are:

```
syst:comm:serial:parity even - selects even parity
syst:comm:serial:par?       - returns the current parity setting
```

After power-up or the \*RST command, this function defaults to the address used before \*RST or the previous power-down.

**2.13.14. SYSTem:COMMunicate:SERial:[RECeive]:SBITS 1 | 2**

**2.13.15. SYSTem:COMMunicate:SERial:[RECeive]:SBITS?**



This command is used to configure the RS-232 serial port. It sets the number of stop bits used, either 1 or 2. Examples of valid commands are:

sys:comm:serial:sbits 1           - selects 1 stop bit  
sys:comm:serial:sbits?           - returns the current stop bits setting

After power-up or the \*RST command, this function defaults to the address used before \*RST or the previous power-down.

#### **2.13.16.    *SYSTEM:ERROR:[NEXT]?***

This command is used to read error messages from the error queue. Reading an error message removes it from the queue. (This command is only useful if the instrument is controlled via the GPIB. If the instrument is controlled by the front panel or by the RS-232 port, error messages are displayed on the front panel or transmitted over the serial port as soon as they occur.) Examples of valid commands are:

sys:err?                           - returns the most recent error message, if any

#### **2.13.17.    *SYSTEM:ERROR:COUNT?***

This command is used to read the number of unread error messages in the error queue. Examples of valid commands are:

sys:err:count?                   - returns the number of error message in the queue.

#### **2.13.18.    *SYSTEM:VERSION?***

This command returns the SCPI version number to which the command set complies. Examples of valid commands are:

sys:version?                      - returns the SCPI version number.

## 2.14. The TRIGGER Command Hierarchy

This section describes the commands starting with the keywords "TRIGger". These commands select the trigger source for the pulse generator.

### 2.14.1. Tree Structure:

<u>Keyword</u>	<u>Parameter</u>	<u>Notes</u>
TRIGger: :SOURce	INTernal   EXTernal   MANual   HOLD   IMMEDIATE	

### 2.14.2. TRIGger:SOURce INTernal | EXTernal | MANual | HOLD | IMMEDIATE

### 2.14.3. TRIGger:SOURce?

This command selects the trigger source for the instrument. Examples of valid commands are:

trig:sour INT	- selects the internal clock as the trigger source
trig:sour EXT	- selects the external TTL trigger input as the trigger source
trig:sour MAN	- selects the "Single Pulse" pushbutton as the trigger source. Each button press produces one pulse.
trig:sour HOLD	- selects no trigger source (triggering stops)
trig:sour IMM	- generates a single pulse, and then stops triggering. This is the computer-controlled equivalent of the manual "Single Pulse" pushbutton.

After power-up or the \*RST command, this function defaults to "INTERNAL".

### 2.15. The IEEE 488.2 Common Command Hierarchy

This section describes the commands starting with an asterisks. These commands perform a variety of functions, and are "common commands" defined by the IEEE 488.2 standard.

Many of these commands relate to the status and error reporting system defined by the IEEE 488.2 standard. This system is outlined in the figure below. The numbers 0..7 in each register refer to the bit position in the byte-sized register.

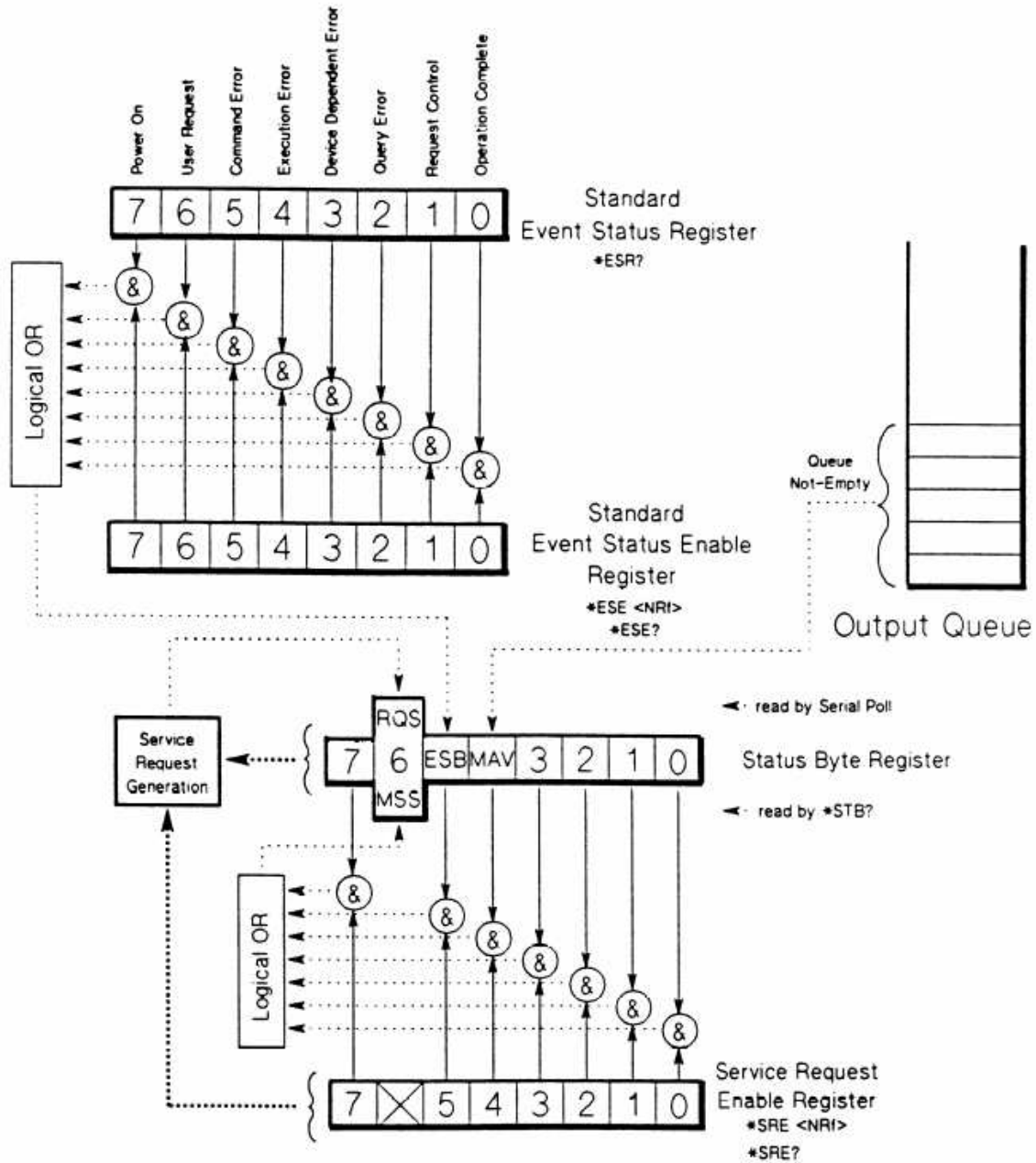

**2.15.1. Tree Structure:**

<u>Keyword</u>	<u>Parameter</u>	<u>Notes</u>
*CLS		[no query form]
*ESE	<numeric value>	
*ESR?		[query only]
*IDN?		[query only]
*OPC		
*SAV	0   1   2   3	[no query form]
*RCL	0   1   2   3	[no query form]
*RST		[no query form]
*SRE	<numeric value>	
*STB?		[query only]
*TST?		[query only]
*WAI		[no query form]

**2.15.2. \*CLS**

This command clears the error queue and the Event Status Register.

**2.15.3. \*ESE <numeric value>****2.15.4. \*ESE?**

This command sets the value of the Event Status Enable register. Individual bits enable the reporting of the error bits in the Event Status Register into the ESB bit of the Status Byte Register. (See the figure). Examples of valid commands are:

- \*ESE 255 - allows all error types reported in the Event Status Register to trigger the ESB bit in the Status Byte Register
- \*ESE? - returns the value of the Event Status Enable register

**2.15.5. \*ESR?**

This command returns the value of the Event Status Register. Bits in the register are set when different types of errors occur. The bits are summarized below:

- *Power On.* Set when the instrument is first turned on.
- *User Request.* Not used.
- *Command Error.* Set when an unrecognized command or an improperly formed command is received.
- *Execution Error.* Set when a properly-formed command can not be executed due to conflicting settings or out-of-range data.
- *Device-Dependent Error.* Set when an overload condition due to improper use or malfunction is detected, or when the error queue has overflowed.
- *Query Error.* Set when data in the GPIB output queue has been overwritten, or when the GPIB controller has tried to read from the instrument when the output queue was empty.
- *Operation Complete.* Set by the OPC command.

**2.15.6. \*IDN?**

This command returns a string of characters including the pulse generator's manufacturer, model name, serial number, and firmware (software) revision number.

**2.15.7. \*OPC**

This command sets the Operation Complete bit in the Event Status Register. (In more complex instruments, this command is used to synchronize overlapping tasks. This instrument completes commands sequentially in a non-overlapping manner, so this command is of little usefulness.)

**2.15.8. \*OPC?**

This command always returns "1". (In more complex instruments, this command is used to synchronize overlapping tasks. This instrument completes commands sequentially in a non-overlapping manner, so this command is of little usefulness.)

**2.15.9. \*SAV 0 | 1 | 2 | 3**

This command takes a "snapshot" of all current instrument settings (except the GPIB and RS-232 communication settings) and saves them in non-volatile memory. The \*RCL command can be used to recall and implement these settings at a later time, even if power has been interrupted. This is designed to simplify frequently performed experiments. Four complete settings snapshots may be stored, at memory locations 0, 1, 2, or 3. Examples of valid commands are:

\*SAV 2 - saves the current pulse generator setup to memory location 2

**2.15.10. \*RCL 0 | 1 | 2 | 3**

This command restore instrument settings stored in the non-volatile memory by the \*SAV command. Examples of valid commands are:

\*SAV 3 - recalls and implements the pulse generator setup stored in memory location 3

**2.15.11. \*RST**

This command resets the pulse generator settings to the same state as after power-up. The output and error queue are not affected, nor are the IEEE 488.2 status reporting registers.

**2.15.12. \*SRE****2.15.13. \*SRE?**

These commands set or read the value of the Service Request Enable Register, which determines what events trigger a GPIB serial poll service request. If bit 5 is set high, the OP1B will generate a GPIB serial poll request if one of the bits in the Event Status Register goes high while the corresponding bit in the Event Status Enable register has been enabled. If bit 4 is set high, the OP1B will generate a GPIB serial poll request when a message becomes available in the output queue. The other bits are not used. If a serial poll request is generated, the RQS bit in the Status Byte Register will go high, and will stay high until a serial poll has been completed.

**2.15.14. \*STB?**

This command returns the value of the Status Byte Register. The MAV bit of this register is high when messages are available and waiting to be read in the output queue. The ESB bit is high when one or more of the bits in the Event Status Register in high, as well as the corresponding enabling bits in the Event Status Enable register. The MSS bit is a summary bit. The other bits are not used.

**2.15.15. \*TST?**

This command returns a "0" when done. Any other value indicates a malfunction. This command does not perform any further functions.

**2.15.16. \*WAI**

This command does nothing. (In more complex instruments, this command is used to synchronize overlapping tasks. This instrument completes commands sequentially in a non-overlapping manner, so this command is of little usefulness.)

## 2.16. The REMOTE/LOCAL Command Hierarchy

This section describes the commands used to switch between the local front-panel control mode and the RS-232 serial port remote-control mode.

These commands are not relevant for GPIB operation. (In the GPIB mode, the GPIB controller software determines when the instrument is in the local front-panel control mode or the GPIB remote control mode.)

### 2.16.1. Tree Structure:

<u>Keyword</u>	<u>Parameter</u>	<u>Notes</u>
REMOTE		
LOCAL		

### 2.16.2. REMOTE

If the instrument is in the local control mode, and it detects the "REMOTE" command on the RS-232 serial port, the instrument switches to remote operation.

### 2.16.3. LOCAL

When the instrument is in the RS-232 remote-control mode, this command will force the instrument back into local mode.

## 2.17. SCPI Conformance Information

The OP1B conforms to the 1996.0 version of "Standard Commands for Programmable Instruments (SCPI)".

As required by SCPI, here is a list of all SCPI confirmed commands, and their syntax, implemented by the OP1B. (Some commands may be disabled in instruments without corresponding functionality. For instance, the SOURce:CURRent and SOURce:VOLTage hierarchies are not generally included together in the same instrument.)

<u>Keyword</u>	<u>Parameter</u>	<u>Notes</u>
DISPlay:		
:BRIGhtness	<numeric value>	
MEASure:		
:AMPLitude?		[query only]
OUTPut:		
:[STATe]	<boolean value>	
:IMPedance	<numeric value>	
:PROTection		
:TRIPped?		[query only]
:TYPE	TTL   ECL	
ROUte:		
:CLOSe	<channel list>	
[SOURce]:		
:CURRent		
[:LEVel]		
[:IMMEDIATE]		
[:AMPLitude]	<numeric value>   EXTERNAL   AMPLify	
:LOW	<numeric value>   EXTERNAL	
:PROTection		
:TRIPped?		[query only]
[SOURce]:		
:FREQuency		
[:CW   FIXed]	<numeric value>	
[SOURce]:		
:FUNCTion		
:[SHAPE]	DC   PULSE	
[SOURce]:		
:PULSE		
:PERiod	<numeric value>	
:WIDTh	<numeric value>   IN	
:DCYCLE	<numeric value>	
:HOLD	WIDTh   DCYCLE	
:DELay	<numeric value>	
:DOUBle		
[:STATe]	<boolean value>	
:DELay	<numeric value>	
:POLarity	NORMAL   COMPLEMENT   INVERTed	
[SOURce]:		
:VOLTage		
[:LEVel]		
[:IMMEDIATE]		
[:AMPLitude]	<numeric value>   EXTERNAL   AMPLify	
:LOW	<numeric value>   EXTERNAL	
:PROTection		



:TRIPped?		[query only]
STATUS:		
:OPERation		
:[EVENT]?		[query only, always returns "0"]
:CONDition?		[query only, always returns "0"]
:ENABLE	<numeric value>	[implemented but not useful]
:QUEStionable		
:[EVENT]?		[query only, always returns "0"]
:CONDition?		[query only, always returns "0"]
:ENABLE	<numeric value>	[implemented but not useful]
SYSTem:		
:COMMunicate		
:GPIB		
:ADDress	<numeric value>	
:SERial		
:CONTRol		
:RTS	ON   IBFull   RFR	
:[RECeive]		
:BAUD	1200   2400   4800   9600	
:BITS	7   8	
:ECHO	<boolean value>	
:PARity		
:[TYPE]	EVEN   ODD   NONE	
:SBITS	1   2	
:ERRor		
:[NEXT]?		[query only]
:COUNT?		[query only]
:VERSion?		[query only]
TRIGger:		
:SOURce	INTernal   EXTernal   MANual   HOLD   IMMEDIATE	
*CLS		[no query form]
*ESE	<numeric value>	
*ESR?		[query only]
*IDN?		[query only]
*OPC		
*SAV	0   1   2   3	[no query form]
*RCL	0   1   2   3	[no query form]
*RST		[no query form]
*SRE	<numeric value>	
*STB?		[query only]
*TST?		[query only]
*WAI		[no query form]

As required by SCPI, here is a list of all commands implemented by the OP1B, which are not part of the SCPI definition:

DIAGnostic:		
:AMPLitude		
:CALibration	<numeric value>	[no query form]
:MONitor		
:CALibration	<numeric value>	[no query form]
:STEP	<numeric value>	
:OFFSet		
:CALibration	<numeric value>	[no query form]

OUTPut:

```
:LOAD                50 | 10000
[SOURce]:
:PULSe
  :GATE
    :TYPE            ASYNC | SYNC
    :LEVel           High | Low
REMOTE
LOCAL
```

## 3. Error Handling and Error Messages

### 3.1. Error Handling

The OP1B interface contains extensive error-checking software to protect the instrument from incorrect settings. For instance, when a command with out-of-range values is received, the command is ignored and an error is reported.

Whenever an error occurs, it is logged in an error queue, which can hold up to 32 errors. (If more errors than occur, the last error report is replaced with a "queue overflow" error.) Error reports can be viewed and removed from the queue by using the `SYSTEM:ERROR:[NEXT]?` query. The number of errors in the queue can be determined using the `SYSTEM:ERROR:COUNT?` query.

When an error occurs, the Event Status Register will also be updated (see the "The IEEE 488.2 Common Command Hierarchy" section for more details.) Bits in this byte-sized register are set when different errors in various categories occur. The four different categories are:

- *Command Errors*. Set when an unrecognized command or an improperly formed command is received.
- *Execution Errors*. Set when a properly-formed command can not be executed due to conflicting settings or out-of-range data.
- *Device-Dependent Errors*. Set when an overload condition due to improper use or malfunction is detected, or when the error queue has overflowed.
- *Query Errors*. Set when data in the GPIB output queue has been overwritten, or when the GPIB controller has tried to read from the instrument when the output queue was empty

If the corresponding bits in the Event Status Enable Register are enabled, an error will cause the ESB bit in the Status Byte Register to be set. If the corresponding bit in the Service Request Enable Register is set, this will cause the OP1B to issue a service request to the GPIB controller. The GPIB controller would then initiate a serial poll. This technique can be used to monitor errors when using the GPIB.

If an error occurs while the instrument is in the RS232 CTRL mode, an error message will be sent by the OP1B directly to the computer. It will also be logged in the error queue and the Event Status Register, as described above.

If an error occurs while the instrument is in the LOCAL CTRL or LOCAL LOCK modes, an error message will be displayed on the front-panel display. It will also be logged in the error queue and the Event Status Register, as described above.

### 3.2. Error Messages

This is a list of possible error messages, organized by category:

#### 3.2.1. No Errors

"0, No error"

#### 3.2.2. Command Errors

"-100, Command error; Recognized command with improper syntax."

"-102, Syntax error; Unrecognized command."

"-102, Syntax error; Unrecognized command. Multi-channel instruments have synchronous gating only."

"-114, Command error; channel suffix out of range."

"-131, Invalid suffix; Unrecognized units."

### **3.2.3. Execution Errors**

"-200, Execution error; Specific problem unknown."

"-221, Settings conflict; Duty cycle can not be set when triggering externally or manually. Set PW instead."

"-221, Settings conflict; Must be externally triggered for PWin=PWout mode."

"-221, Settings conflict; The double pulse separation is too large. Delay+PW can not exceed 95% of the period."

"-221, Settings conflict; The amplitude+offset sum allowed is too high."

"-221, Settings conflict; The amplitude+offset sum allowed is too low."

"-221, Settings conflict; The pulse delay can not exceed 95% of the period."

"-221, Settings conflict; The pulse width can not exceed the double pulse separation."

"-221, Settings conflict; The pulse width can not exceed the period."

"-221, Settings conflict; This is a valid command in RS232 mode only."

"-222, Data out of range; Negative value not allowed."

"-222, Data out of range; Parameters too high or too low."

"-222, Data out of range; Internal clock frequency is too high"

"-222, Data out of range; Internal clock frequency is too low"

"-222, Data out of range; Pulse width is too high."

"-222, Data out of range; Pulse width is too low."

"-222, Data out of range; The maximum duty cycle limit has been exceeded."

"-222, Data out of range; The delay is too high."

"-222, Data out of range; The delay is too low."

"-222, Data out of range; The amplitude is too high."

"-222, Data out of range; The amplitude is too low."

"-222, Data out of range; The offset is too high."

"-222, Data out of range; The offset is too low."

"-222, Data out of range; Amplitude must be non-zero for calibration."

"-222, Data out of range; Monitor calibration changes in excess of 30% are not allowed."

"-224, Illegal parameter value; Not in list of allowed values."

"-240, Hardware error; this degree of calibration change can not be performed in software; needs hardware changes."

### **3.2.4. Device Dependent Errors**

"1001, Device-specific error; Overload condition detected!"

"1002, Device-specific error; Internal temperature is too high!"

"1003, Device-specific error; DC power supply voltage is too high!"

"1004, Device-specific error; Remove DC power immediately! Incorrect polarity!"

"-350, Queue overflow; The error queue has become too large. Use \*cls or syst:err to clear queue."

### **3.2.5. Query Errors**

"-400, Query error; Data has been lost in the output buffer."

"-400, Query error; There is no data in the output buffer to send."