

AVTECH ELECTROSYSTEMS LTD.

**NANOSECOND WAVEFORM ELECTRONICS
ENGINEERING . MANUFACTURING**

□ P.O. BOX 265
OGDENSBURG
NEW YORK
13669
(315) 472-5270

□ BOX 5120 STN. "F"
OTTAWA, ONTARIO
CANADA K2C 3H4
(613) 226-5772
TELEX 053.4591

INSTRUCTIONS

MODEL AV-106-M-V

S.N. :

WARRANTY

Avtech Electrosystems Ltd. warrants products of its manufacture to be free from defects in material and workmanship under conditions of normal use. If, within one year after delivery to the original owner, and after prepaid return by the original owner, this Avtech product is found to be defective, Avtech shall at its option repair or replace said defective item. This warranty does not apply to units which have been disassembled, modified or subjected to conditions exceeding the applicable specifications or ratings. This warranty is the extent of the obligation or liability assumed by Avtech with respect to this product and no other warranty or guarantee is either expressed or implied.

A.

Test Arrangement and Operating Instructions

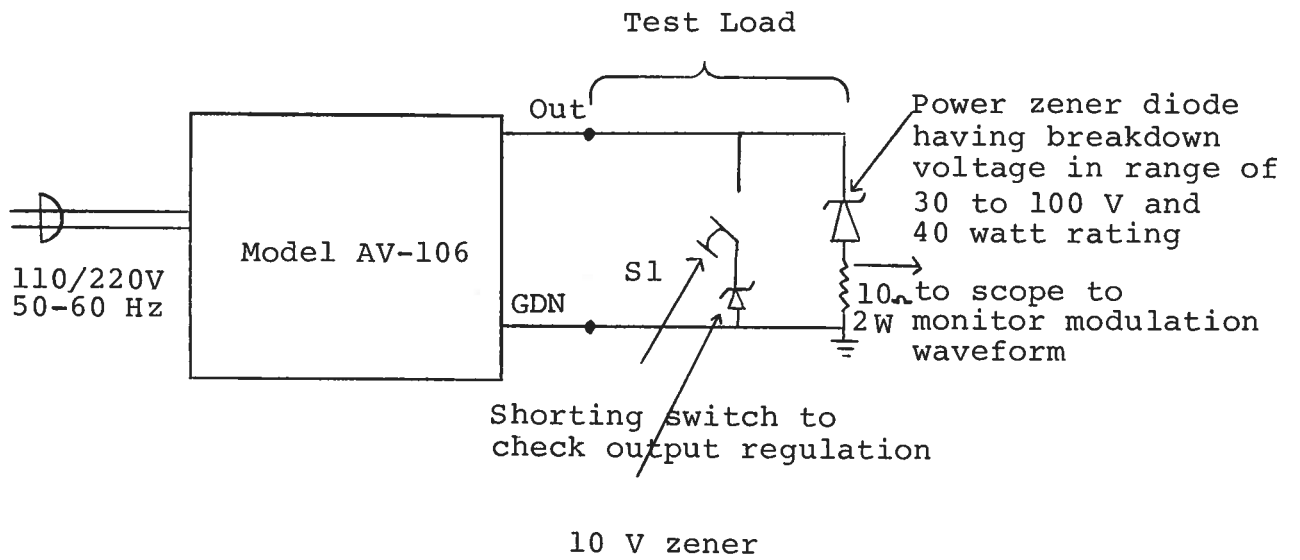

- 1) Set the ON-OFF switch in the OFF position and rotate the front panel pot control to maximum counter clockwise. Connect the test load and shorting switch S, as shown and connect to 50-60 Hz outlet.
- 2) Switch ON-OFF switch to ON position. The meter should read about 5.0 mA. Clockwise rotation of the pot will increase the output current to a maximum of at least 400 mA (for load voltages in the range of 0 to 100 volts).
- 3) With the output current set at any value in the range of 5 to 400 mA, the change in meter reading should be barely detectable when the shorting switch S, is alternately opened and closed ($\Delta I \ll 2.0$ mA). Note that if the 10 V zener is omitted in the shorting arm, then the meter reading will increase by 10 to 15 mA when the shorting switch is closed since with 0 volts output, the modulation module (see system block diagram) ceases to draw a quiescent current of about 15 mA. This additional current therefore flows through the meter.
- 4) If the load is opened circuited or if the load voltage exceeds approximately 100 volts, the ammeter will read 0 mA.
- 5) If the output current can be readily varied over the range of 5 to 400 mA via the pot control and if the output regulation is within specifications, the AV-106 unit can be safely used to bias an IMPATT device.
- 6) Note that while the AV-106 unit is designed to operate into a short circuit load, it should not be operated in this mode for extended periods of time as overheating of the unit may result. Further note that the modulation feature will not operate if the load voltage is less than about five volts.
- 7) To modulate the output current, a signal in the frequency range of 100 Hz to 1.0 MHz is applied to the MOD input port. The input impedance at this point is approximately fifty ohms. The maximum allowable output modulation of 20 mA peak to peak is produced by an input signal of about 200 mV peak to peak (i.e. a modulation sensitivity of approximately 100 mA/V). Note that the output modulation waveform is inverted (i.e. 180°) with respect to the input modulation waveforms (see test waveforms on Proof of Performance Check Sheet).

B.

Circuit Diagram

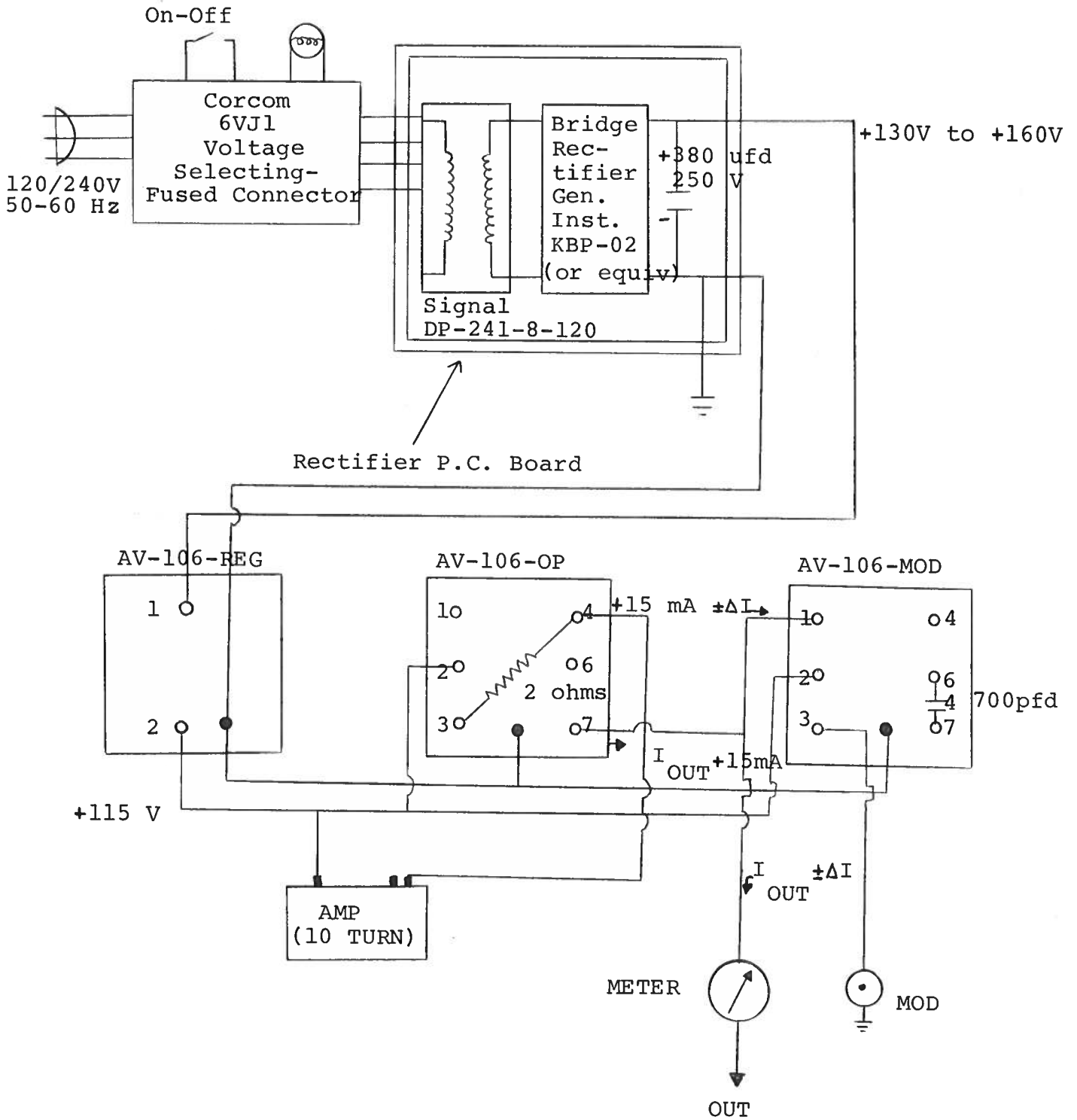

C.

REPAIR PROCEDURE

In the event that the AV-106 unit does not provide an output or is not operating properly as a constant current source, the cause and defective components may be identified as follows:

- 1) Disconnect instrument from 60 Hz source.
- 2) Confirm that fuse is not blown.
- 3) Connect a load similar to that shown under operating instructions. Remove five screws which attach the instrument top panel thereby exposing the instrument interior. **CAUTION:** Points having potentials as high as 160 V are exposed in the interior.
- 4) Connect to a 60 Hz source and set ON-OFF switch to ON position and set front panel pot control to mid-range position. Attach scope probe or voltmeter probe to line connecting positive terminal of rectifier filter capacitor to PIN 1 of AV-106-REG. This voltage should be in the range of +130 to +160 volts. If the voltage is below this range, unsolder the connection to the AV-106-REG module and measure the rectifier output voltage again. If it is still below 130 volts then the rectifier board or transformer is at fault and should be repaired or replaced (see Parts list). If the output voltage is within 130 to 160 volt range then reconnect the AV-106-REG module and check the voltage at PIN 2. This voltage should be about +115 volts. If this voltage is not +115 volts, remove all leads connected to PIN 2 of AV-106-REG and connect a 250 ohm 40 watt load. A voltage of +115 V should then be read. If 115 V is not obtained then the AV-106-REG module must be replaced. If the +115 V was obtained then the AV-106-OP module is probably at fault and should be replaced. The operation of the AV-106-OP voltage to current converter module can be checked by applying a lab power supply providing +115 V (425 mA max.) to PIN 2 of the AV-106-OP module. The module should draw a current approximately 20 mA higher than that registered on the output meter. If the current drawn is outside this range then the AV-106-OP unit is defective and should be replaced. The AV-106-MOD module draws a constant current of about 15 mA from PIN 7 of the AV-106-OP module. With the application of a modulation signal the current drawn by the AV-106-MOD module varies thereby varying the current available to the output load.

D.

PARTS LIST

<u>Part</u>	<u>Manufacturer and Model No.</u>
Power transformer:	Signal Transformer Type 241-8-120
Bridge rectifier:	General Instrument KBPO2 or equivalent
Filter capacitor:	Phillips 380 ufd, 250 V
Printed circuit board:	Avtech Part No. AV-106PCB
Regulator module:	Avtech Part No. AV-106-REG
Voltage to current converter module:	Avtech Part No. AV-106-OP
Modulation module:	Avtech Part No. AV-106-MOD
Ammeter:	Wilbac (Bach-Simpson) Cat No. 108040
Pot:	Bourns 500 ohms Cat. No. 3400S-1-501

Saved in Word as of
October 8/97

File: C:\INSTRUCT\AV-1106MV.DOC

Note: File not adjusted

Part	Manufacturer and Model No.
Power Transformer	Signal Transformer Type 241 B-129
Bridge Rectifier	General Instrument (RVS or equivalent)
Tube Capacitors	Phillips 350 and 250 V
Printed Circuit Board	Wesco Part No. AV-105-CB
Regulator Assembly	Wesco Part No. AV-105-REG
Voltage to Current Converter Module	Wesco Part No. AV-105-DC
Modular Computer	Wesco Part No. AV-105-RM
Monitor	Wides (Bach-Simpson) Part No. 108040
Case	General 300 class Part No. 24003-1-201