



AVTECH ELECTROSYSTEMS LTD.

NANOSECOND WAVEFORM ELECTRONICS
SINCE 1975

P.O. BOX 265
OGDENSBURG, NY
U.S.A. 13669-0265
TEL: (315) 472-5270
FAX: (613) 226-2802

TEL: 1-800-265-6681
FAX: 1-800-561-1970
U.S.A. & CANADA

e-mail: info@avtechpulse.com

BOX 5120 STN. F
OTTAWA, ONTARIO
CANADA K2C 3H4
TEL: (613) 226-5772
FAX: (613) 226-2802

INSTRUCTIONS

MODEL AV-107C-C-M-PN-EA-EW PULSE GENERATOR

S.N. :

WARRANTY

Avtech Electrosystems Ltd. warrants products of its manufacture to be free from defects in material and workmanship under conditions of normal use. If, within one year after delivery to the original owner, and after prepaid return by the original owner, this Avtech product is found to be defective, Avtech shall at its option repair or replace said defective item. This warranty does not apply to units which have been disassembled, modified or subjected to conditions exceeding the applicable specifications or ratings. This warranty is the extent of the obligation or liability assumed by Avtech with respect to this product and no other warranty or guarantee is either expressed or implied.

Fig. 1

PULSE GENERATOR TEST ARRANGEMENT

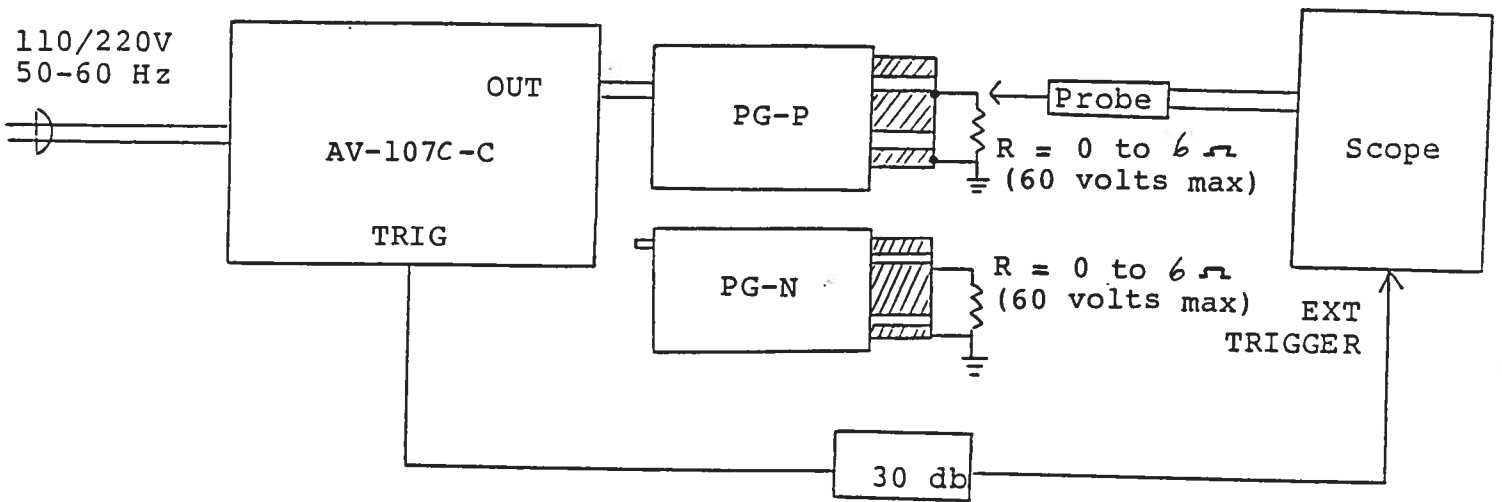

GENERAL OPERATING INSTRUCTIONS

- 1) The equipment should be connected in the general fashion shown above. Since the unit provides an output pulse rise time as low as 20 ns a fast oscilloscope (at least 50 MHz and preferably 200 MHz) should be used to display the waveform. Alternatively, the output current may be monitored using a current probe such as the TEKTRONIX Model CT-2.
- 2) To obtain a POSITIVE output pulse, the front panel polarity switch must be in the POSITIVE position and the -PG-P output module must be connected to the 9 PIN OUT connector on the mainframe. To obtain a NEGATIVE output pulse, the polarity switch must be in the NEGATIVE position and the -PG-N output module must be connected to the 9 PIN OUT connector on the front panel. Note also that the black RG174 50 Ohm cable must be connected to the front panel HV SMA connector.
- 3) The TRIG output channel provides TTL level signals. To avoid overdriving the TRIG input channel of some scopes, a 30 dB attenuator should be placed at the input to the scope trigger channel. The TRIG output precedes the main output when the front panel ADVANCE-DELAY switch is in the ADVANCE position. The TRIG output lags the main output when the switch is in the DELAY position.
- 4) To obtain a stable output display the PRF control on the front panel should be set mid-range. The front panel TRIG toggle switch should be in the INT position. The front panel DELAY control and the scope triggering controls are then adjusted to obtain a stable output. The scope may then be used to set the desired PRF by rotating the PRF control and by the PRF RANGE switch.
- 5) The output pulse widths for the positive and negative outputs are controlled by means of the front panel PW control. To voltage control the output pulse width, set the rear panel switch in the EXT position and apply 0 to +10V to the A BNC connector ($R_{IN} \geq 10K$). (option).

- 6) The output pulse amplitudes for the positive and negative outputs are controlled by means of the front panel AMP control in two ranges, as follows:

0 to 1.0 Amp
0 to 10 Amp

To voltage control the output amplitude, set the rear panel switch in the EXT position and apply 0 to +10V between terminal A and ground ($R_{IN} \geq 10K$). (option).

- 7) An external clock may be used to control the output PRF of the unit by setting the front panel TRIG toggle switch in the EXT position and applying 50 ns (or wider) TTL level pulse to the TRIG BNC connector input.
- 8) The output terminals of the pulse generator module consists of a short length of microstrip transmission line protruding from the module chassis. The OUT terminal is the center conductor which is bounded on both sides by the ground plane (see below):

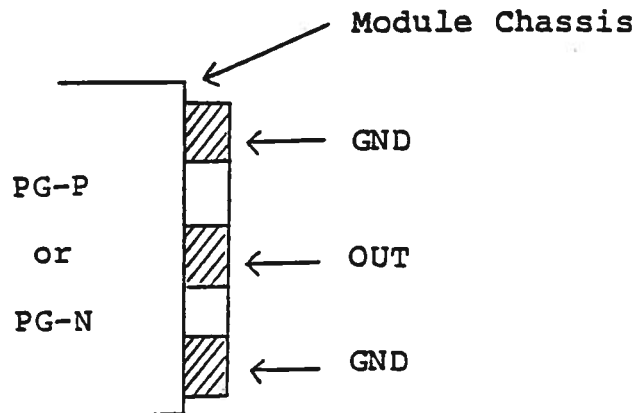

The load should be connected between the OUT and GND terminals using very short leads (≤ 0.5 cm).

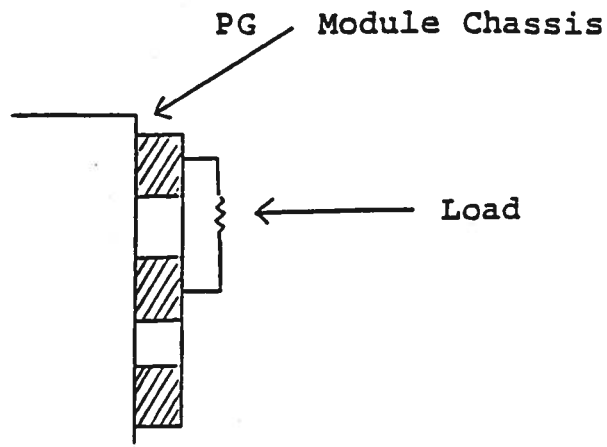

Take care to insure that during soldering the OUT conductor is not shorted to the chassis. Also, use minimal heat when soldering.

- 9) M Option. The SMA output port (M) on the PG-P and PG-N modules provides a replica of the output pulse. The output pulse load current (Amps) and the M output voltage (Volts) are related as follows:

$$I_{LOAD} = 10 V_M \quad (10 \text{ Amp range})$$

$$I_{LOAD} = 0.7 V_M \quad (1.0 \text{ Amp range})$$

For example, for a V_M output of 0.5V, the load current would be 5.0 Amperes. Note that the calibration of the M outputs is valid only when they are terminated into 50 Ohms.

- 10) CAUTION: The AV-107C-C unit is designed to provide 0 to 10 Ampere pulses to a load voltage in the range of 0 to 60 Volts. Insure that the load can dissipate up to 0.60 KW peak power and up to 10 Watts average power (at maximum amplitude and duty cycle).
- 11) OVERLOAD. An automatic overload protective circuit controls the front panel overload light. If the unit is overloaded (by operating at an exceedingly high duty cycle), the protective circuit will turn the output of the instrument OFF and turn the indicator light ON. The light will stay ON (i.e. output OFF) for about 5 seconds after which the instrument will attempt to turn ON (i.e. light OFF) for about 1 second. If the overload condition persists, the instrument will turn OFF again (i.e. light ON) for another 5 seconds. If the overload condition has been removed, the instrument will turn on and resume normal operation. Overload conditions may be removed by:
- 1) Reducing PRF (i.e. switch to a lower range)
 - 2) Reducing pulse width (i.e. switch to a lower range)
 - 3) Reducing the output amplitude (i.e. switch to a lower range)

The overload light may illuminate when the prime power is first applied. The light will extinguish after a few seconds and the unit will then operate normally.

Note that the output stage will safely withstand a short circuited load condition.

12) The unit can be converted from 120 to 240V 50-60 Hz operation by adjusting the voltage selector card in the rear panel fused voltage selector cable connector assembly.

13) For additional assistance:

Tel: (613) 226-5772

Fax: (613) 226-2802

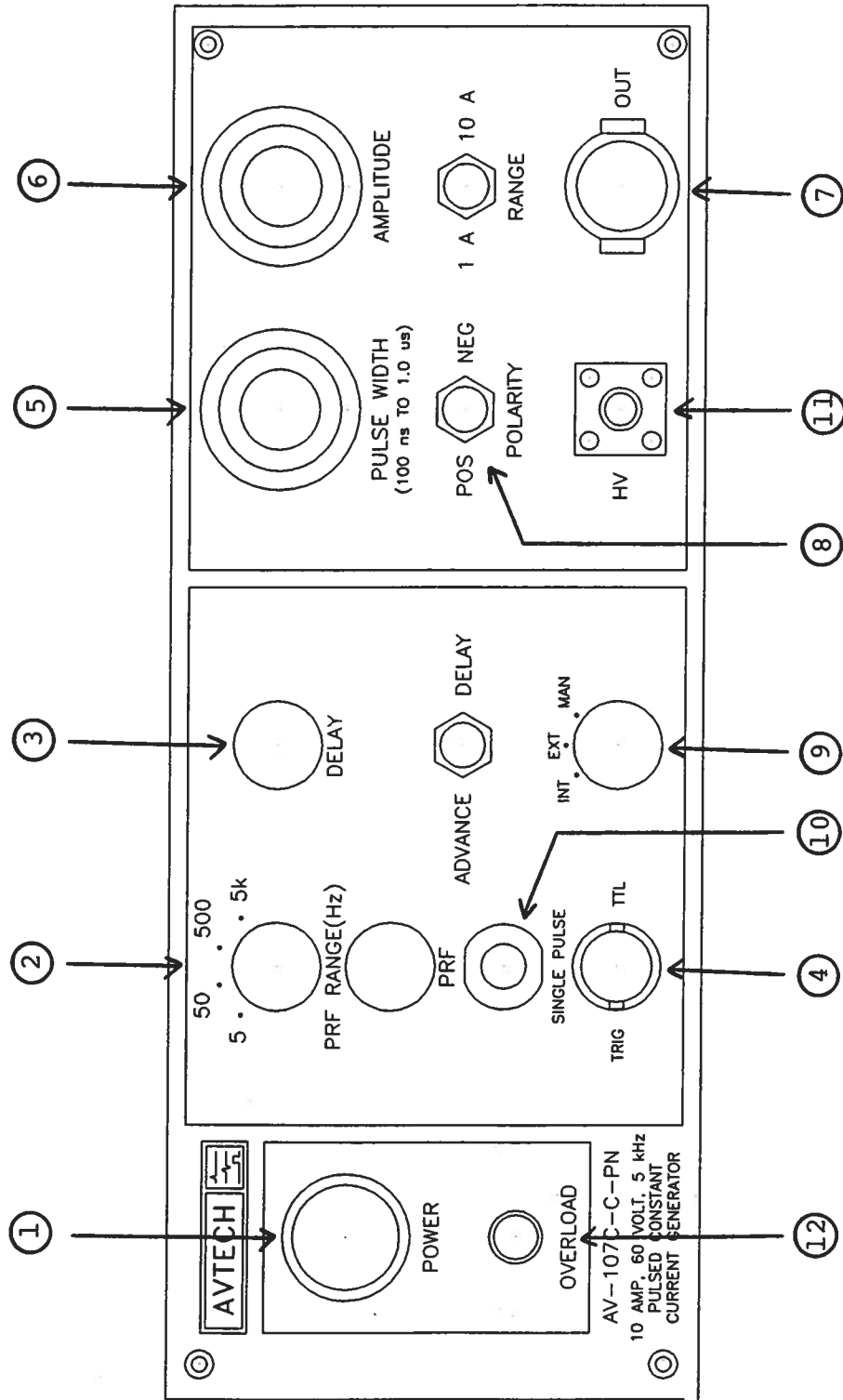

Fig. 2 FRONT PANEL CONTROLS

Fig. 2

(1) ON-OFF Switch. Applies basic prime power to all stages.

(2) PRF Control. Varies PRF from 0.5 Hz to 5 kHz as follows:

Range 1	0.5 Hz	5 Hz
Range 2	5 Hz to	50 Hz
Range 3	50 Hz to	500 Hz
Range 4	500 Hz to	5 kHz

(3) DELAY Control. Controls the relative delay between the reference output pulse provided at the TRIG output (4) and the main output (5). This delay is variable over the range of 0 to about 1.0 us. The TRIG output precedes the main output when the ADVANCE-DELAY switch is in the ADVANCE position and lags when the switch is in the DELAY position.

(4) TRIG Output. This output precedes the main output and is used to trigger the scope time base. The output is a TTL level 100 ns (approx.) pulse capable of driving a fifty Ohm load. The external trigger signal is applied at this input when the EXT toggle switch is in the EXT position. The output pulse appears about 100 ns after the application of the TRIG pulse.

(5) PW Control (P and N). Ten turn control which varies the output pulse width from 50 ns to 1.0 us.

(6) AMP Control (P and N). The output pulse amplitude is controlled by means of the ten turn potentiometer and the two-position range switch as follows:

0 to 1.0 Amp
0 to 10 Amp

(7) OUT Connector. A multi pin connector which attaches the 2 foot cable from the pulse generator modules (AV-107C-M-PG-P and AV-107C-M-PG-N) to the mainframe.

CAUTION: To operate the polarity of the output module (P or N) must correspond to the setting of the polarity switch (P or N).

(8) POLARITY. To obtain a POSITIVE output pulse, the front panel polarity switch must be in the POSITIVE position and the -PG-P output module must be connected to the 9 PIN OUT connector on the mainframe. To obtain a NEGATIVE output pulse, the polarity switch must be in the NEGATIVE position and the -PG-N output module must be connected to the 9 PIN OUT connector on the front panel.

- (9) EXT-INT-MAN Control, SINGLE PULSE. With this toggle switch in the INT position, the PRF of the unit is controlled via an internal clock which in turn is controlled by the PRF controls. With the toggle switch in the EXT position, the unit requires a 50 ns (or wider) TTL level pulse applied at the TRIG input in order to trigger the output stages. To obtain a single pulse out, set this switch in the "MAN" position and push the single pulse button.
- (10) HV Connector. The black RG174 coaxial cable from the output module must be connected to this SMA connector.
- (11) OVERLOAD. An automatic overload protective circuit controls the front panel overload light. If the unit is overloaded (by operating at an exceedingly high duty cycle), the protective circuit will turn the output of the instrument OFF and turn the indicator light ON. The light will stay ON (i.e. output OFF) for about 5 seconds after which the instrument will attempt to turn ON (i.e. light OFF) for about 1 second. If the overload condition persists, the instrument will turn OFF again (i.e. light ON) for another 5 seconds. If the overload condition has been removed, the instrument will turn on and resume normal operation. Overload conditions may be removed by:
- 1) Reducing PRF (i.e. switch to a lower range)
 - 2) Reducing pulse width (i.e. switch to a lower range)
 - 3) Reducing the output amplitude (i.e. switch to a lower range)

The overload light may illuminate when the prime power is first applied. The light will extinguish after a few seconds and the unit will then operate normally.

Note that the output stage will safely withstand a short circuited load condition.

Fig. 3

BACK PANEL CONTROLS

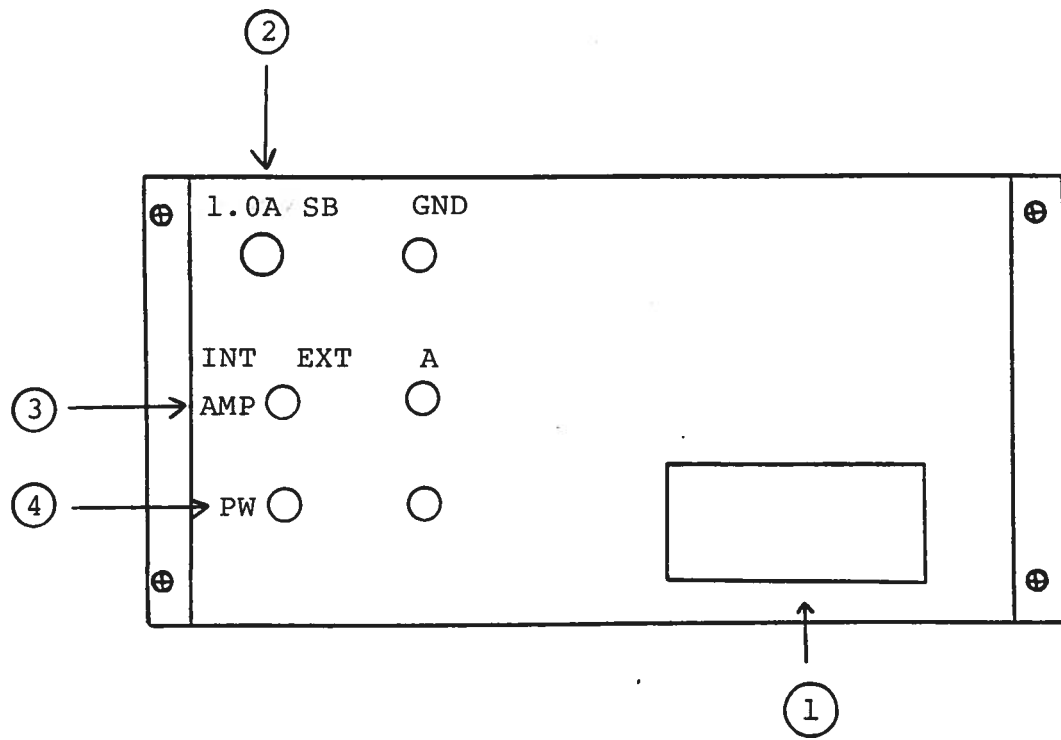

- (1) FUSED CONNECTOR, VOLTAGE SELECTOR. The detachable power cord is connected at this point. In addition, the removable cord is adjusted to select the desired input operating voltage. The unit also contains the main power fuse (0.5 A SB).
- (2) 1.0A SB. Fuse which protects the output stage if the output duty cycle rating is exceeded.
- (3) EA. To voltage control the output amplitude, set the switch in the EXT position and apply 0 to +10 Volts to the A BNC connector ($R_{IN} \geq 10K$). (option).
- (4) EW. To voltage control the output pulse width, set the switch in the EXT position and apply 0 to +10 Volts to the A BNC connector ($R_{IN} \geq 10K$). (option).

SYSTEM DESCRIPTION AND REPAIR PROCEDURE

The AV-107C-C-PN unit consists of the following basic modules:

- 1) AV-107C-M-PG pulse generator modules (positive and negative)
- 2) AV-107C-CL clock module
- 3) +24V power supply board
- 4) $\pm 100V$ power supply module
- 5) -OL-471 overload module

The modules are interconnected as shown in Fig. 4.

In the event of an instrument malfunction, it is most likely that the 1.0A slow blow fuse or the main power fuse on the rear panel has failed. Replace if necessary. If the unit still does not function, it is most likely that some of the output switching elements (SL7T) may have failed due to an output short circuit condition or to a high duty cycle condition. The switching elements may be accessed by removing the cover plate on the bottom side of the -PG module. The cover plate is removed by removing the four counter sunk 6-32 Phillips screws. NOTE: First turn off the prime power. CAUTION: Briefly ground the SL7T tabs to discharge the 100 Volts power supply potential. The elements may be removed from their sockets by means of a needle nosed pliers after removing the four counter sunk 2-56 Phillips screws which attach the small aluminum heat sinks to the body of the AV-107-PG module. The SL7T is a selected VMOS power transistor in a TO 220 package and may be checked on a curve tracer. If defective, replacement units should be ordered directly from Avtech. When replacing the SL7T switching elements, take care to insure that the short lead (of the three leads) is adjacent to the back of the chassis. (See following Fig.). The SL7T elements are electrically isolated from the small aluminum heat sinks but are bonded to the heat sinks using WAKEFIELD TYPE 155 HEAT SINK ADHESIVE. If the switching elements are not defective, then the four Phillips screws on the back panel should be removed. The top cover may then be slid off and the operation of the clock and power supply modules checked. The clock module is functioning properly if:

- a) 0.1 us TTL level outputs are observed at pins 2 and 3.
- b) The PRF of the outputs can be varied over the range of 0.5 Hz to 5.0 kHz using the PRF controls.
- c) The relative delay between the pin 2 and 3 outputs can be varied by at least 1 us by the DELAY control.

The sealed clock module must be returned to Avtech for repair or replacement if the above conditions are not observed.

PC-107C - PG. SL7T HEAT SINKING

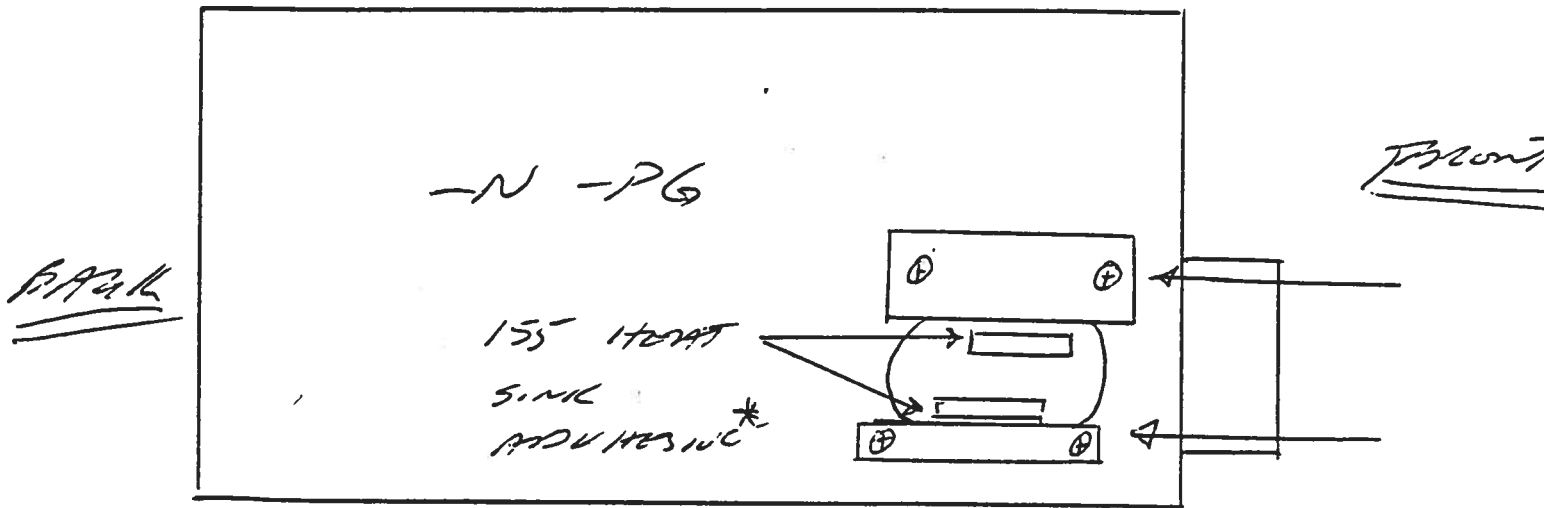
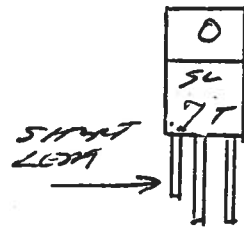
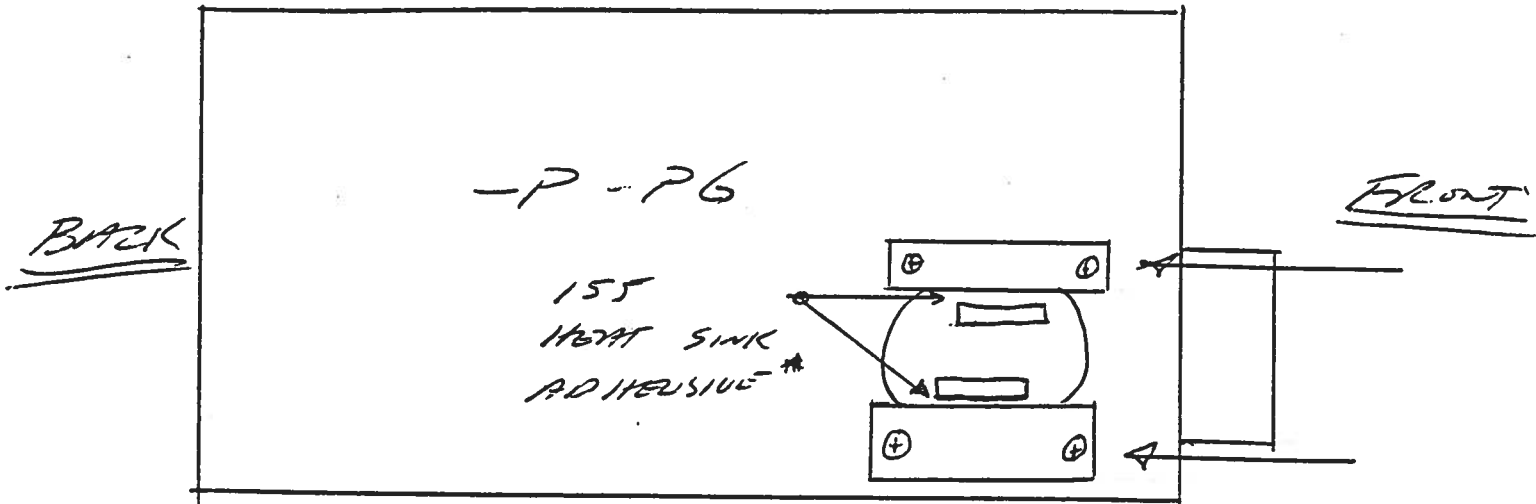

*
CAUTION INSURE THAT
TABS OF SLIT
DO NOT CONTACT
H.S. TABS.

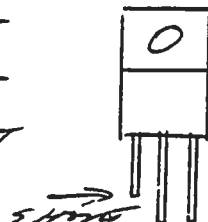

March 24/97

Disk: AV-107C, D, E

Name: 7CCMPNEA.INS