



AVTECH ELECTROSYSTEMS LTD.

NANOSECOND WAVEFORM ELECTRONICS
SINCE 1975

P.O. BOX 265
OGDENSBURG, NY
U.S.A. 13669-0265
TEL: (315) 472-5270
FAX: (613) 226-2802

TEL: 1-800-265-6681
FAX: 1-800-561-1970
U.S.A. & CANADA

BOX 5120 STN. F
OTTAWA, ONTARIO
CANADA K2C 3H4
TEL: (613) 226-5772
FAX: (613) 226-2802

INSTRUCTIONS

MODEL AV-107C-PS-P-UTA2 PULSE GENERATOR

S.N. :

WARRANTY

Avtech Electrosystems Ltd. warrants products of its manufacture to be free from defects in material and workmanship under conditions of normal use. If, within one year after delivery to the original owner, and after prepaid return by the original owner, this Avtech product is found to be defective, Avtech shall at its option repair or replace said defective item. This warranty does not apply to units which have been disassembled, modified or subjected to conditions exceeding the applicable specifications or ratings. This warranty is the extent of the obligation or liability assumed by Avtech with respect to this product and no other warranty or guarantee is either expressed or implied.

Fig. 1

PULSE GENERATOR TEST ARRANGEMENT

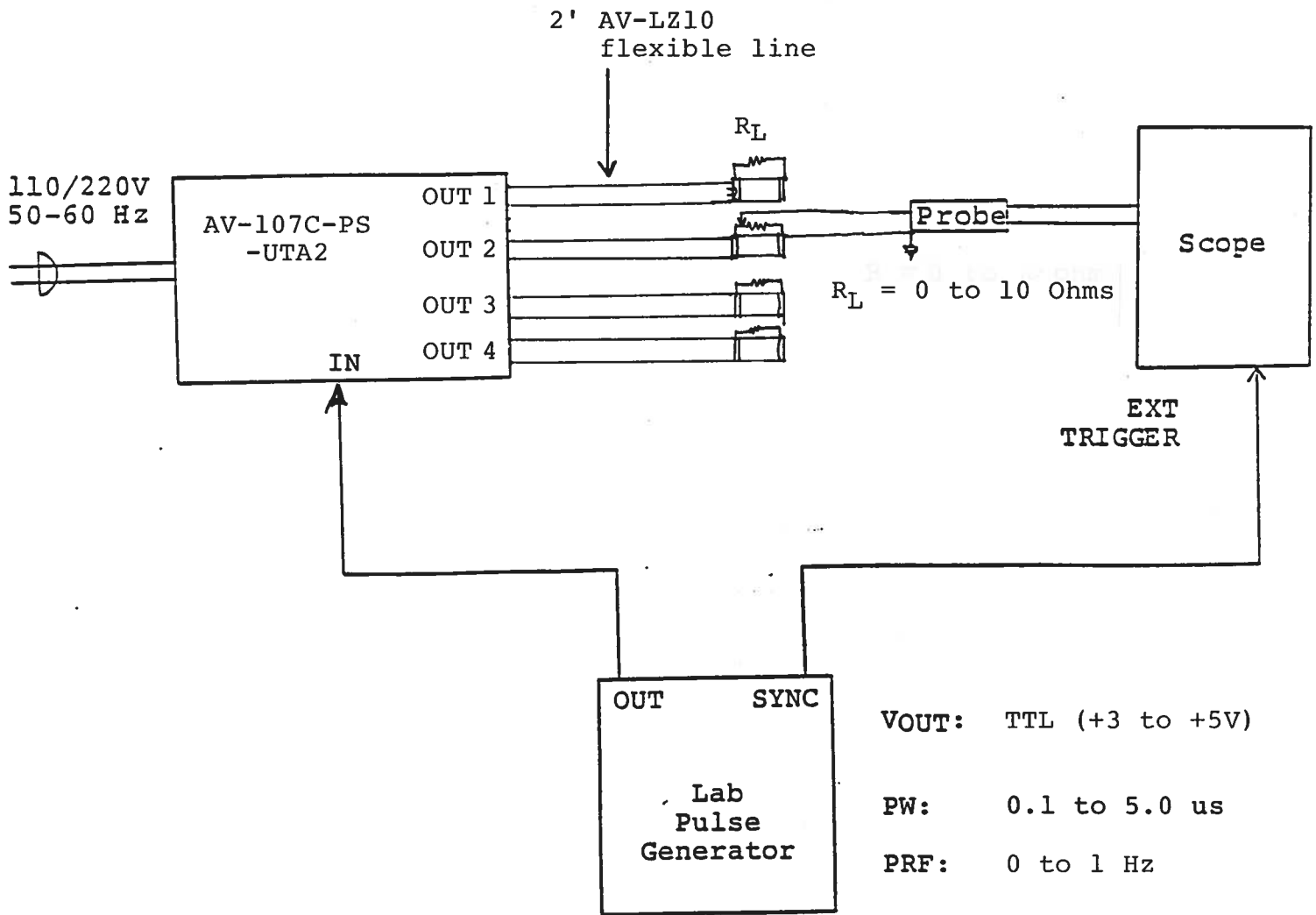

GENERAL OPERATING INSTRUCTIONS

- 1) The equipment should be connected in the general fashion shown above. Since the unit provides an output pulse rise time as low as 50 ns a fast oscilloscope (at least 50 MHz and preferably 200 MHz) should be used to display the waveform. The load current may be deduced if the resistance and load voltage are known. Alternatively, the output current may be monitored using a current probe.
- 2) The output terminals of the pulse generator consists of a 24" length of 10 Ohm microstrip transmission line protruding from the front panel. The flexible line is terminated in a 0.5" x 0.5" x 1/16" PCB board to which the load may be soldered.

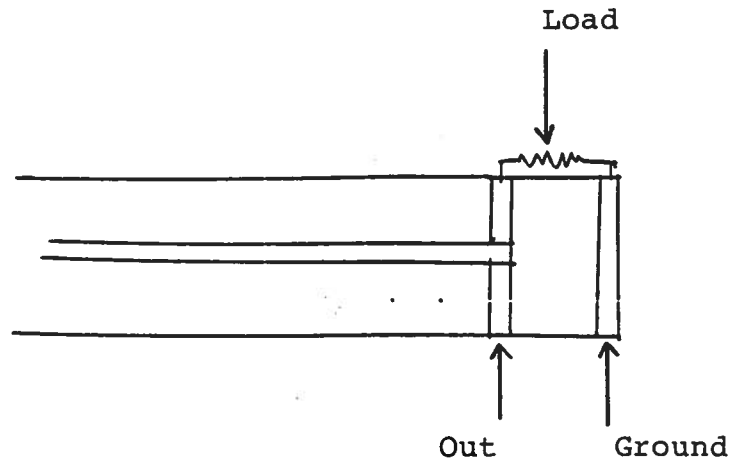

Note that for ideal operation, the load should be 10 Ohms.

The load should be connected between the OUT and GND terminals using very short leads (≤ 0.5 cm). Longer leads introduce inductance which will result in spikes and overshoot on the leading and falling edge of the load voltage waveform. When driving non-linear or unknown loads, increase the amplitude slowly to insure that the terminal voltage does not exceed 100 Volts. If the terminal voltage exceeds 100 Volts the unit may cease to function as a constant current source. Note also that if only one channel is used, the PRF may be increased to as much as 50 Hz. The basic timing waveforms should resemble the following:

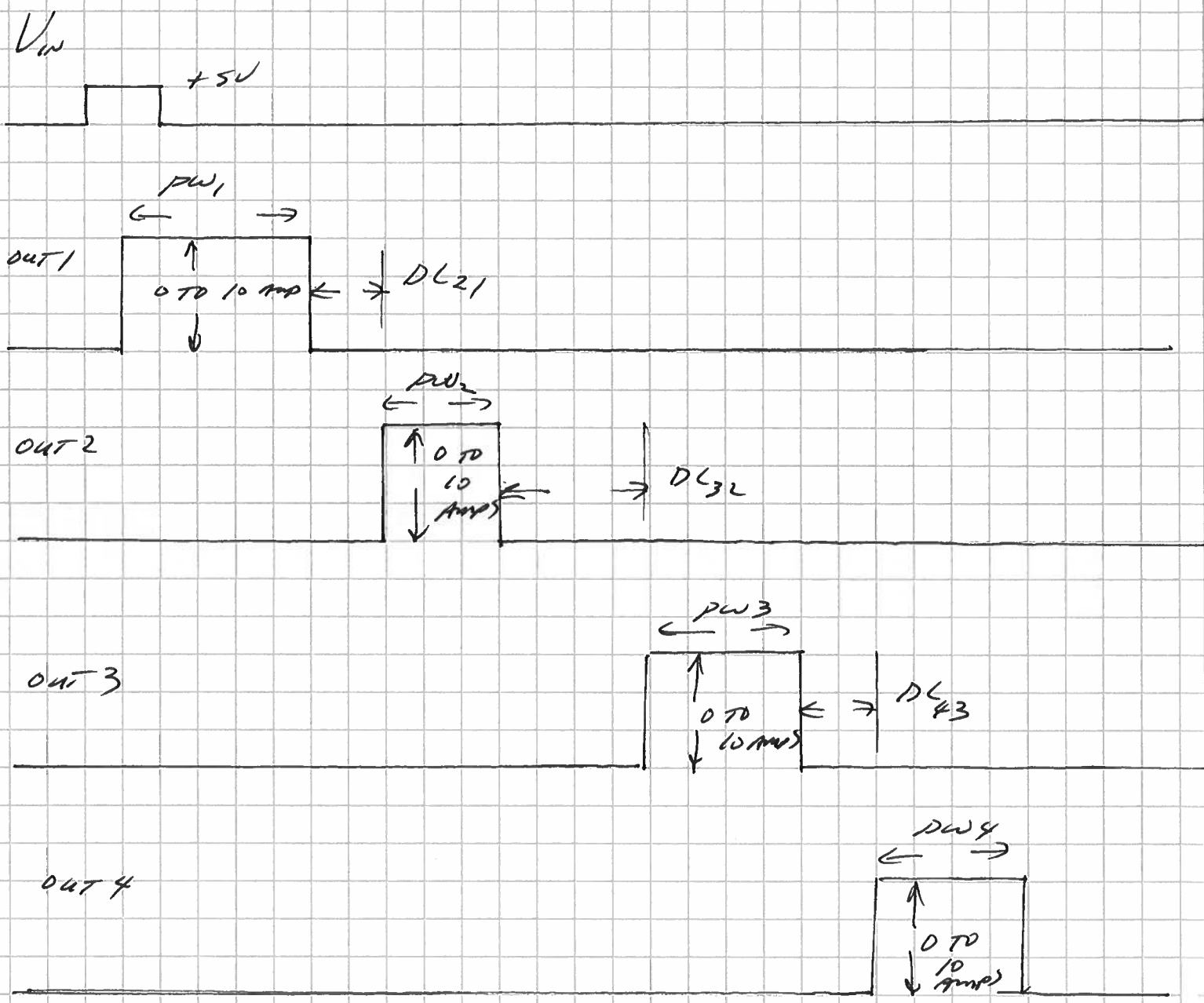

BASIC OUTPUT WAVEFORMS

- 3) CAUTION: The AV-107C unit is designed to provide 0 to 10 Ampere pulses to a load voltage in the range of 0 to 100 Volts. Insure that the load can dissipate up to 1.0 KW peak power.
- 4) For pulse mode operation the front panel mode switch should be placed in the PULSE position and a TTL trigger pulse applied to IN terminal. If the switch is placed in the DC position, the channels output a constant current of 50 mA DC to the load. If the switch is placed in the SP position, the channels will output a single pulse for each push of the SINGLE PULSE button.
- 5) The output pulse width for each channel is controlled by the related ten turn pulse width control.
- 6) The output amplitude for each channel is controlled by the related one turn amplitude control.
- 7) The relative delay between the channel outputs are controlled by the related ten turn delay controls.
- 8) CAUTION: The output stage is protected against overload condition by a 1.0 A slow blow fuse on the main frame back panel. However, the output switching elements (SL12T) may fail if the unit is triggered at a PRF exceeding 1 Hz. Heating and subsequent likely failure of the output stage is reduced if the following action is taken where possible:
 - a) PRF is kept to a minimum.
 - b) Keep the output PW to a minimum.
 - c) Keep the output voltage as near to 100 Volts as possible by adding series resistance to diode type loads to increase the effective output voltage.
- 9) AV-107 units with a serial number higher than 5600 are protected by an automatic overload protective circuit which controls the front panel overload light. If the unit is overloaded (by operating at an exceedingly high duty cycle or by operating into a short circuit), the protective circuit will turn the output of the instrument OFF and turn the indicator light ON. The light will stay ON (i.e. output OFF) for about 5 seconds after which the instrument will attempt to turn ON (i.e. light OFF) for about 1 second. If the overload condition persists, the instrument will turn OFF again (i.e. light ON) for another 5 seconds. If the overload condition has been removed, the instrument will turn on and resume normal operation. Overload conditions may be removed by:

- 1) Reducing PRF (i.e. switch to a lower range)
 - 2) Reducing pulse width (i.e. switch to a lower range)
- 10) The unit can be converted from 110 to 220V 50-60 Hz operation by adjusting the voltage selector card in the rear panel fused voltage selector cable connector assembly.
- 11) For additional assistance:

Tel: (613) 226-5772

Fax: (613) 226-2802

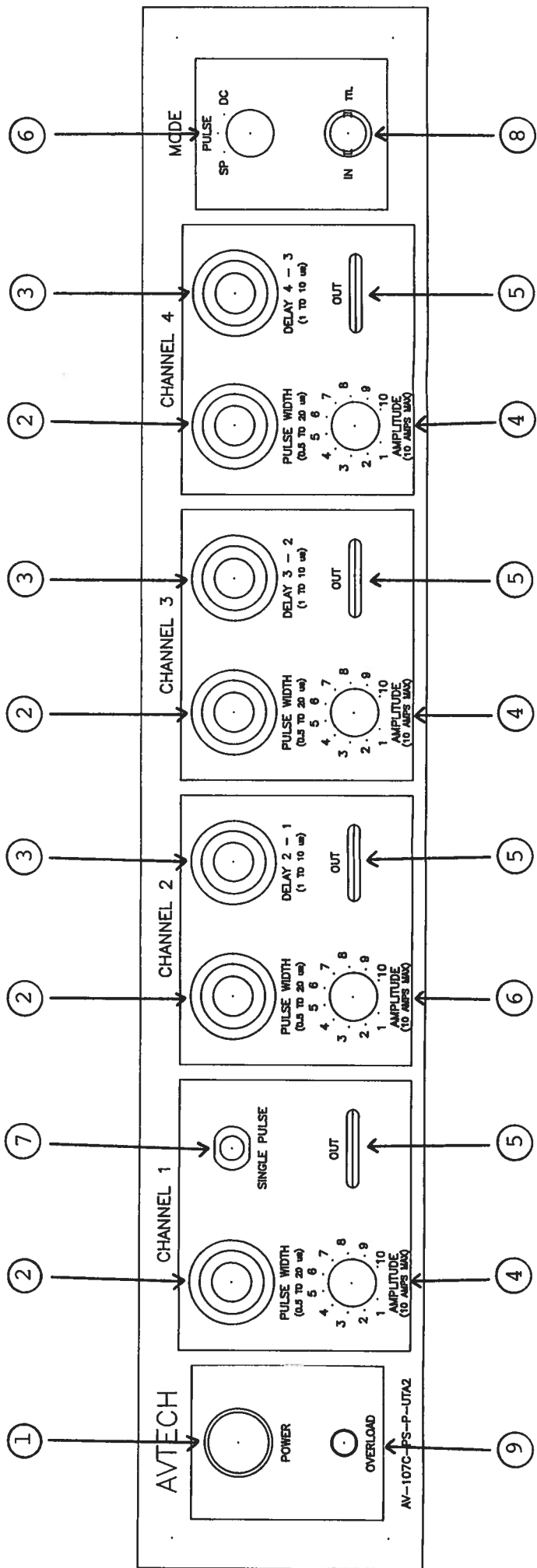
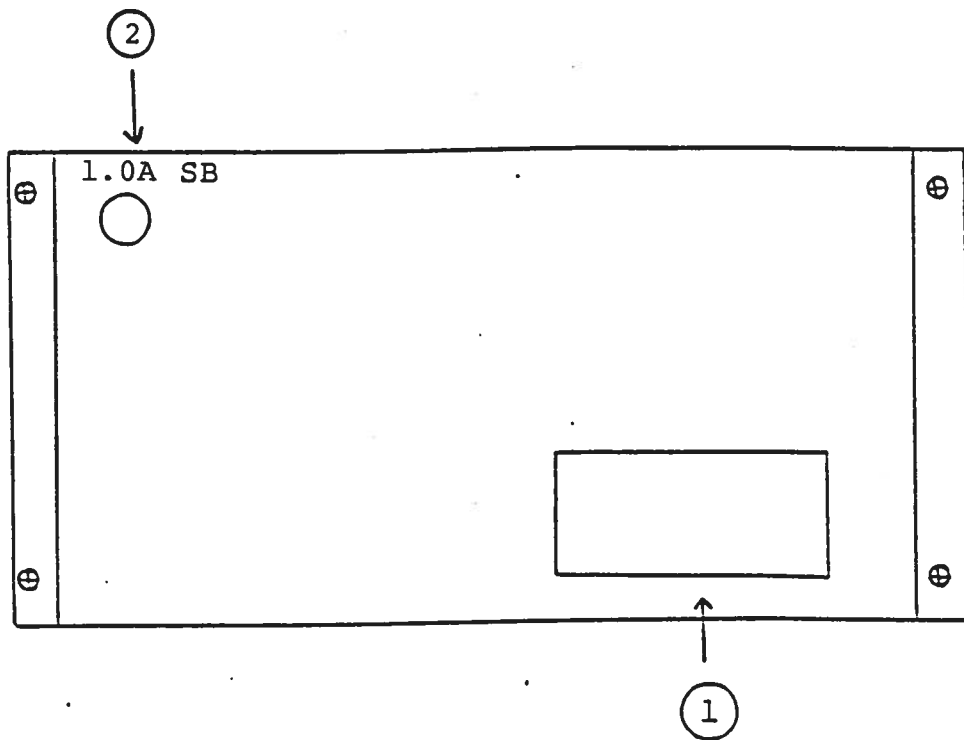

Fig. 2 FRONT PANEL CONTROLS

- (1) ON-OFF Switch. Applies basic prime power to all stages.
- (2) PULSE WIDTH. One ten turn control per channel for adjusting the output pulse width from 0.5 to 20 us.
- (3) DELAY. One ten turn control for Channels 2, 3 and 4 for controlling the delay (1 to 10 us) with respect to the preceding channel.
- (4) AMPLITUDE. A one turn control (for each channel) for varying the output amplitude from 0 to +10 Amperes (to $R_L = 0$ to 10 Ohms).
- (5) OUT. Ten Ohm flexible microstrip output line terminated in a 0.5" x 0.5" x 1/16" circuit board. The load is solder connected to the PCB board. Ideally the load should be 10 Ohms with a very low inductance component.
- (6) MODE SP POSITION: A single pulse out from each channel for each push of the single pulse button.
 PULSE POSITION: A single pulse out from each channel for each TTL input at the IN terminal.
 DC: A constant 50 mA DC out from each channel.
- (7) SINGLE PULSE. See 6), SP position.
- (8) IN. BNC connector to which TTL pulse (PW 0.1 to 5.0 us) is applied for PULSE mode operation.
- (9) OVERLOAD. AV-107 units with a serial number higher than 5600 are protected by an automatic overload protective circuit which controls the front panel overload light. If the unit is overloaded (by operating at an exceedingly high duty cycle or by operating into a short circuit), the protective circuit will turn the output of the instrument OFF and turn the indicator light ON. The light will stay ON (i.e. output OFF) for about 5 seconds after which the instrument will attempt to turn ON (i.e. light OFF) for about 1 second. If the overload condition persists, the instrument will turn OFF again (i.e. light ON) for another 5 seconds. If the overload condition has been removed, the instrument will turn on and resume normal operation. Overload conditions may be removed by:
 - 1) Reducing PRF
 - 2) Reducing pulse width

Fig. 3

BACK PANEL CONTROLS



- (1) FUSED CONNECTOR, VOLTAGE SELECTOR. The detachable power cord is connected at this point. In addition, the removable cord is adjusted to select the desired input operating voltage. The unit also contains the main power fuse (0.50A SB).
- (2) 1.0 A SB. Fuse which protects the output stage if the output duty cycle rating is exceeded.

SYSTEM DESCRIPTION AND REPAIR PROCEDURE

The AV-107C-PS unit consists of the following basic modules:

- 1) AV-107C-PG pulse generator module (four)
- 2) +24V power supply board
- 3) -PS-EA power supply-amplitude module
- 4) -PW-DL pulse width, delay control module
- 5) -OL overload module

The modules are interconnected as shown in Fig. 4.

In the event of an instrument malfunction, it is most likely that the 1.0 A slow blow fuse or the main power fuse on the rear panel has blown. Replace if necessary. If the unit still does not function, it is most likely that some of the output switching elements SL15AT may have failed due to an output short circuit condition or to a high duty cycle condition. The switching elements may be accessed by removing the four cover plates on the bottom side of the instrument. NOTE: First turn off the prime power.

CAUTION: Briefly ground the SL15AT tabs to discharge the 100 Volts power supply potential. The elements may be removed from their sockets by means of a needle nosed pliers. The SL15AT is a selected VMOS power transistor in a TO 220 package and may be checked on a curve tracer. If defective, replacement units should be ordered directly from Avtech. When replacing the SL15AT switching elements, take care to insure that the short lead (of the three leads) is adjacent to the back of the chassis.

AVTECH**AVTECH ELECTROSYSTEMS LTD.**NANOSECOND WAVEFORM ELECTRONICS
SINCE 1975

P.O. BOX 265
OGDENSBURG, NY
U.S.A. 13669-0265
TEL: (315) 472-5270
FAX: (613) 226-2802

TEL: 1-800-265-6681
FAX: 1-800-561-1970
U.S.A. & CANADA

BOX 5120 STN. F
OTTAWA, ONTARIO
CANADA K2C 3H4
TEL: (613) 226-5772
FAX: (613) 226-2802

September 22, 1994.

Tel: 814-273-2603

Fax: 814-794-5010

Dr. Frank Lu
The University of Texas at Arlington
P.O. Box 19018
Arlington, TX 76019

Dear Frank:

Following our recent phone conversation, I am pleased to provide the following revised price and delivery quotation:

Model designation: AV-107C-PS-P-UTA2

Number of channels: 4

Output amplitude: 0 to +10 Amperes.
One single turn amplitude control per channel. A ten Ohm resistor will be used as the factory test load.

Load voltage range: 0 to +100 Volts.

Pulse width: 0.5 to 20 us.
One ten turn locking dial control per channel.

Rise, fall time: ≤ 50 ns.

Channel delay: 3 ten turn locking dial controls provided to vary delays of channel 2 with respect to channel 1, channel 3 with respect to channel 2 and channel 4 with respect to channel 3 (1 to 10 us).

Input trigger: TTL, PW ≥ 100 ns.

PRF: ≤ 1 Hz. (Controlled by PRF of input TTL pulse). Push button provided for single pulse operation.

DC mode: Two position switch disables pulse output and provides a 50 mA constant current to each output (V_{out} max 5 Volts).

Chassis size: 3.9" x 17" x 14.8".

Connectors: In: BNC
Out: Each channel provided with a 10 Ohm flexible microstrip output line 24" long. (Model AV-LZ10, see pages 6 and 7 Cat. 8S2). Solder connect load to end of each line.

Prime power: 120/240V, 50-60 Hz.

Other: See AV-107-C series, pages 76 and 77, Cat. No. 8. Note that this special unit comprises only a mainframe without any output module.

Price: \$5,490.00 US each, FOB destination.

Delivery: 45 days.

Thank you for your interest in our products. Please contact me again if you require any additional information.

Yours truly,

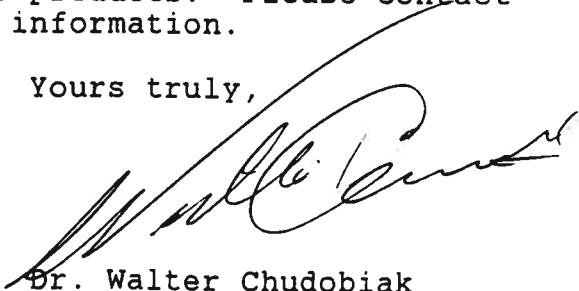

Dr. Walter Chudobiak
Chief Engineer

WC:dh

PULSE GENERATOR
PERFORMANCE CHECK

Model: *11V-107C-PS-P-UTAZ*

S.N.: *7141*

Date: *DEC 7 1994*

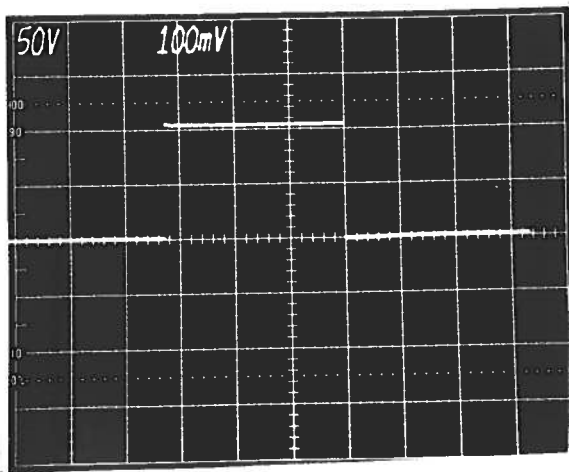

- a) Output signal amplitude:
PULSE: 0 TO +10 AMPS
- b) Pulse width:
DC: 50 mA
0.5 TO 20 μ S
- c) Rise time:
 ≤ 50 NS
- d) Fall time:
 ≤ 50 NS
- e) PRF: *0 TO 1 KHz*

f) Jitter, stability:
OK

g) Prime power:
120/240 V
50-60 Hz

50 VOLTS/DIV, 5 μ S/DIV
PRF = 50 KHz, $R_L = 10 \Omega$

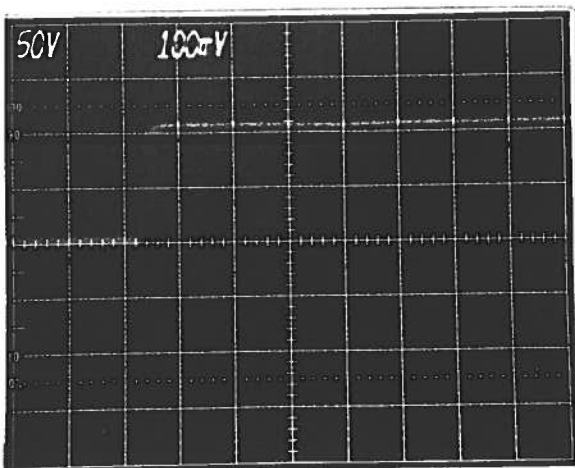

- h) DELAY: *2-1 1 to 20 μ S*
3-2 1 TO 20 μ S
4-3 1 TO 20 μ S

A

50 VOLTS/DIV, 0.2 μ S/DIV
PRF = 50 KHz, $R_L = 10 \Omega$