

AVTECH ELECTROSYSTEMS LTD.

NANOSECOND WAVEFORM ELECTRONICS
ENGINEERING - MANUFACTURING

□ P.O. BOX 265
OGDENSBURG
NEW YORK
13669
(315) 472-5270

☒ BOX 5120, STN. "F"
OTTAWA, ONTARIO
CANADA K2C 3H4
TEL: (613) 226-5772
FAX: (613) 226-2802

INSTRUCTIONS

MODEL AV-107E-C-P-FCB PULSE GENERATOR

S.N.: 5675 (MODIFIED)

WARRANTY

Avtech Electrosystems Ltd. warrants products of its manufacture to be free from defects in material and workmanship under conditions of normal use. If, within one year after delivery to the original owner, and after prepaid return by the original owner, this Avtech product is found to be defective, Avtech shall at its option repair or replace said defective item. This warranty does not apply to units which have been disassembled, modified or subjected to conditions exceeding the applicable specifications or ratings. This warranty is the extent of the obligation or liability assumed by Avtech with respect to this product and no other warranty or guarantee is either expressed or implied.

Fig. 1A

RECOMMENDED OPERATING PROCEDURE

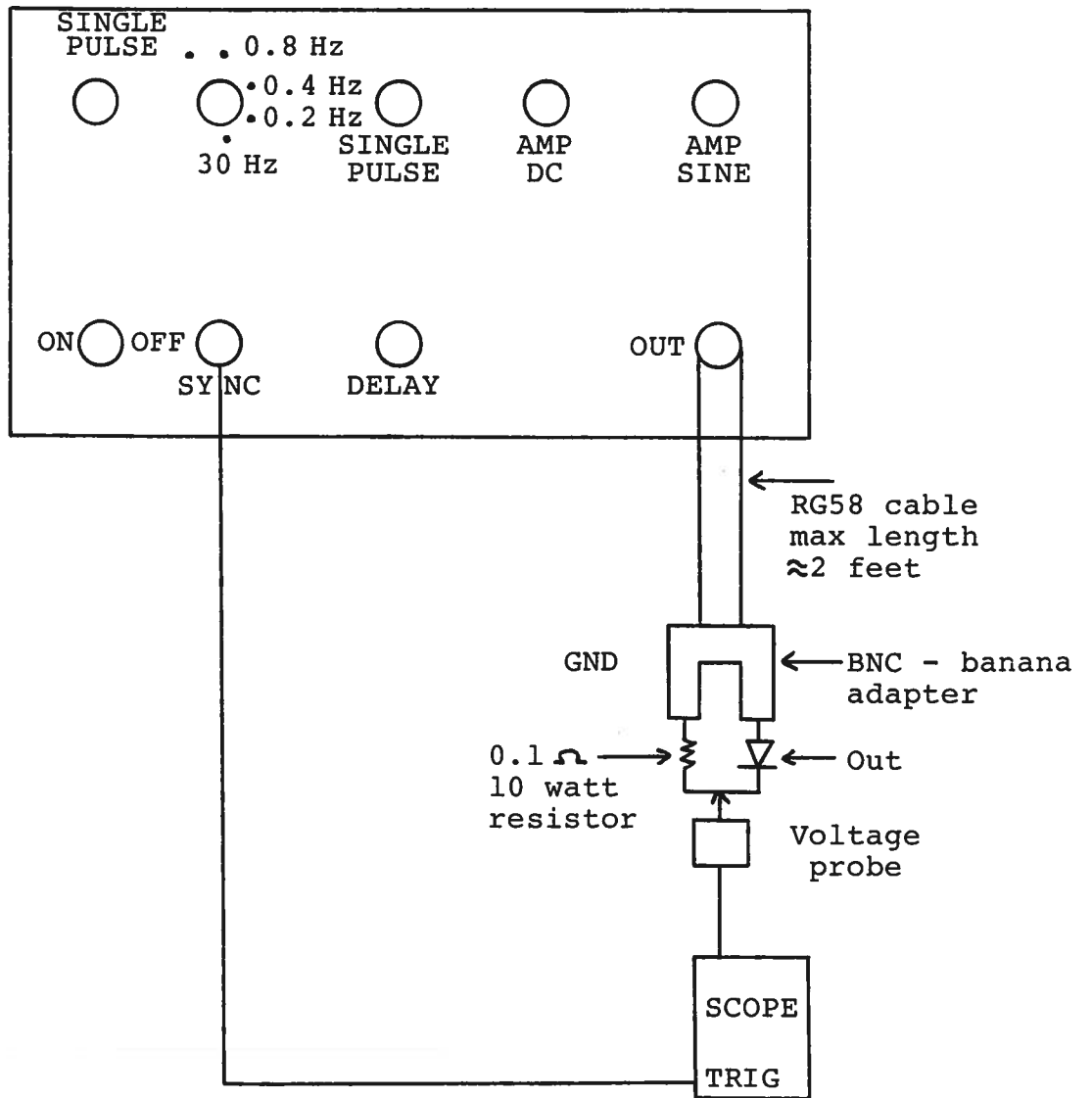

Notes:

- 1) Set AMP DC and AMP SINE controls both maximum CCW.
- 2) Set rear panel DC ON-OFF switch on ON position.
- 3) Connect diode to be tested in series with 0.1 ohm 10 watt resistor. Monitor voltage across resistor to deduce diode current. Five volts resistor voltage corresponds to 50 amps diode current (i.e. $I_{\text{DIODE}} = 10 V_R$). Alternatively, a current probe may be used in which case the 0.1 resistor may be omitted.
- 4) If coaxial cable such as RG58 is used to connect the diode jig to the AV-107E mainframe, the cable length should not exceed about two feet. If a longer cable is required, then number 12 (or heavier) hook up wire should be used.
- 5) Set AV-107E-C control switch in the 0.8 Hz position and connect the AV-107E-C SYNC output to the scope TRIGGER input. Set the AV-107E-C delay control mid range and set the scope on + EXT trig mode and time base on 5 ms/div. Set scope vertical on 1 volt/div (i.e. 10 amp/div).
- 6) Apply prime power to AV-107E-C (note that unit was shipped with rear panel voltage selector card in 240 volt position).
- 7) Adjust scope triggering controls to insure that scope is triggering.
- 8) For a diode DC current of 1.0 ampere, set the DC AMP control on 9.9 (see Fig. 2).
- 9) For a diode peak sinusoid current of 30 amperes, set the SINE AMP control on 6.0 (see Fig. 3). A zero to peak amplitude of 3 volts should be observed on the scope.
- 10) For single pulse operation, set the AV-107E-C selector switch on the single pulse position and push the single pulse button for each output pulse.
- 11) The selector switch may also be set in the 0.44 Hz, 0.22 Hz or 30 Hz position. However, when set in the 30 Hz position, the unit operates at a PRF of about 30 Hz and so the AMP sine setting should not be set higher than 4.0 or the output stage may be overloaded (and the diode may be damaged). The calibration curve given in Fig. 3 is not valid when the selector switch is set in the 30 Hz position.

- 12) Note that the AMP DC control varies the output DC current over the range of 100 mA to 1.05 amperes. If a DC current of 0 is required, the rear panel ON-OFF switch may be set in the OFF position.
- 13) The output pulse width may drift slightly during the first few minutes of running time. The output pulse width will stabilize at 8.3 ms after a warm-up time of 15 minutes.
- 14) If additional information or assistance is required:

Telephone: (613) 226-5772
Fax: (613) 226-2802

Fig. 1B

FRONT PANEL CONTROLS

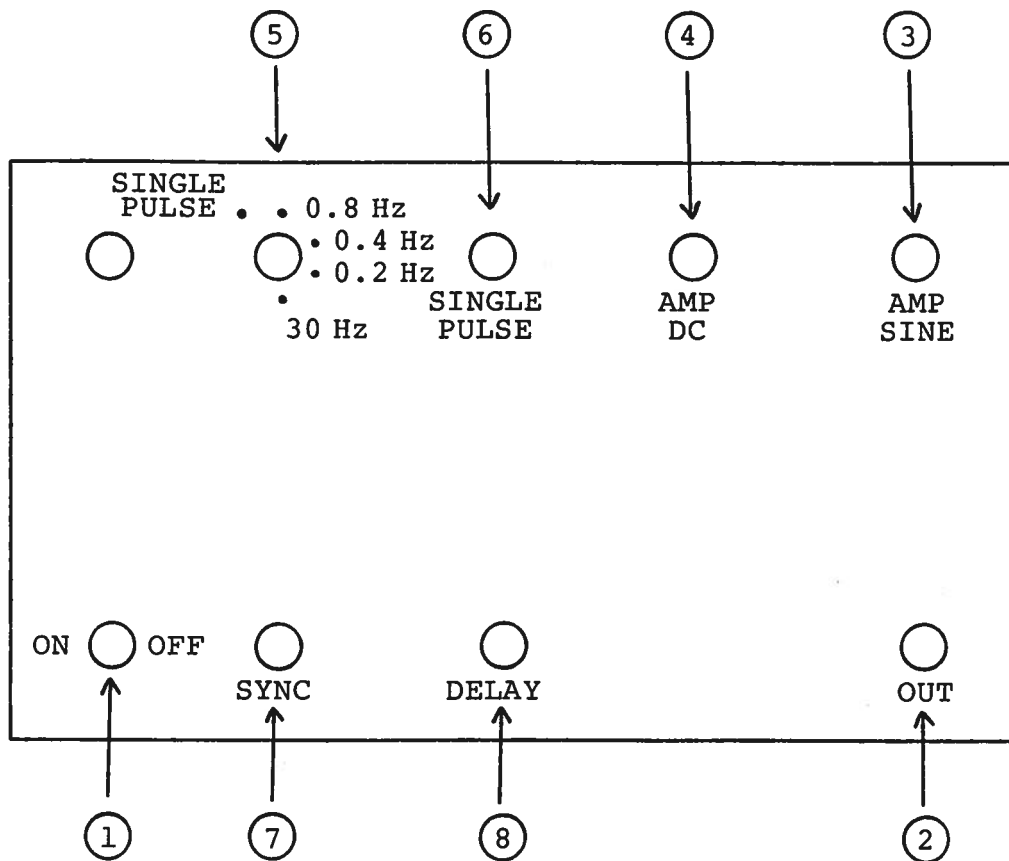

- (1) ON-OFF Switch. Applies prime power to all stages.
- (2) OUT. BNC connector provides a 0 to +50 Ampere 8.3 ms wide sinusoid constant current to a load voltage in the range of 0 to +10 volts. Also provides 100 mA to 1.0 ampere DC constant current to 0 to +5.0 volts load voltage.
- (3) AMP SINE. Ten turn control varies sinusoid output amplitude from 0 to +50 amperes to load voltage in the range of 0 to +10 volts (see Fig. 3).
- (4) AMP DC. Ten turn control varies DC control current output amplitude from 100 mA to 1.10 amperes (to load voltage in the range of 0 to 5 volts). See Fig. 2.
- (5) SELECTOR SWITCH. Five position switch controls Pulse Repetition Frequency of output sinusoid as follows:
 - (6) A) Single Pulse: Provides output pulse for each push of SINGLE PULSE button (6).
 - B) 0.8 Hz: Output sinusoid PRF of about 0.8 Hz.
 - C) 0.4 Hz: Output sinusoid PRF of about 0.4 Hz.
 - D) 0.2 Hz: Output sinusoid PRF of about 0.2 Hz.
 - E) 30 Hz: Sets output sinusoid PRF at about 30 Hz. Peak output amplitude must not exceed 10 Amperes. AMP SINE pot setting must not exceed 4.0
- (7) SYNC. BNC connector provides TTL level 0.2 us wide output pulse (to $R_L \geq 50$ ohms) for scope triggering. TTL pulse lags leading edge of sinusoid output by 10 us to 8.5 ms depending on setting of DELAY pot (8).
- (8) DELAY. Controls relative delay of SYNC TTL output pulse with respect to leading edge of sinusoid output pulse (from 10 us to 8.5 ms).

Fig. 1C

BACK PANEL CONTROLS

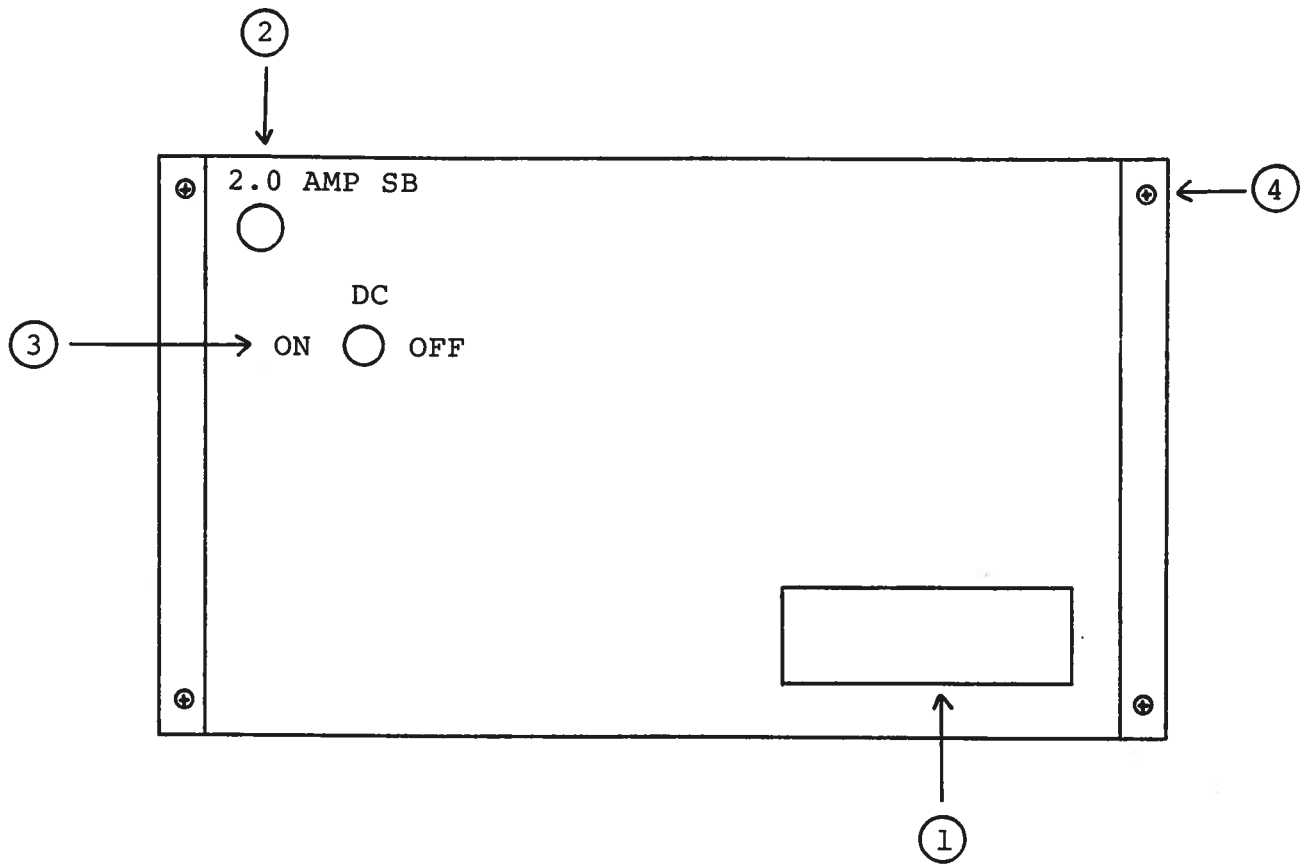

- (1) FUSED CONNECTOR, VOLTAGE SELECTOR. The detachable power cord is connected at this point. In addition, the removable cord is adjusted to select the desired input operating voltage. The unit also contains the main power fuse (1.0A SB).
- (2) 2.0A SB. Fuse which protects the output stage if the output duty cycle rating is exceeded.
- (3) DC ON-OFF. When in ON position front panel AMP DC control varies DC output current from 0.1 to 1.1 Amp. When in OFF position, DC output current is fixed at 0.
- (4) To access interior of instrument, remove four Phillips screws on back panel and then slide top lid back (and off).

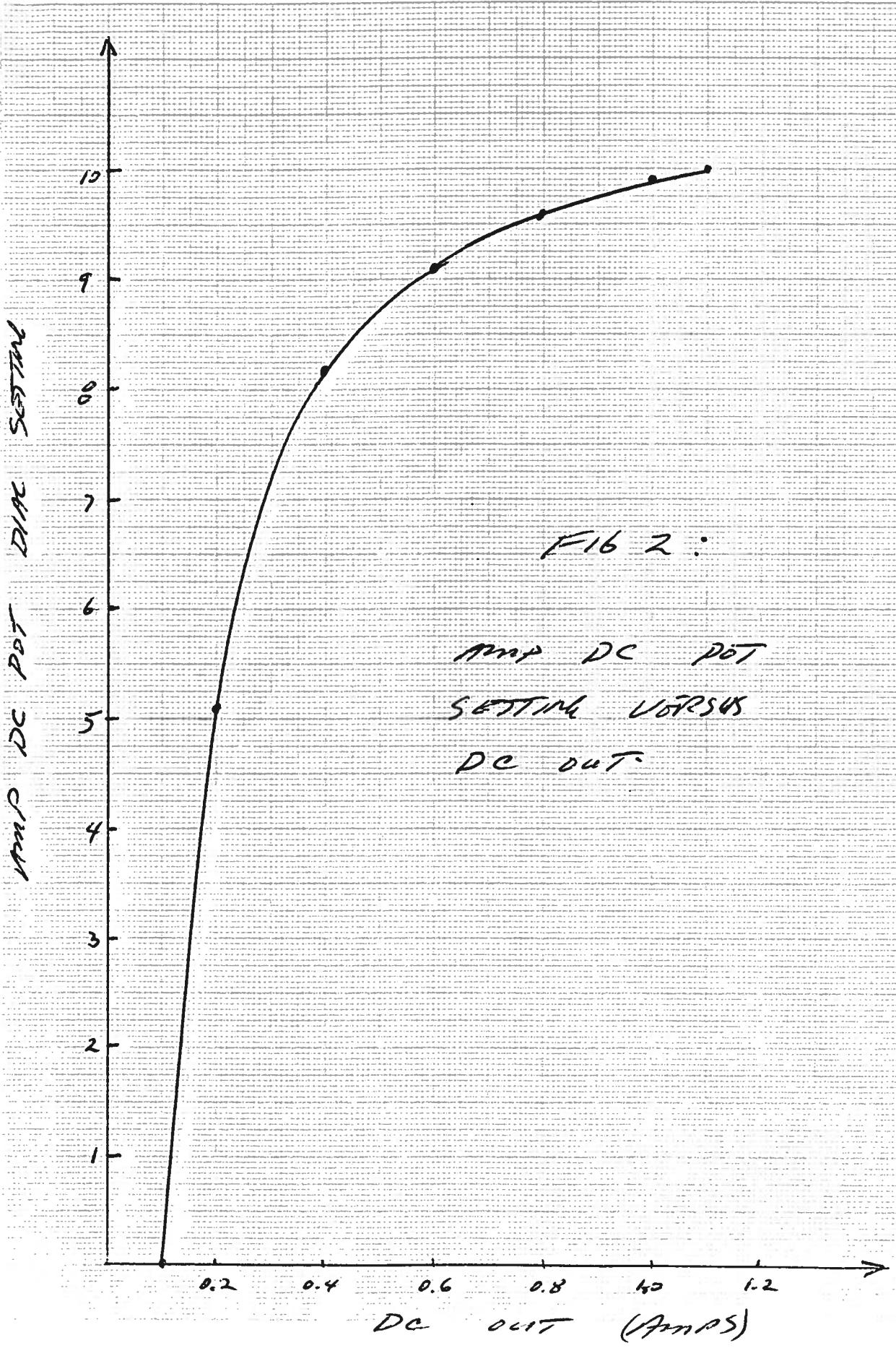

FIG 2:

AMP DC POT
SETTING VERSUS
DC OUT

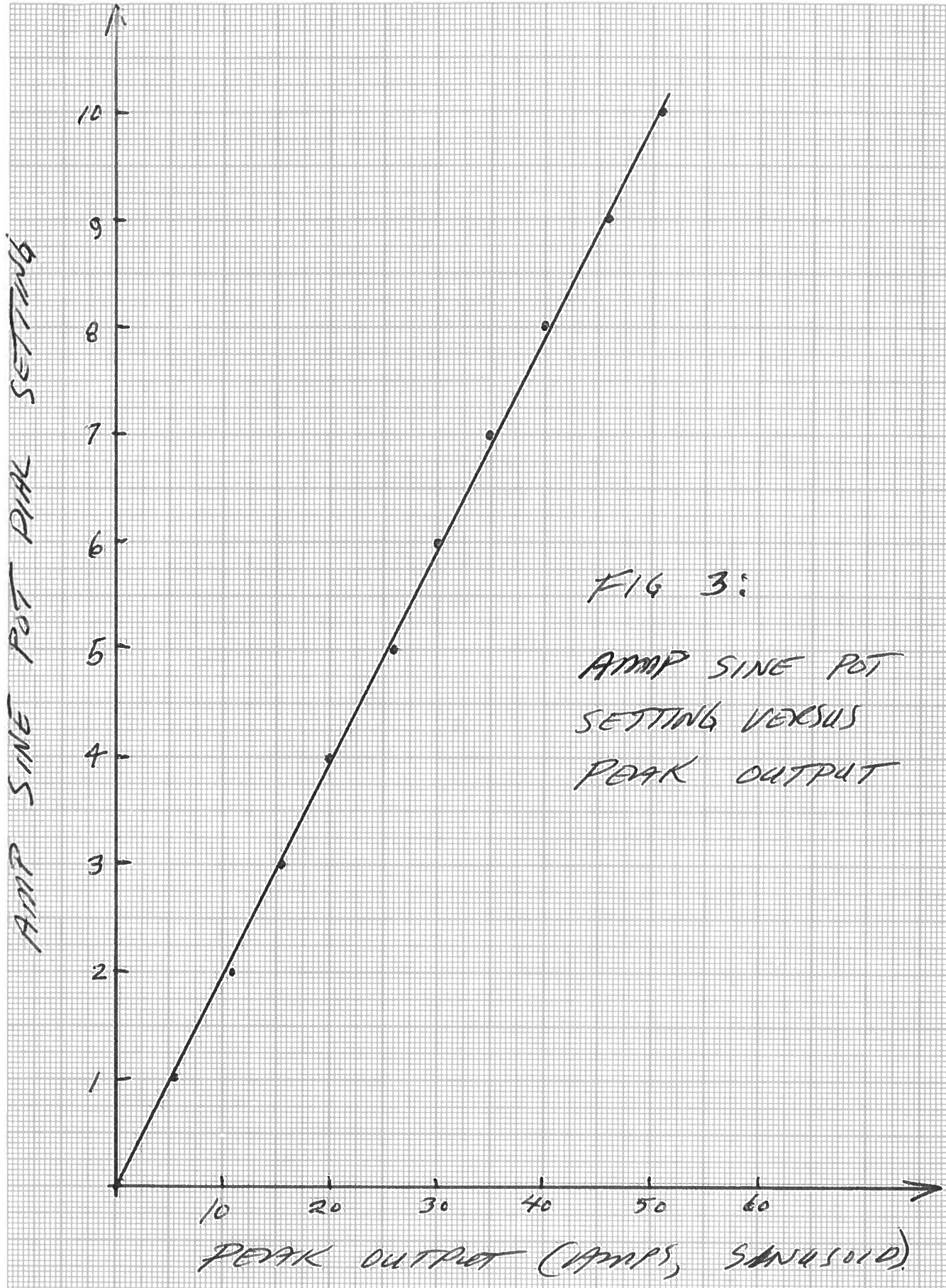
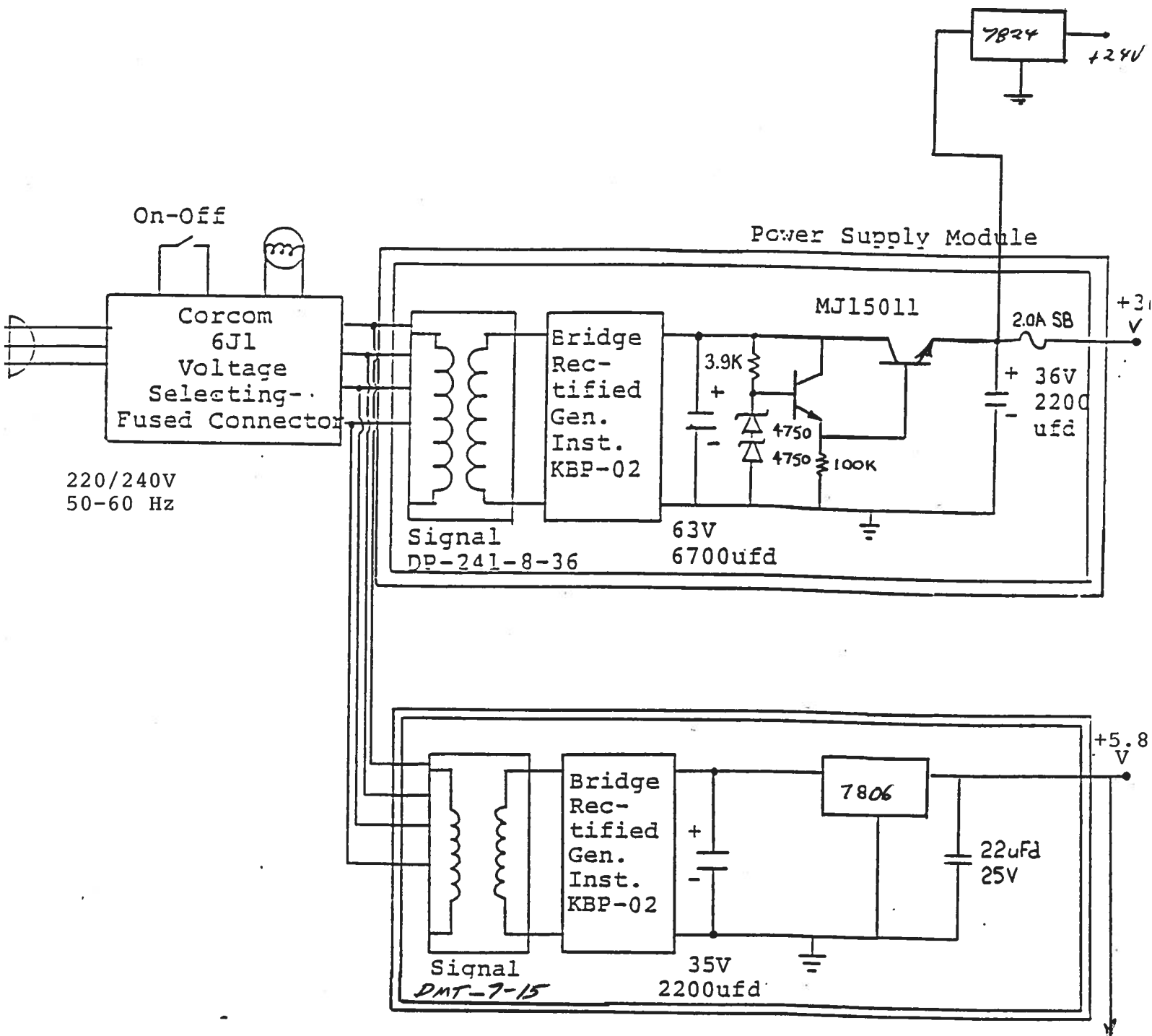

FIG 3:
AMP SINE POT
SETTING VERSUS
PEAK OUTPUT

POWER SUPPLY



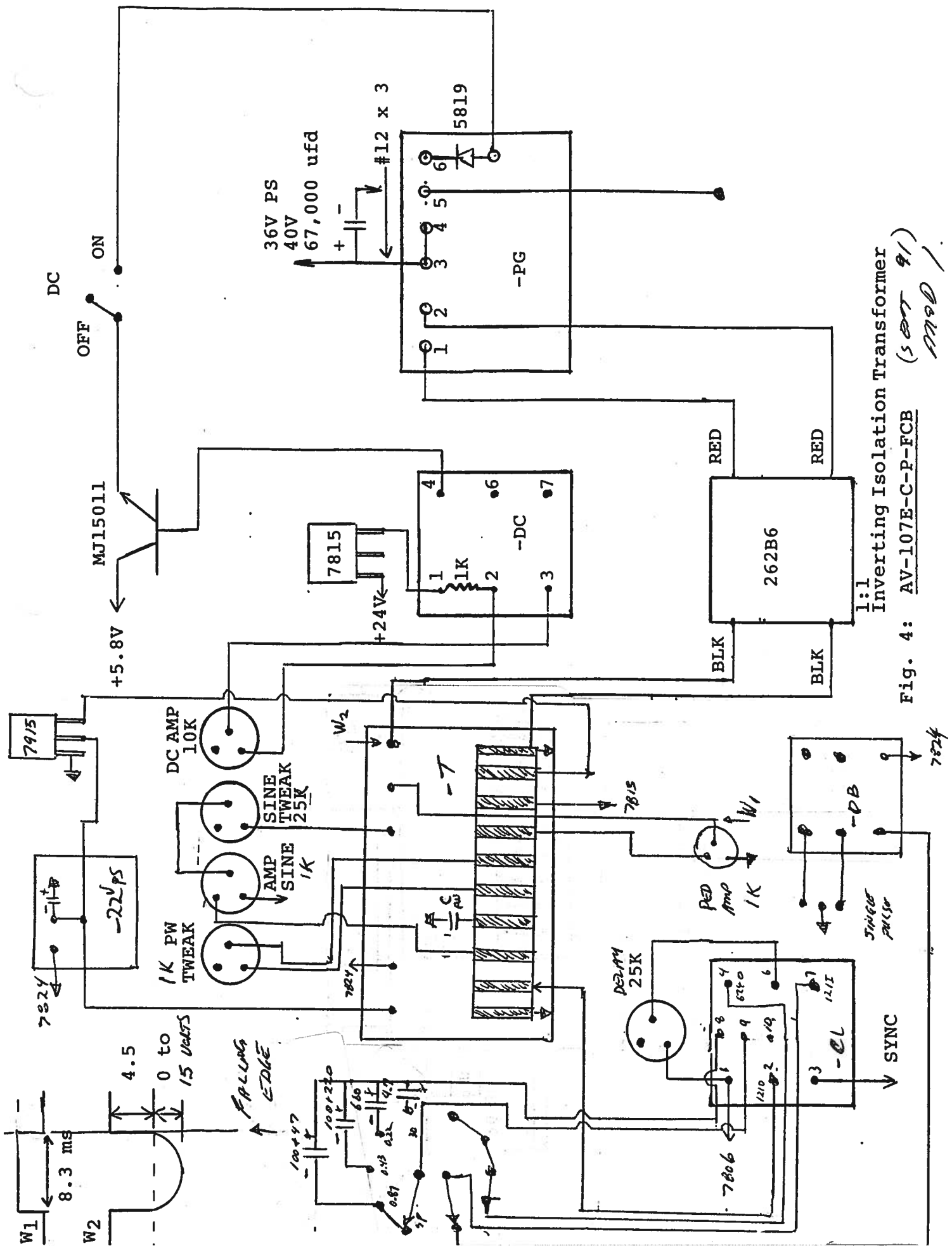

Fig. 4: AV-107E-C-P-FCB
 Inverting Isolation Transformer
 (SER 91)
 MOD 1

SYSTEM DESCRIPTION

The AV-107E-C-P-FCB consists of the following basic modules:

- 1) AV-107E-FCB-PG-SINE sinusoidal constant current pulse module
- 2) AV-107E-FCB-T driver and pulse width control module
- 3) FCB-DC DC constant current control module
- 4) FCB-CL Clock module
- 5) +36V DC power supply
- 6) +5.8V DC power supply
- 7) -22 V DC power supply
- 8) FCD-DB single pulse module

The modules are interconnected as shown in Fig. 4. The key waveforms at module outputs and inputs are also shown in Fig. 4. In the event of an instrument malfunction (i.e. no output) it is most likely that the rear panel 2.0A SB or the 1.0A SB line fuses may have gone. If the fuses are OK and there is still no output, remove the instrument top cover and check the two waveforms W1 and W2. Also, check the +5.8V, -22V, +24V and +36 volt power supply output levels. If the waveforms and levels are not as specified in Fig. 4, then call Avtech for further assistance.

Tel: (613) 226-5772

Fax: (613) 226-2802

Schroff

10.03.91

Handwritten text, possibly a date or reference number.

Main body of handwritten text, appearing to be a letter or report. The text is very faint and mostly illegible due to fading and bleed-through from the reverse side of the page. Some words like "Schroff" and "10.03.91" are faintly visible.

Handwritten text at the bottom of the page, possibly a signature or a closing note.