



AVTECH ELECTROSYSTEMS LTD.

NANOSECOND WAVEFORM ELECTRONICS
SINCE 1975

□ P.O. BOX 265
OGDENSBURG, NY
U.S.A. 13669-0265
TEL: (315) 472-5270
FAX: (613) 226-2802

TEL: 1-800-265-6681
FAX: 1-800-561-1970

e-mail: info@avtechpulse.com
<http://www.avtechpulse.com>

□ P.O. BOX 5120 STN. F
OTTAWA, ONTARIO
CANADA K2C 3H4
TEL: (613) 226-5772
FAX: (613) 226-2802

INSTRUCTIONS

MODEL AV-110B-PS-BTLA AMPLIFIER

S.N.:

WARRANTY

Avtech Electrosystems Ltd. warrants products of its manufacture to be free from defects in material and workmanship under conditions of normal use. If, within one year after delivery to the original owner, and after prepaid return by the original owner, this Avtech product is found to be defective, Avtech shall at its option repair or replace said defective item. This warranty does not apply to units which have been disassembled, modified or subjected to conditions exceeding the applicable specifications or ratings. This warranty is the extent of the obligation assumed by Avtech with respect to this product and no other warranty or guarantee is either expressed or implied.

TECHNICAL SUPPORT

Phone: 613-226-5772 or 1-800-265-6681

Fax: 613-226-2802 or 1-800-561-1970

E-mail: info@avtechpulse.com

World Wide Web: <http://www.avtechpulse.com>

TABLE OF CONTENTS

WARRANTY	i
TECHNICAL SUPPORT	i
FIG.1 BASIC TEST SET-UP	1
GENERAL OPERATING INSTRUCTIONS	2
FIG. 2 FRONT PANEL CONTROLS	4
FRONT PANEL CONTROLS	5
FIG. 3: BACK PANEL CONTROLS	6
BACK PANEL CONTROLS	7
PERFORMANCE CHECK SHEET	8

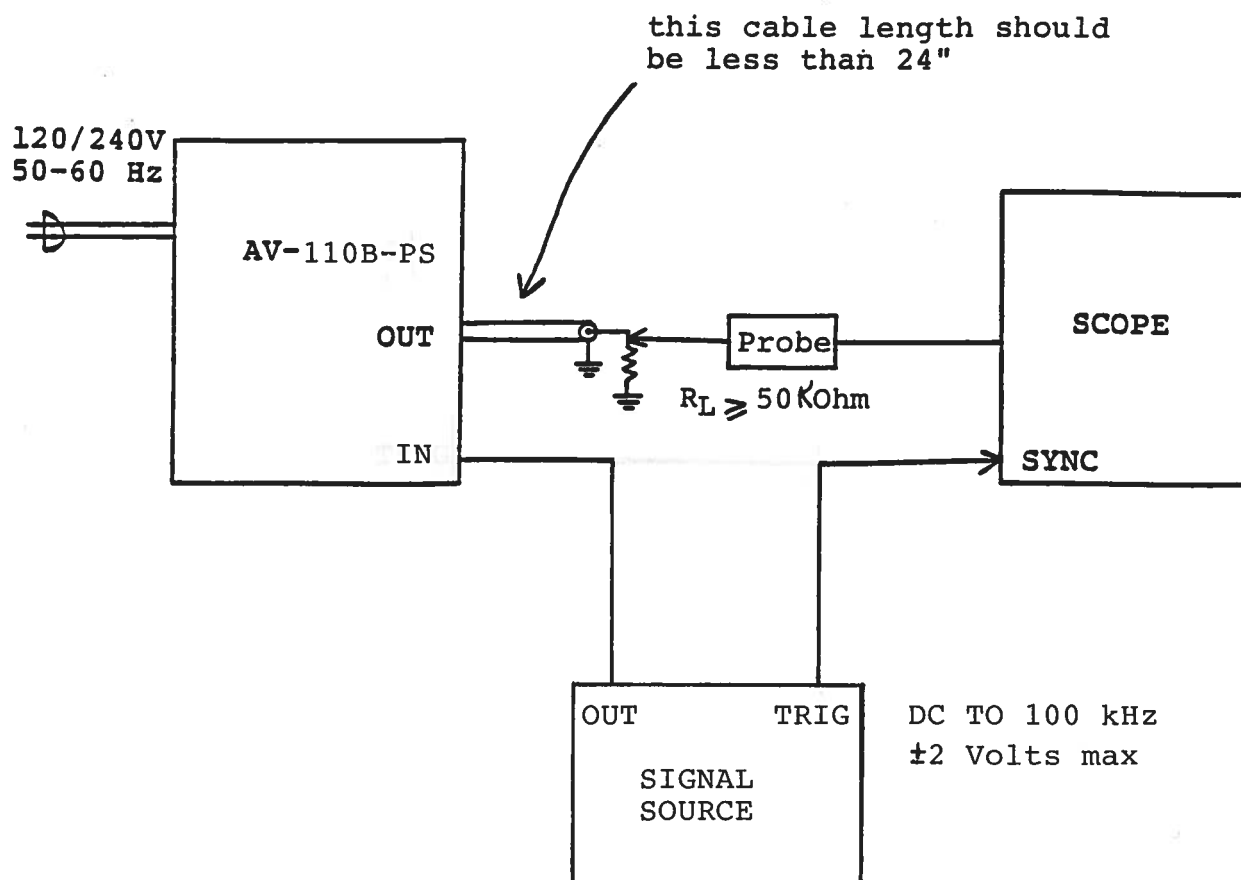
FIG.1 BASIC TEST SET-UP

GENERAL OPERATING INSTRUCTIONS

- 1) Connect the instrument as shown above. Do not apply prime power.
- 2) Terminate OUT in a load impedance of 50K (or higher). Note that the length of 50 Ohm cable between the output connector and the load should be less than 24" in order to avoid distortion of the waveform.
- 3) Set the amplitude control to maximum counter clockwise.
- 4) Set the two position front panel switch on the non-inverted position.
- 5) Set the input signal amplitude at 4 Volts (peak to peak) and the frequency at 10 kHz.
- 6) Set the scope time base on about 20 us/div and the vertical on about 50 Volts/div and set the scope time base to trigger on EXT (+).
- 7) Turn on the prime power and adjust scope trigger controls to obtain a trace.
- 8) Rotate the amplitude control clockwise to obtain the desired output amplitude (as high as 400 Volts peak to peak).
- 9) Set the front panel two position switch in the inverted mode and note the 180° reversal in output phase (or polarity).
- 10) **CAUTION:** Take great care not to operate into a low impedance (i.e. < 50K) or into a short circuit as this may result in damage to the output stage.
- 11) Units with a serial number higher than 5600 are protected by an automatic overload protective circuit which controls the front panel overload light. If the unit is overloaded (by operating at an exceedingly high duty cycle or by operating into a short circuit), the protective circuit will turn the output of the instrument OFF and turn the indicator light ON. The light will stay ON (i.e. output OFF) for about 5 seconds after which the instrument will attempt to turn ON (i.e. light OFF) for about 1 second. If the overload condition persists, the instrument will turn OFF again (i.e. light ON) for another 5 seconds. If the overload condition has been removed, the instrument will turn on and resume normal operation. Overload conditions may be removed by:
 - 1) Removing output load short circuit (if any)
 - 2) Reducing the output amplitude

Note the overload light may activate when the prime power is turned on. The light will extinguish after a few seconds.

- 12) The unit can be converted from 110 to 220V 50-60 Hz operation by adjusting the voltage selector card in the rear panel fused voltage selector-cable connector assembly.
- 13) For additional assistance:
Tel: (613) 226-5772
Fax: (613) 226-2802

FIG. 2 FRONT PANEL CONTROLS

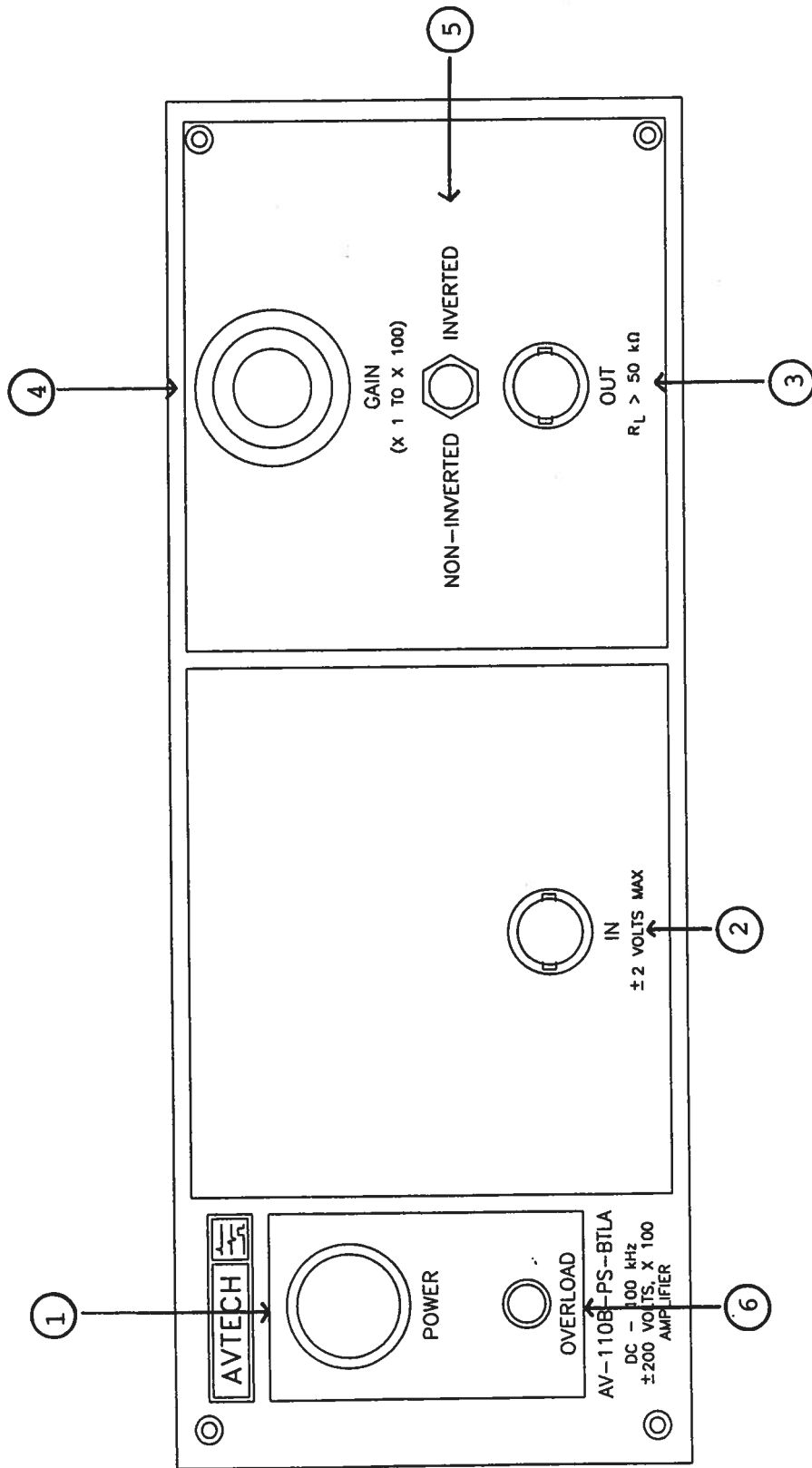

FRONT PANEL CONTROLS

- (1) ON-OFF Switch. Applies prime power to all stages.
- (2) IN. The input signal is applied to this BNC connector (max 4 Volts peak to peak, DC to 100kHz).
- (3) OUT. BNC connector provides output to high impedance load ($\geq 50K$).
- (4) AMPLITUDE. Ten turn control determines amplitude of output.
- (5) NON-INVERT, INVERT. Two position switch converts amplifier from non-inverting to inverting mode.
- (6) OVERLOAD. Units with a serial number higher than 5600 are protected by an automatic overload protective circuit which controls the front panel overload light. If the unit is overloaded (by operating at an exceedingly high duty cycle or by operating into a short circuit), the protective circuit will turn the output of the instrument OFF and turn the indicator light ON. The light will stay ON (i.e. output OFF) for about 5 seconds after which the instrument will attempt to turn ON (i.e. light OFF) for about 1 second. If the overload condition persists, the instrument will turn OFF again (i.e. light ON) for another 5 seconds. If the overload condition has been removed, the instrument will turn on and resume normal operation. Overload conditions may be removed by:
 - 1) Removing output load short circuit (if any)
 - 2) Reducing the output amplitude

Note that the overload light may come on when the prime power is applied. The light will extinguish after a few seconds.

FIG. 3: BACK PANEL CONTROLS

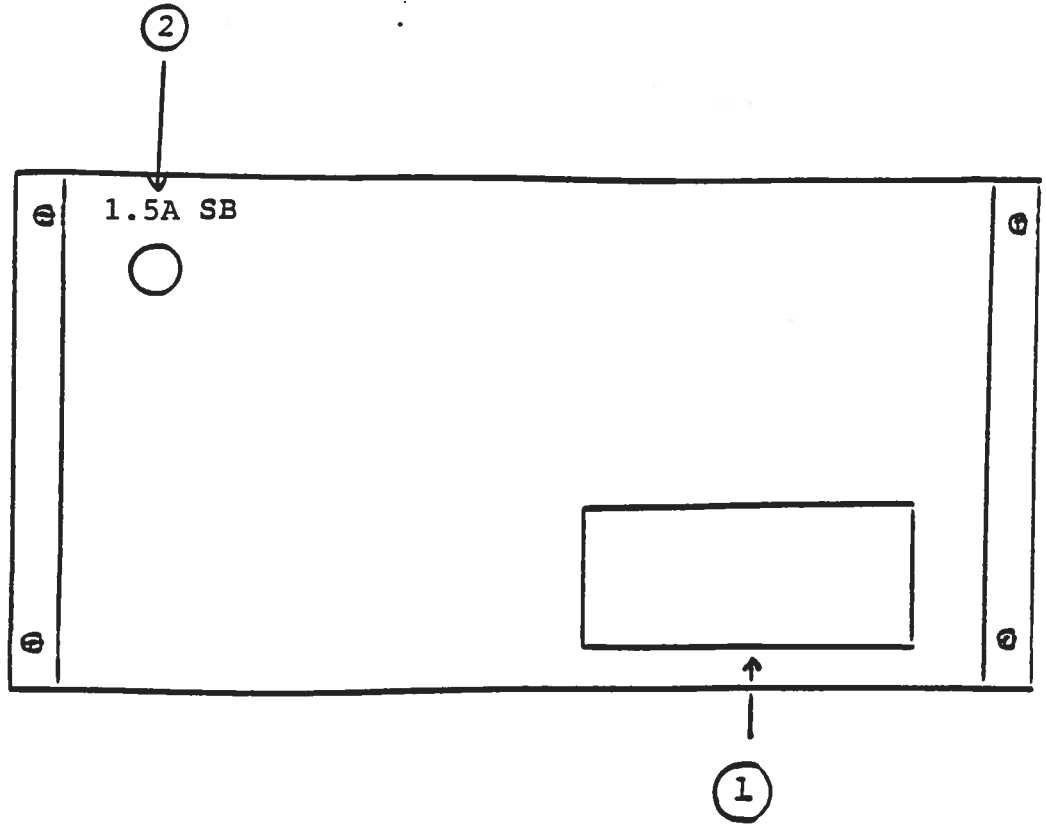

BACK PANEL CONTROLS

- (1) FUSED CONNECTOR, VOLTAGE SELECTOR. The detachable power cord is connected at this point. In addition, the removable cord is adjusted to select the desired input operating voltage. The unit also contains the main power fuse (0.5A SB).
- (2) 1.0A SB. Fuse which protects the output stage if the output duty cycle rating is exceeded.

PERFORMANCE CHECK SHEET

Sept 11/98

unstructured | av110 | av-110b-ps-btla.doc