



**AVTECH ELECTROSYSTEMS LTD.**

NANOSECOND WAVEFORM ELECTRONICS  
SINCE 1975

P.O. BOX 265  
OGDENSBURG, NY  
U.S.A. 13669-0265  
TEL: (315) 472-5270  
FAX: (613) 226-2802

TEL: 1-800-265-6681  
FAX: 1-800-561-1970  
U.S.A. & CANADA

e-mail: [info@avtechpulse.com](mailto:info@avtechpulse.com)

BOX 5120 STN. F  
OTTAWA, ONTARIO  
CANADA K2C 3H4  
TEL: (613) 226-5772  
FAX: (613) 226-2802

INSTRUCTIONS

MODEL AV-141C AMPLIFIER

S.N. :

### WARRANTY

Avtech Electrosystems Ltd. warrants products of its manufacture to be free from defects in material and workmanship under conditions of normal use. If, within one year after delivery to the original owner, and after prepaid return by the original owner, this Avtech product is found to be defective, Avtech shall at its option repair or replace said defective item. This warranty does not apply to units which have been disassembled, modified or subjected to conditions exceeding the applicable specifications or ratings. This warranty is the extent of the obligation or liability assumed by Avtech with respect to this product and no other warranty or guarantee is either expressed or implied.

## Model AV-141C

### General Instructions

The Model AV-141C amplifier is designed to amplify bipolar nanosecond rise time baseband pulses in the pulse width range of about 2.0 ns and higher and CW signals in the frequency range of DC to 600 MHz. The basic specifications for the unit are as follows:

Gain:	> 20 dB
Peak output voltage:	±3 Volt
Rise time:	< 1.0 ns
Impedance level:	50 Ohms nominal
Bandwidth:	DC to 600 MHz
Max. noise figure:	4 nV/√Hz
Prime power:	+5.0 Volts, 50 mA max -5.0 Volts, 50 mA max
Connectors:	SMA
Size:	1.4 x 1.1 x 2.3 inches

- 1) The pulse mode operation of the unit was tested using the arrangement shown in Fig. 1.
- 2) CAUTION: The unit may be damaged if the DC voltage power supply voltage exceeds ±5.2 Volts or if the power supply voltages are reversed.

Fig. 1

AMPLIFIER TEST ARRANGEMENT

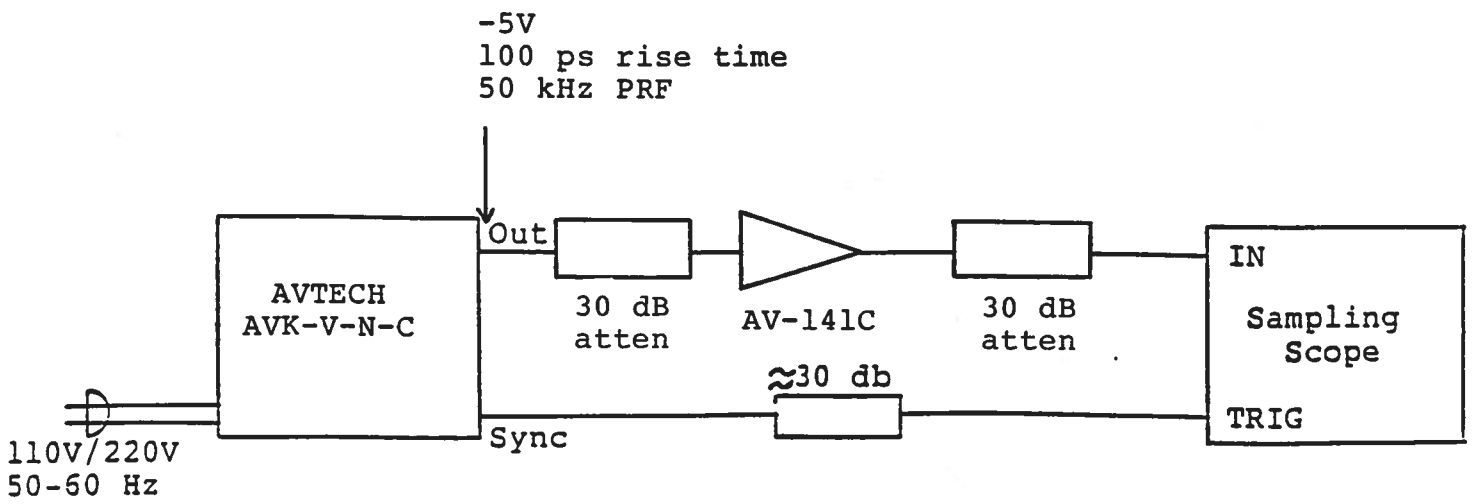

May 16/95

edition A

Disk: AV-

Name: 14ICEDA.INS