



AVTECH ELECTROSYSTEMS LTD.

NANOSECOND WAVEFORM ELECTRONICS
SINCE 1975

P.O. BOX 265
OGDENSBURG, NY
U.S.A. 13669-0265
TEL: (315) 472-5270
FAX: (613) 226-2802

TEL: 1-800-265-6681
FAX: 1-800-561-1970
U.S.A. & CANADA

e-mail: info@avtechpulse.com

BOX 5120 STN. F
OTTAWA, ONTARIO
CANADA K2C 3H4
TEL: (613) 226-5772
FAX: (613) 226-2802

INSTRUCTIONS

MODEL AV-141D AMPLIFIER

S.N. :

WARRANTY

Avtech Electrosystems Ltd. warrants products of its manufacture to be free from defects in material and workmanship under conditions of normal use. If, within one year after delivery to the original owner, and after prepaid return by the original owner, this Avtech product is found to be defective, Avtech shall at its option repair or replace said defective item. This warranty does not apply to units which have been disassembled, modified or subjected to conditions exceeding the applicable specifications or ratings. This warranty is the extent of the obligation or liability assumed by Avtech with respect to this product and no other warranty or guarantee is either expressed or implied.

MODEL AV-141D

GENERAL INSTRUCTIONS

The Model AV-141D amplifier is designed to amplify bipolar nanosecond rise time baseband pulses in the pulse width range of about 5.0 ns and higher and CW signals in the frequency range of DC to 150 MHz. The basic specifications for the unit are as follows:

Gain:	> 20 dB
Peak output voltage:	± 3 Volt
Rise time:	< 3.0 ns
Impedance level:	50 Ohms nominal
Bandwidth:	DC to 15 MHz
Max. noise figure:	3.2 nV/ $\sqrt{\text{Hz}}$
Prime power:	+15 Volts, 50 mA max -15 Volts, 50 mA max
Connectors:	SMA
Size:	1.4 x 1.1 x 2.3 inches

- 1) The DC offset on the output may be set to zero by making minor adjustments to the OS trim pot on the "OUT" end of the chassis.
- 2) The pulse mode operation of the unit was tested using the arrangement shown in Fig. 1.
- 3) CAUTION: The unit may be damaged if the DC voltage power supply voltage exceeds ±18.0 Volts or if the power supply voltages are reversed. The 1N4746A zener diodes are installed across the ±15 VDC input terminals to protect the unit against these factors. Note that the input power supply voltages may be as low as ±7 Volts.

Fig. 1

AMPLIFIER TEST ARRANGEMENT

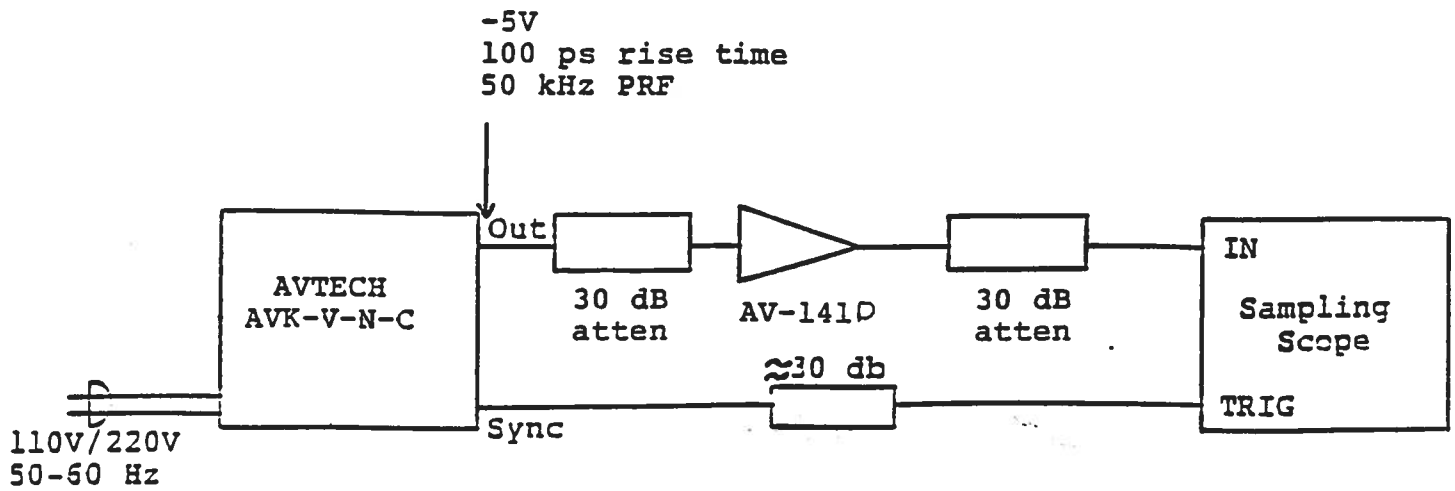

Jan. 28/97

Edition A (as of Sept 12/97)

Disk = AV-

Name = 141D-A.INS