

MOOR

N 144A2 - GILD

COOR 31FEET?

## GENERAL OPERATING INSTRUCTIONS

- 1) The operating mode of this pulse generator is controlled by the control panel shown in Fig. 1. This control panel is accessed by removing the lid on the side of the module, which is normally held in place by four 2-56 Phillips screws. The top lid (held on by eight 4-40 screws) should never be removed.
- 2) The pulse width range is controlled by positions 3, 4, and 5 of the right DIP switch (see Fig. 1), as listed below:

Right DIP, Pos. 3: if "on", pulse width range is 1 - 10 us

Right DIP, Pos. 4: if "on", pulse width range is 10 - 100 us

Right DIP, Pos. 5: if "on", pulse width range is 100 us - 1 ms

Only one of these switches should be "on" at a time. If more than one is selected, the pulse width range will be different.

- 3) The pulse width (PW) is varied within the selected range by positions 1-8 of the left DIP switch, and positions 9 and 10 of the right DIP switch, as listed below:

Left DIP, Pos. 1: if "on", PW is 1/10 of the range maximum.

Left DIP, Pos. 2: if "on", PW is 2/10 of the range maximum.

Left DIP, Pos. 3: if "on", PW is 3/10 of the range maximum.

Left DIP, Pos. 4: if "on", PW is 4/10 of the range maximum.

Left DIP, Pos. 5: if "on", PW is 5/10 of the range maximum.

Left DIP, Pos. 6: if "on", PW is 6/10 of the range maximum.

Left DIP, Pos. 7: if "on", PW is 7/10 of the range maximum.

Left DIP, Pos. 8: if "on", PW is 8/10 of the range maximum.

Right DIP, Pos. 1: if "on", PW is 9/10 of the range maximum.

Right DIP, Pos. 2: if "on", PW is 10/10 of the range maximum.

Only one of these switches should be "on" at a time. If more than one is selected, the lowest selected pulse width will be used.

- 4) The trigger source is controlled by position 6 of the right DIP switch:

Right DIP, Pos. 6: if "on", the module is triggered by the TTL signal on the "IN" input BNC connector. The input pulse width should be greater than 50 ns.

Right DIP, Pos. 6: if "off", the module is triggered by the internal 30 Hz source.

- 5) The amplitude control can be switched by position 7 of the right DIP switch:

Right DIP, Pos. 7: if "on", the amplitude is controlled by the Amplitude Control Pot (see Fig. 1). The amplitude increases from 0V to 5V as the pot is rotated clockwise.

Right DIP, Pos. 7: if "off", the amplitude is controlled by the voltage on the "A" SMA input connector. Zero voltage on "A" corresponds to the minimum amplitude of 0 V, and +5V on "A" corresponds to maximum amplitude of +5V. The voltage on the "A" input should remain in the 0 to 5V range.

- 6) The output pulse can be inverted or non-inverted, depending on position 8 of the right DIP switch:

Right DIP, Pos. 8: if "on", the output is non-inverted. The output voltage is zero when not triggered, and rises when triggered. See Fig. 3.

Right DIP, Pos. 8: if "off", the output is inverted. The output voltage is +5V when not triggered, and falls when triggered. See Fig. 3.

- 7) The AV-144A2-GILLD requires +15.0 V (200 mA maximum) and -15.0 V (200 mA maximum) prime power. It is recommended that the module be bolted to a heatsink.

- 8) The source impedance of the AV-144A2-GILLD is 100  $\Omega$ . The output is short-circuited protected by a 100  $\Omega$  series resistor.

- 9) The basic operation of the pulse generator was confirmed using the test set-up shown in Fig. 2.

- 10) For additional information:

Tel: (613) 226-5772

Fax: (613) 226-2802

Email: [info@avtechpulse.com](mailto:info@avtechpulse.com)

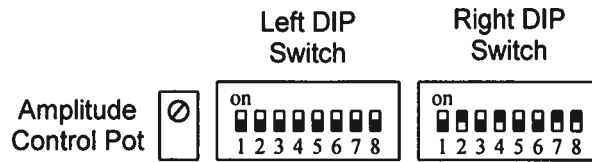

**FIG. 1** **CONTROL PANEL**

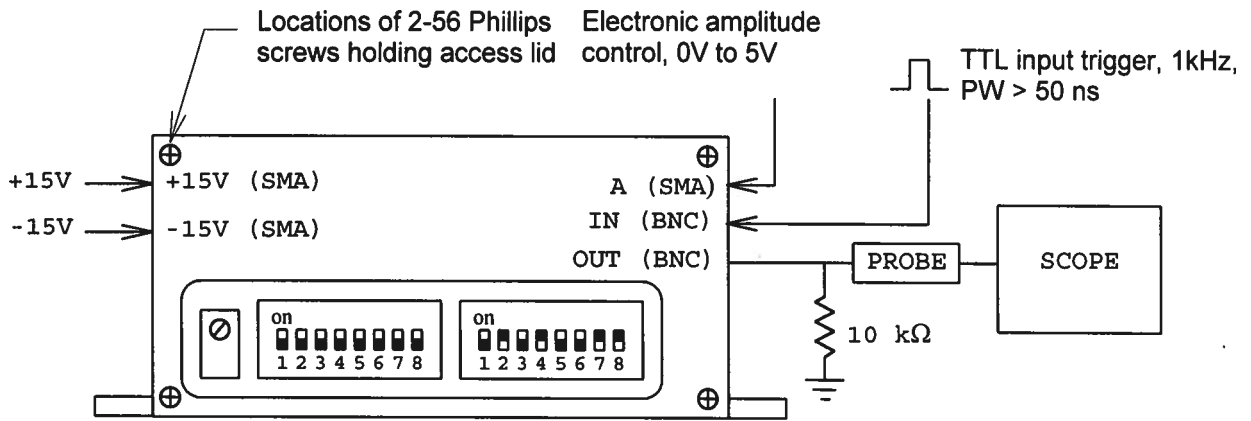

With the DIP switches set as shown, the module will trigger from the internal 30 Hz source, and will have an output pulse width of 100  $\mu$ s. The amplitude will be controlled by the Amplitude Control Pot, and the output will be non-inverted.

To trigger externally using the TTL signal on the "IN" connector, set position 6 of the right DIP switch to the "on" position.

To control the amplitude with the voltage on the "A" input, set position 7 of the right DIP switch to the off position.

To obtain an inverted output, set position 8 of the right DIP switch to the off position.

**FIG. 2**

**BASIC TEST SET-UP**

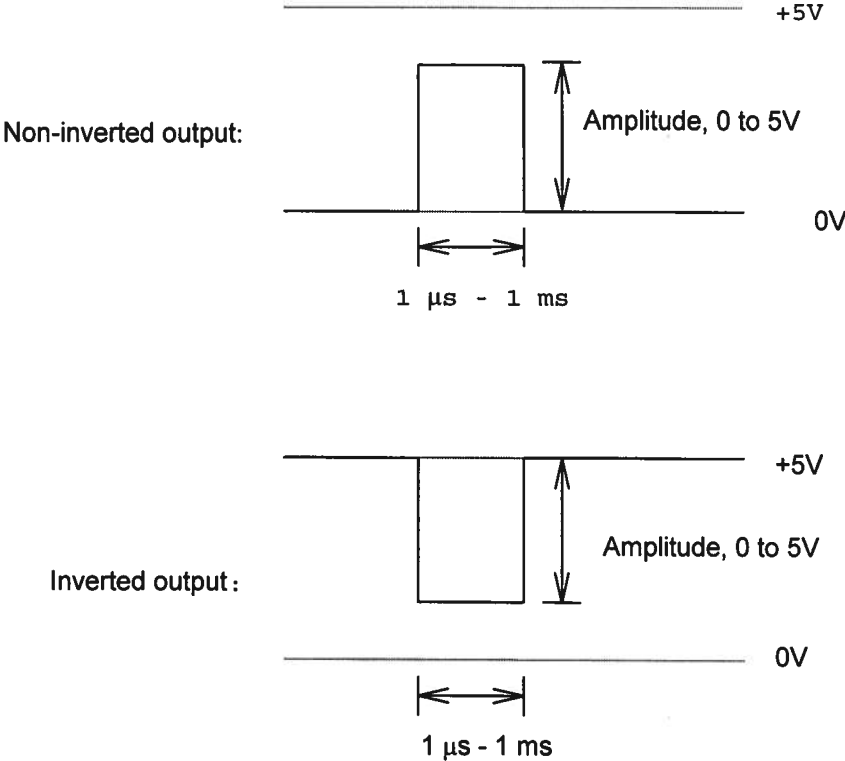

**FIG. 3**

**OUTPUT WAVEFORMS**

Updated until 8/99