



AVTECH ELECTROSYSTEMS LTD.

NANOSECOND WAVEFORM ELECTRONICS
SINCE 1975

P.O. BOX 265
OGDENSBURG, NY
U.S.A. 13669-0265
TEL: (315) 472-5270
FAX: (613) 226-2802

TEL: 1-800-265-6681
FAX: 1-800-561-1970
U.S.A. & CANADA

e-mail: info@avtechpulse.com

BOX 5120 STN. F
OTTAWA, ONTARIO
CANADA K2C 3H4
TEL: (613) 226-5772
FAX: (613) 226-2802

INSTRUCTIONS

MODEL AV-149-BW1-5K-APD-SP2-A-NC-PD2 TRANSIMPEDANCE AMPLIFIER

S.N. :

WARRANTY

Avtech Electrosystems Ltd. warrants products of its manufacture to be free from defects in material and workmanship under conditions of normal use. If, within one year after delivery to the original owner, and after prepaid return by the original owner, this Avtech product is found to be defective, Avtech shall at its option repair or replace said defective item. This warranty does not apply to units which have been disassembled, modified or subjected to conditions exceeding the applicable specifications or ratings. This warranty is the extent of the obligation or liability assumed by Avtech with respect to this product and no other warranty or guarantee is either expressed or implied.

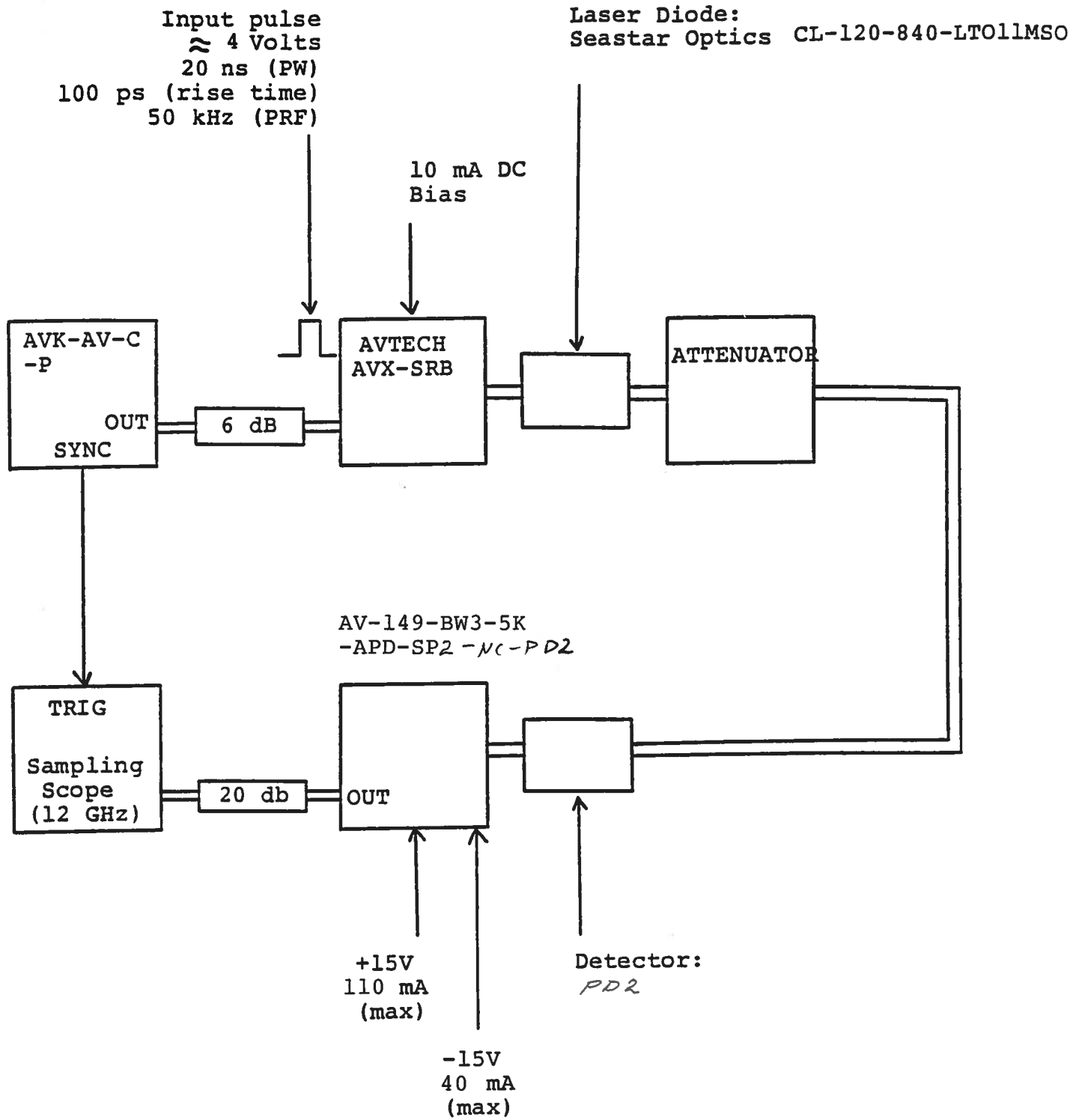

Fig. 1

BASIC TEST SET-UP (PULSE MODE)

GENERAL OPERATING INSTRUCTIONS

- 1) The basic operation of the amplifier was confirmed using the pulse mode test arrangement shown in Fig. 1.
- 2) The AV-149 amplifier requires a prime power of ± 15 VDC (110 mA max).
- 3) The bias voltage for the APD may be varied from about +20 Volts to +228 using the 10 turn "BIAS ADJ" screw. Note clockwise rotation of the screw reduces the bias voltage while counterclockwise rotation increases the bias voltage. At the time of shipping this voltage was set to +50 Volts (as measured at the red "BIAS" banana terminal adjacent to the "BIAS ADJ" screw).
- 4) To test the AV-149 in a sweep frequency mode (DC to 600 MHz) the AVK-AV-C and the sampling scope should be replaced by a network analyzer.
- 5) CAUTION: The amplifier will be damaged if the anode and cathode connections are reversed.
- 6) The leads of the photo diode should not be inserted more than 1.0 cm into the socket. Note that the unit was shipped with the PD2 diode installed in the 3 PIN socket and that a nylon spacer washer is placed between the AV-149 chassis and the diode package.
- 7) The ± 15 VDC supply should be turned off when installing or removing the photo diode.
- 8) The DC offset on the output may be adjusted from 0 to ± 1.0 Volts using the 10 turn trim pot which is accessible on the detector side of the chassis.
- 9) For additional information:

Tel: (613) 226-5772

Fax: (613) 226-2802

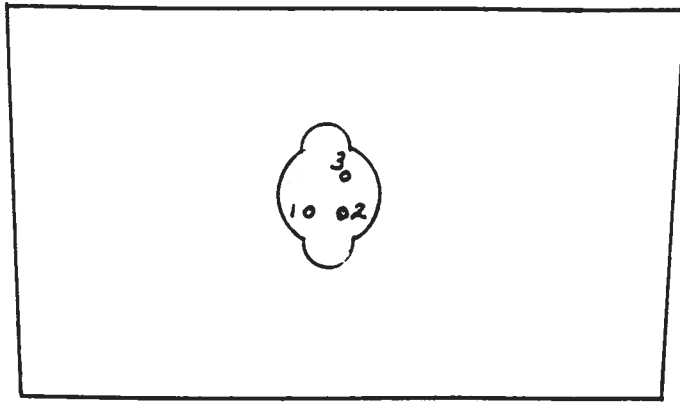

Fig. 2 DIODE SOCKET PIN CONNECTIONS

- 1) ANODE
- 3) CASE
- 2) CATHODE

Oct. 7/96

Disk: AV-

Name: 49BW15KA.INS