



AVTECH ELECTROSYSTEMS LTD.

NANOSECOND WAVEFORM ELECTRONICS
SINCE 1975

P.O. BOX 265
OGDENSBURG, NY
U.S.A. 13669-0265
TEL: (315) 472-5270
FAX: (613) 226-2802

TEL: 1-800-265-6681
FAX: 1-800-561-1970
U.S.A. & CANADA

e-mail: info@avtechpulse.com

BOX 5120 STN. F
OTTAWA, ONTARIO
CANADA K2C 3H4
TEL: (613) 226-5772
FAX: (613) 226-2802

INSTRUCTIONS

MODEL AV-149-BW1-5K-PIN-SP1-A-FC-PD3 TRANSIMPEDANCE AMPLIFIER

S.N. :

WARRANTY

Avtech Electrosystems Ltd. warrants products of its manufacture to be free from defects in material and workmanship under conditions of normal use. If, within one year after delivery to the original owner, and after prepaid return by the original owner, this Avtech product is found to be defective, Avtech shall at its option repair or replace said defective item. This warranty does not apply to units which have been disassembled, modified or subjected to conditions exceeding the applicable specifications or ratings. This warranty is the extent of the obligation or liability assumed by Avtech with respect to this product and no other warranty or guarantee is either expressed or implied.

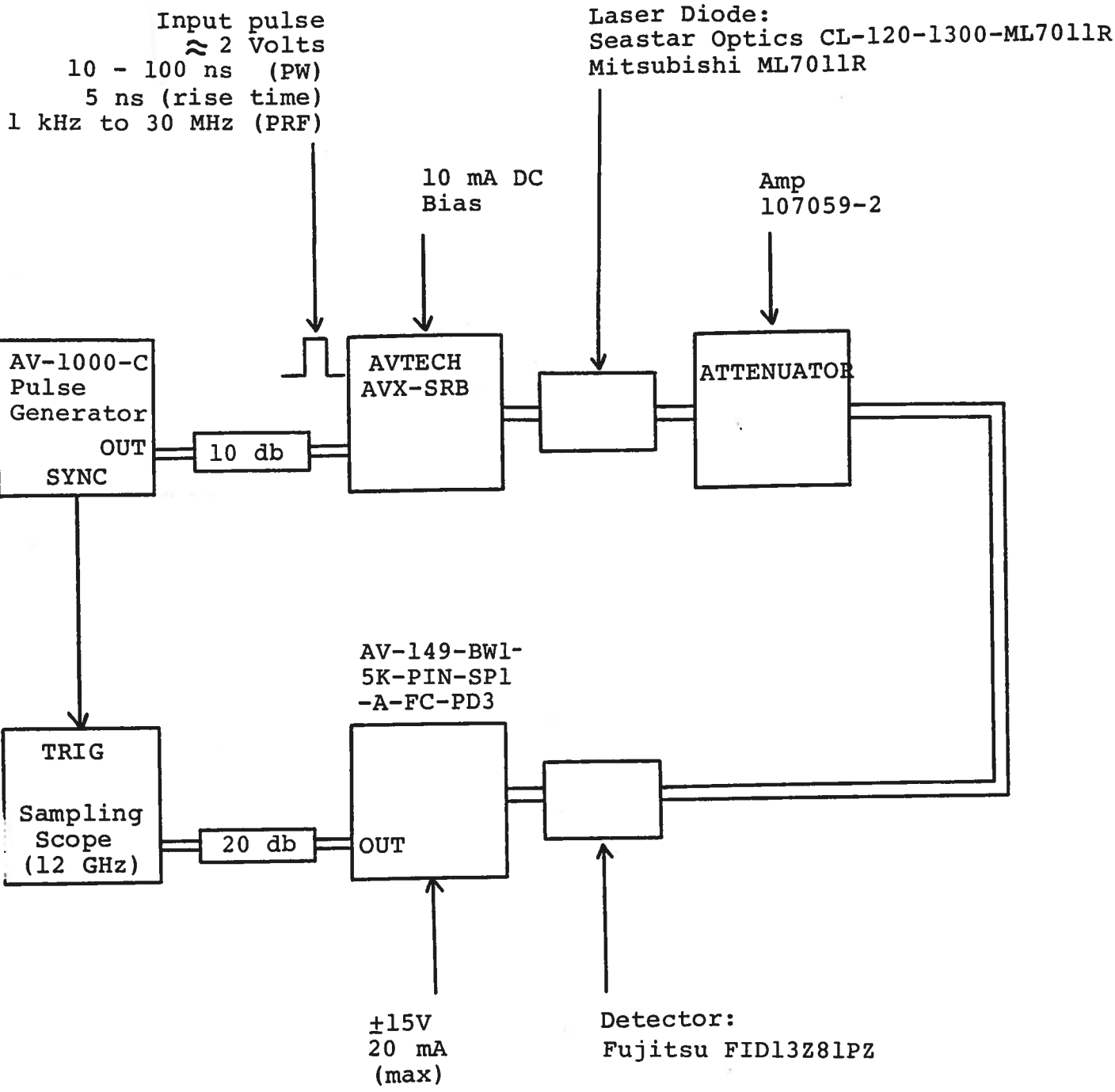

Fig. 1

BASIC TEST SET-UP (PULSE MODE)

GENERAL OPERATING INSTRUCTIONS

- 1) The basic operation of the amplifier was confirmed using the pulse mode test arrangement shown in Fig. 1.
- 2) The AV-149 amplifier requires a prime power of ± 15 VDC (20 mA max).
- 3) To test the AV-149 in a sweep frequency mode (DC to 30 MHz) the AV-1000-C and the sampling scope should be replaced by a network analyzer.
- 4) The connectorized detector diode may be removed by removing the 2 Phillips 2-56 screws which affix the diode assembly to the 2 x 5 cm aluminum mounting plate in the side of the amplifier. The diode may then be removed from the socket by gently pulling the diode package away from the amplifier chassis. The aluminum mounting plate may be removed by loosening the 8-32 nuts (4) then removing the 8-32 machine screws (2). Other PIN detector diodes may be inserted into the socket. The pin connections are as shown in Fig. 2.
- 5) For additional information:

Tel: (613) 226-5772

Fax: (613) 226-2802

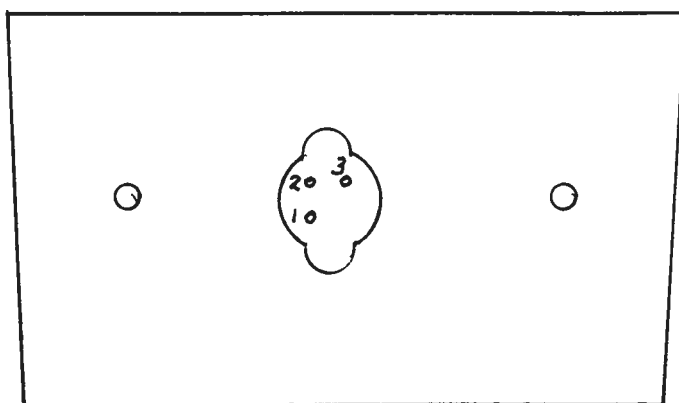

Fig. 2 DIODE SOCKET PIN CONNECTIONS

- 1) ANODE
- 2) CASE
- 3) CATHODE

Oct. 4/95

Disk: AV-

Name: 149BW15K.INS