



AVTECH ELECTROSYSTEMS LTD.

NANOSECOND WAVEFORM ELECTRONICS
SINCE 1975

P.O. BOX 265
OGDENSBURG, NY
U.S.A. 13669-0265
TEL: (315) 472-5270
FAX: (613) 226-2802

TEL: 1-800-265-6681
FAX: 1-800-561-1970

e-mail: info@avtechpulse.com
<http://www.avtechpulse.com>

P.O. BOX 5120 STN. F
OTTAWA, ONTARIO
CANADA K2C 3H4
TEL: (613) 226-5772
FAX: (613) 226-2802

INSTRUCTIONS

MODEL AV-155A-C PULSE GENERATOR

S.N.:

WARRANTY

Avtech Electrosystems Ltd. warrants products of its manufacture to be free from defects in material and workmanship under conditions of normal use. If, within one year after delivery to the original owner, and after prepaid return by the original owner, this Avtech product is found to be defective, Avtech shall at its option repair or replace said defective item. This warranty does not apply to units which have been disassembled, modified or subjected to conditions exceeding the applicable specifications or ratings. This warranty is the extent of the obligation assumed by Avtech with respect to this product and no other warranty or guarantee is either expressed or implied.

TECHNICAL SUPPORT

Phone: 613-226-5772 or 1-800-265-6681

Fax: 613-226-2802 or 1-800-561-1970

E-mail: info@avtechpulse.com

World Wide Web: <http://www.avtechpulse.com>

CAUTION

To avoid possible damage to the laser diode, the following start up and shut down sequences should be followed:

START UP SEQUENCE

- 1) POWER switch is OFF (i.e. button out).
- 2) Set amplitude controls fully CCW.
- 3) Set OPERATE-STANDBY switch to STANDBY position.
- 4) Connect the laser diode to the output terminals.
- 5) Apply prime power by setting the POWER switch in the ON position (i.e. push button in).
- 6) Set OPERATE-STANDBY switch to OPERATE position.
- 7) Set amplitude to desired level. Do not change the position of the OPERATE-STANDBY switch from OPERATE to STANDBY without first setting the amplitude controls to fully CCW.

SHUT DOWN SEQUENCE

- 1) Set amplitude controls fully CCW.
- 2) Set OPERATE-STANDBY switch to the STANDBY position.
- 3) Turn off the prime power by pushing the POWER switch button.
- 4) Remove the laser diode from the output terminals.

TABLE OF CONTENTS

WARRANTY.....	2
CAUTION.....	3
TABLE OF CONTENTS	4
FIG. 1: MODEL AV-155A-C PULSE GENERATOR TEST ARRANGEMENT	5
GENERAL OPERATING INSTRUCTIONS	6
FIG. 2: FRONT PANEL CONTROLS	9
FRONT PANEL CONTROLS	10
FIG. 3: BACK PANEL CONTROLS	12
BACK PANEL CONTROLS	13
FIG. 4: POWER SUPPLY	14
FIG. 5: AV-155-PS -DUP3 BLOCK DIAGRAM.....	15
SYSTEM DESCRIPTION AND REPAIR	16
PERFORMANCE CHECK SHEET	17

FIG. 1: MODEL AV-155A-C PULSE GENERATOR TEST ARRANGEMENT

(RESISTIVE LOAD, NO DIODE)

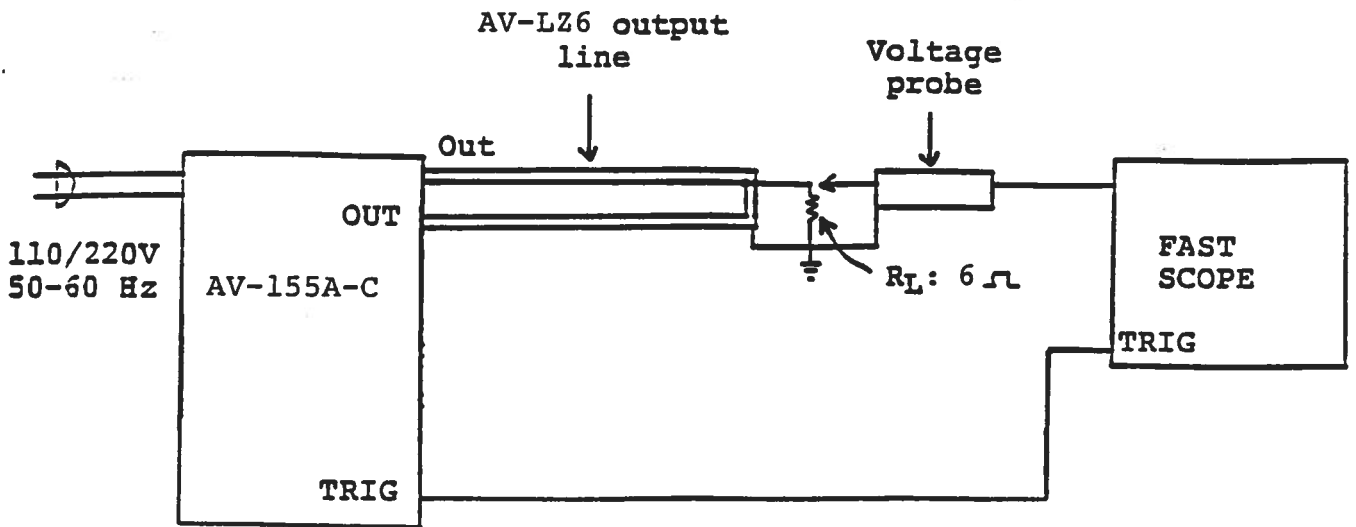

GENERAL OPERATING INSTRUCTIONS

- 1) The bandwidth capability of components and instruments used to display the pulse generator output signal (probes, cables, connectors, etc.) should exceed 100 MHz.
- 2) A low-inductance resistor should be used as the load. Note that an inductance of 50 nh will yield an inductance spike of about one Volt.
- 3) To control the unit via the internal clock, set the INT-EXTA-EXTB switch in the INT position. Set the PRF range switch in either position.
- 4) The output pulse width is controlled by means of the front panel one turn PW control and the X1-X10 range switch. The control should initially be set mid range and the pulse width adjusted using an oscilloscope.
- 5) The output pulse amplitude is controlled by means of the front panel one turn AMP control. Note that the load voltage range (i.e. compliance voltage) of the unit is 4 Volts so the load resistance must be sufficiently low (ideally six Ohm) so that the load voltage does not exceed 4 Volts.
- 6) The output DC bias is controlled by the front panel DC bias control. The polarity of the bias is always the same as the output pulse polarity.
- 7) The DELAY control controls the relative delay between the reference output pulse provided at the TRIG output and the main output. This delay is variable over the range of 0 to 200 ns.
- 8) A) The unit may also be triggered externally by setting the INT-EXTA-EXTB switch in either the EXTA or EXTB position and apply a trigger pulse the TRIG BNC.
B) When the switch is in the A position the unit operates as a voltage to current converter as follows:

$$I_{OUT} = 0.1 V_{IN}$$

Note that in this mode, the input amplitude should not exceed +2 Volts and also note that the PRF pulse width, amplitude and DC bias controls on the front panel are inactive.

C) When the switch is in the B position, the unit requires a TTL input trigger pulse (PW > 50 ns) and the output pulse width, amplitude and DC bias are

controlled by the front panel controls. The input trigger rate should not exceed 10 MHz as this may result in damage to the unit.

- 9) The diode load should be solder connected (as shown below) to the end of the AV-LZ6 flexible line which protrudes from the front panel.

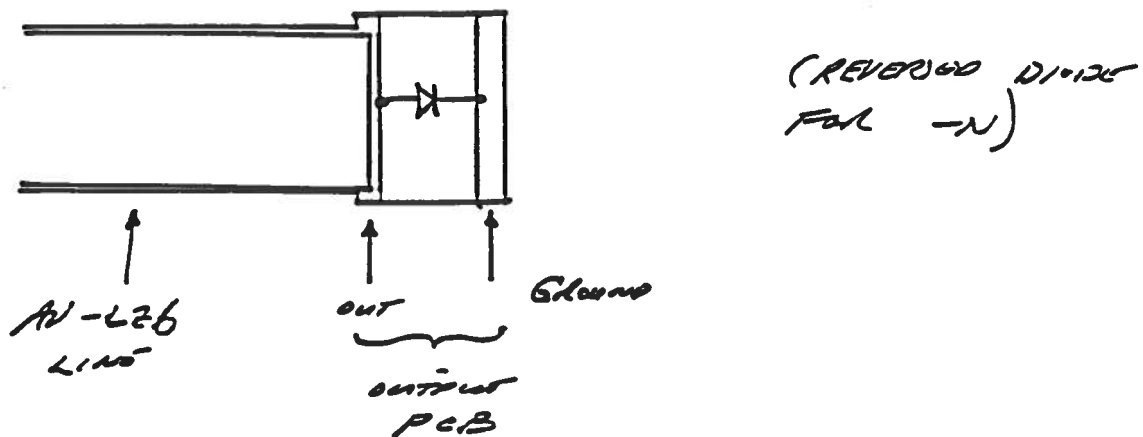

For units with the S5 option, the diode plugs directly into the socket provided.

- 10) The diode impedance should equal the characteristic impedance of the output line (6 Ohm). If the diode impedance is higher than six Ohm, the output rise time will be higher than 10 ns. This problem may be solved by replacing the AV-LZ6 line with a higher impedance version. The flexible output transmission line (AVTECH Model AV-LZ6) may be changed by desoldering the line from the 1/16" glass epoxy circuit board which protrudes from the -PG module. The -PG module is accessed by removing the four Phillips screws on the back panel of the instrument. The top cover will then slide back (and off), thereby exposing the -PG module.

- 11) If the diode impedance is less than six Ohm, the output waveform may exhibit severe overshoot. The addition of a small series resistor will serve to reduce the overshoot. Also if the diode has significant inductance (>10 nh) overshoot will be observed and for this reason the diode lead lengths must be extremely short (≤ 0.1 inches).
- 12) The unit can be converted from 100 to 220V 50-60 Hz operation by adjusting the voltage selector card in the rear panel fused voltage selector-cable connector assembly.
- 13) For additional assistance:

Tel: (613) 226-5772

Fax: (613) 226-2802

FIG. 2: FRONT PANEL CONTROLS

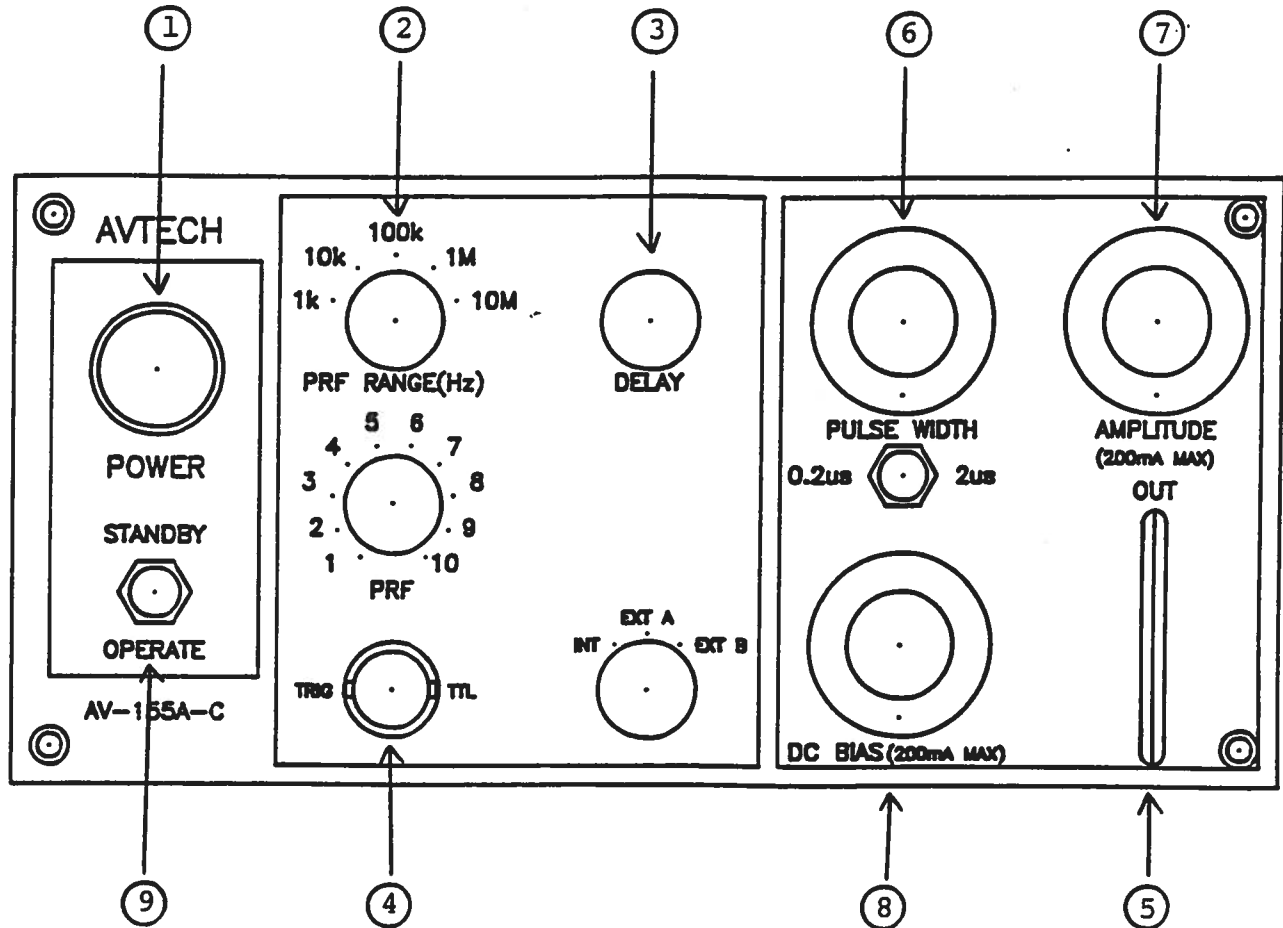

FRONT PANEL CONTROLS

- (1) ON-OFF Switch. Applies basic prime power to all stages.
- (2) PRF Control. Varies PRF from 100 Hz to 1 MHz as follows:

100 Hz to 1 kHz
 1 kHz to 10 kHz
 10 kHz to 100 kHz
 100 kHz to 1 MHz
 1 MHz to 10 MHz

- (3) DELAY Control. Controls the relative delay between the reference output pulse provided at the TRIG output (4) and the main output (5). This delay is variable over the range of 0 to about 200 ns.
- (4) TRIG. When the INT-EXTA-EXTB switch is in the INT position this output is used to trigger the scope time base. The output is a TTL level 20 ns (approx.) pulse capable of driving a fifty Ohm load. The external trigger signal is applied at this input when the toggle switch is in the EXTA or EXTB position. When the switch is in the A position the unit operates as a voltage to current converter as follows:

$$I_{OUT} = 0.1 V_{IN}$$

Note that in this mode, the input amplitude should not exceed +2 Volts and also note that the PRF, pulse width, amplitude and DC bias controls on the front panel are inactive.

When the switch is in the B position, the unit requires a TTL input trigger pulse (PW > 50 ns) and the output pulse width, amplitude and DC bias are controlled by the front panel controls. The input trigger rate should not exceed 10 MHz as this may result in damage to the unit.

- (5) OUT. 1 meter long AV-LZ6 flexible output line protrudes from the front panel. Diode load and series matching resistor to be solder connected to end of line. For units with -S5 option, diode plugs into the socket provided.
- (6) PULSE WIDTH. Varies output pulse width as follows (INT and EXTB MODE only):
- 20 ns to 200 ns
 200 ns to 2 us

- (7) PULSE AMPLITUDE. Ten turn amplitude control varies output pulse amplitude from 0 to 200 mA (INT and EXT B mode only).
- (8) DC BIAS AMPLITUDE. Ten turn offset control varies DC offset from 0 to 200 mA (INT and EXT B mode only).
- 9) STANDBY-OPERATE. When this switch is in the STANDBY position, a set of relay controls shorts out the laser diode whether the prime power is ON or OFF. When the switch is in the OPERATE position, the relay contacts open, provided the prime power is on. See the START UP and SHUT DOWN SEQUENCE notes preceding FIG 1. for a full discussion of the operation of this switch.

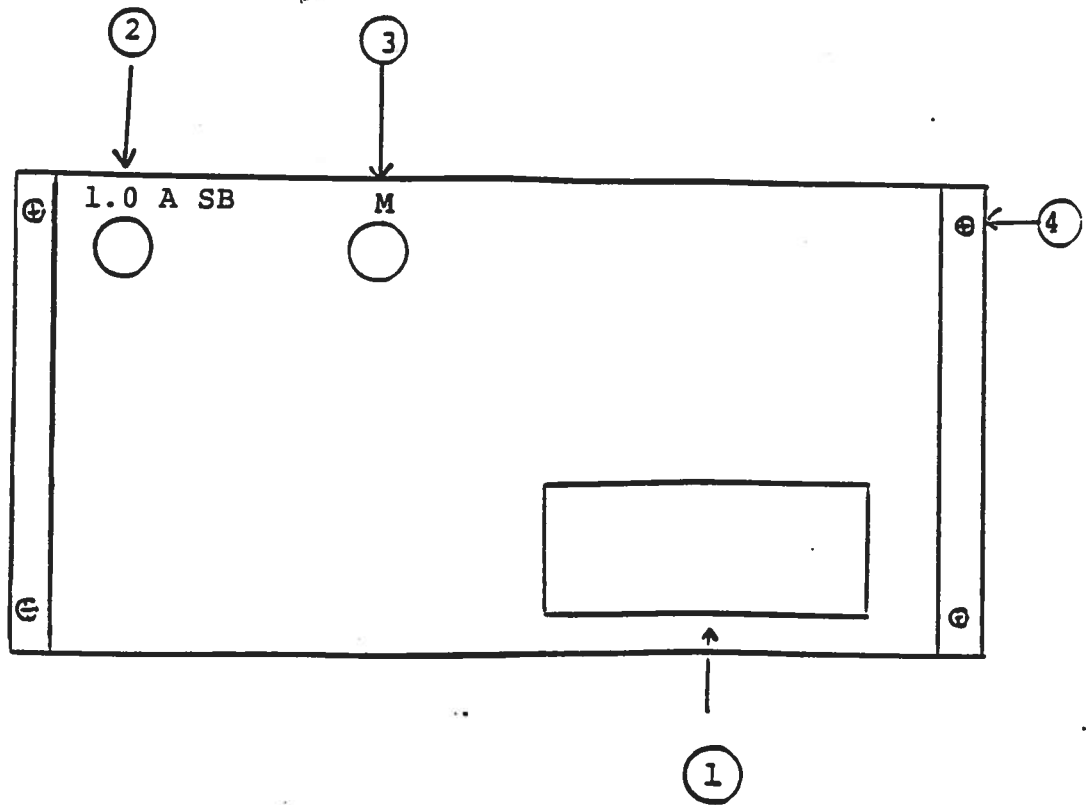
FIG. 3: BACK PANEL CONTROLS

BACK PANEL CONTROLS

- 1) Power Entry Module. Detachable line cord connects to this point. Also contains voltage selector card and line fuse (0.25 A SB).
- 2) 1.0 A SB Fuses. Limits current supplied to the output stages.
- 3) Monitor Option. BNC connector provides a coincident replica of the output pulse. For $R_L \geq 1K$.

$$I_{LOAD} = 0.05 V_M \text{ (Volts, Amp)}$$

For $R_L = 50 \text{ Ohm}$,

$$I_{LOAD} = 0.1 V_M \text{ (Volts, Amp)}$$

V_M is the monitor output Volt, amplitude is determined using a scope.

- 4) Cover Screws. To remove the top cover, remove the 4 Phillips screws and the top cover may then be slid back and off.

FIG. 4: POWER SUPPLY

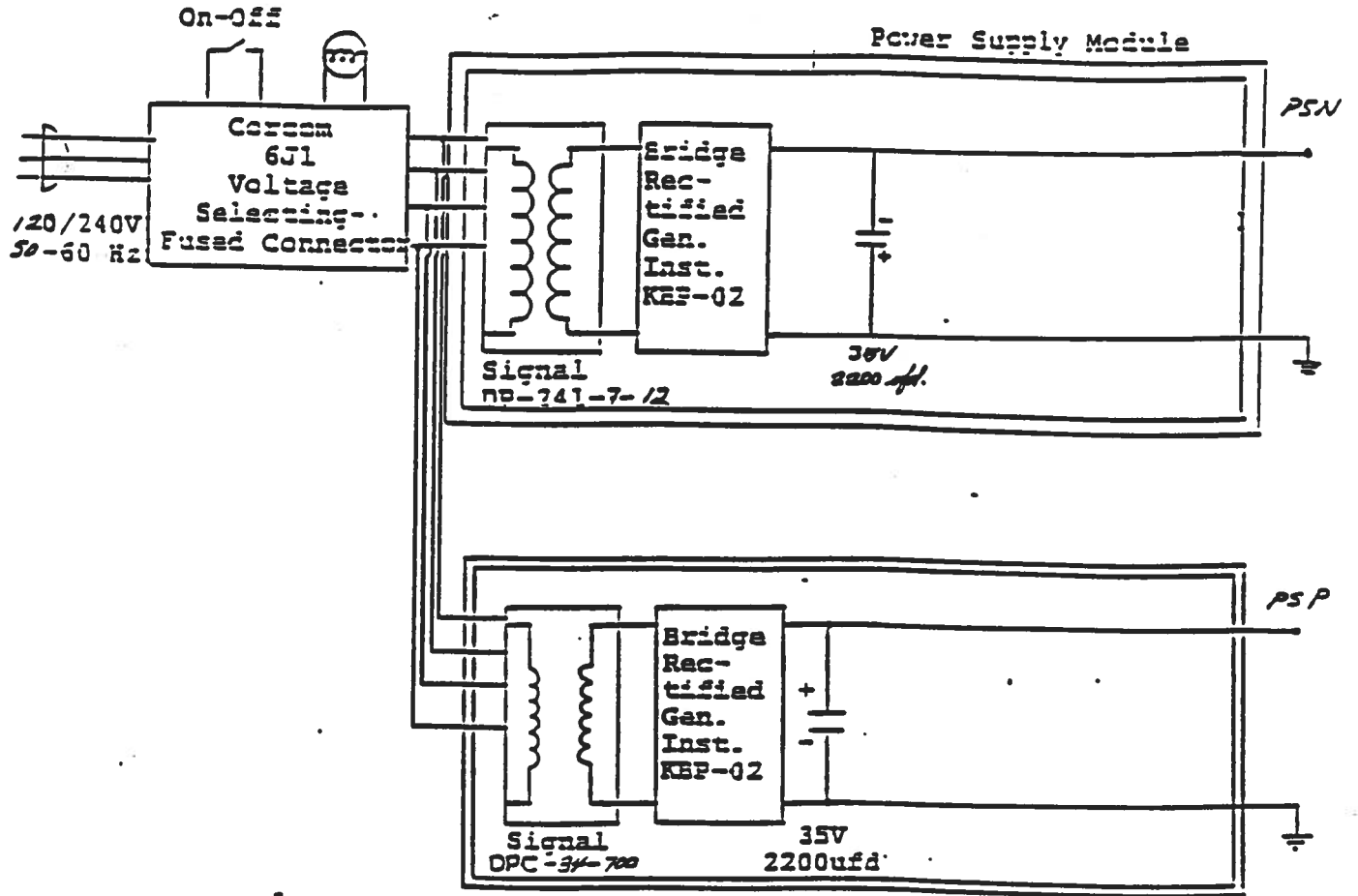
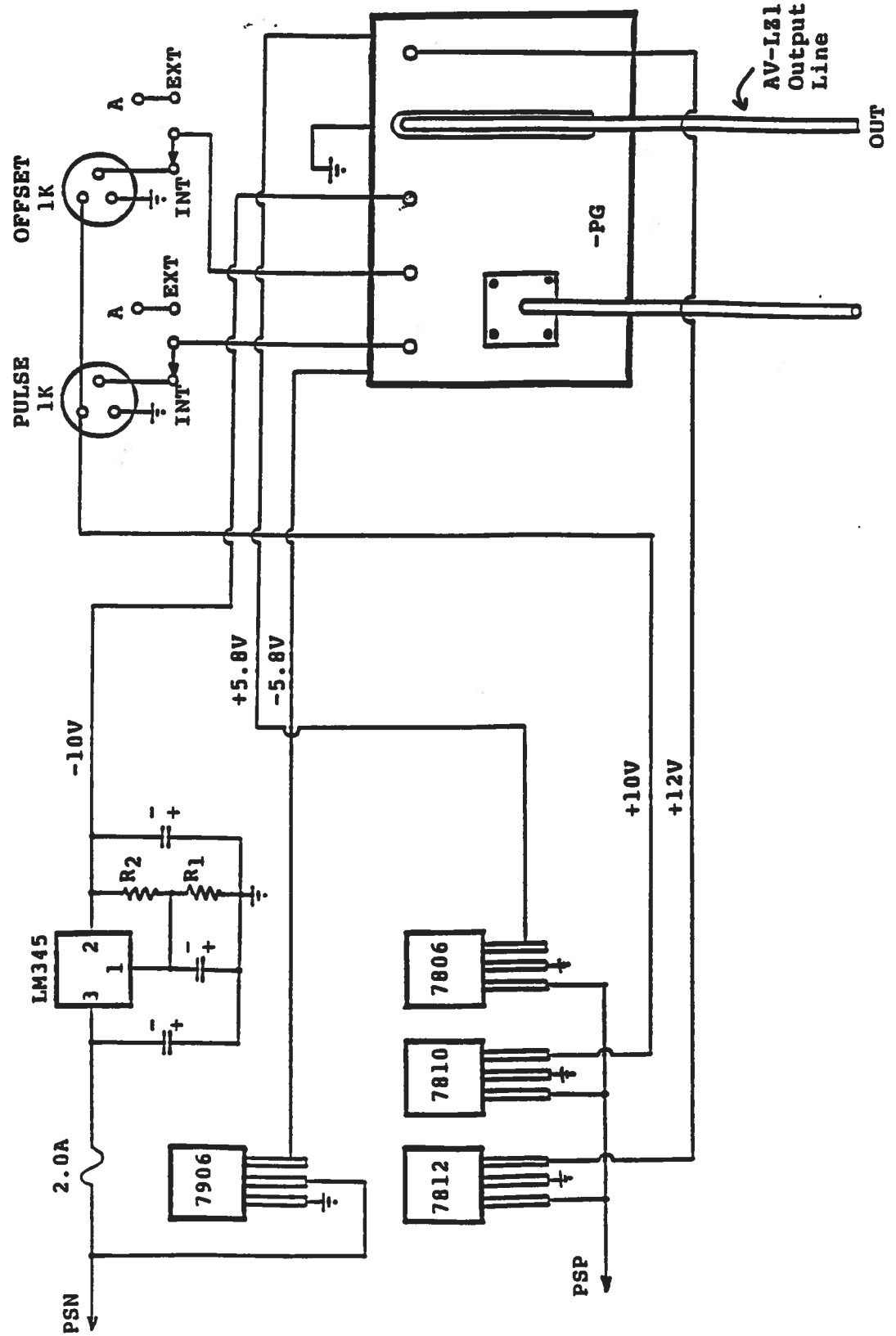

FIG. 5: AV-155-PS -DUP3 BLOCK DIAGRAM



SYSTEM DESCRIPTION AND REPAIR

Model AV-155A-C consists of a clock module (-CL2), a pulse generator module (AV-155A-PG) and a power supply which supplies -12V, -5.8V, +15V and +5.8 Volts to the modules. The power supply and block diagram are shown in Figs. 4 and 5.

If the instrument does not provide an output, check the line fuse and the 1.0 A SB fuses. If the fuses are not at fault, remove the top cover and check the -12V, -5.8V, +15V and +5.8 voltage levels. If the voltage levels are correct then the -PG module is defective. The sealed -PG module must then be returned to AVTECH for repair and replacement.

PERFORMANCE CHECK SHEET

May 17/95

\instructword\av155\av155A-C.doc

- M