



**AVTECH ELECTROSYSTEMS LTD.**

NANOSECOND WAVEFORM ELECTRONICS  
SINCE 1975

P.O. BOX 265  
OGDENSBURG, NY  
U.S.A. 13669-0265  
TEL: (315) 472-5270  
FAX: (613) 226-2802

TEL: 1-800-265-6681  
FAX: 1-800-561-1970  
U.S.A. & CANADA

e-mail: [info@avtechpulse.com](mailto:info@avtechpulse.com)

BOX 5120 STN. F  
OTTAWA, ONTARIO  
CANADA K2C 3H4  
TEL: (613) 226-5772  
FAX: (613) 226-2802

INSTRUCTIONS

MODEL AV-155A-N-PSA LASER DIODE DRIVER

S.N. :

### WARRANTY

Avtech Electrosystems Ltd. warrants products of its manufacture to be free from defects in material and workmanship under conditions of normal use. If, within one year after delivery to the original owner, and after prepaid return by the original owner, this Avtech product is found to be defective, Avtech shall at its option repair or replace said defective item. This warranty does not apply to units which have been disassembled, modified or subjected to conditions exceeding the applicable specifications or ratings. This warranty is the extent of the obligation or liability assumed by Avtech with respect to this product and no other warranty or guarantee is either expressed or implied.

Fig. 1

MODEL AV-155A LASER DIODE DRIVER TEST ARRANGEMENT

(1N5819 AND 1 OHM RESISTOR SIMULATING A LASER DIODE LOAD)

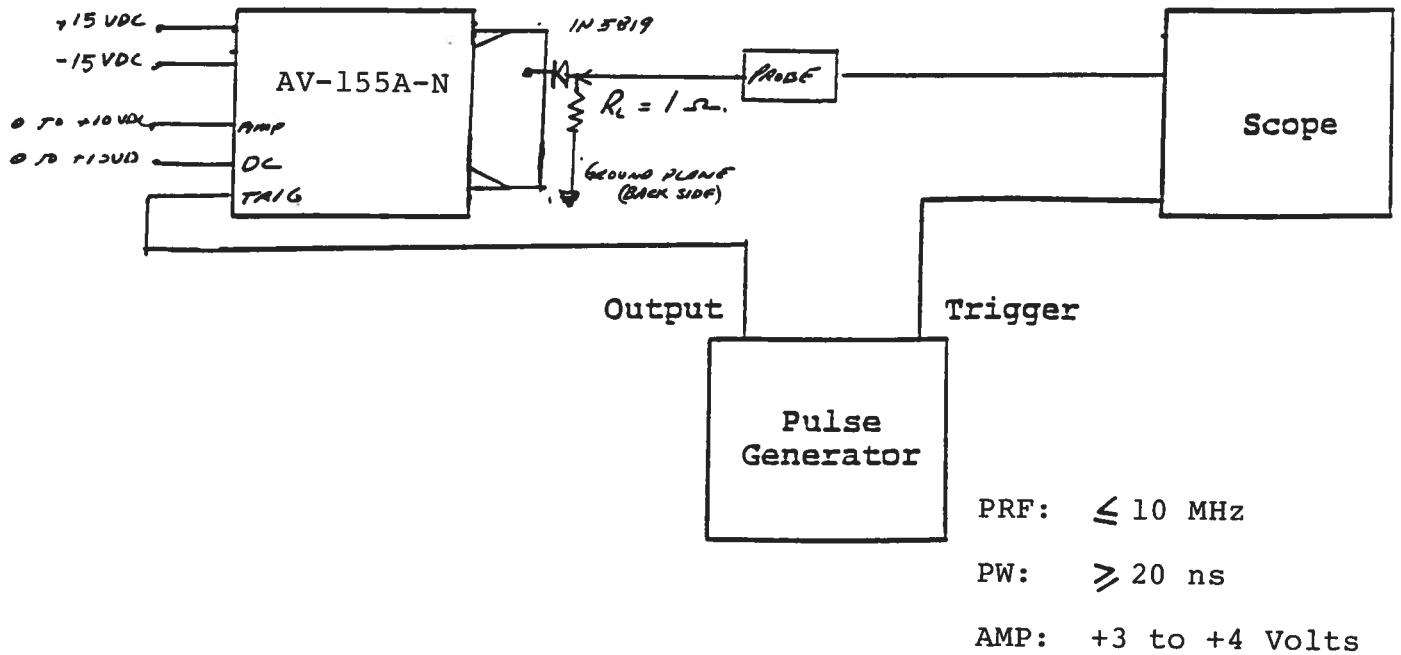

Notes:

- 1) The bandwidth capability of components and instruments used to display the pulse generator output signal (probes, cables, connectors, etc.) should exceed 100 MHz. It is recommended that 2N5819 diode and a 1 Ohm non inductive resistor be used as the load as shown in the drawing.
- 2) The TTL trigger signal controls the output PRF, PW and duty cycle when the unit is operated in MODE B. The input trigger signal also controls the output amplitude, pulse shape and offset when operating in MODE A.
- 3) **WARNING:** Model AV-155 may fail if triggered at a PRF greater than 10 MHz or if a non-TTL trigger signal is applied.
- 4) The output pulse width is equal to the input trigger pulse width and may be varied from 20 ns to DC.
- 5) When the AB switch is in the A position the unit operates as a voltage to current convertor:  
$$I_{OUT} = -0.1 V_{IN} \quad (V_{IN} \leq 4.0 \text{ Volts})$$
- 6) To voltage control the output pulse amplitude, set the rear panel switch in the B position, and apply 0 to +10 V between the AMP terminal and ground ( $R_{IN} \geq 10K$ ). In this mode, the unit requires a TTL level trigger signal.
- 7) The output offset may be voltage controlled (from 0 to -400 mA) applying 0 to +10 V between the DC terminal and ground ( $R_{IN} \geq 10K$ ). (For both MODE A and MODE B).
- 8) **MONITOR OUT.** The SMA "M" output connector adjacent to the output terminal provides a voltage waveform replica of the output current waveform as follows (pulse and offset):

$$R_L \geq 1K:$$

$$I_{OUT} = 200 V_{MON} \quad (\text{Volts, mA})$$

$$R_L = 50 \text{ Ohms:}$$

$$I_{OUT} = 400 V_{MON} \quad (\text{Volts, mA})$$

- 9) A low-inductance resistor should be used as the test load. Note that an inductance of 10 nh will yield an inductance spike of about one Volt. With a low-inductance one Ohm load, the overshoot may be as high as 10%. The overshoot will significantly decrease as the load resistance is increased to 2 or 3 Ohms.
- 10) The module must be bolted to a heatsink capable of dissipating about 10 Watts. It is also recommended that a heat sink be attached to the copper tab protruding from the top surface of the module.
- 11) Two ten turn trim pots are provided (on the input end of the chassis). The pot nearest the chassis end is used to zero the output DC offset when the amplitude control voltage is set to zero. The other pot may be used to control base line shift as the output pulse amplitude is increased. Both pots were adjusted at the time of shipping and so should not require further adjustments.
- 12) When connecting a laser diode load, it is recommended that a 1N5819 diode be placed across the laser diode to protect against reverse potentials; i.e. the anode of the 1N5819 should contact the cathode of the laser diode (while the cathode should contact the anode).
- 13) When operating in MODE A (i.e. voltage to current converter) and employing a sinusoidal modulation input voltage, take care to first apply a DC offset to the load (via the DC terminal) to insure that the net load current does not become positive.
- 14) For additional assistance:

Tel: (613) 226-5772  
Fax: (613) 226-2802

June 4/97

Disk: AV-150

Name: 155ANPSA.INS