



AVTECH ELECTROSYSTEMS LTD.

NANOSECOND WAVEFORM ELECTRONICS
SINCE 1975

□ P.O. BOX 265
OGDENSBURG, NY
U.S.A. 13669-0265
TEL: (315) 472-5270
FAX: (613) 226-2802

TEL: 1-800-265-6681
FAX: 1-800-561-1970
U.S.A. & CANADA

□ BOX 5120 STN. F
OTTAWA, ONTARIO
CANADA K2C 3H4
TEL: (613) 226-5772
FAX: (613) 226-2802

INSTRUCTIONS

MODEL AV-155A-PS-CMUA PULSE GENERATOR

S.N. :

WARRANTY

Avtech Electrosystems Ltd. warrants products of its manufacture to be free from defects in material and workmanship under conditions of normal use. If, within one year after delivery to the original owner, and after prepaid return by the original owner, this Avtech product is found to be defective, Avtech shall at its option repair or replace said defective item. This warranty does not apply to units which have been disassembled, modified or subjected to conditions exceeding the applicable specifications or ratings. This warranty is the extent of the obligation or liability assumed by Avtech with respect to this product and no other warranty or guarantee is either expressed or implied.

Fig. 1

MODEL AV-155 A-PS-CMU PULSE GENERATOR TEST ARRANGEMENT

(RESISTIVE LOAD, NO DIODE)

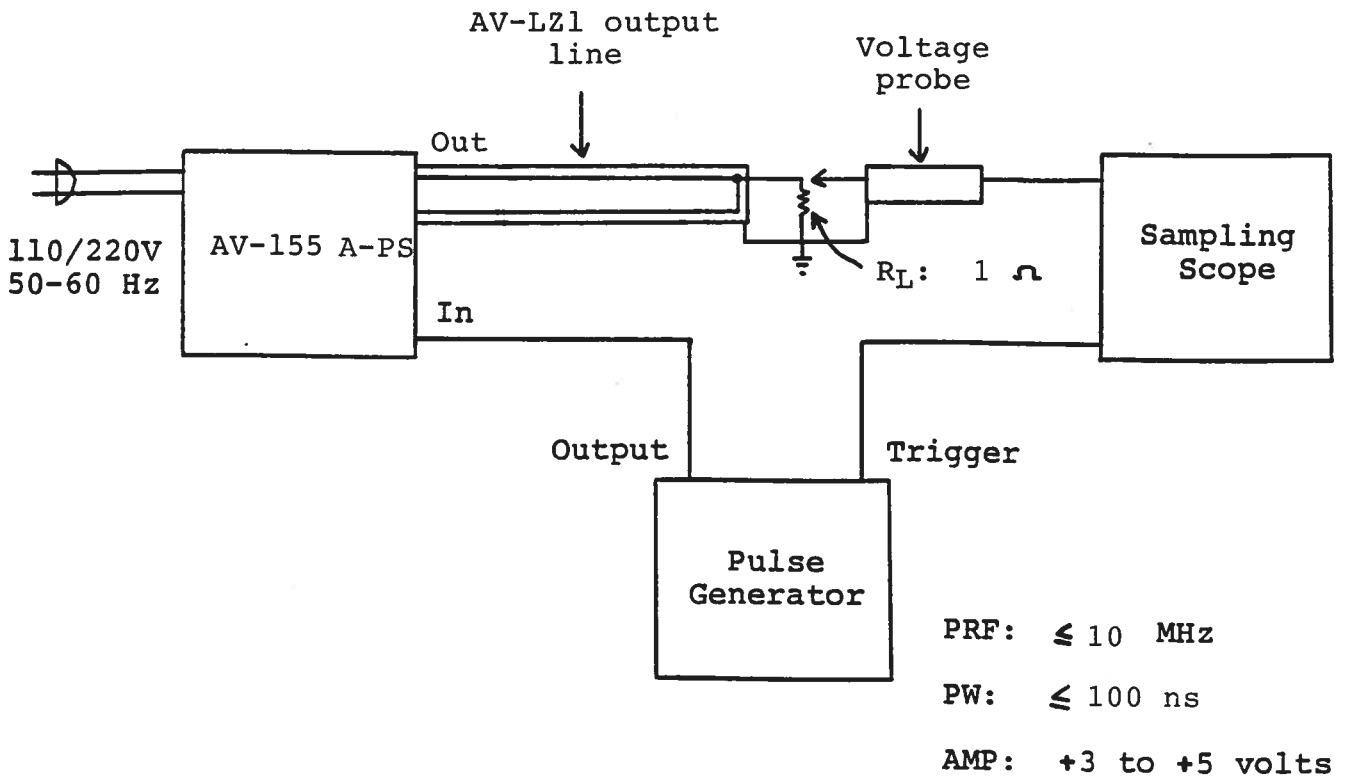

Notes:

- 1) The bandwidth capability of components and instruments used to display the pulse generator output signal (probes, cables, connectors, etc.) should exceed 100 MHz.
- 2) When the MODE AB switch is in the A position the unit operates as a voltage to current converter as follows:

$$I_{OUT} = 0.05 V_{IN}$$

Note that in this mode, the input amplitude should not exceed +4 Volts and also note that the pulse width, amplitude and DC bias controls on the front panel are inactive.

- 3) When the MODE AB switch is in the B position, the unit requires a TTL input trigger pulse (PW > 50 ns) and the output pulse width, amplitude and DC bias are controlled by the front panel controls as follows:

PW: 20 ns to 200 ns
200 ns to 2.0 us
AMP: 0 to +200 mA
BIAS: 0 to +200 mA

- 4) The input trigger rate should not exceed 10 MHz as this may result in damage to the unit.
- 5) The diode load should be solder connected (as shown below) to the end of the AV-LZ1 flexible line which protrudes from the front panel.

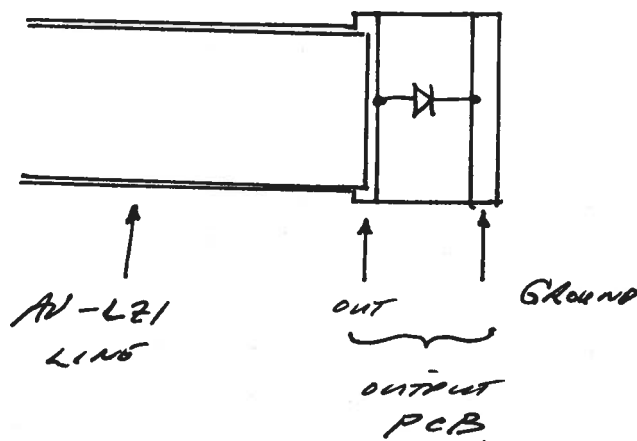

- 6) The diode impedance should equal the characteristic impedance of the output line (1 Ohm). If the diode impedance is higher than one Ohm, the output rise time will be higher than 10 ns. This problem may be solved by replacing the AV-LZ1 line with a higher impedance version. The flexible output transmission line (AVTECH Model AV-LZ1) may be changed by desoldering the line from the 1/16" glass epoxy circuit board which protrudes from the -PG module. The -PG module is accessed by removing the four Phillips screws on the back panel of the instrument. The top cover will then slide back (and off), thereby exposing the -PG module.
- 7) If the diode impedance is less than one Ohm, the output waveform may exhibit severe overshoot. Also if the diode has significant inductance (>10 nh) overshoot will be observed and for this reason the diode lead lengths must be extremely short (≤ 0.1 inches).
- 8) A DC control signal (0 to +1.0 Volt) may be applied to the rear panel ERROR IN solder terminal. A +1.0 Volt signal will decrease the output pulse amplitude by 100 mA.
- 9) The AV-155-PS unit can be converted from 110 to 220V 50-60 Hz operation by adjusting the voltage selector card in the rear panel fused voltage selector-cable connector assembly.
- 10) For additional assistance:

Tel: 1-800-265-6681

Fax: (613)226-2802

Fig. 2

FRONT PANEL CONTROLS

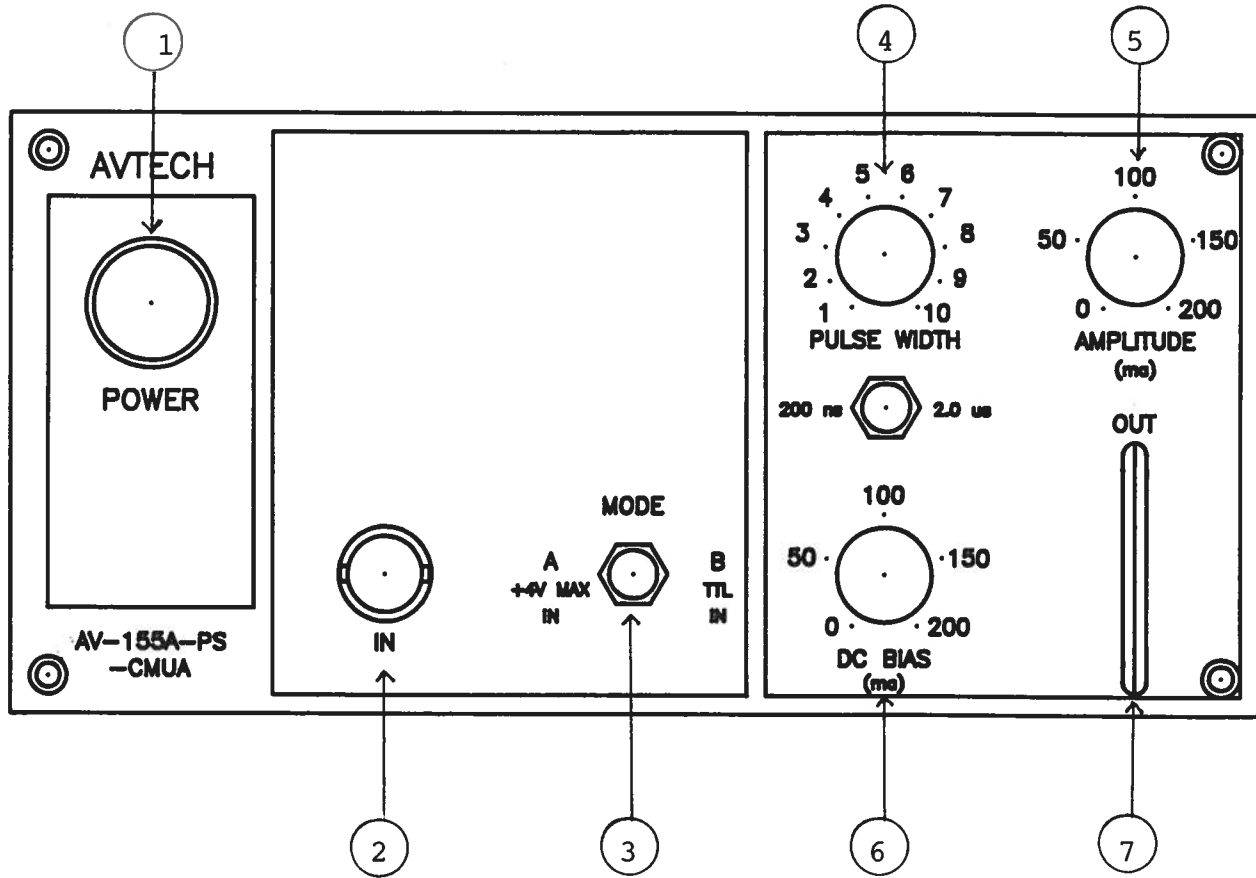

FRONT PANEL CONTROLS

- 1) POWER SWITCH. Applies power to all stages.
- 2) IN BNC. When the MODE AB switch
- 3) is in the A position, the unit operates as a voltage to current converter. ($I_{OUT} = 0.05 V_{IN}$). The front panel PW, AMP and DC lines controls are inactive. When the MODE AB switch is in the B position, the unit requires a +3 to +5 Volt trigger pulse ($PW \geq 50$ ns). The PW, AMP and DC lines controls are active on this mode.
- 4) PULSE WIDTH. Varies output pulse width as follows (B MODE only):
20 to 200 ns
200 ns to 2.0 us
- 5) PULSE AMPLITUDE. One turn amplitude control varies output pulse amplitude from 0 to +200 mA (B MODE only).
- 6) DC BIAS AMPLITUDE. One turn offset control varies DC offset from 0 +200 mA (B MODE only).
- 7) OUT. 1 meter long AV-LZ1 flexible output line protrudes from the front panel. Diode load and series matching resistor to be solder connected to end of line.

Fig. 3

BACK PANEL CONTROLS

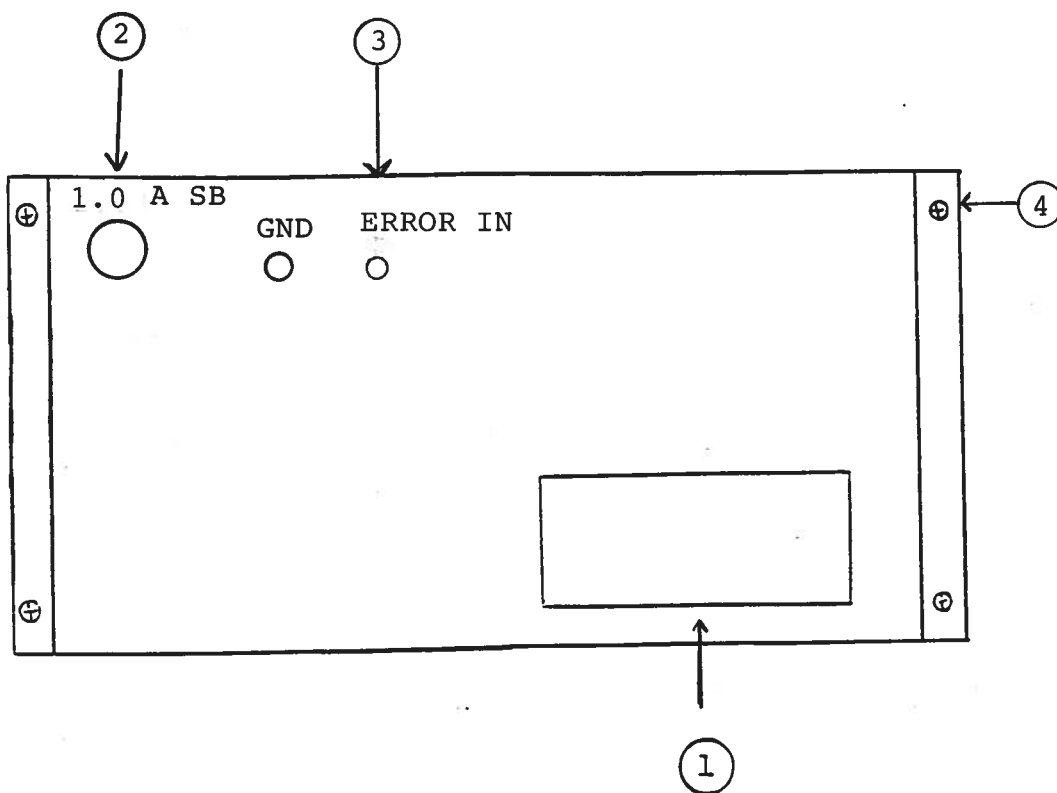

BACK PANEL CONTROLS

- 1) Power Entry Module. Detachable line cord connects to this point. Also contains voltage selector card and line fuse (0.25 A SB).
- 2) 1.0 A SB Fuse. Limits current supplied to the output stage.
- 3) Error In. Application of the 0 to +1.0 VDC control voltage to this solder terminal causes the pulse out amplitude to decrease by 0 to 100 mA. ($R_{IN} \geq 5 \text{ K}$).
- 4) Cover Screws. To remove the top cover, remove the 4 Phillips screws and the top cover may then be slid back and off.

Fig. 4

POWER SUPPLY

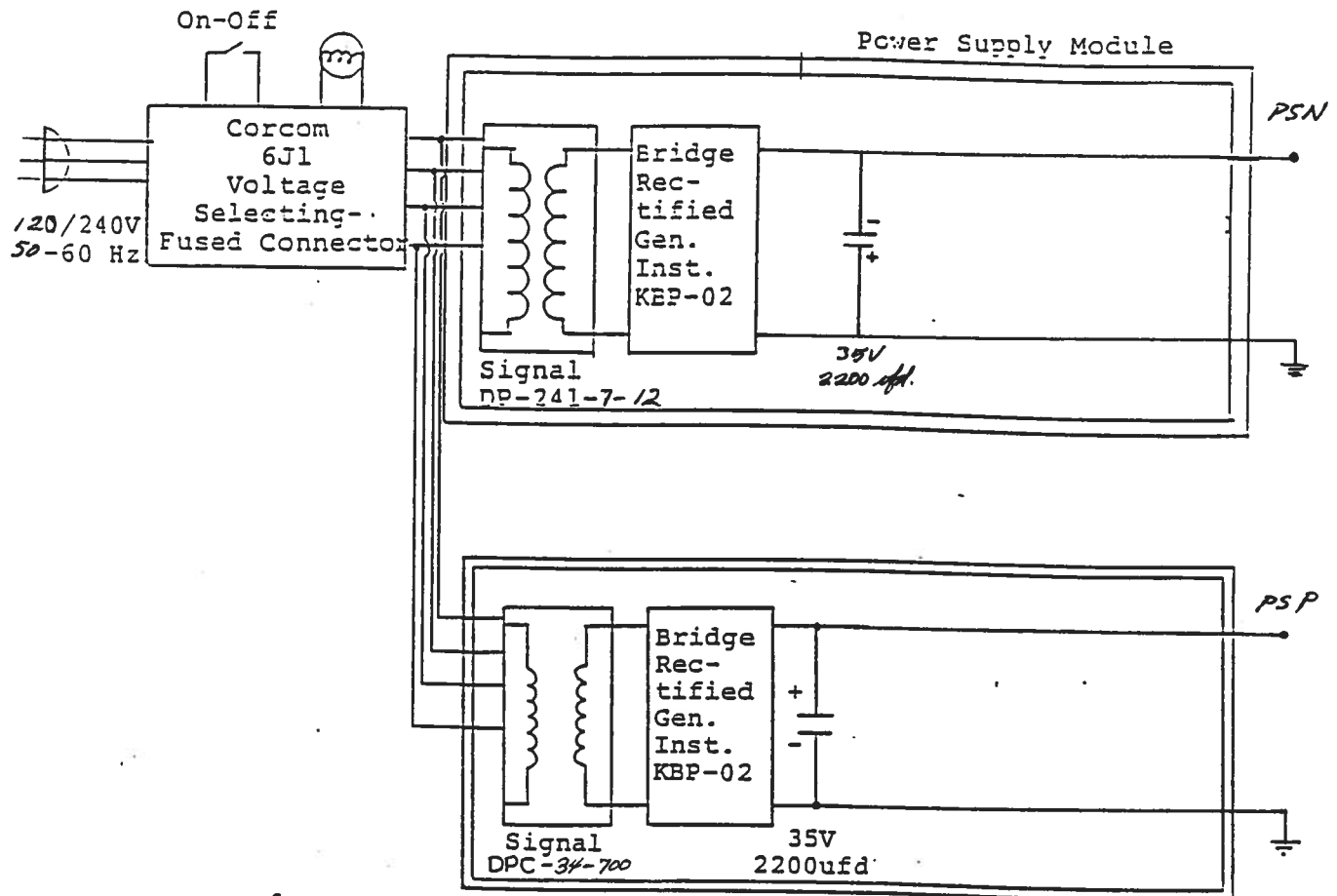

SYSTEM DESCRIPTION AND REPAIR PROCEDURE

Model AV-155-PS-CMUA consists of a pulse generator module (AV-155-CMUA-PG-N) and a power supply which supplies -10V, -5.8V, +12V and +5.8 Volts to the module. The power supply and block diagram are shown in Figs. 4 and 5.

If the instrument does not provide an output, check the line fuse and the 1.0 A SB fuse. If the fuses are not at fault, remove the top cover and check the -10V, -5.8V, +12V and +5.8 voltage level. If the voltage levels are correct then the -PG module is defective. The sealed -PG module must then be returned to AVTECH for repair and replacement.

May 10/94

THE UNIVERSITY OF CHICAGO

Department of Chemistry
5780 South Ellis Avenue
Chicago, Illinois 60637

Dear _____
I am pleased to inform you that your application for admission to the M.S. program in Chemistry for the fall semester has been accepted. You will be joining a group of students who are pursuing their graduate studies in our department. We are confident that you will find the environment here to be both stimulating and rewarding. Please contact me at the above address if you have any questions.

Sincerely,
