



AVTECH ELECTROSYSTEMS LTD.

NANOSECOND WAVEFORM ELECTRONICS
SINCE 1975

□ P.O. BOX 265
OGDENSBURG, NY
U.S.A. 13669-0265
TEL: (315) 472-5270
FAX: (613) 226-2802

TEL: 1-800-265-6681
FAX: 1-800-561-1970

e-mail: info@avtechpulse.com
<http://www.avtechpulse.com>

□ P.O. BOX 5120 STN. F
OTTAWA, ONTARIO
CANADA K2C 3H4
TEL: (613) 226-5772
FAX: (613) 226-2802

INSTRUCTIONS

MODEL AV-155B-B

**0 to 800 mA AMPLITUDE, 0 to 200 mA OFFSET,
0 to 4V COMPLIANCE, 50 ns RISE TIME**

PULSED CONSTANT CURRENT GENERATOR

WITH IEEE 488.2 AND RS-232 CONTROL

SERIAL NUMBER: _____

WARRANTY

Avtech Electrosystems Ltd. warrants products of its manufacture to be free from defects in material and workmanship under conditions of normal use. If, within one year after delivery to the original owner, and after prepaid return by the original owner, this Avtech product is found to be defective, Avtech shall at its option repair or replace said defective item. This warranty does not apply to units which have been disassembled, modified or subjected to conditions exceeding the applicable specifications or ratings. This warranty is the extent of the obligation assumed by Avtech with respect to this product and no other warranty or guarantee is either expressed or implied.

TECHNICAL SUPPORT

Phone: 613-226-5772 or 1-800-265-6681

Fax: 613-226-2802 or 1-800-561-1970

E-mail: info@avtechpulse.com

World Wide Web: <http://www.avtechpulse.com>

TABLE OF CONTENTS

WARRANTY	2
TECHNICAL SUPPORT	2
TABLE OF CONTENTS	3
INTRODUCTION	5
SPECIFICATIONS	6
INSTALLATION	7
VISUAL CHECK	7
PLUGGING IN THE INSTRUMENT	7
LABVIEW DRIVERS	7
FRONT PANEL CONTROLS	8
REAR PANEL CONTROLS	10
GENERAL INFORMATION - PULSE GENERATOR OPERATION	12
BASIC PULSE TIMING CONTROL	12
Internal Triggering	12
External Triggering, with Normal PW and Amplitude Modes	13
External Triggering, with $PW_{IN}=PW_{OUT}$ mode and Normal Amplitude Mode	14
External Amplitude Mode	14
Amplifier Mode (Voltage-to-Current Converter)	15
TRIGGER MODES	15
GATING MODES	16
CONNECTING THE LOAD FOR OPTIMUM PERFORMANCE	17
USING THE SUPPLIED CABLES	17
ADDING A SERIES RESISTANCE	18
LOAD AND INSTRUMENT PROTECTION	19
PROTECTING DIODE LOADS	19
LENZ'S LAW AND INDUCTIVE VOLTAGE SPIKES	19
OUTPUT ON/OFF	19
ATTACHING AND DETACHING LOADS	19
OPEN AND SHORT CIRCUITS	20
OPERATIONAL CHECK	21
CALIBRATION ADJUSTMENTS - INTERNAL TRIMPOTS	24
NULLING CONSTANT CURRENT OFFSETS	24
NULLING AMPLITUDE-DEPENDENT CURRENT OFFSETS	25
NULLING CONSTANT MONITOR OFFSETS	25
ADJUSTING OUTPUT IMPEDANCE	25

	4
ADJUSTING MONITOR CALIBRATION	25
<i>CALIBRATION ADJUSTMENTS - SOFTWARE PROCEDURES</i>	26
ADJUSTING AMPLITUDE ACCURACY	26
<i>MECHANICAL INFORMATION</i>	27
TOP COVER REMOVAL	27
RACK MOUNTING	27
<i>PROGRAMMING YOUR PULSE GENERATOR</i>	28
KEY PROGRAMMING COMMANDS	28
ALL PROGRAMMING COMMANDS	29
<i>PERFORMANCE CHECK SHEET</i>	31

Manual Reference: Q:\office\instructword\Av-155\AV-155B-B.doc, created June 22, 2000

INTRODUCTION

The Model AV-155B-B pulsed constant current generator is capable of producing pulses with amplitudes as high as 800 mA into load voltages up to 4V, with 50 ns rise and fall times. A DC offset in the range of 0 to 200 mA may be added to the pulse output. The current and voltage polarities depend on the model number:

"-P" units: 0 to +800 mA amplitude, 0 to +200 mA offset, 0 to +4V compliance

"-N" units: 0 to -800 mA amplitude, 0 to -200 mA offset, 0 to -4V compliance

"-PN" units: 0 to ± 800 mA amplitude, 0 to ± 200 mA offset, -4V to +4V compliance

The internal trigger source can be used to trigger the instrument at frequencies between 1 Hz and 10 MHz. An external TTL trigger pulse, a front-panel pushbutton, and a computer can also be used to trigger the instrument.

The external trigger function offers considerable flexibility. Several modes are available:

- Voltage-to-current amplifier mode. In this case, the output signal $I_{OUT} \approx V_{AMP} \times 200$ mA/V, and the output current waveform tracks the input voltage waveform. The output follows the input by a minimal fixed delay.
- $PW_{OUT} = PW_{IN}$ mode. The output pulse width tracks the input pulse width, but the amplitude is controlled by the front panel settings (or by programming commands). The output follows the input by a minimal fixed delay. The external trigger is TTL-level.
- Normal external trigger mode. The output pulse width and amplitude are controlled by the front panel settings (or by programming commands). The output follows the input by a programmable delay. The external trigger is TTL-level.
- In the latter two modes, the output amplitude can also be set to track a DC voltage (0 to 10V full-scale) present on the rear-panel "AMP" connector. (This optional feature is only present on units with the "-EA" model number suffix.)

The Model AV-155B-B pulse generator is a current pulser. The current amplitude is largely independent of the load voltage. For proper operation, the load voltage ($V_{LOAD} = I_{LOAD} \times R_{LOAD}$) must not exceed 4V.

The AV-155B-B features front panel keyboard and adjust knob control of the output pulse parameters along with a four line by 40 character back-lit LCD display of the output amplitude, pulse width, pulse repetition frequency, and delay. The instrument includes memory to store up to four complete instrument setups. The operator may use the front panel or the computer interface to store a complete "snapshot" of all key instrument settings, and recall this setup at a later time.

LabView drivers for this instrument may be downloaded from the Avtech website, at <http://www.avtechpulse.com/labview/>.

SPECIFICATIONS

Model:	AV-155B-B
Amplitude:	
"-P" units:	Pulse: 0 to +800 mA, DC Offset: 0 to +200 mA, Peak: +1000 mA, for load voltages of 0 to +4 Volts
"-N" units:	Pulse: 0 to -800 mA, DC Offset: 0 to -200 mA, Peak: -1000 mA, for load voltages of 0 to -4 Volts
"-PN" units:	Pulse: 0 to ± 800 mA, DC Offset: 0 to ± 200 mA, Peak: ± 1000 mA, for load voltages of -4 to +4 Volts
Pulse width:	100 ns to 1 s
Rise time:	≤ 10 ns
Fall time:	≤ 10 ns
PRF:	internal trigger: 1 Hz to 10 MHz external or pushbutton trigger: 0 to 10 MHz
Max. duty cycle:	Internal trigger: 90% External trigger: 100%
Output current regulation:	$\leq 1\%$ for load change from 0V to 4V
Trigger required: (external trigger mode)	50 ns or wider (TTL)
Monitor output:	Provides an attenuated coincident replica of the main output current pulse. $V_{MON} \cong I_{LOAD} \times 1 \Omega$
Sync delay:	0 to 1 s
Sync output:	+ 3 Volts, 50 ns wide, will drive 50 Ohm loads
Connectors:	Out: LZ1 socket, Gate, Trig, Sync, Monitor: BNC
Power, AC:	120/240 Volts (switchable) 50 - 60 Hz
Dimensions:	3.9" x 17" x 14.8"
Chassis material:	anodized aluminum, with blue plastic trim
Mounting:	Any
Temperature range:	+ 10° to + 40° C
LabView driver:	Available at http://www.avtechpulse.com/labview/

INSTALLATION

VISUAL CHECK

After unpacking the instrument, examine to ensure that it has not been damaged in shipment. Visually inspect all connectors, knobs, liquid crystal displays (LCDs), and the handles. Confirm that a power cord and two instrumentation manuals (this manual and the "OP1B Interface Programming Manual") are with the instrument. If the instrument has been damaged, file a claim immediately with the company that transported the instrument.

PLUGGING IN THE INSTRUMENT

Examine the rear of the instrument. There will be a male power receptacle, a fuse holder and the edge of the power selector card visible. Confirm that the power selector is in the correct orientation - it should be marked either 120 or 240, indicating whether it expects 120V AC or 240V AC. If it is not set for the proper voltage, remove the fuse and then grasp the card with a pair of pliers and remove it. Rotate horizontally through 180 degrees. Reinstall the card and the correct fuse. In the 120V setting, a 1A slow blow fuse is required. In the 240V setting, a 1/2A slow blow fuse is required.

LABVIEW DRIVERS

LabView drivers for this instrument may be downloaded from the Avtech website, at <http://www.avtechpulse.com/labview/>.

FRONT PANEL CONTROLS

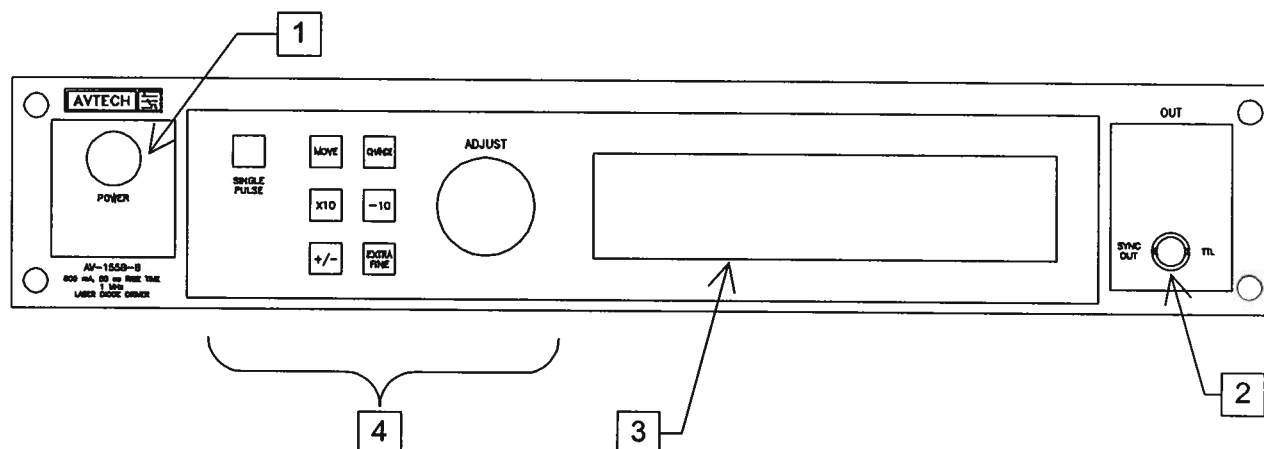

1. **POWER Switch.** The POWER push button switch applies AC prime power to the primaries of the transformer, turning the instrument on. The push button lamp (#382 type) is connected to the +15V DC supply.
2. **SYNC OUT.** This connector supplies a SYNC output that can be used to trigger other equipment, particularly oscilloscopes. The sync output has an approximate amplitude of +3 Volts to $R_L > 1K$ with a pulse width of approximately 50 ns.
3. **LIQUID CRYSTAL DISPLAY (LCD).** This LCD is used in conjunction with the keypad to change the instrument settings. Normally, the main menu is displayed, which lists the key adjustable parameters and their current values. The "OP1B Interface Programming Manual" describes the menus and submenus in detail.
4. **KEYPAD.**

Control Name	Function
MOVE	This moves the arrow pointer on the display.
CHANGE	This is used to enter the submenu, or to select the operating mode, pointed to by the arrow pointer.
×10	If one of the adjustable numeric parameters is displayed, this increases the setting by a factor of ten.
÷10	If one of the adjustable numeric parameters is displayed, this decreases the setting by a factor of ten.
+/-	If one of the adjustable numeric parameters is displayed, and this parameter can be both positive or negative, this changes the sign of the parameter.
EXTRA FINE	This changes the step size of the ADJUST knob. In the extra-fine mode, the step size is twenty times finer than in the normal mode. This button switches between the two step sizes.
ADJUST	This large knob adjusts the value of any displayed numeric adjustable values, such as frequency, pulse width, etc. The

	<p>adjust step size is set by the "EXTRA FINE" button.</p>
--	--

	<p>When the main menu is displayed, this knob can be used to move the arrow pointer.</p>
--	--

REAR PANEL CONTROLS

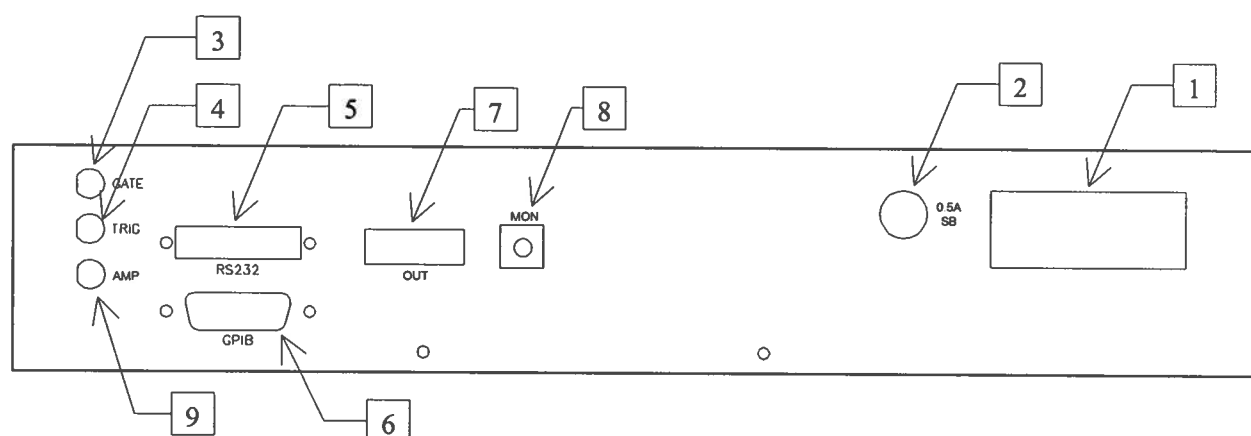

1. **AC POWER INPUT.** A three-pronged recessed male connector is provided on the back panel for AC power connection to the instrument. Also contained in this assembly is a 1A slow blow fuse and a removable card that can be removed and repositioned to switch between 120V AC in and 240V AC in.
2. **1.5A SB.** This fuse protects the internal DC power supplies. (Separate fuses may be present for positive and negative supplies.)
3. **GATE.** This TTL-level (0 and +5V) logic input can be used to gate the triggering of the instrument. This input can be either active high or active low, depending on the front panel settings or programming commands. (The instrument triggers normally when this input is unconnected).
4. **TRIG.** This TTL-level (0 and +5V) logic input can be used to trigger the instrument, if the instrument is set to triggering externally. The instrument triggers on the rising edge of this input.
5. **RS-232 Connector.** A standard serial cable with a 25-pin male connector can be attached to this connector to allow the instrument to be computer-controlled. See the "OP1B Interface Programming Manual" for more details on RS-232 control.
6. **GPIB Connector.** A standard GPIB cable can be attached to this connector to allow the instrument to be computer-controlled. See the "OP1B Interface Programming Manual" for more details on GPIB control.
7. **OUT.** This is the main output. The LZ1 transmission line or the RG174 transmission line plugs into this socket. The upper side of the socket ("UP") is the signal line. The lower side ("DOWN") is connected to ground.
8. **MON.** This is the current monitor output. This output provides a voltage waveform that is proportional to the current waveform on the main output. The monitor relationship is approximately: $V_{MON1} \cong 1\Omega \times I_{OUT1}$, for a load of $> 1\text{ k}\Omega$. (The monitor

output can also drive a 50Ω load, but the output voltage will be reduced by a factor of two. This output is short-circuit protected.)

9. AMP. When the amplitude is set to the "EXT AMPLIFY" mode (i.e., the instrument is in the voltage-to-current converter mode), the output current is approximately equal to $I_{OUT} = V_{AMP} \times 0.2 \text{ A/V}$, where V_{AMP} is the signal on this connector.

For instruments with the "-EA" model number suffix: When the amplitude is set to the "EXT CONTROL" mode, the output current is amplitude is controlled by the DC voltage on this connector, with 0V corresponding to zero output, and 10V corresponding to full-scale output.

GENERAL INFORMATION - PULSE GENERATOR OPERATION

BASIC PULSE TIMING CONTROL

This instrument can be triggered by several sources - its own internal clock, an external TTL trigger signal, the front-panel "SINGLE PULSE" pushbutton, or by a computer-generated command. In any case, three output channels respond to the trigger: OUT, SYNC, and MON. The OUT channel is the signal that is applied to the load. Its amplitude and pulse width are variable. The SYNC pulse is a fixed-width TTL-level reference pulse used to trigger oscilloscopes or other measurement systems. When the delay is set to a positive value the SYNC pulse precedes the OUT pulse. When the delay is set to a negative value the SYNC pulse follows the OUT pulse. The MON output is a voltage waveform that is proportional to the current waveform on OUT. $V_{MON} = I_{OUT} \times 1\Omega$, for monitor loads of $> 1\text{ k}\Omega$.

The different trigger modes are detailed below. In all cases, positive amplitude and offset is assumed.

Internal Triggering

These pulses are illustrated below for a positive delay, and internal triggering:

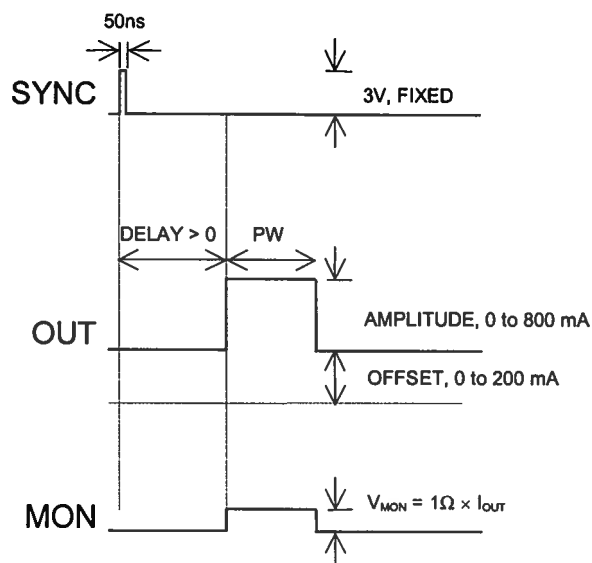

Basic Output Pulses for Delay > 0

The order of the output pulses is reversed for negative delays:

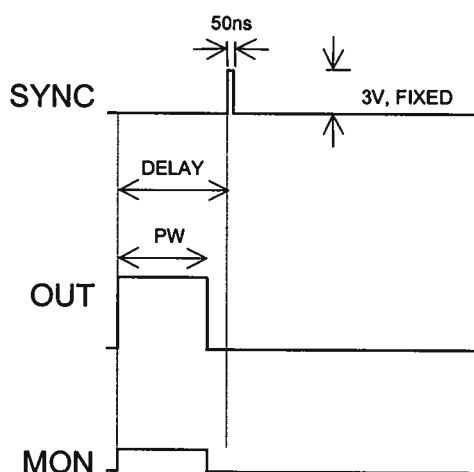

Basic Output Pulses for Delay < 0

The delay, pulse width, amplitude and frequency of the OUT pulse can be varied with front panel controls or via the GPIB or RS-232 computer interfaces in this mode.

External Triggering, with Normal PW and Amplitude Modes

When the triggering is set to external mode, and the pulse width and amplitude modes are set to "normal" (i.e., the front-panel display reads "EXT TRIG", "PW:??ns", and "AMP:??mA", where "??" means a number), a TTL-level pulse on the TRIG input will trigger the pulse generator, as shown below:

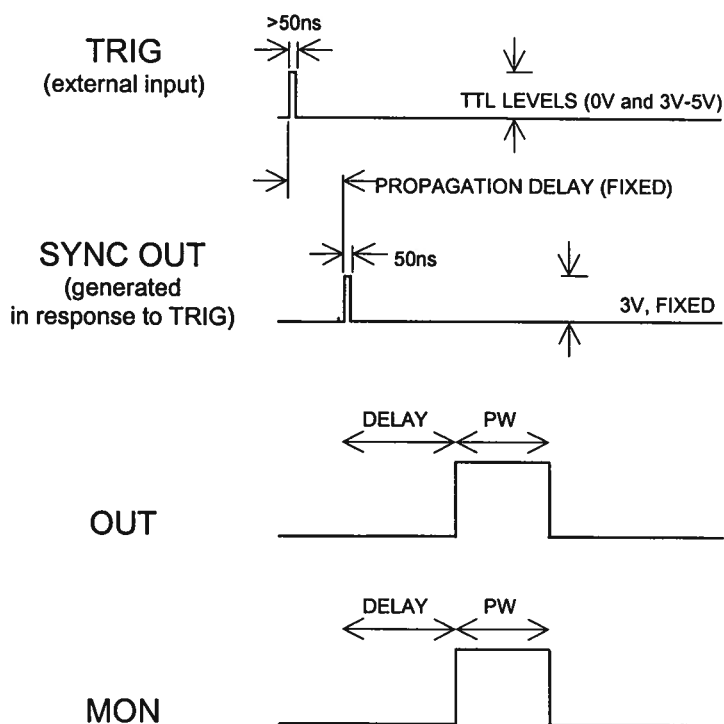

In this mode, the delay, pulse width, and amplitude of the OUT pulse can be varied with front panel controls or via the GPIB or RS-232 computer interfaces.

External Triggering, with $PW_{IN}=PW_{OUT}$ mode and Normal Amplitude Mode

When the triggering is set to external mode, the amplitude mode is set to "normal", and the " $PW_{IN}=PW_{OUT}$ " pulse width mode is used, (i.e., the front-panel display reads "EXT TRIG", "PW IN=OUT", and "AMP:??mA", where "??" is a number) a TTL-level pulse on the TRIG input will trigger the pulse generator, as shown below:

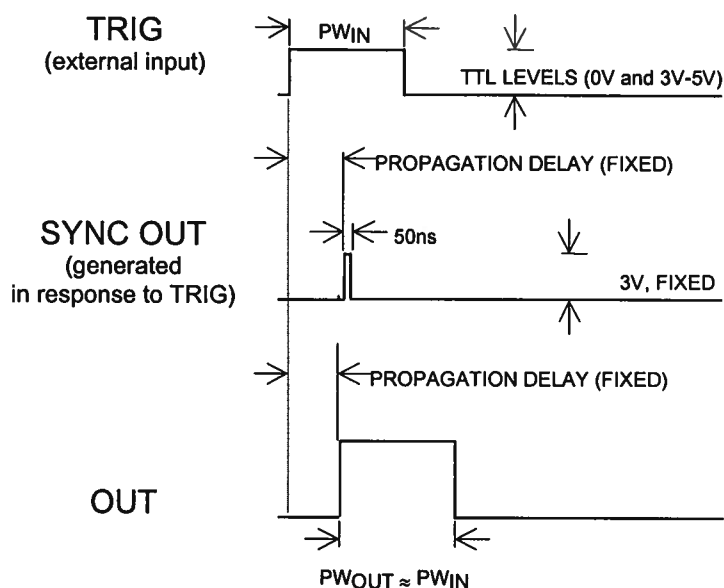

In this mode, the output pulse width is approximately equal to the pulse width of the TTL-level trigger pulse on the TRIG input. The output pulse is generated after a short propagation delay. The delay is not variable. The amplitude of the OUT pulse can be varied with front panel controls or via the GPIB or RS-232 computer interfaces.

External Amplitude Mode

For instruments with the "-EA" option:

In any of the previously mentioned modes, the amplitude can be set to track a 0 to +10V DC voltage present on the AMP connector. (In this mode, the front-panel display reads "AMP:EXT".) This is illustrated below:

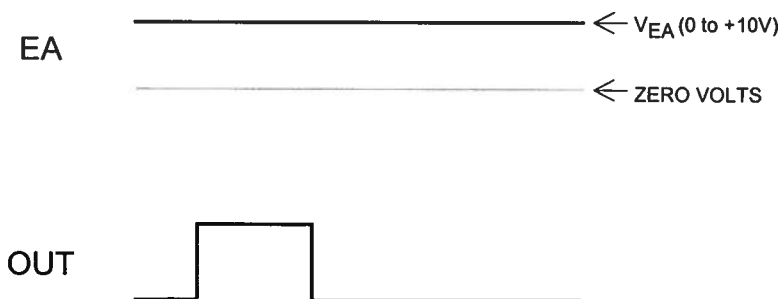

The pulse width, delay, frequency, and triggering are controlled as described above.

For -PN units, the output polarity remains at its last setting before the amplitude is switched to the external amplitude mode.

Amplifier Mode (Voltage-to-Current Converter)

When the triggering is set to amplifier mode (i.e., the front-panel display reads “EXT AMPLIFY”), the instrument acts as a fixed-gain voltage-to-current amplifier, and the output current is: $I_{OUT} \approx V_{AMP} \times 200 \text{ mA/V}$, where V_{AMP} is the voltage waveform on the AMP connector. This is illustrated below:

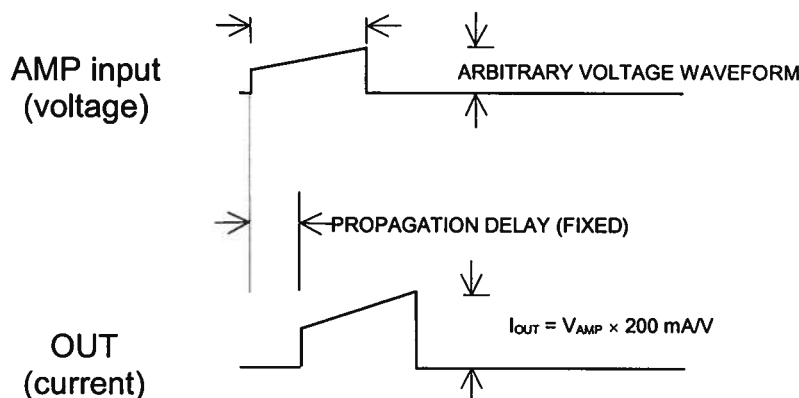

For -PN units, the output polarity remains at its last setting before the amplitude is switched to the amplify mode.

In this mode, the output pulse width and amplitude are determined by the signal on the AMP connector. The SYNC output is not useful in this mode.

TRIGGER MODES

This instrument has four front-panel trigger modes:

- Internal Trigger: the instrument controls the trigger frequency, and generates the clock internally.

- External Trigger: the instrument is triggered by an external TTL-level clock on the back-panel TRIG connector.
- Manual Trigger: the instrument is triggered by the front-panel "SINGLE PULSE" pushbutton.
- Hold Trigger: the instrument is set to not trigger at all.

These modes can be selected using the front panel trigger menu, or by using the appropriate programming commands. (See the "Source:Trigger" section of the "OP1B Interface Programming Manual" for more details.)

When being controlled by a computer, there is a fifth trigger mode:

- Immediate Trigger: generates a single trigger event. This is the computer-control equivalent of pressing the front-panel "SINGLE PULSE" pushbutton.

GATING MODES

Triggering can be suppressed by a TTL-level signal on the rear-panel GATE connector. The instrument can be set to stop triggering when this input high or low, using the front-panel gate menu or the appropriate programming commands. This input can also be set to act synchronously or asynchronously. When set to asynchronous mode, the GATE will disable the output immediately. Output pulses may be truncated. When set to synchronous mode, the output will complete the full pulse width if the output is high, and then stop triggering. No pulses are truncated in this mode.

CONNECTING THE LOAD FOR OPTIMUM PERFORMANCE

USING THE SUPPLIED CABLES

This instrument is supplied with two types of output cables, which can be plugged in the the OUT socket on the rear panel:

- The LZ1 flexible flat transmission line, which has a 1Ω characteristic impedance (Z_0), and is terminated with a small circuit board.
- A 6" RG174 coaxial transmission line, which has a 50Ω characteristic impedance (Z_0). A connectorized 2 Ohm test load, which connects to this cable, is supplied with the instrument. Note that the waveform may become distorted if this cable is extended to longer lengths.

For both cables, the end that plugs into the rear panel is marked with an "UP" side and a "DOWN" side. (The UP side is the signal output, and the DOWN side is ground.)

The end of the LZ1 line is illustrated below:

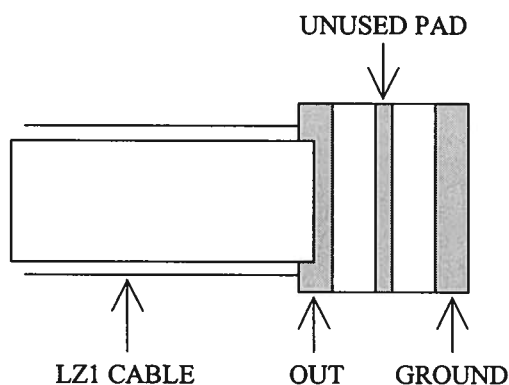

To connect a diode load, it should be soldered between the OUT and GROUND pads, as shown schematically below:

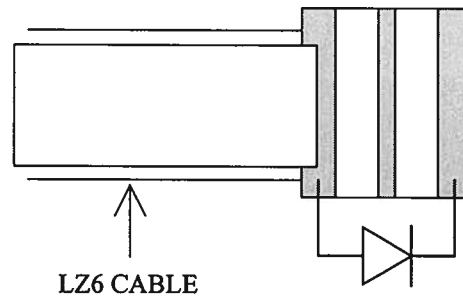

In the above illustration, the diode is oriented for positive current flow. It should be reverse for negative current.

ADDING A SERIES RESISTANCE

If your load has a very low impedance, or if the impedance is lower than the characteristic impedance of the connecting cable, the current waveform may show some ringing. This can often be reduced by adding a low-inductance resistance in series with the load. (Keep all lead lengths to a minimum to minimize inductive effects).

Some experimentation may be required to determine the optimum resistance. (Note that the resistance must be kept low enough that the compliance voltage is not exceeded.)

LOAD AND INSTRUMENT PROTECTION

PROTECTING DIODE LOADS

It is possible for a small offset current to be generated on the output, if the trimpots (see the "Calibration Adjustments" section) are not correctly adjusted. This can lead to the development of a negative voltage on a diode load. If the diode breakdown voltage is less than 15V, breakdown can occur. If your load is sensitive to this, the load should be protected by adding a low capacitance shunt diode, as illustrated below:

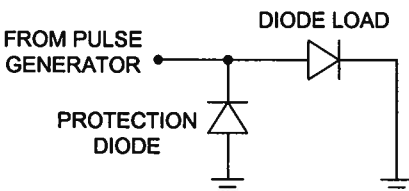

(This assumes that the diode is to be driven with a positive current.) This circuit will prevent the output voltage going below approximately -0.7V.

LENZ'S LAW AND INDUCTIVE VOLTAGE SPIKES

This instrument is designed to pulse resistive and diode loads and will exhibit a large output spike when used to drive a load with significant inductance (as predicted by LENZ'S LAW). For this reason the load should be connected to the output using low inductance leads (as short as possible and as heavy a gauge as possible).

The voltage developed across an inductance L (in Henries), when the current is changing at a rate given by di_{LOAD}/dt (in Amps/sec), is: $V_{SPIKE} = L \frac{di_{LOAD}}{dt}$.

OUTPUT ON/OFF

The main outputs may be switched on and off using the front-panel controls or via programming commands. When the output is set "OFF", the main outputs are short-circuited to ground with a relay, and the trigger source is removed from the output stage.

ATTACHING AND DETACHING LOADS

To avoid damaging the loads connected to main outputs, the loads should only be connected to or removed from the instrument when:

- the instrument is off
- the instrument is on, but the outputs are turned off (i.e. the LCD display reads "OUTPUT OFF")

Do not connect loads when the instrument is on and the outputs are turned on. This can cause mild sparking.

CHANGING PARAMETERS WHEN A LOAD IS ATTACHED

If your load is easily damaged, the outputs should be turned off when changing the trigger source, frequency, pulse width, or other pulse parameters. This protects the loads from possible short transient effects.

OPEN AND SHORT CIRCUITS

The AV-155B-B will operate properly into a short circuit to ground.

Operation into an open circuit will not damage the instrument in any way, although the monitor circuit may not give the correct reading (which should be zero).

AVOID EXCESS POWER DISSIPATION

To prolong the life of the output stages of the instrument, the internal power dissipation should be minimized whenever practical. The power dissipated in each of the two output stages can be calculated using:

$$P_{DISS} = (15V - V_{LOAD}) \times I_{PEAK} \times \text{Duty Cycle}$$

To minimize power dissipation, keep the current amplitude and duty cycle as low as practical. Operation into larger load resistance is preferred over operation into a low load resistance, since $V_{LOAD} = I_{PEAK} \times R_{LOAD}$.

OPERATIONAL CHECK

This section describes a sequence to confirm the basic operation of the instrument. It should be performed after receiving the instrument. It is a useful learning exercise as well.

Before proceeding with this procedure, finish reading this instruction manual thoroughly. Then read the "Local Control" section of the "OP1B Interface Programming Manual" thoroughly. The "Local Control" section describes the front panel controls used in this operational check - in particular, the MOVE, CHANGE, and ADJUST controls.

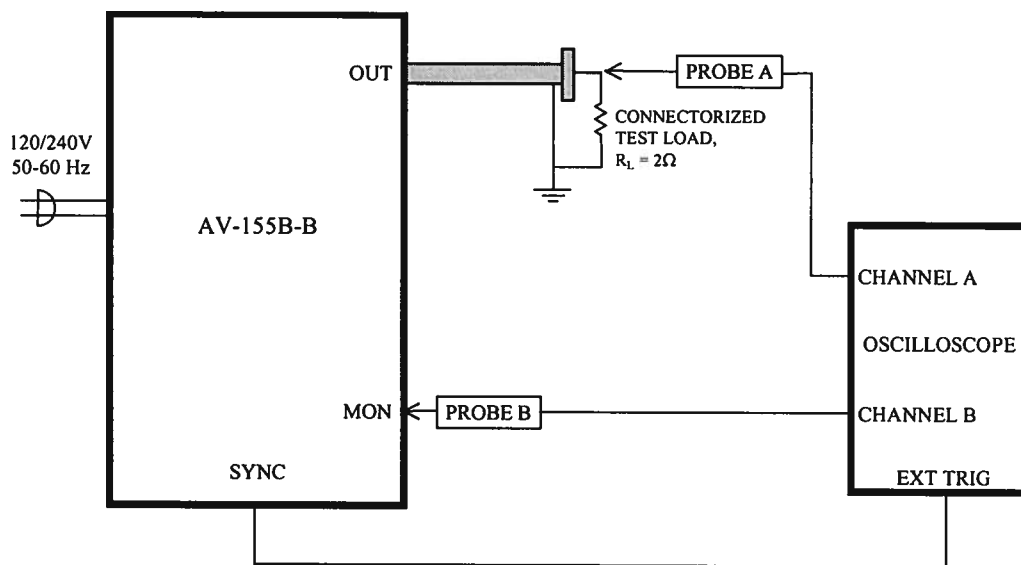

Basic Test Arrangement

- 1) Connect the supplied low-inductance 2 Ohm test load to the RG174 cable. Insert the card edge of the cable into the OUT connector.
- 2) Connect a cable from the SYNC OUT connector to the TRIG input of an oscilloscope. Set the oscilloscope to trigger externally.
- 3) Connect one oscilloscope probe (channel A) to the OUT1 load. Connect the other probe to the MON1 output (on the rear panel). On the oscilloscope, set the channel A vertical scale to 1 V/div, the channel B vertical scale to 1 V/div, and the horizontal scale to 1 μ s/div.
- 4) Turn on the AV-155B-B. The main menu will appear on the LCD.
- 5) To set the AV-155B-B to trigger from the internal clock at a PRF of 10 kHz:

- The arrow pointer should be pointing at the frequency menu item. If it is not, press the MOVE button until it is.
 - Press the CHANGE button. The frequency submenu will appear. Rotate the ADJUST knob until the frequency is set at 10 kHz.
 - The arrow pointer should be pointing at the "Internal" choice. If it is not, press MOVE until it is.
 - Press CHANGE to return to the main menu.
- 6) To set the delay to 1 μ s:
- Press the MOVE button until the arrow pointer is pointing at the delay menu item.
 - Press the CHANGE button. The delay submenu will appear. Rotate the ADJUST knob until the delay is set at 1 μ s.
 - Press CHANGE to return to the main menu.
- 7) To set the pulse width to 1.5 μ s:
- Press the MOVE button until the arrow pointer is pointing at the "PW" menu item.
 - Press the CHANGE button. The pulse width submenu will appear. Rotate the ADJUST knob until the pulse width is set at 1.5 μ s.
 - The arrow pointer should be pointing at the "Normal" choice. If it is not, press MOVE until it is.
 - Press CHANGE to return to the main menu.
- 8) At this point, nothing should appear on the oscilloscope.
- 9) To enable the output:
- Press the MOVE button until the arrow pointer is pointing at the output menu item.
 - Press the CHANGE button. The output submenu will appear.
 - Press MOVE until the arrow pointer is pointing at the "ON" choice.
 - Press CHANGE to return to the main menu.

10) To change the output amplitude:

- Press the MOVE button until the arrow pointer is pointing at the AMP menu item.
- Press the CHANGE button. The amplitude submenu will appear. Rotate the ADJUST knob until the amplitude is set at 800 mA.
- Observe the oscilloscope. You should see 1.5 μ s wide, 1.6 V pulses (i.e., $800 \text{ mA} \times 2 \Omega = 1.6\text{V}$) on the probe connected to the OUT1 main output. The other probe, connected to the MON monitor output, should also show 1.5 μ s, .8V pulses (i.e. $800 \text{ mA} \times 1 \text{ V/A}$).
- Press CHANGE to return to the main menu.

11) Try varying the pulse width, by repeating step (7). As you rotate the ADJUST knob, the pulse width on the oscilloscope will change.

12) This completes the operational check.

If additional assistance is required:

Tel: (613) 226-5772, Fax: (613) 226-2802
Email: info@avtechpulse.com

CALIBRATION ADJUSTMENTS - INTERNAL TRIMPOTS

The output module has five trimming potentiometers ("trimpots") that can be used to adjust the performance of the output. These trimpots are preset at the factory and should not normally require adjusting after delivery. These controls can be accessed by removing the top panel of the instrument, and by locating the output-stage module. It is near the rear of the instrument.

The locations of the trimpots (designated TP1-TP5) are shown below. All should be accessible through any heatsinking.

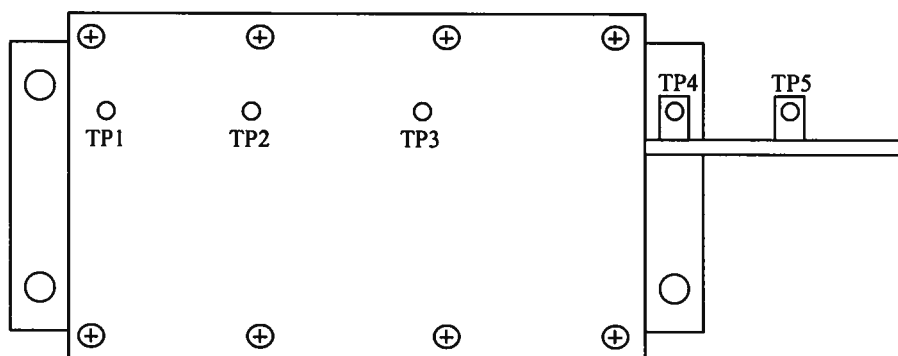

Location of Trimpots

These trimpots can be used to adjust or calibrate the followings properties:

- Current offsets on the main outputs.
- Voltage offsets on the monitor outputs.
- Monitor calibration.
- Output impedance.

NULLING CONSTANT CURRENT OFFSETS

If a small constant current offset is observed on one of the main outputs, TP2 can be rotated to reduce it to zero. Note that the output stage is incapable of generating a negative current, due to the presence of a diode in series with the output.

NULLING AMPLITUDE-DEPENDENT CURRENT OFFSETS

If a small amplitude-dependent current offset is observed on one of the main outputs, TP1 can be rotated to null it out. Rotate TP1 while adjusting the output amplitude from the front panel, until the offset does not vary with amplitude.

NULLING CONSTANT MONITOR OFFSETS

If a small constant voltage offset is observed on one of the monitor outputs, TP5 can be rotated to reduce it to zero.

ADJUSTING OUTPUT IMPEDANCE

Ideally, the outputs of the pulsed current sources should be independent of the output voltages, within the 0 to $\pm 4\text{V}$ compliance voltage range. This condition represents infinite output impedance. If a load voltage/output current dependence is present, the output impedance needs to be adjusted.

To adjust the output impedance, connect a 2Ω load to the output to be adjusted. Set the output amplitude to 0.8A and observe the load voltage on an oscilloscope. The load voltage should have an amplitude of approximately 1.6V (i.e. $0.8\text{A} \times 2\Omega = 1.6\text{V}$). Note the exact value. Now replace the 2Ω load with a 1Ω load. The load voltage should fall by to approximately 0.8V (i.e. $0.8\text{A} \times 1\Omega = 0.8\text{V}$). Note the exact value. If the second voltage is not exactly one-half of the first voltage, adjust TP3 and repeat *both* measurements (2Ω and 1Ω) again. Repeat as required.

ADJUSTING MONITOR CALIBRATION

Just as the current amplitude of the main outputs can exhibit a load-voltage dependence, the voltage amplitude of the current monitors can also exhibit such a dependence if not adjusted properly.

To null out the monitor load voltage dependence, connect a 2Ω load to the main output. Set the output amplitude to 0.8A and observe the monitor voltage on an oscilloscope. The monitor voltage should have an amplitude of approximately 1.6V . Note the exact value. Now replace the 2Ω load with a 1Ω load. The monitor voltage should not change, since the current amplitude has not changed. Note the exact value. If the second voltage is not exactly equal to the first voltage, adjust TP4 and repeat *both* measurements (2Ω and 1Ω) again. Repeat as required.

CALIBRATION ADJUSTMENTS - SOFTWARE PROCEDURES

ADJUSTING AMPLITUDE ACCURACY

If it is found that the output amplitude setting (as set by the front-panel controls or programming commands) does not agree exactly with measured values of amplitude (i.e., by examining the output on an oscilloscope), the amplitude calibration can be updated using software commands.

The following procedure is suggested:

- 1) Connect a precision resistive load to the output. (As an example, suppose 10Ω is used.)
- 2) Connect the pulse generator to a computer using the GPIB or RS232 ports.
- 3) Turn on the pulse generator, and set the time controls (frequency, delay, pulse width) to typical values.
- 4) Turn on the outputs.
- 5) Set the output amplitude to its maximum value (0.8A).
- 6) Observe the voltage across the load. (Continuing the 2Ω example, suppose that 1.7V is observed.) From this, calculate the measured current (0.85A).
- 7) Send one of the following commands to the instrument via the computer interface:
 - `diag:ampl:cal 0.85A`

The internal software compares the supplied measured value to the programmed value, and adjusts the internal calibration data to null out any differences.

- 8) Observe the voltage across the load again. The amplitude setting should now agree with the measured value.

The same procedure can be performed for the offset function, except that the "diag:offset:cal" command is used.

MECHANICAL INFORMATION

TOP COVER REMOVAL

The top cover of the instrument may be removed by removing the four Phillips screws on the top panel. With these four screws removed, the top panel may be slid off by pulling it towards the rear.

The instrument should not be accessed internally unless it has been turned off for ten minutes, to allow all internal capacitors to discharge. The internal capacitor bank stores a considerable amount of energy.

RACK MOUNTING

A rack mounting kit is available. The -R5 rack mount kit may be installed after first removing the one Phillips screw on the side panel adjacent to the front handle.

PROGRAMMING YOUR PULSE GENERATOR

KEY PROGRAMMING COMMANDS

The "OP1B Interface Programming Manual" describes in detail how to connect the pulse generator to your computer, and the programming commands themselves. A large number of commands are available; however, normally you will only need a few of these. Here is a basic sample sequence of commands that might be sent to the instrument after power-up, using the internal trigger source:

```
*rst                (resets the instrument)
trigger:source internal (selects internal triggering)
frequency 1 kHz      (sets the frequency to 1 kHz)
pulse:width 100 ns   (sets the pulse width to 100 ns)
pulse:delay 200 ns   (sets the delay to 200 ns)
output on            (turns on the output)
source:current 100 mA (sets the amplitude to 0.1 amperes)
source:current:low 100 mA (sets the offset to 100 mA)
```

For triggering a single event, this sequence would be more appropriate:

```
*rst                (resets the instrument)
trigger:source hold   (turns off all triggering)
pulse:width 100 ns    (sets the pulse width to 100 ns)
output on            (turns on the output)
source:current 100 mA (sets the amplitude to 0.1 amperes)
source:current:low 100 mA (sets the offset to 100 mA)
trigger:source immediate (generates a single non-repetitive trigger event)
trigger:source hold   (turns off all triggering)
output off           (turns off the output)
```

To set the output pulse width to track the trigger pulse width in external mode, use:

```
*rst                (resets the instrument)
trigger:source external (selects external triggering)
pulse:width in        (PWOUT = PWIN)
output on            (turns on the output)
source:current 100 mA (sets the amplitude to 0.1 amperes)
source:current:low 100 mA (sets the offset to 100 mA)
```

To set the instrument to work as an amplifier (i.e., $I_{OUT} = V_{AMP} \times 200 \text{ mA/V}$), use:

```
*rst                (resets the instrument)
output on          (turns on the output)
```

source:current amplify (switches to amplifier mode)

These commands will satisfy 90% of your programming needs.

ALL PROGRAMMING COMMANDS

For more advanced programmers, a complete list of the available commands is given below. These commands are described in detail in the "OP1B Interface Programming Manual". (Note: this manual also includes some commands that are not implemented in this instrument. They can be ignored.)

<u>Keyword</u>	<u>Parameter</u>	<u>Notes</u>
DIAGnostic:		
:AMPLitude		
:CALibration	<numeric value>	[no query form]
:OFFSet		
:CALibration	<numeric value>	[no query form]
LOCAL		
OUTPut:		
:[STATe]	<boolean value>	
:PROTection		
:TRIPped?		[query only]
REMOTE		
[SOURce]:		
:FREQuency		
[:CW FIXed]	<numeric value>	
[SOURce]:		
:CURRent		
[:LEVel]		
[:IMMediate]		
[:AMPLitude]	<numeric value> AMPLify EXTernal	
:LOW	<numeric value>	
:PROTection		
:TRIPped?		[query only]
[SOURce]:		
:PULSe		
:PERiod	<numeric value>	
:WIDTh	<numeric value> IN	
:DCYClE	<numeric value>	
:HOLD	WIDTh DCYClE	
:DELay	<numeric value>	
:GATE		
:TYPE	ASYNc SYNc	
:LEVel	High Low	
STATUS:		
:OPERation		
:[EVENT]?		[query only, always returns "0"]
:CONDition?		[query only, always returns "0"]
:ENABle	<numeric value>	[implemented but not useful]
:QUESTionable		
:[EVENT]?		[query only, always returns "0"]
:CONDition?		[query only, always returns "0"]
:ENABle	<numeric value>	[implemented but not useful]

SYSTem:		
:COMMunicate		
:GPIB		
:ADDRESS	<numeric value>	
:SERial		
:CONTRol		
:RTS	ON IBFull RFR	
:[RECeive]		
:BAUD	1200 2400 4800 9600	
:BITS	7 8	
:ECHO	<boolean value>	
:PARity		
:[TYPE]	EVEN ODD NONE	
:SBITS	1 2	
:ERRor		
:[NEXT]?		[query only]
:COUNT?		[query only]
:VERSion?		[query only]
TRIGger:		
:SOURce	INTernal EXTernal MANual HOLD IMMEDIATE	
*CLS		[no query form]
*ESE	<numeric value>	
*ESR?		[query only]
*IDN?		[query only]
*OPC		
*SAV	0 1 2 3	[no query form]
*RCL	0 1 2 3	[no query form]
*RST		[no query form]
*SRE	<numeric value>	
*STB?		[query only]
*TST?		[query only]
*WAI		[no query form]

PERFORMANCE CHECK SHEET