



AVTECH ELECTROSYSTEMS LTD.

NANOSECOND WAVEFORM ELECTRONICS
SINCE 1975

P.O. BOX 265
OGDENSBURG, NY
U.S.A. 13669-0265
TEL: (315) 472-5270
FAX: (613) 226-2802

TEL: 1-800-265-6681
FAX: 1-800-561-1970
U.S.A. & CANADA

e-mail: info@avtechpulse.com

BOX 5120 STN. F
OTTAWA, ONTARIO
CANADA K2C 3H4
TEL: (613) 226-5772
FAX: (613) 226-2802

INSTRUCTIONS

MODEL AV-155B-C-EA-AT4-M-OP2 PULSE GENERATOR

S.N. :

WARRANTY

Avtech Electrosystems Ltd. warrants products of its manufacture to be free from defects in material and workmanship under conditions of normal use. If, within one year after delivery to the original owner, and after prepaid return by the original owner, this Avtech product is found to be defective, Avtech shall at its option repair or replace said defective item. This warranty does not apply to units which have been disassembled, modified or subjected to conditions exceeding the applicable specifications or ratings. This warranty is the extent of the obligation or liability assumed by Avtech with respect to this product and no other warranty or guarantee is either expressed or implied.



AVTECH ELECTROSYSTEMS LTD.

NANOSECOND WAVEFORM ELECTRONICS
SINCE 1975

□ P.O. BOX 265
OGDENSBURG, NY
U.S.A. 13669-0265
TEL: (315) 472-5270
FAX: (613) 226-2802

TEL: 1-800-265-6681
FAX: 1-800-561-1970
U.S.A. & CANADA

e-mail: info@avtechpulse.com

□ BOX 5120 STN. F
OTTAWA, ONTARIO
CANADA K2C 3H4
TEL: (613) 226-5772
FAX: (613) 226-2802

CAUTION

To avoid possible damage to the laser diode, the following start up and shut down sequences should be followed:

START UP SEQUENCE

- 1) POWER switch is OFF (i.e. button out).
- 2) Set amplitude controls fully CCW.
- 3) Set OPERATE-STANDBY switch to STANDBY position.
- 4) Connect the laser diode to the output connector.
- 5) Apply prime power by setting the POWER switch in the ON position (i.e. push button in).
- 6) Set OPERATE-STANDBY switch to OPERATE position.
- 7) Set amplitude to desired level. Do not change the position of the OPERATE-STANDBY switch from OPERATE to STANDBY without first setting the amplitude controls to fully CCW.

SHUT DOWN SEQUENCE

- 1) Set amplitude controls fully CCW.
- 2) Set OPERATE-STANDBY switch to the STANDBY position.
- 3) Turn off the prime power by pushing the POWER switch button.
- 4) Remove the laser diode from the OUT connector.

Fig. 1

MODEL AV-155B-C PULSE GENERATOR TEST ARRANGEMENT

(RESISTIVE LOAD, NO DIODE)

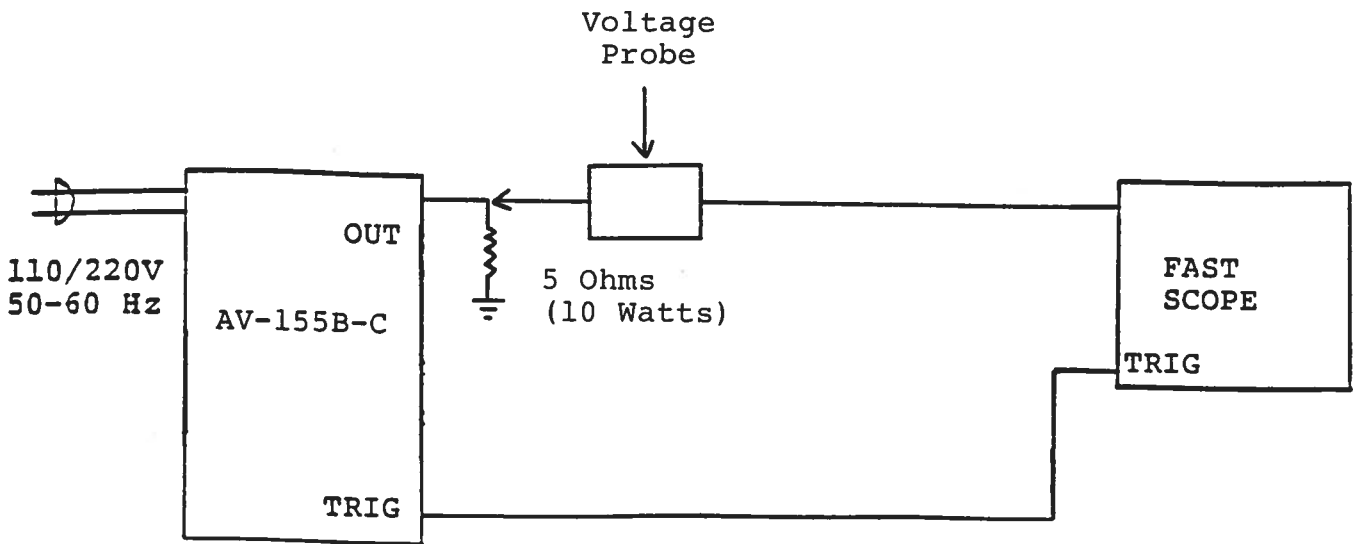

Notes:

- 1) For front panel manual control of the output parameters the rear panel LOCAL-REMOTE switch must be in the LOCAL position. For remote control using the PINNACLE INSTRUMENTS PC-1 controller, the switch should be in the REMOTE position. See the PC-1 instruction manual for this mode of operation.
- 2) The bandwidth capability of components and instruments used to display the pulse generator output signal (probes, cables, connectors, etc.) should exceed 100 MHz.
- 3) A low-inductance resistor should be used as the test load. Note that an inductance of 50 nh will yield an inductance spike of about one Volt.
- 4) To control the unit via the internal clock, set the INT-EXTA-EXTB switch in the INT position. Set the PRF range switch in either the 2 kHz or 20 kHz position.
- 5) The output pulse width is controlled by means of the front panel one turn PW control and the three position range switch. The control should initially be set mid range and the pulse width adjusted using an oscilloscope.
- 6) The output pulse amplitude is controlled by means of the front panel one turn AMP control and the two position range switch. Note that the load voltage range (i.e. compliance voltage) of the unit is 9 Volts so the load resistance must be sufficiently low (ideally 5 Ohms) so that the load voltage does not exceed 9 Volts.
- 7) The amplitude range switch function (0.25 or 1.0 Amp) may be controlled electronically by placing the rear panel RANGE switch in the EXT position and applying 0V (250 mA) or +5V (1.0 Amp) to the BNC terminal.
- 8) The output pulse amplitude may be controlled electronically by placing the rear panel AMP switch in the EXT position and by applying 0 to +10 VDC to the BNC connector.
- 9) The output DC bias is controlled by the front panel DC bias ten turn control and the ON-OFF switch. The range of the bias is always the same as the output pulse range.

- 10) The DELAY control controls the relative delay between the reference output pulse provided at the TRIG output and the main output. This delay is variable over the range of 10 us to 10 ms. The TRIG output precedes the main output when the ADVANCE-DELAY switch is in the ADVANCE position and lags when the switch is in the DELAY position.
- 11A) The unit may also be triggered externally by setting the INT-EXTA-EXTB switch in either the EXTA or EXTB position and applying a trigger pulse at the TRIG BNC.
- 11B) When the switch is in the A position the unit operates as a voltage to current converter as follows:

$$I_{OUT} = 0.25 V_{IN}$$

Note that in this mode, the input amplitude should not exceed +4 Volts and also note that the PRF pulse width, amplitude and DC bias controls on the front panel are inactive.

- 11C) When the switch is in the B position, the unit requires a TTL input trigger pulse (PW > 50 ns) and the output pulse width, amplitude and DC bias are controlled by the front panel controls. The input trigger rate should not exceed 20 kHz as this may result in damage to the unit.
- 12) The unit can be converted from 100 to 220V 50-60 Hz operation by adjusting the voltage selector card in the rear panel fused voltage selector-cable connector assembly.
- 13) For additional assistance:

Tel: (613) 226-5772
Fax: (613) 226-2802

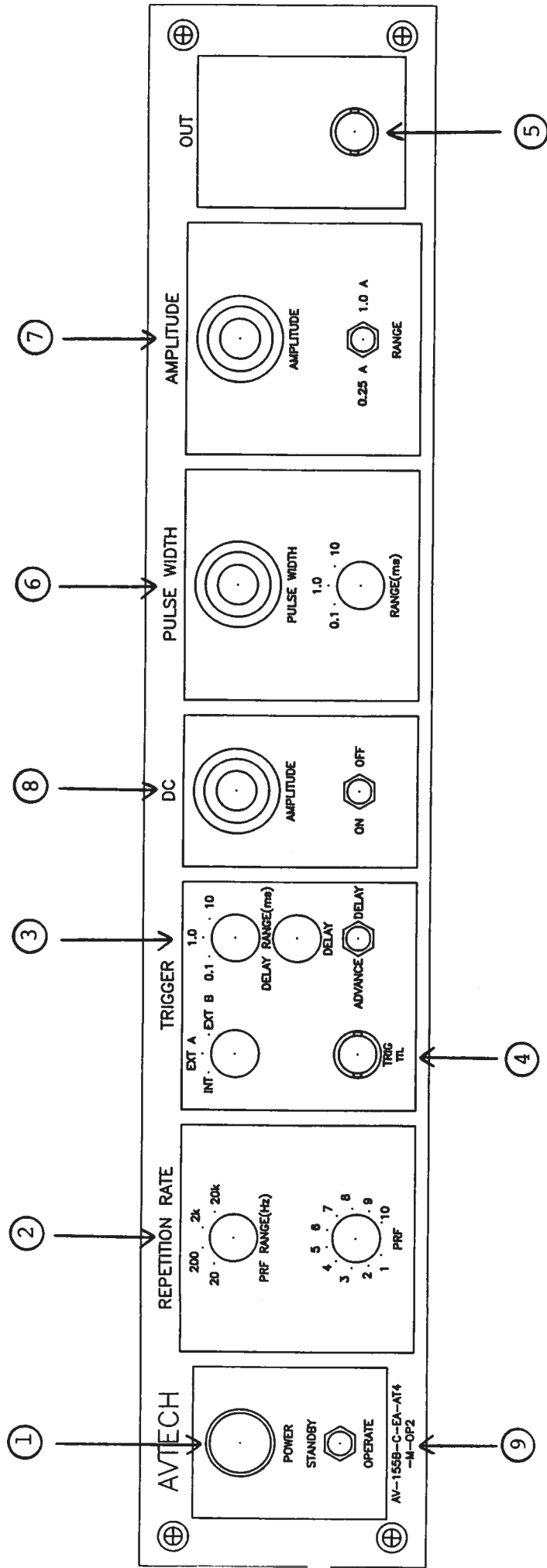

Fig. 2 FRONT PANEL CONTROLS

- (1) ON-OFF Switch. Applies basic prime power to all stages.
- (2) PRF Control. Varies PRF from 2 Hz to 20 kHz as follows:
 - 2 Hz to 20 Hz
 - 20 Hz to 200 Hz
 - 200 Hz to 2 kHz
 - 2 kHz to 20 kHz
- (3) DELAY Control. Controls the relative delay between the reference output pulse provided at the TRIG output (4) and the main output (5). This delay is variable over the range of 10 us to about 10 ms. Delay LEADS or LAGS depending on the position of the ADVANCE-DELAY switch.
- (4) TRIG. When the INT-EXTA-EXTB switch is in the INT position this output is used to trigger the scope time base. The output is a TTL level 100 ns (approx.) pulse capable of driving a fifty Ohm load. This output precedes the output at (5) if the two position ADVANCE-DELAY switch is in the ADVANCE position. This output follows the output at (5) if the switch is in the DELAY position. The delay range is variable from 10 us to 10 ms. The external trigger signal is applied at this input when the toggle switch is in the EXTA or EXTB position. When the switch is in the A position the unit operates as a voltage to current converter as follows:

$$I_{OUT} = 0.25 V_{IN}$$

Note that in this mode, the input amplitude should not exceed +4 Volts and also note that the PRF, pulse width, amplitude and DC bias controls on the front panel are inactive.

When the switch is in the B position, the unit requires a TTL input trigger pulse (PW > 50 ns) and the output pulse width, amplitude and DC bias are controlled by the front panel controls. The input trigger rate should not exceed 20 kHz as this may result in damage to the unit.

- (5) OUT. Diode load connects to this BNC connector (anode to the center conductor and cathode to ground).

- (6) PULSE WIDTH. Varies output pulse width as follows (INT and EXT B MODE only):

10 us to 100 us
100 us to 1 ms
1 ms to 10 ms

- (7) PULSE AMPLITUDE. Ten turn amplitude control and two position range switch vary output pulse amplitude from 0 to 250 mA or 0 to 1.0 Amp (INT and EXT B mode only).
- (8) DC BIAS AMPLITUDE. Ten turn offset control and the AMPLITUDE RANGE switch (7) vary the DC offset from 0 to 250 mA or 0 to 1.0 Amp (INT and EXT B mode only). Two position ON-OFF switch controls DC function. Pulse output disabled when DC is ON.
- (9) STANDBY-OPERATE. When this switch is in the STANDBY position, a set of relay controls shorts out the laser diode whether the prime power is ON or OFF. When the switch is in the OPERATE position, the relay contacts open, provided the prime power is on. See the START UP and SHUT DOWN SEQUENCE notes preceding Fig. 1 for a full discussion of the operation of this switch.

BACK PANEL CONTROLS

- 1) Power Entry Module. Detachable line cord connects to this point. Also contains voltage selector card and line fuse (0.50 A SB).
- 2) 1.0 A SB Fuse. Limits current supplied to the output stage.
- 3) Monitor Option. BNC connector provides a coincident replica of the output pulse. For $R_L \geq 1K$.

$$I_{LOAD} = V_M \text{ (Volts, Amp)}$$

$$\text{For } R_L = 50 \text{ Ohm,}$$

$$I_{LOAD} = 2 V_M \text{ (Volts, Amp)}$$

V_M is the monitor output voltage, amplitude is determined using a scope.

- 4) Cover Screws. To remove the top cover, remove the 4 Phillips screws and the top cover may then be slid back and off.
- 5) LOCAL REMOTE SWITCH. This two-position switch must be in the LOCAL position to operate the instrument from the front panel controls. To control the instrument using the PINNACLE INSTRUMENTS Model PC-1, the switch must be in the REMOTE position.
- 6) OP2 CONNECTOR. 36 conductor CENTRONICS CAT. NO. 45-4395 cable (supplied) connects between this connector and the PINNACLE INSTRUMENTS Model PC-1.
- 7) RANGE. For remote control of amplitude range (pulse or DC) set the two-position switch in the EXT position and apply to the BNC connector, 0 Volts for 250 mA or +5 Volts for 1.0 Ampere (TTL control).
- 8) AMP. For remote control of pulse amplitude, set the two-position switch in the EXT position and apply 0 to +10 VDC ($R_{IN} > 10K$) to the BNC connector.

Fig. 3

BACK PANEL CONTROLS

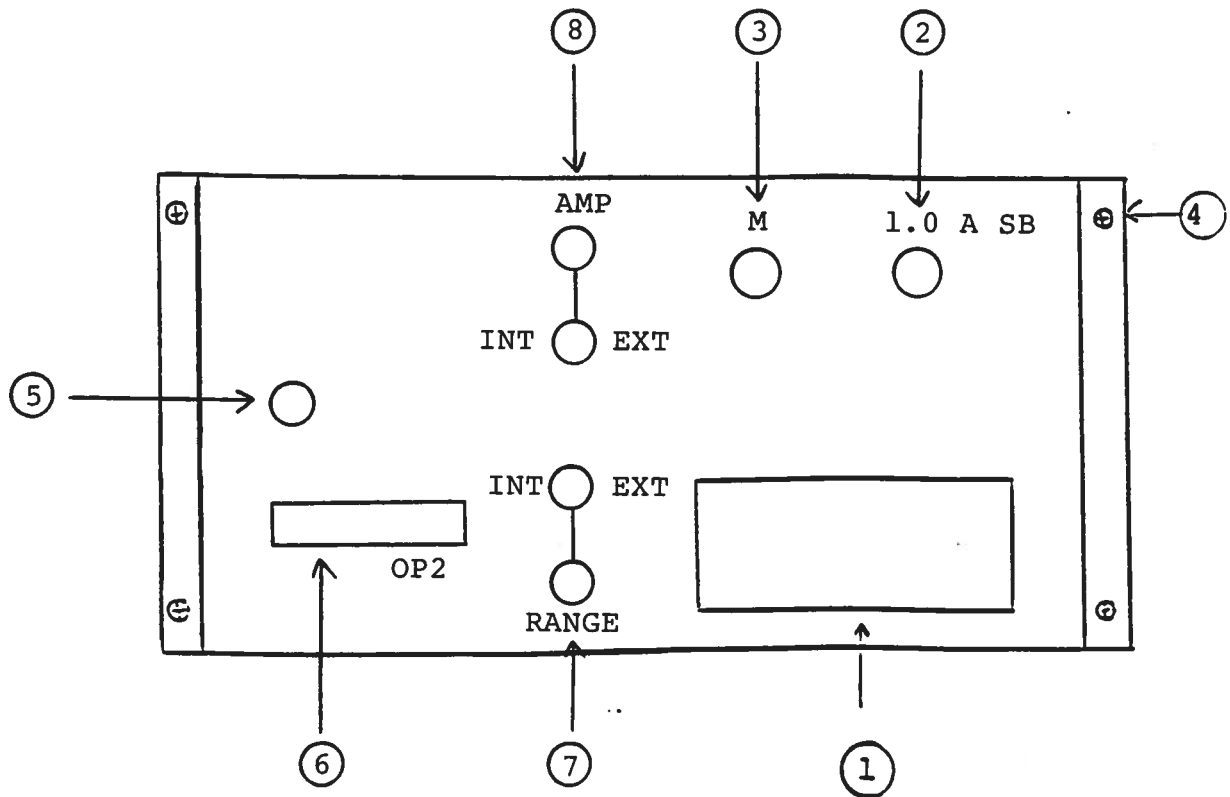

April 26/95

Disk: AV-

Name: 55BCEAT4.INS